

MB100 Slabmizer
Safety, Setup, Operation,
Maintenance, & Parts Manual

MB100

rev. A1.00

Safety is our #1 concern!

Form #2483



WARNING! Read and understand this manual before using this machine.

California

Proposition 65 Warning



WARNING: Breathing gas/diesel engine exhaust exposes you to chemicals known to the State of California to cause cancer and birth defects or other reproductive harm.

Always start and operate the engine in a well-ventilated area.
If in an enclosed area, vent the exhaust to the outside.
Do not modify or tamper with the exhaust system.
Do not idle the engine except as necessary.

For more information go to www.P65warnings.ca.gov.



WARNING: Drilling, sawing, sanding or machining wood products can expose you to wood dust, a substance known to the State of California to cause cancer. Avoid inhaling wood dust or use a dust mask or other safeguards for personal protection.

For more information go to www.P65Warnings.ca.gov/wood.

Active Patents assigned to Wood-Mizer, LLC

Wood-Mizer, LLC has received patents that protect our inventions which are a result of a dedication to research, innovation, development, and design. Learn more at: woodmizer.com/patents

©March 20, 2024 Wood-Mizer LLC

Printed in the United States of America, all rights reserved. No part of this manual may be reproduced in any form by any photographic, electronic, mechanical or other means or used in any information storage and retrieval system without written permission from

Wood-Mizer, LLC
8180 West 10th Street
Indianapolis, Indiana 46214

SECTION 1 INTRODUCTION

1.1 About This Manual 1-1
 1.2 Getting Service..... 1-1
 1.3 Specifications 1-1
 1.4 Options and Accessories 1-1

SECTION 2 GENERAL SAFETY

2.1 Safety Symbols 2-1
 2.2 Safety Instructions..... 2-1
 2.3 Electrical Lockout Procedures 2-2
 2.4 Safety Labels Description 2-4

SECTION 3 SLAB FLATTENER SETUP

3.1 Uncrate and Prepare Parts 3-1
 3.2 Install Gantry..... 3-1
 3.3 Install Push Handle 3-2
 3.4 Install Board Clamps..... 3-2
 3.5 Vacuum Hose Hookup 3-2
 3.6 Electrical Hookup 3-3
 3.8 Sanding Head (Optional Accessory)..... 3-4

SECTION 4 SLAB FLATTENER OPERATION

4.1 **Secure Slab to Bed..... 4-1**
 4.2 Turning on Slab Flattener 4-2
 4.3 Head Up & Down 4-2
 4.4 Start and Stop Cutter Head..... 4-2
 4.5 Operation..... 4-3
 4.6 Sanding..... 4-3

SECTION 5 SLAB FLATTENER ALIGNMENT

5.1 Routine Alignment Procedure..... 5-1
 5.2 Complete Alignment Procedure..... 5-1

SECTION 6 PARTS

6.1 How To Use The Parts List..... 6-1
 6.2 Sample Assembly 6-1
 6.3 Overview 6-2
 6.4 Main Body, Gantry Assembly 6-3
 6.5 Handle, Head Position Index 6-5
 6.6 Push Handle Assembly 6-6
 6.7 Bearings, Up/Down Assembly..... 6-7
 6.8 Up/Down Control..... 6-8
 6.9 Up/Down Handle 6-10
 6.10 Motor Assembly 6-11
 6.11 Control Box..... 6-12
 6.12 Clamps (Hold Down Side Mount) 6-13
 6.13 Decal Kit 6-14
 6.14 Sanding Head (Optional Accessory)..... 6-15

Table of Contents

Section-Page

6.15 Bed Extension (Optional).....6-16

SECTION 7 TROUBLESHOOTING GUIDE

Wood-Mizer® LLC Limited Product Warranty



Wood-Mizer LLC ("Warrantor"), an Indiana corporation with its principal place of business at 8180 West Tenth Street, Indianapolis, IN 46214-2400 USA, warrants to the purchaser ("Purchaser") that for the time periods specifically stated herein and subject to the terms, conditions and limitations stated herein, the equipment manufactured by the Warrantor will be free from defects in material and workmanship attributable to Warrantor so long as, during the warranty periods stated herein, the equipment is installed, operated and maintained in accordance with the instructions provided by Warrantor.

PRODUCT	MODEL CLASS	LENGTH OF WARRANTY		EFFECTIVE DATE
		USA & CANADA	NON USA & CANADA	
Portable Sawmills, Resaws, Edgers	LT, LX, HR, EG	Two years	One year	Date of purchase
Portable Sawmills with Chassis	LT28, LT35, LT40, LT50, LT70, LX450	Two years, excluding the chassis, which chassis shall have a five year warranty	One year	
Industrial Sawmills, Resaws, Edgers	WM, HR, EG, TVS, SVS	One year	One year	Date of purchase or date of installation / training (if applicable), whichever occurs first, not to exceed 6 months from date of purchase
TITAN Industrial	WB, TV, HR, EG, EA, MR	One year	One year	
Material Handling	TWC, IC, TD, LD, GC, CR, CB, CC	One year	One year	
Blade Maintenance Equipment	BMS, BMT, BMST	One year	One year	Date of purchase
Options and Accessories	Various	One year*	One year*	
Moulders, Extractors	MP, MD	Two years	One year	
Kilns	KS, KD	One year	One year	
Slab Flatteners	MB	Two years	One year	
Pallet Equipment	PD, PC	One year	One year	
Log Splitters	FS	One year	One year	
Replacement Parts	Various	90 days	90 days	

* Warranty on Options will match the warranty on the primary equipment when purchased on same invoice.

Exclusions from 90 Day, Limited One Year and Two Year Warranty

Warrantor shall have no responsibility under this warranty for any wear components, including, but not limited to: belts, blade guides, blades, electric motor brushes, drum switches, filters, fuses, hoses, bearings (excluding cylindrical drive bearings), bushings, cable carriers, and spark plugs. All wear components are furnished "as is", without any warranty from Warrantor. This limited warranty does not cover any defects caused by misuse, negligence, alterations, damage due to overload, abnormal conditions, excessive operation, accident, or lack of performance of normal maintenance services.

Several components which are used in the manufacture of the equipment but not manufactured by Warrantor such as cant hooks, power plants, laser sights, batteries, tires, and trailer axles have warranties provided by the original equipment manufacturer (written copies available upon request). Warrantor does not separately warrant such items. Components or equipment manufactured by third parties are not covered by this warranty. Warrantor, however, will provide reasonable assistance to the Purchaser to make claims against any warranties applicable to such component parts as provided by such original equipment manufacturers. Components or equipment manufactured by third parties are not covered by this Warranty.

Five Year Limited Chassis Warranty

The limited five year chassis warranty described above, DOES NOT extend to (a) any damage stemming from accident, improper towing, overload, abuse, misuse, abnormal conditions, negligence, excessive operation, or lack of maintenance, (b) rust caused by exposure to corrosive atmospheric conditions, or (c) the sawmill head, carriage, axle, brakes, or any hydraulic or electrical components attached to the chassis.

Warrantor's Obligations as To Defects

In the event that the equipment fails to perform due to defective materials or workmanship attributable to Warrantor under normal use and service within the established warranty period, Purchaser's sole and exclusive remedy and Warrantor's sole liability shall be to replace or repair, in Warrantor's sole and subjective discretion, any defective part at Warrantor's principal place of business without cost to the Purchaser if such defect exists. The determination of whether a product is defective shall be made by Warrantor in Warrantor's sole and subjective discretion. The Purchaser must notify Warrantor prior to shipping any defective part. Warrantor, at its sole discretion, may cover expenses incurred in shipping the defective part to Warrantor for evaluation; provided, however, that Warrantor will not be responsible for labor, travel time, mileage, removal, installation or incidental or consequential damages. However, any part in excess of 140 pounds must be returned by the Purchaser, to the Warrantor's nearest authorized facility at the Purchaser's expense, if return is requested by Warrantor. Warrantor shall have a reasonable time within which to replace or repair the defective part. If Warrantor determines that the product is not defective under the terms of this warranty in Warrantor's sole and subjective discretion, then Purchaser shall be responsible for any expenses incurred by Warrantor in returning the equipment to the Purchaser.

Limitations and Disclaimers of Other Warranties

EXCEPT FOR THE EXPRESS WARRANTY PROVISIONS STATED ABOVE, WARRANTOR DISCLAIMS ALL WARRANTIES, EXPRESS AND/OR IMPLIED, INCLUDING WITHOUT LIMITATION, THE IMPLIED WARRANTIES OF MERCHANTABILITY, AND FITNESS FOR A PARTICULAR PURPOSE, NON-INFRINGEMENT AND TITLE. No representation or other affirmation of fact by representatives of Warrantor, whether verbal or in writing, including photographs, brochures, samples, models, or other sales aids, shall constitute a warranty or other basis for any legal action against Warrantor. There are no other representations, promises, agreements, covenants, warranties, guarantees, stipulations or conditions, express or implied, by Warrantor except as expressly set forth herein. THE ORIGINAL PURCHASER AND ANY INTENDED USER OR BENEFICIARY OF THIS EQUIPMENT, SHALL NOT BE ENTITLED TO RECOVER ANY INDIRECT, SPECIAL, PUNITIVE, EXEMPLARY, CONSEQUENTIAL, SPECIAL, OR INCIDENTAL DAMAGES OR LOSSES, INCLUDING BUT NOT LIMITED TO, DAMAGES OF LOST PRODUCTION, LOST REVENUE, LOST PRODUCT, LOST PROFITS, LOST BUSINESS, LOSS OF USE, LOSS OF GOODWILL, OR BUSINESS INTERRUPTION, FROM WARRANTOR FOR ANY REASON WHATSOEVER INCLUDING WITHOUT LIMITATION WARRANTY OR DEFECT IN THE PRODUCT REGARDLESS OF THE SOLE, JOINT AND/OR CONCURRENT NEGLIGENCE, BREACH OF CONTRACT, BREACH OF WARRANTY, STRICT LIABILITY IN TORT OR STATUTORY CLAIMS OR OTHER LEGAL FAULT OR RESPONSIBILITY OF EITHER WARRANTOR OR PURCHASER OR ITS EMPLOYEES OR AGENTS. Warrantor does not warrant that its equipment meets or complies with the requirements of any particular safety code or governmental requirements.

Defective items replaced under the terms of this warranty become the property of Warrantor.

Design Changes

Warrantor reserves the right to change the design of its products from time to time without notice and without obligation to make corresponding changes in or to its products previously manufactured.

Rights of Purchasers

The validity and effect of this limited warranty as well as its interpretation, operation and effect, shall be determined exclusively by the principles of law and equity of the State of Indiana, USA. This limited warranty gives Purchaser specific legal rights. Purchaser may also have other rights, which may vary from state to state. Some states may not allow limitations as to the duration of implied warranties or to the exclusion or limitation of incidental or consequential damages, so some of the limitations and exclusions detailed set forth above may not apply. In the event that any one or more of the provisions of this warranty shall be or become invalid, illegal or unenforceable in any respect, the validity, legality and enforceability of the remaining provisions of this warranty shall not be affected thereby.

Interpretations

This Warranty constitutes the entire warranty agreement between Warrantor and Purchaser and supersedes any prior understandings or agreements pertaining to the same subject matter. This warranty cannot be amended except in writing which refers to this warranty which is signed by both Warrantor and Purchaser.

SECTION 1 INTRODUCTION

1.1 About This Manual

This manual replaces any previous information received on your Wood-Mizer® equipment.

The information and instructions in this manual do not amend or extend the limited warranties for the equipment given at the time of purchase.

1.2 Getting Service

For contact information, sales, service, parts, and additional manuals, sign into your account on <https://woodmizer.com>, or call inside the USA: 1-800-553-0182 or from outside the USA: 317-271-1542

1.3 Specifications

Equipment specification are included in the Online Manuals, which are found at <https://apps.woodmizer.com/Manuals/Manuals.aspx?parent=0>.

1.4 Options and Accessories

Your Wood-Mizer product may have options that can be added to the machine or accessories available to purchase. **Option:** Your specific product can have accessories installed at the factory, or installed in the field.

Accessory: Your specific product may have accessories added to the machine that are not available to be installed at the factory. They may only be installed in the field. For example, the PC100 might have Infeed and Outfeed Table accessories.

Power Options: Your specific product power option is detailed based on the specific product number purchased.

This product has the following accessories available:

Part #	Name	Type
LT15BSW	Bed Assy, LT15 - 6'8" Bed Ext, Wide	Accessory
127139	Sanding Head Assembly	Accessory

TABLE 1-1

SECTION 2 GENERAL SAFETY

2.1 Safety Symbols

The following symbols and signal words call your attention to instructions concerning your personal safety. Be sure to observe and follow these instructions.



DANGER! indicates an imminently hazardous situation which, if not avoided, will result in serious injury or death.



WARNING! suggests a potentially hazardous situation which, if not avoided, could result in serious injury or death.



CAUTION! refers to potentially hazardous situations which, if not avoided, may result in minor or moderate injury or damage to equipment.

NOTICE indicates vital information.

2.2 Safety Instructions

OWNER/OPERATOR'S RESPONSIBILITY

The procedures listed in this manual may not include all ANSI, OSHA, or locally required safety procedures. **It is the owner/operator's responsibility and not Wood-Mizer LLC to ensure all operators are properly trained and informed of all safety protocols.** Owner/Operators are responsible for following all safety procedures when operating and performing maintenance to the equipment.

Observe ALL Safety Instructions

NOTICE Read the entire Operator's Manual before operating this equipment.

Note all safety warnings throughout this manual and those posted on the machine.

Be able to access this manual at all times while operating this equipment.

Read additional manufacturer's manuals and observe their applicable safety instructions.

Only persons who have read and understood the entire operator's manual should operate this equipment.

This equipment is not intended for use by or around children.

It is the owner/operator's responsibility to comply with all applicable federal, state, and local laws, rules, and regulations regarding the ownership, operation, and transporting your equipment.

Operators should become thoroughly familiar with and comply with these applicable laws for operating and transporting equipment.



WARNING! Clean sawdust from all guards, vents, control boxes, or any area where sawdust may gather **after each use**. Failure to do so may result in fire, causing death or serious injury.

WEAR SAFETY CLOTHING



WARNING! Secure all loose clothing and jewelry before operating the equipment.



Always wear eye, ear, and foot protection when operating or servicing the equipment.



Wear hand protection while servicing the cutter.



Wear respiratory protection when cutting woods that require it. (It is up to the operator to know which woods require respiratory protection.)

EQUIPMENT SETUP



DANGER! Do not operate the equipment without **all** covers and guards in place.



WARNING! Set up the equipment on solid, level ground.

CHECK EQUIPMENT BEFORE OPERATION



DANGER! Ensure all guards and covers are in place and secured before operating the equipment.



WARNING! Be sure the cutter housing and pulley covers are in place and secure.

KEEP PERSONS AWAY



DANGER! Keep all persons out of the path of moving equipment and lumber when operating equipment or loading lumber.

Ensure the cutter is disengaged and all persons are clear of the cutter head before starting the engine or motor.

KEEP HANDS AWAY

 **DANGER!** Remove power before clearing debris or any other maintenance activity.

Disengage the cutter and shut off the equipment motor before changing the cutter.

Keep hands, feet, and other objects away from cutter guards when operating slab flattener.

 **WARNING!** Avoid contact with any hot parts (motors).

Allow the system to cool sufficiently before beginning any service function, including debris removal.

Avoid contact with sharp edges of the cutter head.

Stay a safe distance from rotating members (shafts, pulleys, fans, etc.) and ensure loose clothing or long hair does not engage rotating members.

Do not spin the cutter head by hand as it may result in serious injury.

KEEP SAFETY LABELS IN GOOD CONDITION

NOTICE Ensure that all safety decals are clean and readable. Replace all damaged safety decals to prevent personal injury or damage to the equipment. Contact your local distributor, or call your Customer Service Representative to order more decals.

NOTICE If replacing a component that has a safety decal affixed to it, ensure the new component also has the safety decal affixed in the same place.

KEEP MACHINE AND SURROUNDING AREA CLEAN

 **WARNING!** Maintain a clean and clear path for all necessary movement around the slab flattener and material stacking areas.

Do not allow children in the area of the equipment.

DISPOSE OF WOOD BY-PRODUCTS PROPERLY

NOTICE Properly dispose of all wood by-products, including sawdust, chips, and other debris.

USE CAUTION WHEN WORKING WITH HEAVY SLABS

 **WARNING!** Always make sure slab is clamped securely before cutting.

2.3 Electrical Lockout Procedures

RULES FOR USING LOCKOUT PROCEDURE

The equipment shall be locked out to protect against accidental or inadvertent operation when such operation could cause injury to personnel. Do not attempt to operate any switch or valve bearing a lock.

LOCKOUT PROCEDURES MUST BE USED DURING, BUT NOT LIMITED TO:

- Changing or adjusting blades
- Unjamming operations
- Cleaning
- Mechanical repair
- Electrical maintenance
- Retrieval of tools/parts from work area
- Activities where guards or electrical panel guard is open or removed

MAINTENANCE HAZARDS INCLUDE, BUT NOT LIMITED TO:

- Blade contact
- Pinch points
- Kickbacks
- Missiles (thrown blades/wood chips)
- Electrical

FAILURE TO LOCKOUT MAY RESULT IN, BUT NOT LIMITED TO:

- Cut
- Crush
- Blindness
- Puncture
- Electrocution
- Serious injury and death
- Amputation
- Burn
- Shock

TO CONTROL MAINTENANCE DANGERS:

- Lockout procedures must be followed (see **OSHA regulation 1910.147**).
- Never rely on machine stop control for maintenance safety (emergency stops, on/off buttons, interlocks).
- Do not reach into moving blades or feed systems. Allow all coasting parts to come to a complete stop.
- Electrical power supply and air supply must both be locked out.
- Where established lockout procedures cannot be used (electrical troubleshooting or mechanical dynamic troubleshooting), alternative effective protective techniques shall be employed which may require special skills and planning.
- Always follow safe operations practices in the workplace.

EQUIPMENT LOCKOUT PROCEDURE

Lockout procedures per OSHA regulation 1910.147, appendix A:

GENERAL

The following simple lockout procedure is provided to assist owner/operators in developing their procedures so they meet the requirements of **OSHA regulation 1910.147**. When the energy isolating devices are not lockable, tagout may be used, provided the owner/operator complies with the provisions of the standard which require additional training and more rigorous periodic inspections. When tagout is used and the energy isolating devices are lockable, the owner/operator must provide full operator protection (see OSHA regulation 1910.147, paragraph (c)(3)) and additional training and more rigorous periodic inspections are required. For more complex systems, more comprehensive procedures may need to be developed, documented, and utilized.

PURPOSE

This procedure establishes the minimum requirements for the lockout of energy isolating devices whenever maintenance or servicing is done on machines or equipment. It shall be used to ensure that the machine or equipment is stopped, isolated from all potentially hazardous energy sources and locked out before personnel perform any servicing or maintenance where the unexpected energization or start-up of the machine or equipment or release of stored energy could cause injury.

COMPLIANCE WITH THIS PROGRAM

All personnel are required to comply with the restrictions and limitations imposed upon them during the use of lockout. The authorized personnel are required to perform the lockout in accordance with this procedure. All operators, upon observing a machine or piece of equipment which is locked out to perform servicing or maintenance shall not attempt to start, energize, or use that machine or equipment.

SEQUENCE OF LOCKOUT

1. Notify all affected personnel that servicing or maintenance is required on a machine or equipment and that the machine or equipment must be shut down and locked out to perform the servicing or maintenance.
2. The authorized employee shall refer to the company procedure to identify the type and magnitude of the energy that the machine or equipment utilizes, shall understand the hazards of the energy, and shall know the methods to control the energy.
3. If the machine or equipment is operating, shut it down by the normal stopping procedure (depress the stop button, open switch, close valve, etc.).

4. De-activate the energy isolating device(s) so that the machine or equipment is isolated from the energy source(s).
5. Lock out the energy isolating device(s) with assigned individual lock(s).
6. Stored or residual energy (such as that in capacitors, springs, elevated machine members, rotating flywheels, hydraulic systems, and air, gas, steam, or water pressure, etc.) must be dissipated or restrained by methods such as grounding, repositioning, blocking, bleeding down, etc.
7. Ensure that the equipment is disconnected from the energy source(s) by first checking that no personnel are exposed, then verify the isolation of the equipment by operating the push button or other normal operating control(s) or by testing to make certain the equipment will not operate.



CAUTION! Return operating control(s) to neutral or "off" position after verifying the isolation of the equipment.

8. The machine or equipment is now locked out.

RESTORING EQUIPMENT TO SERVICE

When the servicing or maintenance is completed and the machine or equipment is ready to return to normal operating condition, the following steps shall be taken.

1. Check the machine or equipment and the immediate area around the machine to ensure that nonessential items have been removed and that the machine or equipment components are operationally intact.
2. Check the work area to ensure that all personnel have been safely positioned or removed from the area.
3. Verify that the controls are in neutral.
4. Remove the lockout devices and re-energize the machine or equipment.

NOTE: The removal of some forms of blocking may require re-energization of the machine before safe removal.



5. Notify affected personnel that the servicing or maintenance is completed and the machine or equipment is ready for use.

PROCEDURE INVOLVING MORE THAN ONE PERSON

In the preceding steps, if more than one individual is required to lock out the equipment, **each shall place his own personal lock on the energy isolating devices.**

2.4 Safety Labels Description

See table below for safety labels description.

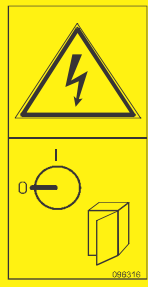
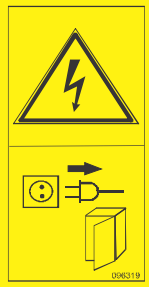
Label View	Description
 <p>09631</p>	096317 CAUTION! Read and understand operator's manual before handling the machine.
 <p>099220</p>	099220 Close guards prior to operating the machine
 <p>096316</p>	096316 Electric box opening is possible with the switch in "0" position only.
 <p>096319</p>	096319 Always disconnect the power cord before opening the electric box.

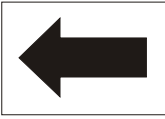
Label View	Description
 <p>524993</p>	524993 Hand injury hazard
	S20097-US Motor rotate direction

SECTION 3 SLAB FLATTENER SETUP

NOTICE! The Slab Flattener is shipped secured to the pallet. Before starting assembly, remove the shipping brackets and straps securing the machine to the pallet.

3.1 Uncrate and Prepare Parts

1. Check your MB100 as soon as it is received. Report any transport damage to Wood-Mizer and shipping agent immediately.
2. Remove shipping straps/crating on flat, level surface.

NOTE: As shipping brackets and straps are removed, bed pieces may slide.

3. Open the parts box and spread the parts for easy visibility.
4. Ensure all parts are present.

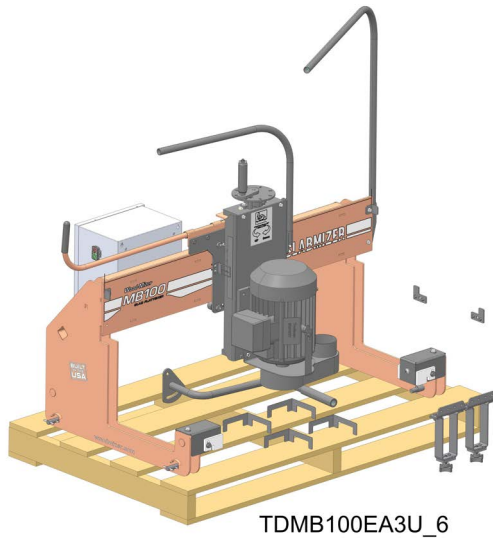

FIG. 3-1

Parts Kit

Description	Quantity
Screw, 3/8-16 x 1/2	4
Rail End Stop	2
Slab Spacer	4
Push Handle	1
Bolt, M12-1.75x30 Carriage	2
Nut, M12x1.75 Hex Nylock	2
Washer, M12 Flat	2
Slab Clamp (lower assembly)	2
Top Clamp Angle	2
Bolt, M6-1x20	2

Description	Quantity
Nut, M6-1.0 Nylock	2
Washer, M6 Flat	2

3.2 Install Gantry



WARNING! Use a fork lift, crane, or other lifting device to remove the gantry from the packing crate. Failure to follow this may result in serious injury or death.

The MB100 can be installed on an existing LT15W saw-mill bed or bed extension. Standalone bed sections (LT15BSW) can also be purchased separately to install the gantry upon. See form 2484 for LT15BSW assembly and leveling instructions.

1. Set the bed on firm, level ground and level the slab flattener.
2. Place Gantry onto assembled bed section. Use care when mounting gantry to avoid damage.
3. Align bed rail between cam followers and track wipers.
4. With the Gantry in place, secure it to bed assembly by releasing spring loaded latch pins onto side of bed rail.

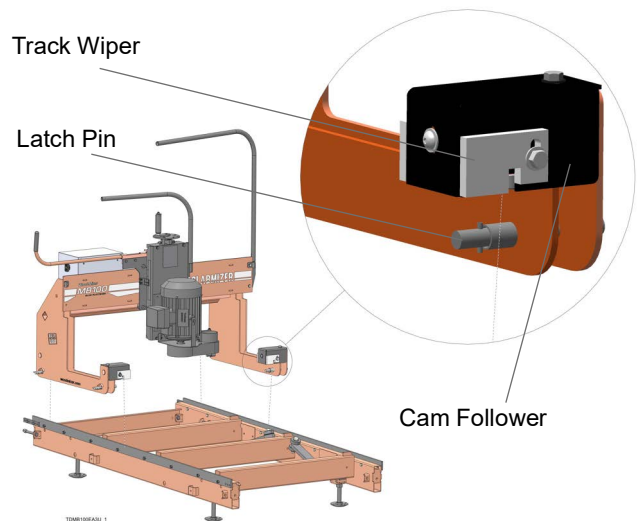

FIG. 3-2

IF INSTALLING THE MB100 ON A STAND ALONE LT15BSW BED EXTENSION, END STOPS MUST BE INSTALLED ON THE BED FRAME.

1. Remove bed extension joining plates.
2. Install rail end stops as shown below.

NOTE: There are 2 end stops installed on the same bed rail.

3 Slab Flattener Setup

Install Push Handle

TDM100EA3U
TD127291

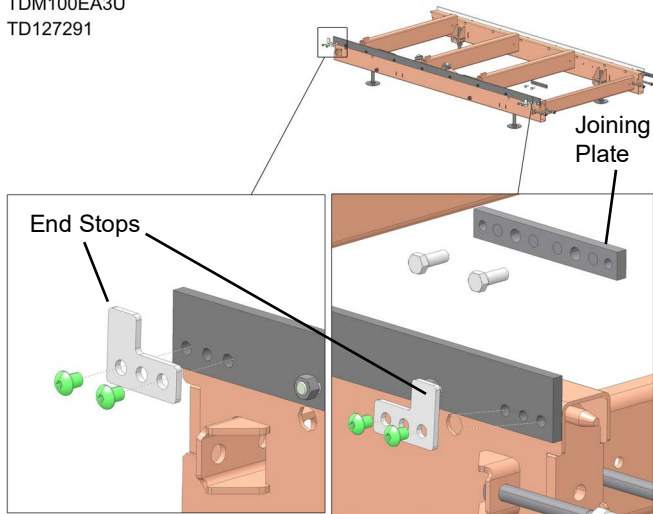

FIG. 3-3



DANGER! If attached to a trailered sawmill bed, the MB100 must be removed from the bed prior to transporting.

3.3 Install Push Handle

1. Place (2) M12 -1.75x 30 carriage bolts in square holes on side of gantry opposite vacuum hose arm.
2. Align mounting holes as shown in FIG. 3-6.
3. Fasten with (2) M12 Flat Washers and (2) M12 Nylock Hex Nuts.

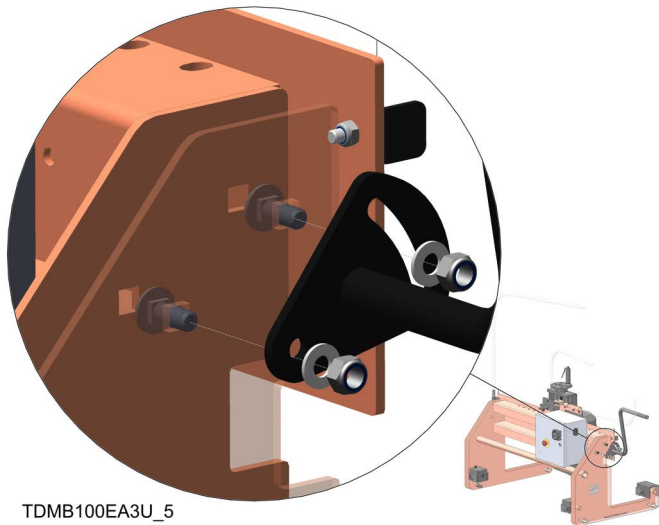

TDMB100EA3U_5

FIG. 3-4

3.4 Install Board Clamps

1. Loosen the adjustment knob until the clamping screw is flush with or below the lower clamp bolts.
2. Install clamp on bed rail as shown in FIG 3-5.
3. Use (2) M6-1x20 Bolts, (2) M6 Flat Washers, and (2) M6 Nylock Nuts to attach Top Clamp Angle.
4. Slide clamp to desired position and tighten adjustment knob.

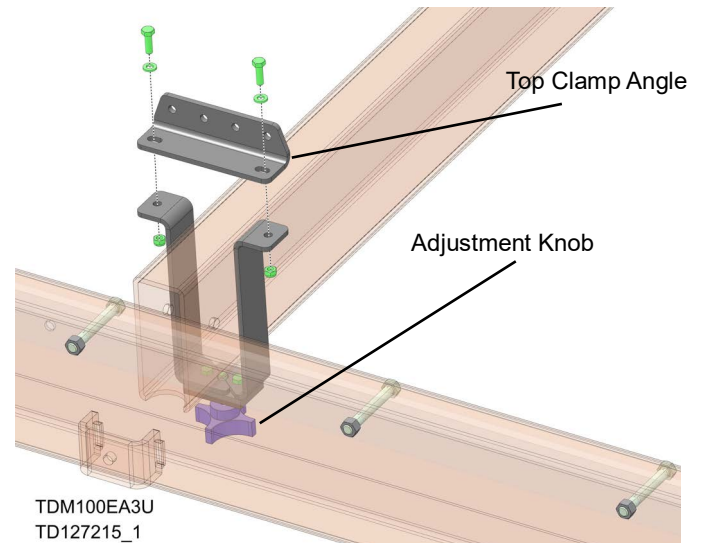

FIG. 3-5

3.5 Vacuum Hose Hookup

NOTICE! Connect a sawdust collection system when operating under roof or indoors (electric only).

Secure the Vacuum Hose to the Vacuum Hose Arm using appropriately sized hose clamps or zip ties. (Minimum 5 locations as shown in FIG 3-6).

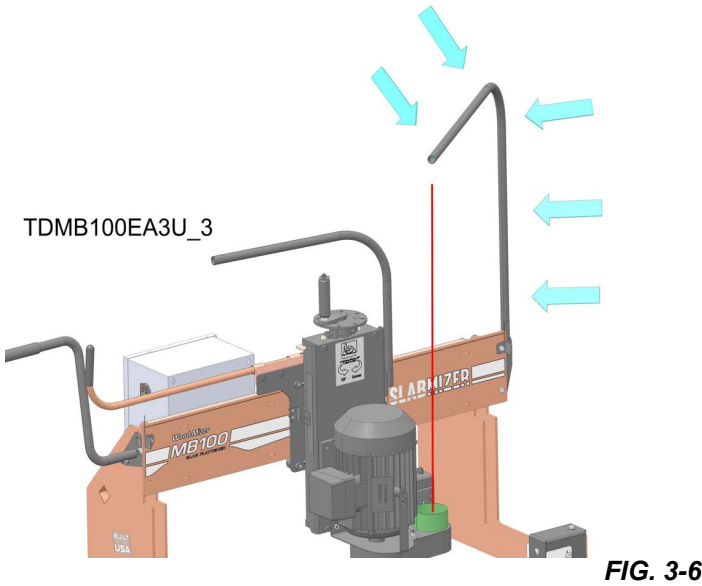

FIG. 3-6

3.6 Electrical Hookup

NOTICE! This information is provided so that you may have your site prepared for installation of your electric Slab Flattener. In order to properly install your Slab Flattener, you need to:

1. **Prepare a firm, level area where the Slab Flattener can be operated.** There should be enough room around the Slab Flattener for operators, sawdust removal, material loading and board removal.
2. **Have a qualified electrician install the power supply before receipt of your Slab Flattener.** The power supply must meet the enclosed specifications concerning wire size, fused disconnect, and voltage. The electrical installation must also meet local codes.
3. **Be sure the power supply cables are properly secured.** Secure the power supply cables in the provided power cord boom system.
4. **Have a qualified electrician present when the Slab Flattener is to be installed.** All relevant motor specifications and wiring information is provided. When scheduling an electrician for the day of installation, please confirm that they have enough of the proper size cable (wiring). Many electricians may not stock the cable, which could seriously delay installation and training.

ELECTRIC WIRING

DANGER! Make sure all electrical installation, service and/or maintenance work is performed by a qualified electrician and is in accordance with applicable electrical codes.



WARNING! Make sure that the machine you have purchased can be powered with the provided power source before making any connections. Do not connect the machine to the improper power source. Serious injury, death or damage to the equipment will result.

All electrical installation must meet local electrical codes. Install a disconnect switch within sight of the machine. Short circuit and over-current protection for the control system must be provided. Use electrical nameplate information to size this protection and wiring.

 Wood-Mizer®	
Voltage	220VAC +/- 10%
Phase	1Ph
Frequency	50/60Hz
FLA, Machine	20.2A
FLA, Largest	20.2A
Wiring Diagram	MB100
SCCR	5kA

NOTE: The MB100 runs on 1PH power. The control cabinet contains a drive which converts 1PH to 3PH only for the motor.

Route the incoming power supply to the main electrical control cabinet. Create a hole in the box and route the cable through the box and secure the cable properly. Connect to cable wires to the power disconnect in the Upper-right corner of the cabinet. This is component Q1, terminals L1, L2, L3. Connect the ground wire to a panel mount stud.

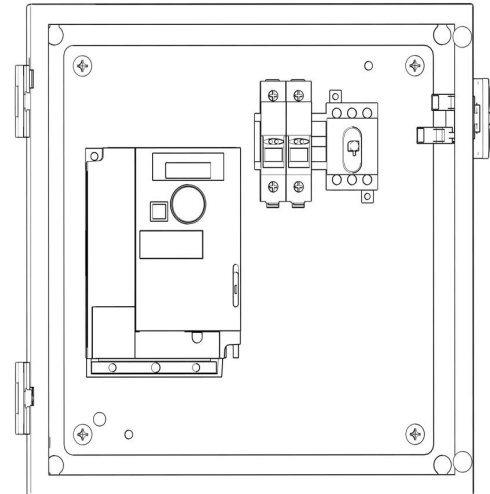

TDMB100EA3U
TD127046_1

FIG. 3-7

SLAB FLATTENER BLADE MOTOR SPECIFICATIONS.

Electric Blade Motor Specifications	MB100EA3U
Horsepower	3
RPM	5500
Volts	240
Full-Load Amps	20.2
SF	1.25
NOM EFF	86.5
Frame	182E
Design	B
AMB	40° C
INS	F3
PH	3
ENCL	TEFC
Code	K

TABLE 7

3.8 Sanding Head (Optional Accessory)

1. To install the Sanding Head, fit the Orbital Balance onto the retaining washer before threading the (2) M5x18 SH Bolts. Tighten the two bolts with 4mm hex wrench as shown in 3-8.
2. Thread the Sanding Pad onto the Sanding Stud using 19mm wrench.



CAUTION: Ensure the Orbital Head is fully seated to prevent cross threading of the bolts.

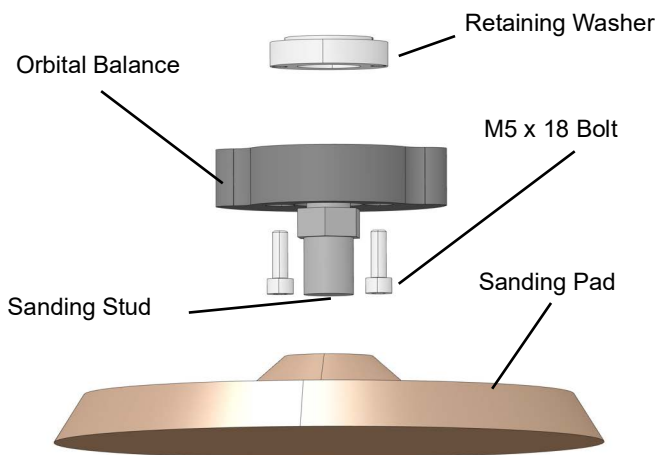

TD127000
TD127139_1

FIG. 3-8

SECTION 4 SLAB FLATTENER OPERATION

4.1 Secure Slab to Bed

NOTE: A variety of clamp configurations can be used to best suit the slab being flattened.

CLAMP AGAINST CANT STOPS

1. Lay board flat on bed, firmly against cant stops.
2. Slide clamp plate against slab edge.
3. Tighten adjustment knobs to secure clamps.

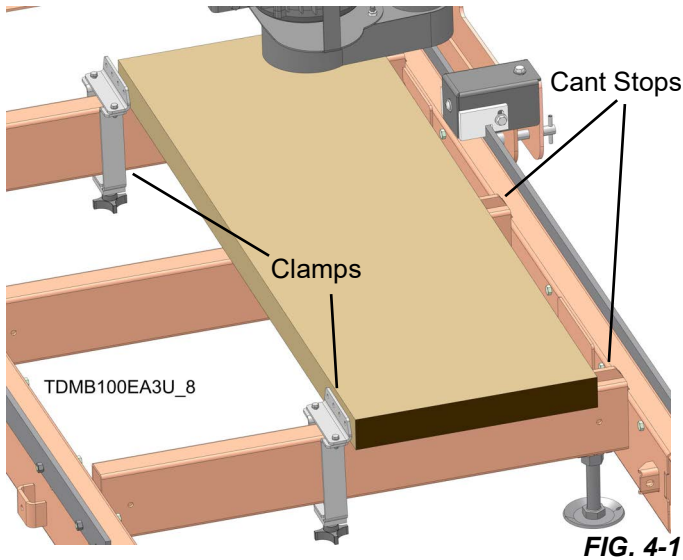

FIG. 4-1

SCREW SLAB EDGE

1. Secure one clamp to each edge of slab using wood screws.
2. Pull slab tight to bed by tightening clamp adjustment screws.

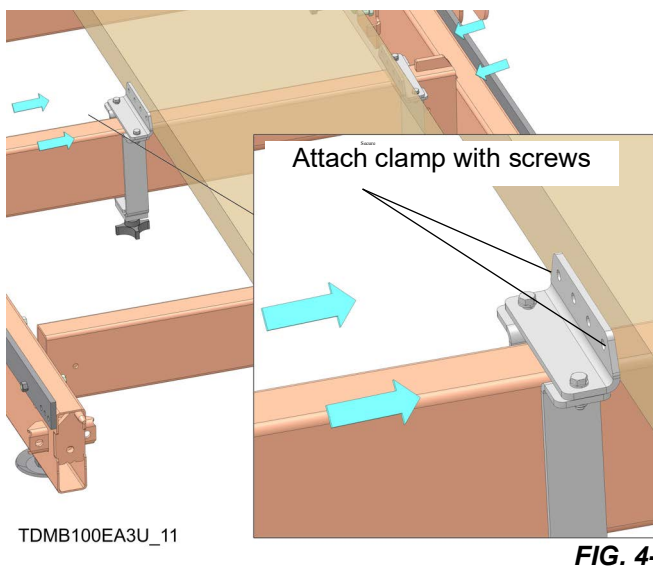

FIG. 4-2

SCREW BOTTOM SURFACE

1. Secure clamps to bottom of slab using wood screws.
2. Pull slab tight to bed by tightening clamp adjustment screws.

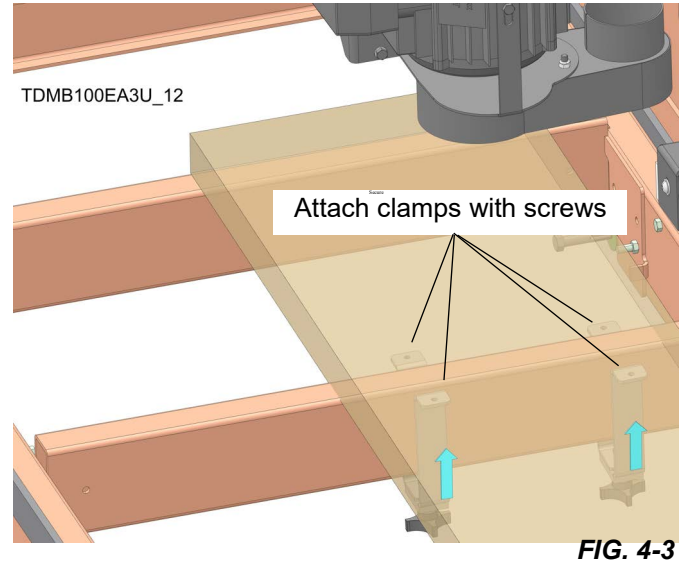

FIG. 4-3

If flattening a slab wider than the bedrail, install slab spacers to elevate slab above cant stops.

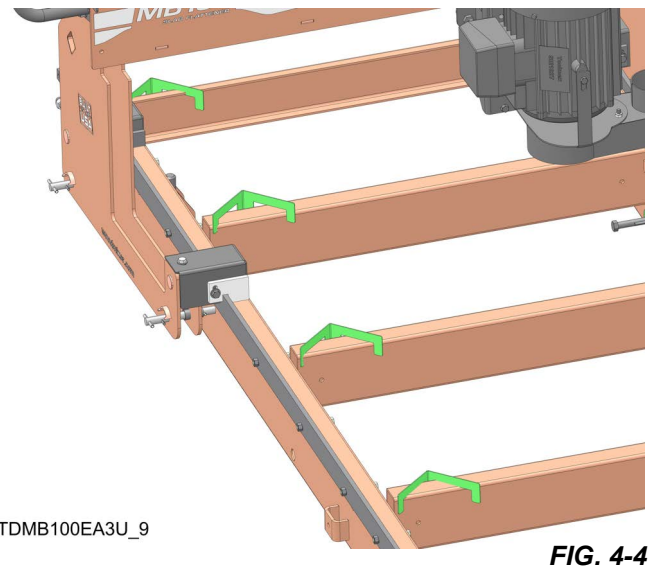

FIG. 4-4

4 Slab Flattener Operation

Turning on Slab Flattener

4.2 Turning on Slab Flattener

1. Turn Disconnect Switch to ON position.
2. Disengage the E-Stop located on unit's control box. When Disengaged E-Stop will unlock and knob will pop outwards.

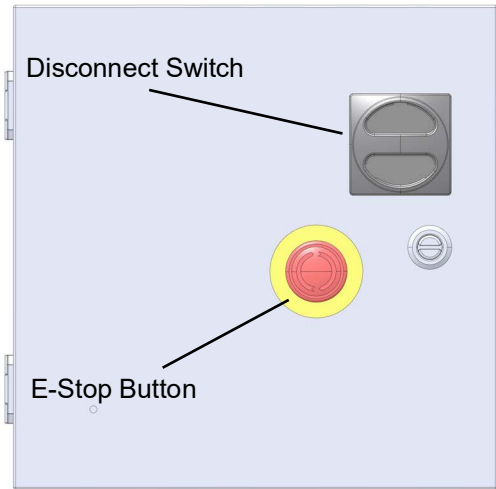

TD127046_2

FIG. 4-5

4.3 Head Up & Down

The Cutter Head Up & Down Motion is controlled manually by the Hand Turning Wheel located on the top of the gantry.

1. Squeeze the handle to unlock the Turning Wheel to make height adjustments.
2. Turn the hand-wheel clockwise to lower the head and counter-clockwise to raise the head.
3. Height adjustments are made in increments of 1/64" with the positive stops located on the turning wheel.

One full turn of the wheel adjusts 1/8".

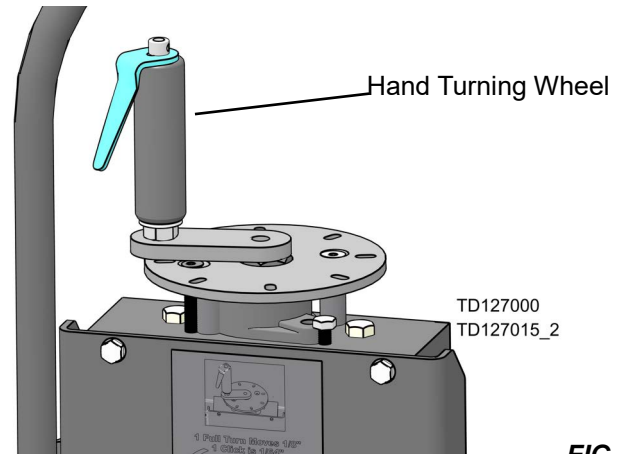

FIG. 4-6

4.4 Start and Stop Cutter Head

1. MB100's Cutter Head is activated using Motor Start (I) & Stop (O) buttons located on side of control box.
2. Ensure cutter head is clear of material prior to turning on.



WARNING! Before activating the cutter head clear the working area of any tools, debris or other obstacles that could cause interference with cutter.



WARNING! Make sure the user and all personnel are clear of the cutter head before activating. Failure to do so can result in Serious Injury or death.

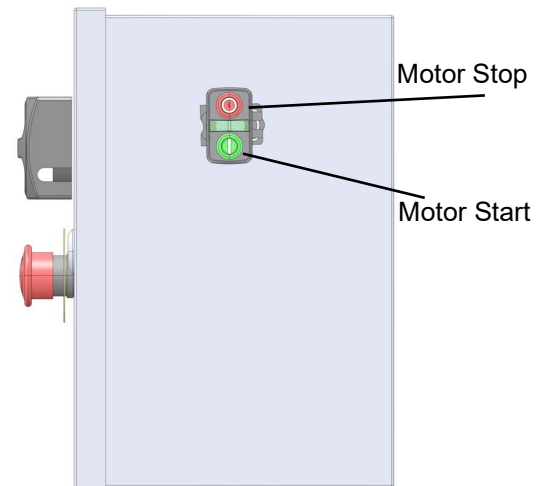

TD127046_3

FIG. 4-7

4.5 Operation

Use the Push Handle and Head Position Index Handle (HPIH) to control the Cross Feed and Drive of the cutter head.



CAUTION When operating the Slab Flattener, use consistent controlled feed rates to prevent damaging the material surface and/or the cutter head.

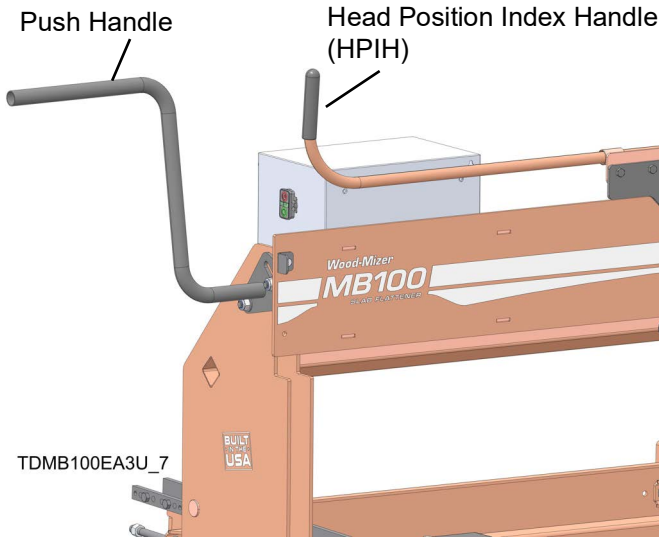

FIG. 4-8

1. With cutter turned OFF, move cutter head across slab to find highest point.
2. Set height adjustment to remove no more than 1/8" from that high point.
3. Start with HPIH in furthest indexing slot from handle.
4. Use Push Handle to drive cutter forward across slab.
5. Turn the HPIH to lift the indexing pin and move one slot over.
6. Use Push handle to drive cutter back across slab.

7. Continue until the entire slab has been flattened.

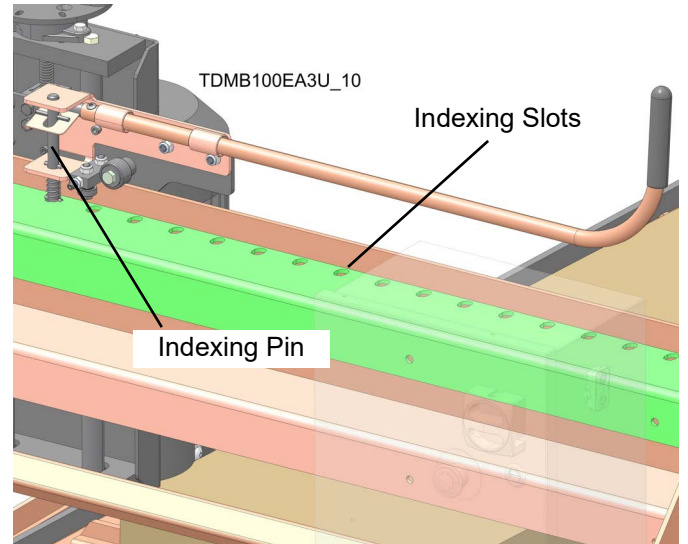

FIG. 4-9

If needed, use the hand turning wheel to lower the cutter head and repeat the flattening process.

4.6 Sanding

1. See Section 3.8 for installing the Sanding Head.
2. Sanding pressure can be adjusted by raising or lowering the Head no more than 1/64" Per pass. (positive stops located on the hand wheel are set to 1/64" per pass).
3. Use the Push Handle and Head Position Index Handle (HPIH) to control the Cross Feed and Drive of the sanding head.



CAUTION! Do not let sanding head leave slab surface otherwise, may cause damage to the sanding head or the sandpaper may detach.

SECTION 5 SLAB FLATTENER ALIGNMENT

Two alignment procedures are available to realign the Slab Flattener if necessary. The Routine Alignment instructions should be performed as necessary to solve planing problems not related to cutter performance. The Complete Alignment procedure should be performed approximately every 1500 hours of operation or as needed.

5.1 Routine Alignment Procedure

Misalignment of the cutter head can cause a variety of issues. It is important that the cutter head is parallel to the cutting surface in order to achieve optimal planing and sanding results.

Level the frame and adjust the saw head as described in Section 3.

5.2 Complete Alignment Procedure

ALIGNMENT FRONT & REAR

The Cutter Head is aligned front and rear by adjusting the set screws on the Up & Down Mounting Plate. See FIG. 5-1.

- Loosen alignment bolt nut on bottom of back-side of motor mounting plate.
 - Tighten alignment bolt to bring front of cutter downward.
 - Loosen rear bolt to raise the front of cutter head upward.
- Secure opposite alignment bolt.

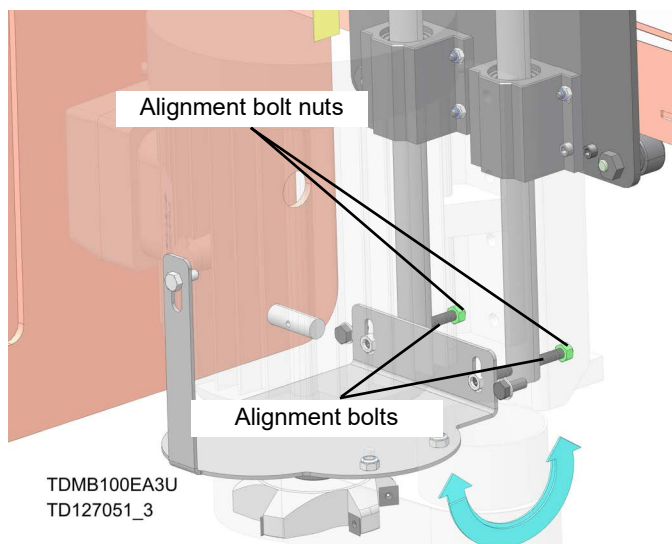

FIG. 5-1

ALIGNMENT SIDE TO SIDE

- Locate (4) cam nuts on back plate of up/down assembly. See FIG. 5-2
- Turn both cams on one side of motor equal amounts to raise or lower that side of cutter head.

Do not over tighten the cams as this will cause restriction to the Cross Feed movement.

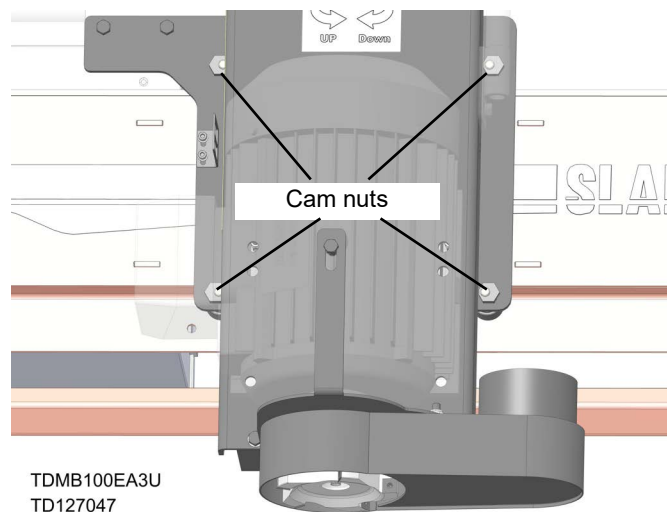

FIG. 5-2

ADJUSTING THE SCALE

- Locate scale measuring strip at side of up/down mounting plate. See FIG. 5-3
- Measure distance from bed rail surface to cutter head.
- Compare measurement to scale reading.
- If scale requires adjusting, loosen (2) socket head cap screws.
- Adjust scale's sight line to correct measurement.
- Tighten (2) SHC screws.

DUST HEAD

1. Raise or lower up/down so that cutting head is sitting on the surface of material.
2. Adjust dust head, leaving 1/8" gap between surface of material and bottom of Dust Head.
3. Use Dust head adjustment screws for moving dust head up and down as needed. See FIG. 5-4

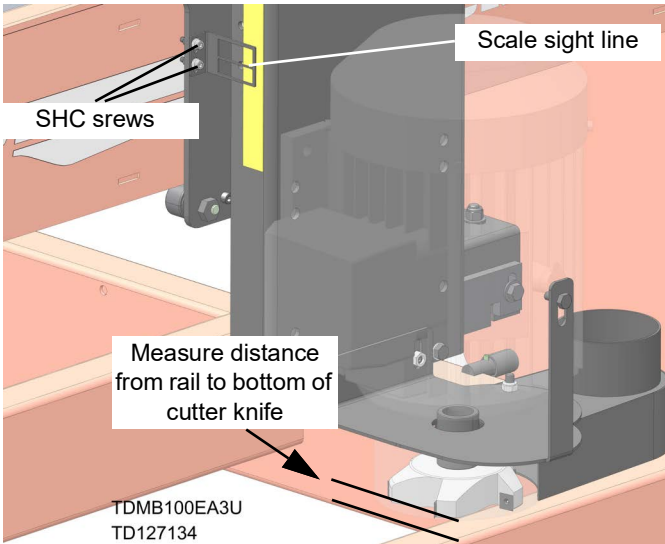

FIG. 5-3

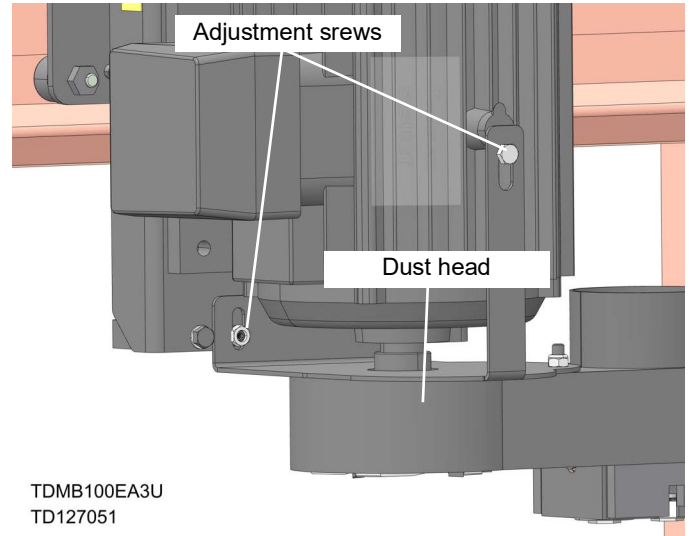

FIG. 5-4

SECTION 6 PARTS

6.1 How To Use The Parts List

- Use the table of contents to locate the assembly that contains the part you need.
- Go to the appropriate section and locate the part in the illustration.
- Use the number pointing to the part to locate the correct part number and description in the table.
- Parts shown indented under another part are included with that part.

To Order Parts

- From the continental US, call **1-800-525-8100** to order parts. Have your customer number, vehicle identification number, and part numbers ready when you call.
- From other international locations, contact the Wood-Mizer distributor in your area for parts.

6.2 Sample Assembly

REF	PART #	DESCRIPTION	COMMENTS	QTY.
	012345	SAMPLE ASSEMBLY, COMPLETE	INCLUDES ITEMS 1-6	1
1	F02222-22	Sample Part		1
2	F03333-33	Sample Part		2
	098765	Sample Subassembly	Includes items 3-6	1
3	S04444-44	Subassembly Sample Part		1
4	K55555	Subassembly Sample Part		1
	054321	Sample Sub-Subassembly	Includes items 5-6	2
5	022222	Sub-Subassembly Sample Part		1
6	F10234-56	Sub-Subassembly Sample Part		1

The Sample Assembly, Complete, part number 02345 (top level assembly) includes two parts (F0222-22 and F0333-33) and the 098765 subassembly.

Subassembly 098765 contains two parts (S04444-44 and K55555) and two copies of sub-subassembly 054321.

Each sub-subassembly 054321 contains two parts (022222 and F10234-56).

6.3 Overview

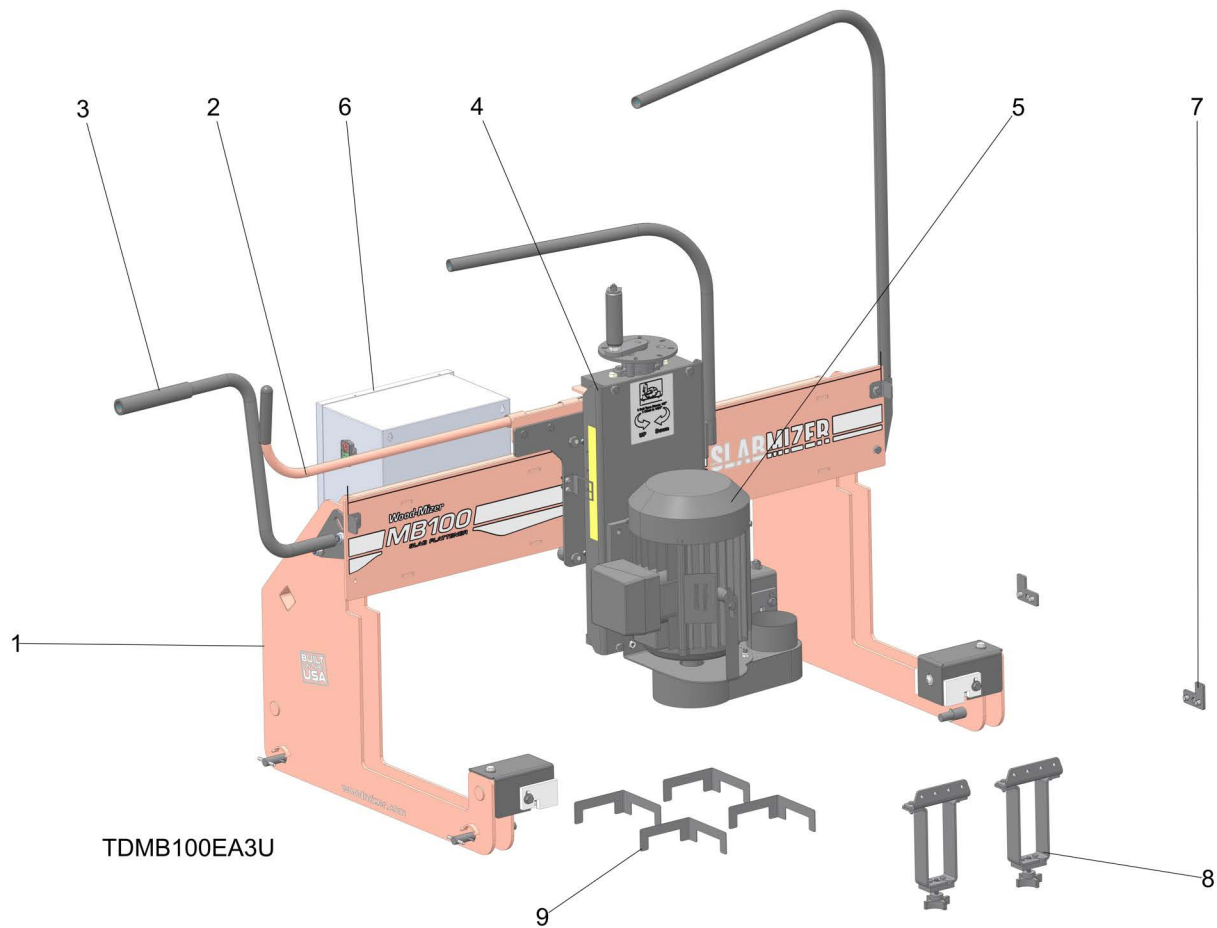

TDMB100EA3U

REF	PART #	DESCRIPTION	COMMENTS	QTY.
1	127017	Assembly, Gantry	(See Section 6.4)	1
2	127274	Handle, Head Position Index	(See Section 6.5)	1
3		Assembly, Push Handle	(See Section 6.6)	1
4	127047	Assembly, Up/Down	(See Section 6.8)	1
5	127014	Assembly, Motor	(See Section 6.10)	1
6	127046	Assembly, Control Box	(See Section 6.11)	1
7	127291	Stop, End	(See Section 6.12)	2
8	127215	Assembly, Hold Down Side Mount		2
9	127290	Slab Spacer		4
	133078	Decal Kit, MB100	(See Section 6.13)	1

6 Gantry

Main Body, Gantry Assembly

6.4 Main Body, Gantry Assembly

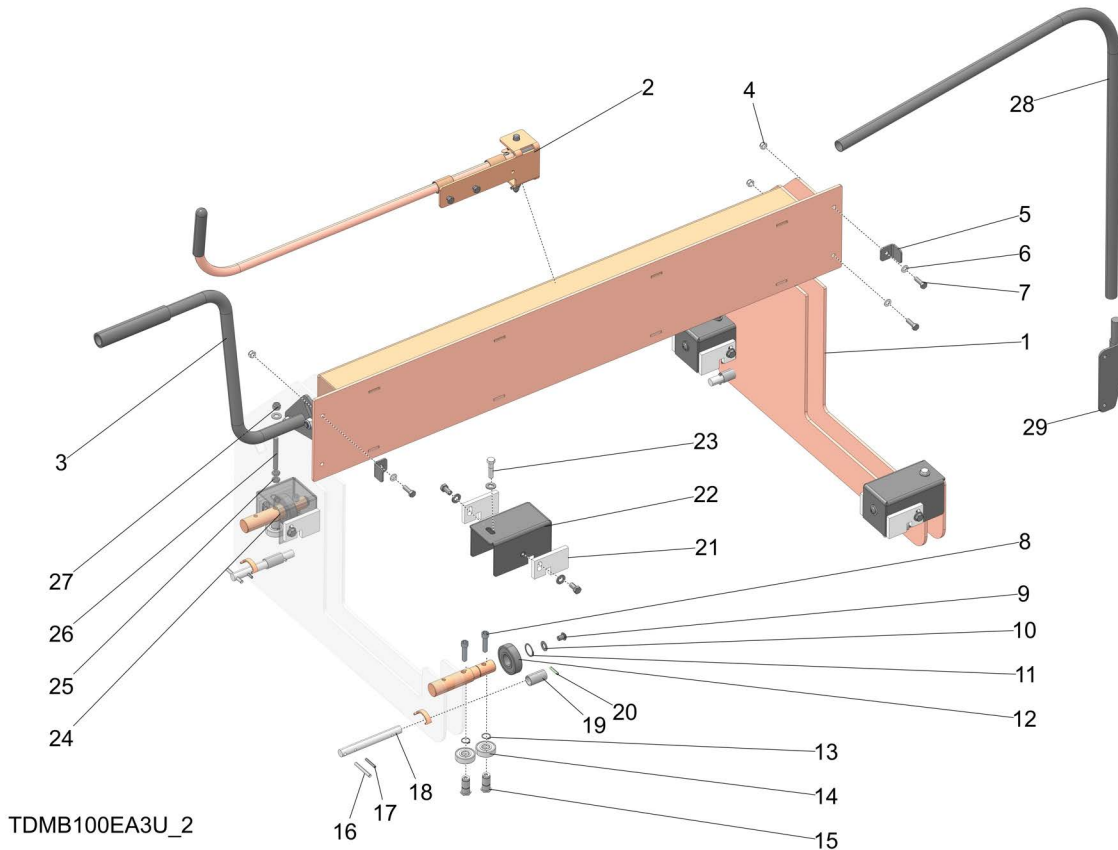

REF	PART #	DESCRIPTION	COMMENTS	QTY.
1	127017	Weldment, Gantry		1
2	127272	Handle, Head Position Index	(See Section 6.5)	1
3	127265	Handle, Push	(See Section 6.6)	1
4	F05010-132	Nut, M8-1.25 Hex Nylock		21
5	127164	Plate, Head Stop		2
6	f05026-4	Washer, M8 Flat		3
7	F05004-40	Bolt, M8x1.25x25 HH FT		3
8	F05007-36	Screw, 3/8-16x1 1/2 SH BO		6
9	F05007-211	Screw, 3/8-16 x 1/2 BHCS BO		1
10	F05011-3	Washer, 3/8 Flat SAE		16
11	F04254-26	Ring, 25mm 5100-98 OR		4
12	P08066	Bearing, 6305 62ODx25IDx17W		4
13	F04254-2	Ring, 5/8 OR 5100-62		8
14	P06030-1	Bearing, 5/8x1.7548x.4724		8
15	110404	Shaft, Roller Upright		8

REF	PART #	DESCRIPTION	COMMENTS	QTY.
16	F05012-46	PIN, 1/4X2 ROLL		4
17	F05012-16	Pin, 3/16x1 1/4 Roll		4
18	014899	Shaft, Lower Upright Guide		4
19	P07997	Spring, 7/8OD x 1 1/2		4
20	F05012-11	Pin, 3/16x1 Zinc Roll		4
21	014906	Wiper, LT15 Track		8
22	015846	Cover Wldmt, LT15 Rail		1
23	F05007-78	Bolt, 3/8-16X1 1/2 HH Gr5, Znc		2
24	127271	Cover Wldmt, LT15 Rail		1
25	F05010-29	Nut, 3/8-16 Jam		4
26	F05004-223	Stud, 3/8-16 x 3 B7 Alloy Znc		2
27	F05010-10	Nut, 3/8-16 Hex Nyl Lock		2
28	127161	Mount, Vacuum Hose Arm		1
29	127292	Arm, Vacuum Hose		1

6.5 Handle, Head Position Index

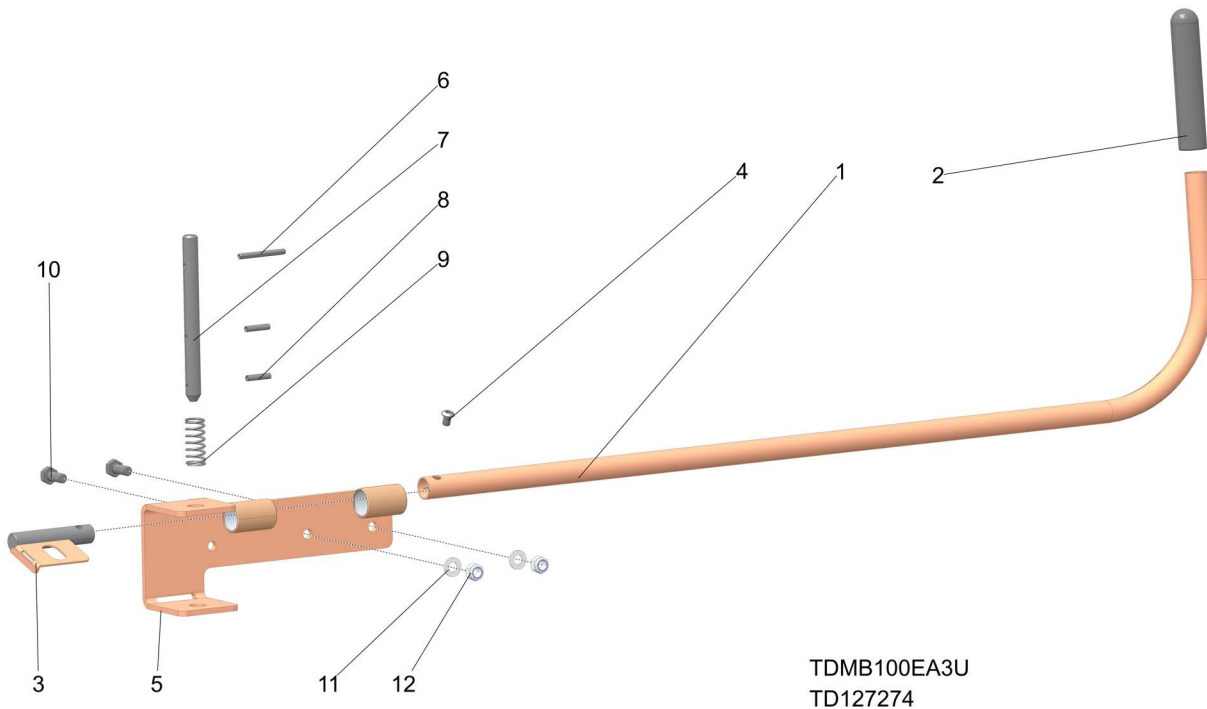

REF	PART #	DESCRIPTION	COMMENTS	QTY.
	127274	Handle, Head Position Index		1
1	127277	Tube, Head Position Index Handle		1
2	127286	Sleeve, Foam		1
3	127282	Guide, Head Position Index Handle		1
4	F05005-62	Screw, 1/4-20x3/8 SBHC		1
5	127273	Mount, Head Position Index Handle		1
6	F05012-103	Pin, 3/16x1 3/4 Roll Zinc		1
7	127276	Pin, Indexing		1
8	F05012-19	Pin, 3/16x7/8 Roll		2
9	127285	Spring, Indexing Pin		1
10	F05021-2	Bolt, M8-1.25x20 Class 8 HH		2
11	F05026-4	Washer, M8 Flat		2
12	F05010-132	Nut, M8-1.25 Hex Nylock		2

6.6 Push Handle Assembly

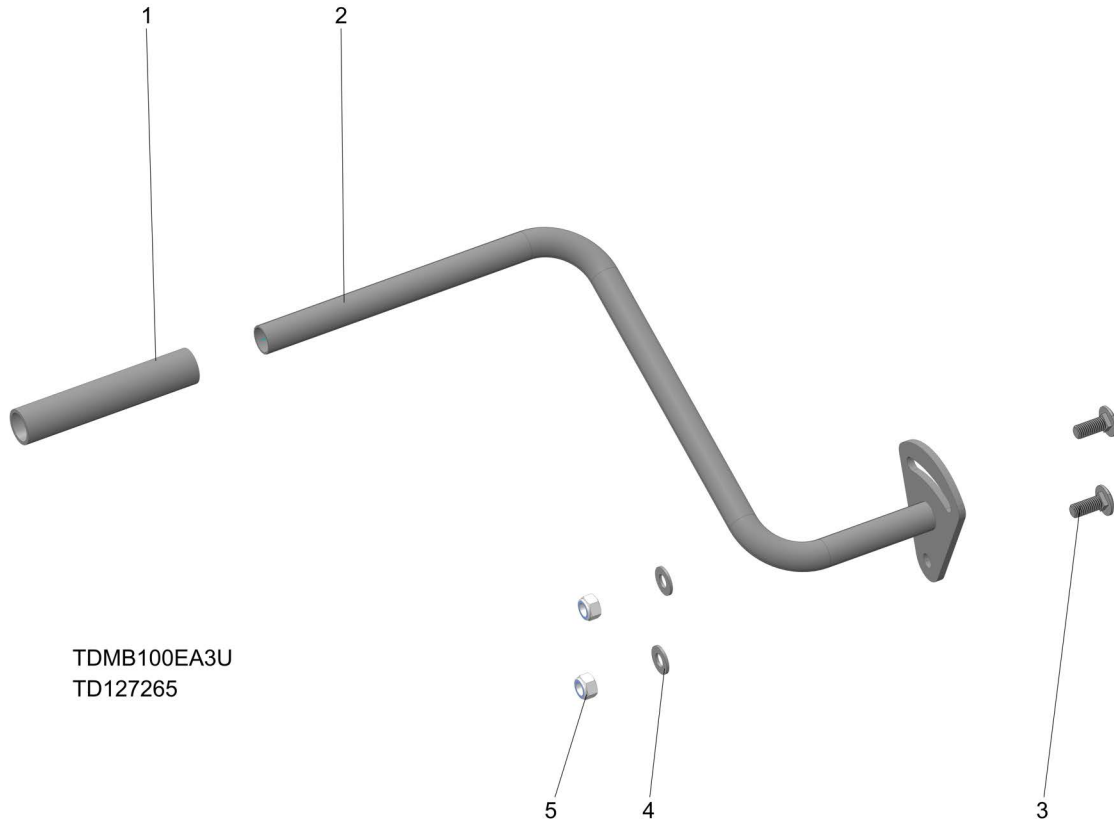

REF	PART #	DESCRIPTION	COMMENTS	QTY.
1	127118	Sleeve, Foam		1
2	127265	Weldment, Push Handle		1
3	F05023-33	Bolt, M12-1.75x30 Class 8.8 FT Carriage Zinc		1
4	F05011-124	Washer, M12 Flat Zinc		1
5	F05010-209	Nut, M12x1.75 Hex Nylock Zinc		1

6.7 Bearings, Up/Down Assembly

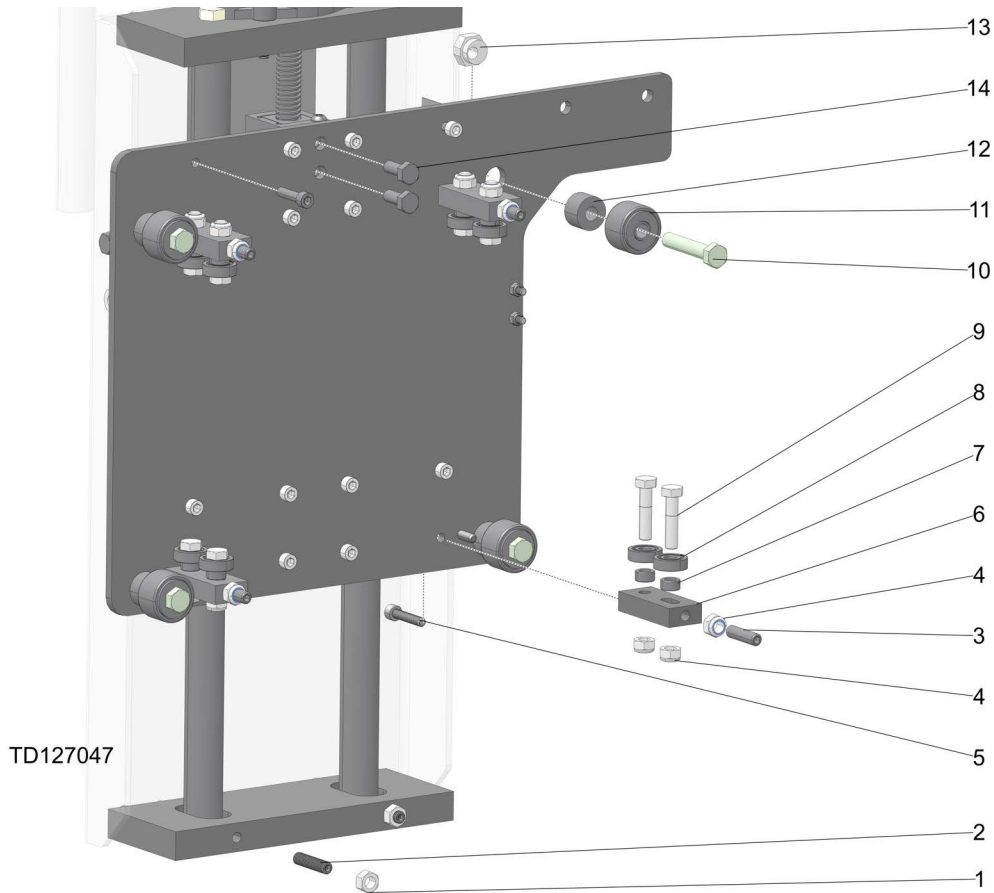

REF	PART #	DESCRIPTION	COMMENTS	QTY.
1	F05027-17	Nut, M8-1.25 Swaged Hex		4
2	127066	Setscrew, M8x20		4
3	F05021-22	Screw, M8-1.25x30mm SH Oval Pnt Set		4
4	F05010-132	Nut, M8-1.25 Hex Nylock		15
5	F05020-25	Screw, M6-1x30 SHC		5
6	127059	Block, Bearing Mount		4
7	127061	Spacer, Bearing		8
8	127130	Bearing, Ball 608		1
9	F05021-50	Screw, M8-1.0 x 35 SHC		8
10	F05007-158	Bolt, 3/8-16 x 2 HH Tap (FT) Grd 5		4
11	127062	Bearing, Cam 1 1/4		4
12	127060	Spacer, Bearing		4
13	127063	Nut, Cam Vertical Adjustments		4
14	F05021-2	Bolt, M8-1.25x20 Class 8 HH		2

6.8 Up/Down Control

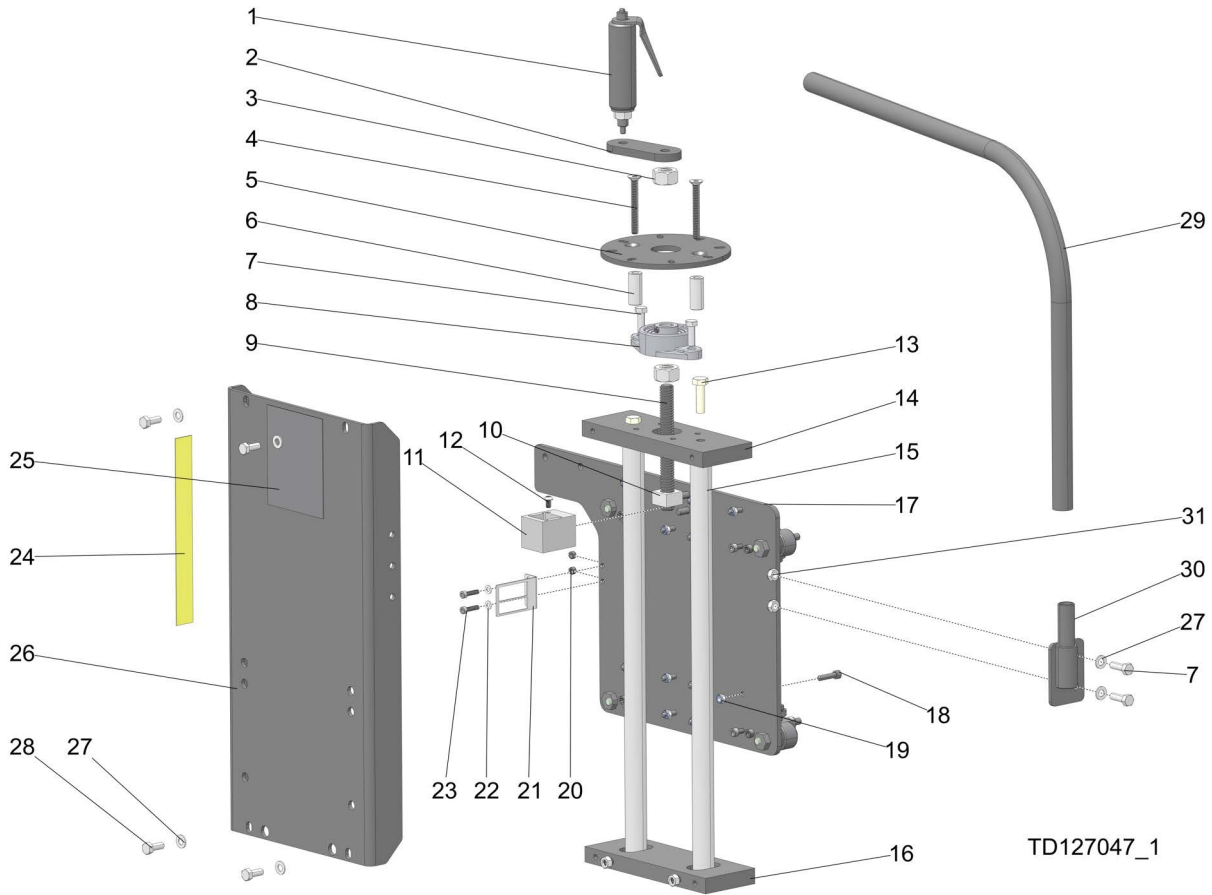

TD127047_1

REF	PART #	DESCRIPTION	COMMENTS	QTY.
1	047685	Handle Assy, Edger	(See Section 6.9)	1
2	127111	Block, Up/Dn Handle		1
3	127110	Nut, Acme 5/8-8		2
4	F05021-56	Bolt, M8-1.25x70mm FHS FT BO		2
5	127191	Plate, UP/Down Latch		1
6	127133	Tube, Spacer		2
7	F05004-40	Bolt, M8x1.25x25 HH FT		4
8	127112	Bearing, 5/8" Bore 2 Bolt Flange		1
9	127109	Rod, Acme 5/8-8x 11 7/8		1
10	127131	Nut, Acme 5/8-8 Brass		1
11	127132	Block, Amce Nut Mount		1
12	F05020-92	Bolt, M6-1x10mm BHCS BO		1
13	F05022-18	Bolt, M10-1.50 x 35MM HH Gr 8.8		2
14	127190	Flat, Rod Mount Top		1

6

Up/Down Control

REF	PART #	DESCRIPTION	COMMENTS	QTY.
15	127188	Rod, 1" Chrome		2
16	127192	Flat, Rod Mount Bottom		1
17	127193	Plate, Back		1
18	F05004-283	Bolt, M6-1.0x25mm SHCS		11
19	F05010-200	Nut, M6-1.0 Nylon Lock		12
20	F05027-3	Nut, M5-.8 Class 8 Hex Nyloc		2
21	127134	Pointer		1
22	F05026-18	Washer, M5 Flat		2
23	F05020-65	Screw, M5-0.8 x 20mm SHC; 18-8SS		2
24	127067	Scale, Up Down		1
25	127207	Decal		1
26	127189	Plate, Motor Mount		1
27	F05026-4	Washer, M8 Flat		4
28	F05021-2	Bolt, M8-1.25x20 Class 8 HH		4
29	127162	Tube, Arm Hose		1
30	127289	Mount, Arm Hose Tube		1
31	F05010-132	Nut, M8-1.25 Hex Nylock		2

6.9 Up/Down Handle

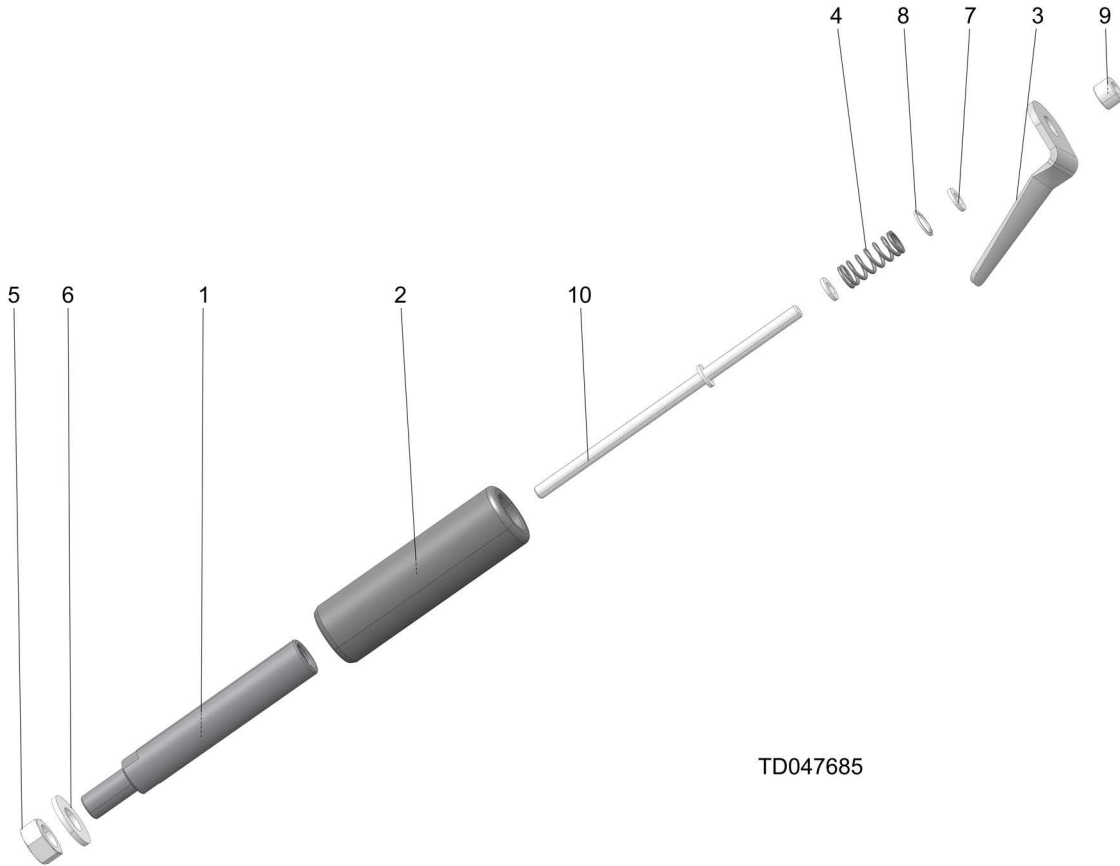

REF	PART #	DESCRIPTION	COMMENTS	QTY.
	047685	Handle Assy, Edger		1
1	047686	Shaft, Edger Handle		1
2	047688	Handle, 25/64IDx1 1/4ODx4 1/8 Plastic		1
3	047689	Plate, Edger Handle		1
4	047690	Spring, .48Diax1.5 Long SS Compression		1
5	F05010-35	NUT, 1/2-13 FREE HEX, ZINC		1
6	F05011-2	Washer, 1/2 SAE Flat		1
7	F04254-47	Ring, 1/2 ID IR Retaining Snap		1
8	047705	Spacer, .26 IDx.480 ODx1/16		2
9	031975	Collar, 1/4 ID Shaft		1
10	006496	Shaft Assy, TBE Handle		1

6.10 Motor Assembly

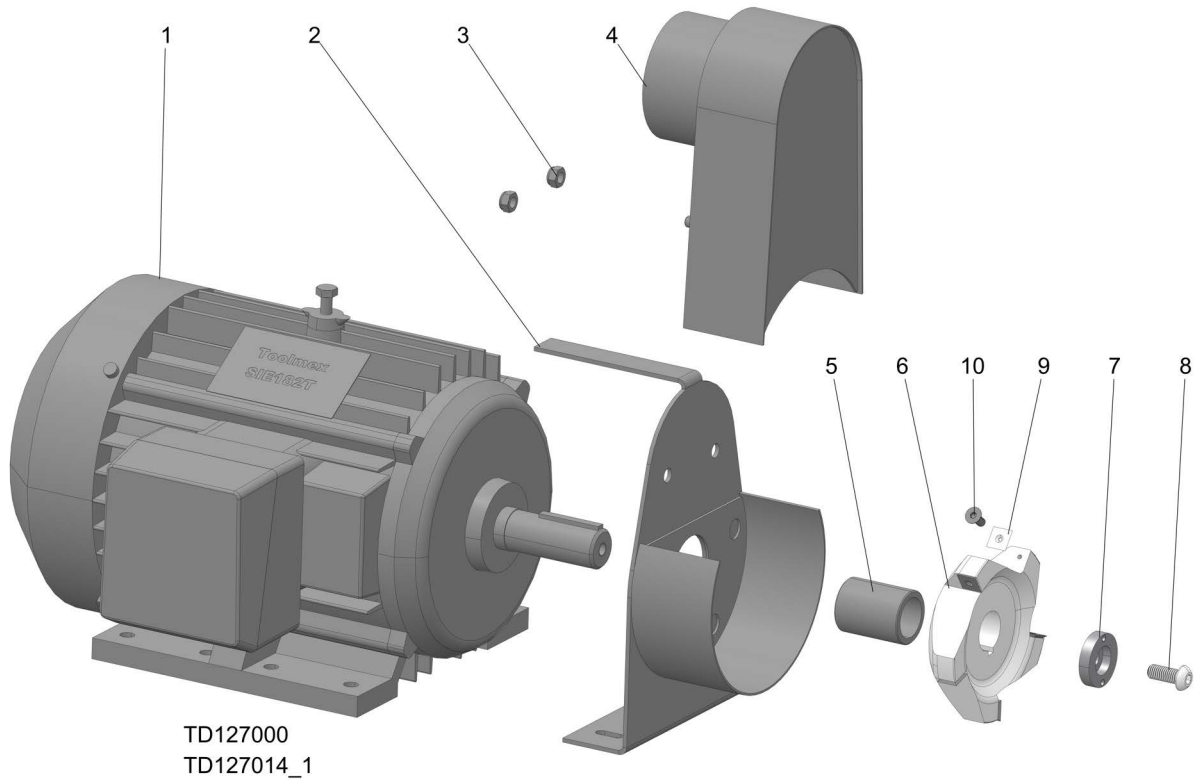

REF	PART #	DESCRIPTION	COMMENTS	QTY.
	127014	MOTOR, SLABMIZER ASSEMBLY		1
1	127084	MOTOR, 3 HP 3 PHASE 3490 PRM		1
2	127022	Weldment, Dust Head Fixed		1
3	F05010-132	Nut, M8 Lock		2
4	127023	Weldment, Dust Head Removable		1
5	127124	Bushing, Cutter Spacer		1
6	127020	Head, Cutter 5 Tooth 5" Dia		1
7	127143	Washer, Cutter / Sanding		2
8	127198	Bolt, M10x25 Button Head		1
9	127021	Insert, Cutter 15x15x2.5 - R150		5
10	127209	Bolt, Insert		5

6.11 Control Box

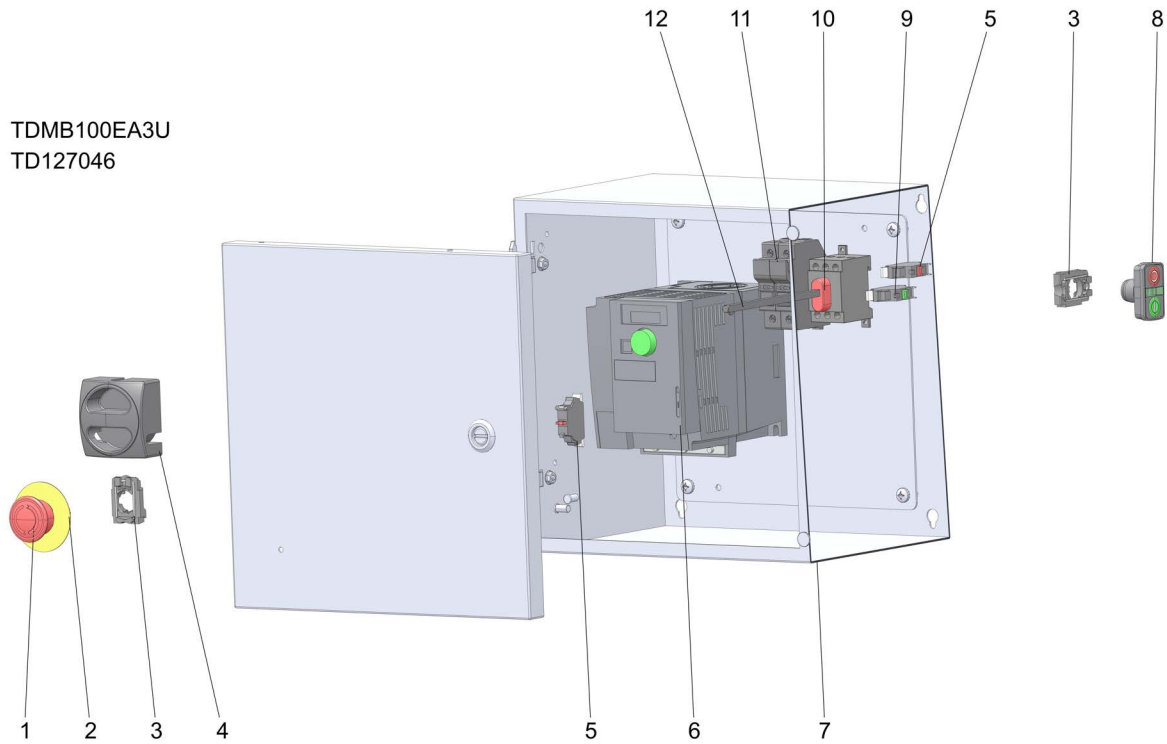

REF	PART #	DESCRIPTION	COMMENTS	QTY.
	127046	Assembly, MB100 Control Box		1
1	068940	Push-Button, Mshrm Mntnd Red TrnRI ZB5		1
2	050992	Legend, E-Stop, Round Yellow		1
3	068950	Collar, Mount 1NC ZB5		2
4	050883-1	Handle, Disconnect RED/YEL 6mm Shaft		1
5	068921	Switch Block, Contact NC ZB5		2
6	068429-A	AC Drive, ATV320 3HP 1Ph 240VAC		1
7	127011-	Assembly, Control Box Enclosure		1
8	068909	Push-Button, Grn/Red Flush Illuminated		1
9	068920	Contact Block, NO ZB5		1
10	050903-1	Disconnect, 40A 3Ph Non-Fused-6mm		1
11	052726	Fuse, 30A 600V Class CC Delay		1
12	051673-1	Shaft, Disconnect 180mmx6mm		1

6 Clamps (Hold Down Side Mount)

6.12 Clamps (Hold Down Side Mount)

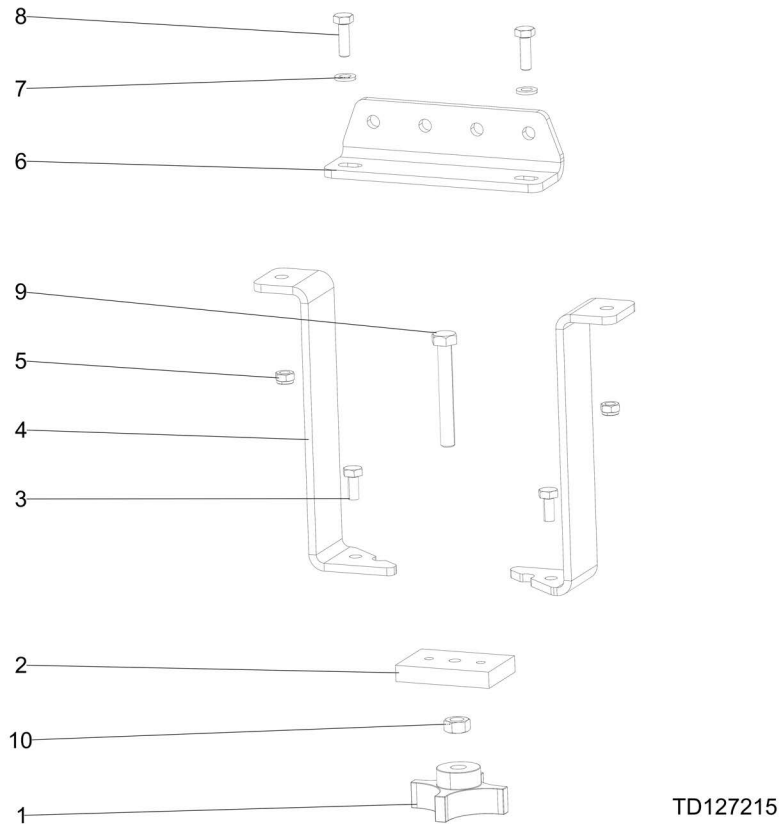

REF	PART #	DESCRIPTION	COMMENTS	QTY.
	127215	Assembly, Hold Down Side Mount		2
1	127263	Knob, Clamp Adjustment		1
2	127213	Block, Bottom Clamp		1
3	F05020-7	Bolt, M6-1 x 14 Class 8 HH		2
4	127214	Plate, Side Clamp		2
5	F05010-200	Nut, M6-1.0 Nylon Lock		2
6	127216	Angle, Top Clamp		1
7	F05026-1	Washer, M6 Flat Class 4		2
8	F05020-6	Bolt, M6-1x20 HH Class 8		2
9	F05021-15	Bolt, M8-1.25x60 HH Class 8.8		1
10	F05010-162	Nut, M8-1.25 Free Zinc Plate		1

6.13 Decal Kit

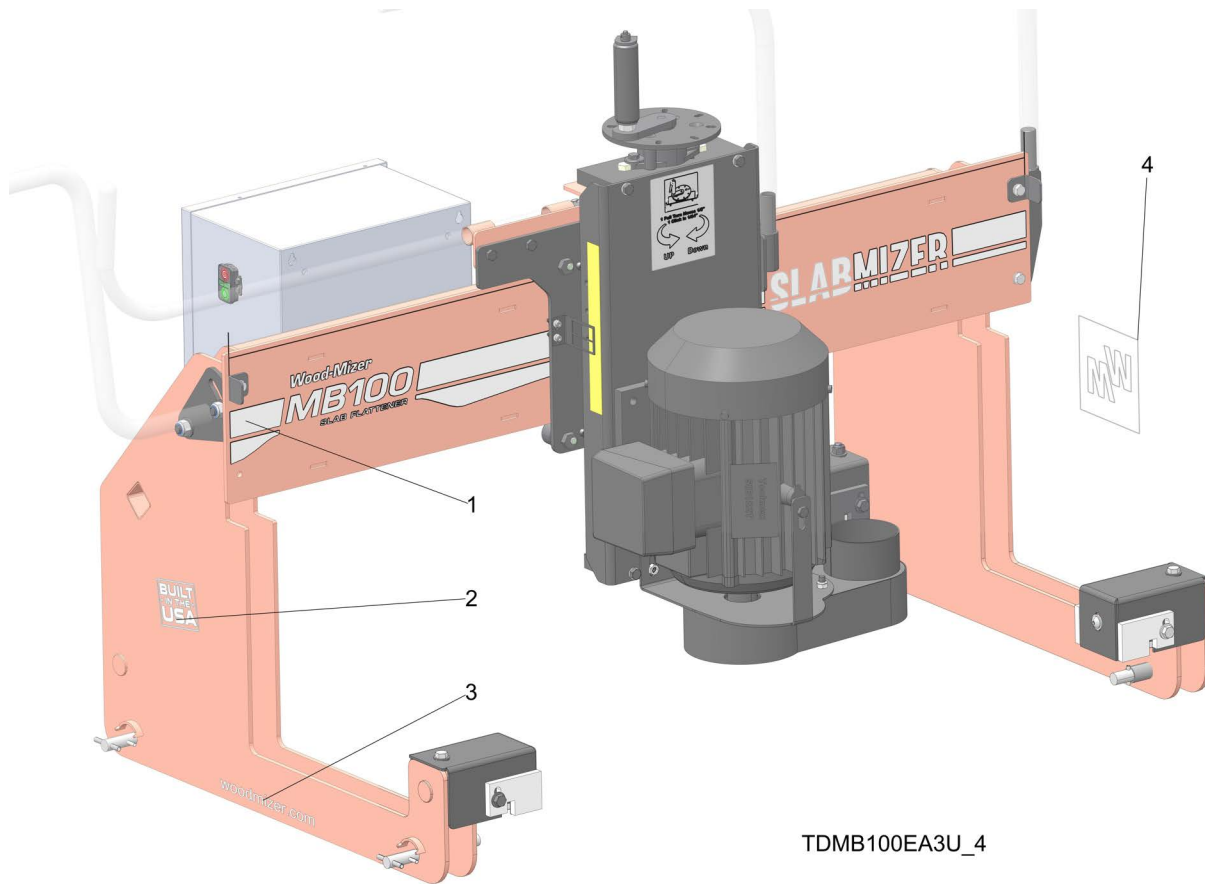

TDMB100EA3U_4

REF	PART #	DESCRIPTION	COMMENTS	QTY.
	133078	Decal Kit, MB100		1
1	133079	Decal, MB100 Large		1
2	074008	Decal, Built In The USA		1
3	107170	Part, New		1
4	110656	Decal, Large WM Badge		1

6.14 Sanding Head (Optional Accessory)

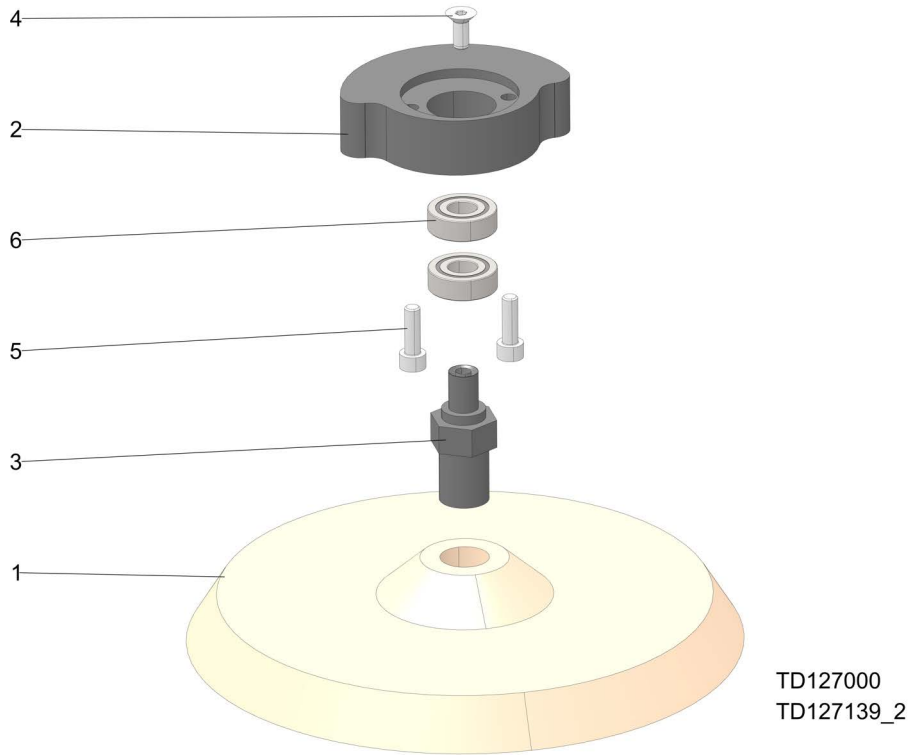

REF	PART #	DESCRIPTION	COMMENTS	QTY.
	127139	ASSEMBLY, SANDING HEAD		1
1	127140	Head, Sanding 7"		1
2	127141	Balance, Orbital		1
3	127142	Stud, Sanding		1
4	127199	Bolt, M5x10 Flat Head		1
5	127200	Bolt, M5x18 SH		2
6	P10688	Bearing, R6-2nsl		2
	127210	Sandpaper, 40 Grit		1
	127211	Sandpaper, 80 Grit		1
	127212	Sandpaper, 180 Grit		1

6.15 Bed Extension (Optional)

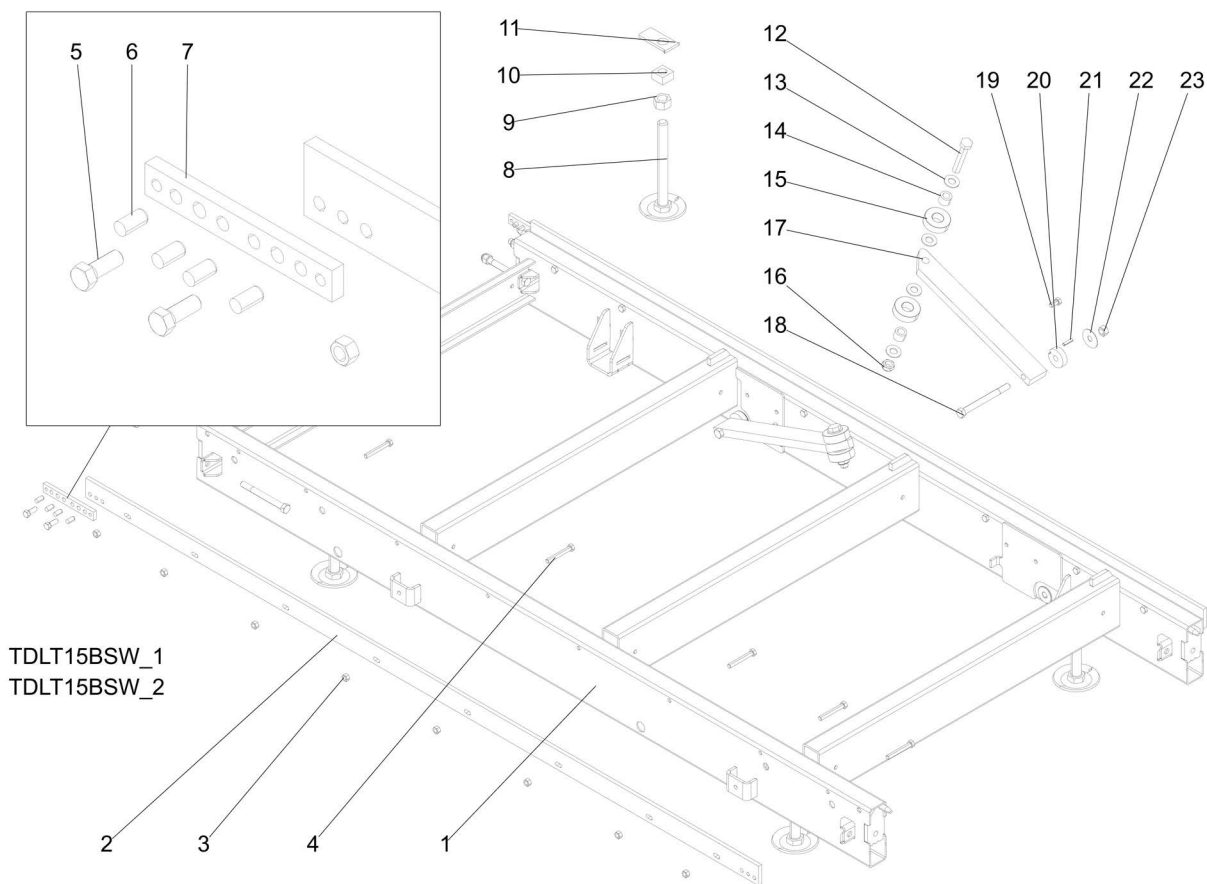

REF	PART #	DESCRIPTION	COMMENTS	QTY.
	LT15BSW	Bed Assembly, Lt15 - 6'8" Bed Ext, Wide		
1	110438	Wldmt, LT15 Wide Bed		1
2	016489	Rail, LT15 Bed 80 1/2		2
3	F05010-25	Nut, 3/8-16 Swaged		16
4	F05007-230	Bolt, 3/8-16x2 3/4 FT Gr5		16
5	F05007-87	Bolt, 3/8-16x1 Gr5 HH		4
	016170	Splice Assy, Pinned Bed Rail		2
6	F05012-74	Pin, 3/8 x 3/4 Dowel		4
7	016168	Splice, Pinned Bed Rail		1
8	046615	Outrigger Wldmt, LT15		4
9	F05010-136	Nut, 7/8-9 Free		4
10	F05010-186	Nut, 7/8-9 Square Zinc		4
11	110790	Plate, Outrigger Nut		4
	074276	Roller Assy, Side Support LT15		2
12	F05009-93	Bolt, 5/8-11x3 1/2 HH Gr 5		1
13	F05011-5	Washer, 5/8 SAE Flat		4

6*Bed Extension (Optional)*

REF	PART #	DESCRIPTION	COMMENTS	QTY.
14	016560	Bushing, Bronze 5/8x1x3/4		2
15	016561	Roller, Side Support		2
16	F05010-96	Nut, 5/8-11 Jam Nyl Lock		1
17	014855	Support, Log Side		2
18	F05008-28	Bolt, 1/2-13x5 1/2 Hex Head GR5 Zinc		2
19	F05007-168	Bolt, 3/8-16 x 3/4 HH Gr5 w/Nylon Patch		2
20	025767	Washer, 1/2", Log Side Support		2
21	F05012-7	Pin, 1/4 X 1 Roll		2
22	014972	Washer, 33/64x1 3/4x1/32 Nylon		2
23	F05010-3	Nut, 1/2-13 Swaged Hex		2
24	LT15BSW	Bed Assembly, LT15 - 6'8" Bed Ext, Wide		1

SECTION 7 TROUBLESHOOTING GUIDE



WARNING! Turn the key switch to the OFF (0) position and remove the key before performing service near moving parts such as cutters, pulleys, motors, belts, and chains. If the key is turned on and moving parts activated, serious injury or death may result.

PROBLEM	CAUSE	SOLUTION
Burning Wood	Dull or dirty knives	Turn cutter inserts to sharp edge or replace inserts
	Inappropriate feed rate	Adjust feed rate faster or slower.
Leaving Lines	Misaligned cutter head	Align the Cutter Head, Refer to Alignment in Section 8
	Step-over of cutter is too large	Decrease the step-over to reduce the presence of lines
Nothing Working	No Power, or Main disconnect switch is off	Check incoming Power, Turn disconnect switch "ON" on the the Control Box
Cutting Head Not Turning	Blown Motor Drive Fuses	Check motor drive for error indication. Reference ATV320 manual for error information or call customer support. Have a licensed Electrician inspect the fuses and power supply
Cross Feed Not Working	Dirt, Debris, Resin, Pitch Build up on rails and rollers	Make sure head moves smoothly by removing Debris, Pitch, Resin and Dirt Buildup on Rails, pulleys and rollers.
	Unsuccessful resolve of issue	Contact Customer Support

TABLE 7-0