

LT15 Trailer

Safety, Operation, Maintenance & Parts Manual

LT15TRG2

Rev. A1.00- A1.03



Safety is our #1 concern! Read and understand all safety information and instructions before operating, setting up or maintaining this machine.

November 2014

Form #2068

California
Proposition 65 Warning



WARNING: Breathing gas/diesel engine exhaust exposes you to chemicals known to the State of California to cause cancer and birth defects or other reproductive harm.

- Always start and operate the engine in a well-ventilated area.
- If in an enclosed area, vent the exhaust to the outside.
- Do not modify or tamper with the exhaust system.
- Do not idle the engine except as necessary.

For more information go to **www.P65warnings.ca.gov**.



WARNING: Drilling, sawing, sanding or machining wood products can expose you to wood dust, a substance known to the State of California to cause cancer. Avoid inhaling wood dust or use a dust mask or other safeguards for personal protection.

For more information go to **www.P65Warnings.ca.gov/wood**.

Active Patents assigned to Wood-Mizer, LLC

Wood-Mizer, LLC has received patents that protect our inventions which are a result of a dedication to research, innovation, development, and design. Learn more at: woodmizer.com/patents

©2022 Wood-Mizer LLC

Printed in the United States of America, all rights reserved. No part of this manual may be reproduced in any form by any photographic, electronic, mechanical or other means or used in any information storage and retrieval system without written permission from

Wood-Mizer, LLC
8180 West 10th Street
Indianapolis, Indiana 46214

Table of Contents

Section-Page

SECTION 1	TIRE SAFETY	1-1
1.1	Tire labeling.....	1-1
1.2	Recommended tire inflation pressure.....	1-2
1.3	Glossary.....	1-5
1.4	Tire care, maintenance, and safety practices.....	1-7
1.5	Vehicle load limits.....	1-8
SECTION 1	TRAILER ASSEMBLY	1-1
1.1	Required Tools.....	1-1
1.2	Uncrating the Trailer.....	1-1
1.3	Trailer Parts List.....	1-2
1.4	Installation.....	1-4
1.5	Tongue Frame & Rear Light Bar Installation.....	1-8
1.6	Up/Down Handle Conversion.....	1-12
1.7	Final Installation.....	1-16
1.8	Travel Position Hole.....	1-18
1.9	Winch Installation (Optional).....	1-19
SECTION 2	TRAILER OPERATION	2-1
2.1	Preparing The Sawmill For Travel.....	2-1
2.2	Preparing The Sawmill For Operation.....	2-4
2.3	Loading A Log using Optional Ramps and Winch.....	2-7
SECTION 3	MAINTENANCE	3-1
SECTION 4	REPLACEMENT PARTS	4-1
4.1	Trailer (Complete).....	4-1
4.2	Front Trailer Parts.....	4-2
4.3	Rear Trailer Parts.....	4-4
4.4	Adjustable Jack Assembly.....	4-5
4.5	Axle/Fender & Middle Trailer Parts.....	4-6
4.6	Saw Head Rest Pin/Bracket Parts.....	4-8
4.7	Up/Down Guard Parts.....	4-9
4.8	Winch & Log Ramps Parts (Optional).....	4-10

SECTION 1 TIRE SAFETY

1.1 Tire labeling

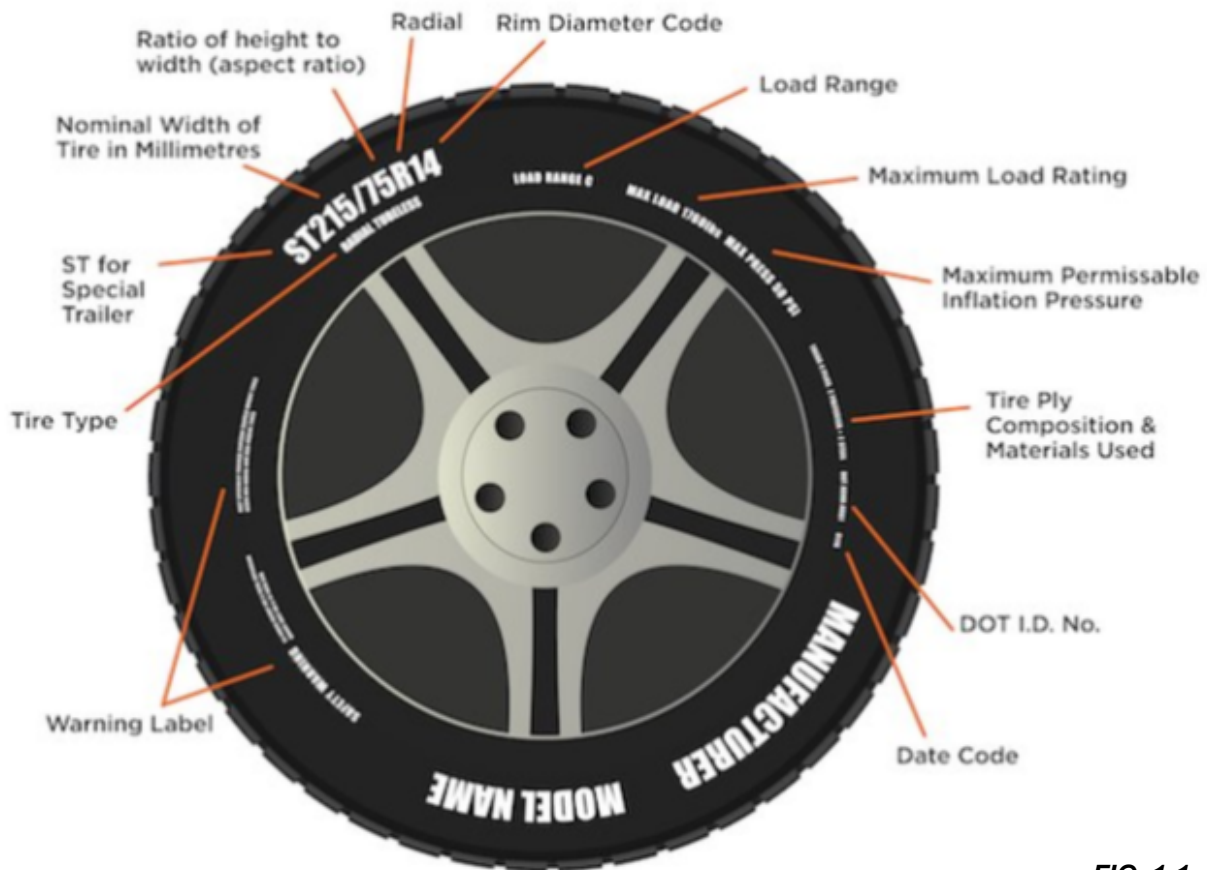

FIG. 1-1

Tire markings

TIRE CLASS AND SIZE: (Example: ST215/75R14)

- **ST** stands for Special Trailer tire. ST trailer tires are built to tow heavy loads, withstand excessive heat, and reduce sway.
- **215** is tire width in millimeters;
- **75** is the aspect ratio, or ratio of height to width;
- **R** is type of construction (radial, in the example)
- **14** is rim diameter in inches.

TIRE TYPE Below the tire size is either 'radial' or 'bias.' Radial tires (or 'radial-ply tires') are constructed with polyester and/or nylon plies that run across the tire perpendicularly, and sometimes include steel belts that run under the tread. Bias-ply tires Bias-ply cords layer in a criss-cross pattern from sidewall to sidewall, and they are also sometimes reinforced with a steel belt.

LOAD RANGE Load range indicates the type of load a tire is designed to support at a specific inflation pressure. Trailer tires typically have C, D, or E load ranges. A load range 'C' tire, for example, is at its peak load capacity—possibly 1600 pounds—when it's inflated to its maximum pressure of 50 PSI. A load range 'C' tire at 25 PSI might be able to support a load of 990 pounds, while at 40 PSI, that capacity could be 1300 pounds.

MAXIMUM LOAD RATING Load rating or load index indicates the weight a tire can safely carry at its maximum air pressure. In the example, at its maximum air pressure of 50 PSI (cold), a load range 'C' tire might have a load rating of 1760 pounds.

MAXIMUM PRESSURE Maximum pressure (when the tires are cold) needed for the tires to carry the maximum load; measured in PSI.

Identifying tires

Tires are required to have a Tire Identification Number (TIN) begin with the letters "DOT," followed by eight to thirteen characters that can be used to identify the manufacturing location, tire size, and manufacturer's specifications, along with the week and year the tire was manufactured. DOT Tire Identification Numbers are commonly but erroneously referred to as the tire's serial number, but it actually identifies production *batches*, not individual items.

Regulations also require the entire DOT Tire Identification Number to be branded on one sidewall, while only the letters "DOT" and the first digits of the Tire Identification Number must be branded onto the opposite sidewall. Therefore it is possible to see a Tire Identification Number that appears incomplete, yet simply requires looking at the tire's other sidewall to find the complete Tire Identification Number.

Tire Identification Number

DOT AND DATE CODES Department of Transportation identifier will include 10-12 numbers following 'DOT.' The first six to eight numbers indicate the manufacturer's code, where the tire was manufactured and the tire size.

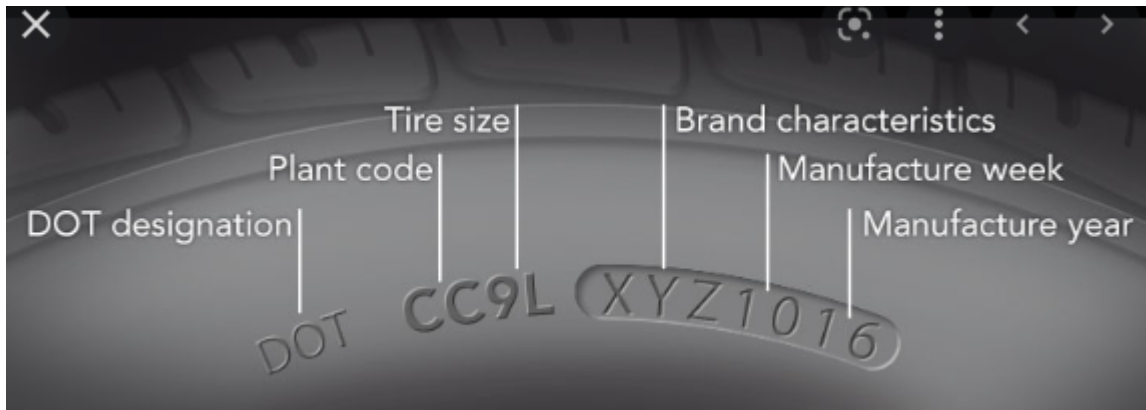

FIG. 1-2

1.2 Recommended tire inflation pressure

Recommended cold tire inflation pressure

The cold inflation pressure is the contained air pressure of a tire that would occur at an indexed temperature of 68°F or 20°C. This indexed temperature is based on the ideal ambient operating conditions for the tire.

TABLE 1-1 AMBIENT AIR TEMPERATURE PRESSURE ADJUSTMENT

Listed Pressure at 68°F (20°C)		10 psi	20 psi	30 psi	40 psi	50 psi	60 psi	70 psi	80 psi	90 psi	100 psi
104°F	40°C	11.7 psi	22.4 psi	33.1 psi	43.7 psi	54.4 psi	65.1 psi	75.8 psi	86.5 psi	97.1 psi	107.8 psi
86°F	30°C	10.8 psi	21.2 psi	31.5 psi	41.9 psi	52.2 psi	62.5 psi	72.9 psi	83.2 psi	93.6 psi	103.9 psi
68°F	20°C	10.0 psi	20.0 psi	30.0 psi	40.0 psi	50.0 psi	60.0 psi	70.0 psi	80.0 psi	90.0 psi	100.0 psi
50°F	10°C	9.2 psi	18.8 psi	28.5 psi	38.1 psi	47.8 psi	57.5 psi	67.1 psi	76.8 psi	86.4 psi	96.1 psi
32°F	0°C	8.3 psi	17.6 psi	26.9 psi	36.3 psi	45.6 psi	54.9 psi	64.2 psi	73.5 psi	82.9 psi	92.2 psi
14°F	-10°C	7.5 psi	16.4 psi	25.4 psi	34.4 psi	43.4 psi	52.4 psi	61.3 psi	70.3 psi	79.3 psi	88.3 psi
-4°F	-20°C	6.6 psi	15.3 psi	23.9 psi	32.5 psi	41.2 psi	49.8 psi	58.4 psi	67.1 psi	75.7 psi	84.3 psi
-22°F	-30°C	5.8 psi	14.1 psi	22.4 psi	30.7 psi	39.0 psi	47.3 psi	55.5 psi	63.8 psi	72.1 psi	80.4 psi
-40°F	-40°C	4.9 psi	12.9 psi	20.8 psi	28.8 psi	36.8 psi	44.7 psi	52.7 psi	60.6 psi	68.6 psi	76.5 psi

1 **Tire Safety**
The vehicle tire inflation pressure label and location

Listed Pressure at 68°F (20°C)		69 kPa	138 kPa	207 kPa	276 kPa	345 kPa	414 kPa	483 kPa	551 kPa	620 kPa	689 kPa
104°F	40°C	81 kPa	154 kPa	228 kPa	301 kPa	375 kPa	449 kPa	522 kPa	596 kPa	670 kPa	743 kPa
86°F	30°C	75 kPa	146 kPa	217 kPa	289 kPa	360 kPa	431 kPa	502 kPa	574 kPa	645 kPa	716 kPa
68°F	20°C	69 kPa	138 kPa	207 kPa	276 kPa	345 kPa	414 kPa	483 kPa	551 kPa	620 kPa	689 kPa
50°F	10°C	63 kPa	130 kPa	196 kPa	263 kPa	329 kPa	396 kPa	463 kPa	529 kPa	596 kPa	662 kPa
32°F	0°C	57 kPa	122 kPa	186 kPa	250 kPa	314 kPa	378 kPa	443 kPa	507 kPa	571 kPa	635 kPa
14°F	-10°C	52 kPa	113 kPa	175 kPa	237 kPa	299 kPa	361 kPa	423 kPa	485 kPa	546 kPa	608 kPa
-4°F	-20°C	46 kPa	105 kPa	165 kPa	224 kPa	284 kPa	343 kPa	403 kPa	462 kPa	522 kPa	581 kPa
-22°F	-30°C	40 kPa	97 kPa	154 kPa	211 kPa	269 kPa	326 kPa	383 kPa	440 kPa	497 kPa	554 kPa
-40°F	-40°C	34 kPa	89 kPa	144 kPa	199 kPa	253 kPa	308 kPa	363 kPa	418 kPa	473 kPa	527 kPa

The vehicle tire inflation pressure label and location

The generic bilingual tire pressure label appears as in FIG. 1-3. The label on the vehicle has information specific to the trailer filled in

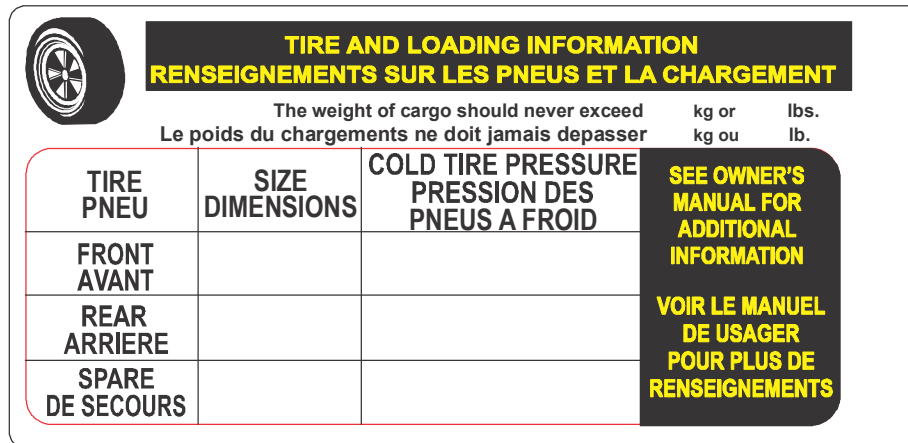

FIG. 1-3

The label is placed near the VIN placard, toward the **front left side** of the trailer.

General area of VIN placard and tire pressure label for Wood-Mizer mill trailers.



FIG. 1-4

Consequences of tire under-inflation

Underinflated tires and overloaded vehicles are a major cause of tire failure. Tire inflation effects a vehicle's

- steering,
- stopping,
- traction, and
- load-carrying capability.

To avoid flat tires and other types of tire failure, you should

- maintain proper tire pressure,
- observe tire and vehicle load limits,
- avoid road hazards, and
- regularly inspect your tires.

Proper inflation

CHECK TIRE PRESSURE

Use a tire pressure gauge, which you can be purchased at most service stations or auto parts stores. Check the pressure when the tires are **COLD**, as the friction from driving affects the pressure. If driven recently, wait at least three hours for the tires to cool down.



COMMON TIRE PRESSURE GAUGES

FIG. 1-5

1. Remove the cap from the air valve on the tire, and put it somewhere you won't lose it.
2. Press the tire gauge against the open valve stem momentarily.
3. Read the air pressure gauge.
4. Compare this number with the recommended tire pressure.

5. Inflate/release air as needed.
6. Replace the tire's air valve cap.
7. Repeat this process for each tire.

INFLATE YOUR TRAILER'S TIRES

1. Park close enough to the air compressor so you can reach all tires with the hose.
2. If the valve caps are still on, remove them.
3. Press the hose nozzle down on the valve stem.

NOTE: You should notice the tire inflating and feel air flowing through the hose. If not, check to ensure the hose is securely placed on the valve stem.

4. Remove the hose fitting.
5. Check the air pressure as described above.
6. Repeat steps 3- 5 as needed until the tire is inflated to the correct psi.
7. Repeats steps 2-5 for the vehicle's other tires.
8. Once the tires are inflated properly, replace the valve caps.

RELEASE AIR FROM TIRES

Overinflated tires can lead to poor handling, such as skidding and hydroplaning.

1. Briefly press the small dot or bead on the back of the tire pressure gauge into the center of the valve stem on the tire.

NOTE: You should hear the air escaping the tire.

2. Use the gauge to check the tire pressure.
3. Repeat these steps until you've released enough air to reach the correct psi.

WHEN TO CHECK TIRE PRESSURE

Use Table 1-1 to adjust the recommended cold tire pressure to the ambient temperature. Check tire pressure monthly.

- Most tires may naturally lose air over time.
- Tires can lose air suddenly if you drive over a pothole or other object or if you strike the curb when parking.
- With radial tires, it is usually not possible to determine underinflation by visual inspection.

1.3 Glossary

ALPHA CHARACTER A single alphabetical character from A to Z.

BEAD SEPARATION A breakdown of bond between components in the bead area.

BEAD That part of the tire made of steel wires, wrapped or reinforced by ply cords, that is shaped to fit the rim.

CARCASS PLY A ply that extends to the beads.

CARCASS The tire structure, except tread and sidewall rubber.

CHUNKING The breaking away of pieces of the tread or sidewall.

COLD TIRE PRESSURE The air pressure in a tire at ambient temperature, **not having been driven for the at least 3 hours.**

CORD SEPARATION Cord parting away from adjacent rubber compounds.

CORD The strands that form the plies in the tire.

CRACKING Any parting within the tread, sidewall, or innerliner of the tire extending to cord material.

CURB WEIGHT The weight of a motor vehicle with standard equipment including the maximum capacity of fuel, oil, and coolant, and, if so equipped, air conditioning and additional weight of optional engine.

DEEP TREAD RADIAL A deep tread radial tire is one having a minimum tread depth of 14.3 mm (18/32 inch or 0.5625 inch) or greater.

DOT SYMBOL The letters "DOT" are part of the DOT serial number. This is the manufacturer's certification that the tire or rim meets or exceeds the requirements of FMVSS Nos. 110 and 139.

DOT TIRE IDENTIFICATION NUMBER Number appearing on the sidewall of the tire near the rim required by 49 CFR Part 574.5 which identifies the manufacturer's identification mark, tire size, tire type code and date of manufacture. See Fig. 1-2.

EXTRA LOAD TIRE A tire designed to operate at higher loads and at higher inflation pressures than the corresponding standard tire.

FIELDS Any group of letters and numbers that have significance or meaning.

GAWR The Gross Axle Weight Rating (GAWR) means the value specified by the vehicle manufacturer as the load-carrying capacity of a single axle system, as measured at the tire-ground interfaces.

GROOVE The space between two adjacent tread ribs.

GVWR The Gross Vehicle Weight Rating (GVWR) means the value specified by the manufacturer as the loaded weight of a single vehicle.

INNERLINER SEPARATION The parting of the innerliner from cord material in the carcass.

INNERLINER The layer(s) forming the inside surface of a tubeless tire that contains the inflating medium within the tire.

INTENDED OUTBOARD SIDEWALL (1) The sidewall that contains a whitewall, bears white lettering or bears manufacturer, brand, and/or model name molding that is higher or deeper than the same molding on the other sidewall of the tire; or (2) The outward facing sidewall of an asymmetrical tire having a particular side that must always face outward when mounted on a vehicle.

LIGHT VEHICLE TIRE A new, pneumatic, radial tire intended for use on motor vehicles (other than motorcycles and low speed vehicles) that have a gross vehicle weight rating (GVWR) of 10,000 pounds or less and were manufactured after 1975.

LOAD RATING The maximum load a tire is rated to carry for a given inflation pressure.

MAXIMUM LOAD RATING The load rating at the maximum permissible inflation pressure for that tire.

MAXIMUM INFLATION PRESSURE The maximum cold inflation pressure needed for your tire to support the weight of its *maximum load-carrying capacity*.

MEASURING RIM The rim on which a tire is fitted for physical dimension requirements.

NHTSA/OVSC National Highway Traffic Safety Administration, Office of Vehicle Safety Compliance (Canada).

OPEN SPLICE Any parting at any junction of tread, sidewalls, or innerliner that extends to cord material.

OUTER DIAMETER The overall diameter of an inflated new tire.

OVERALL WIDTH The linear distance between the exteriors of the sidewalls of an inflated tire, including elevations due to marking, decorations, or protective bands or ribs.

PLY A layer of rubber-coated parallel cords.

PLY SEPARATION A parting or rubber compound between adjacent plies.

PNEUMATIC TIRE A mechanical device made of rubber, chemicals, fabric, steel, or other materials, which, when mounted on an automotive wheel, provides the traction and contains the gas or fluid that sustains the load.

RADIAL PLY TIRE A pneumatic tire in which the ply cords that extend to the beads are laid at substantially 90° to the centerline of the tread.

RECOMMENDED INFLATION PRESSURE The cold inflation pressure provided on the Tire Information label and on the VIN tag.

REINFORCED TIRE A tire designed to operate at higher loads and at higher inflation pressures than the corresponding standard tire.

RESPONSIVE TEST A special test initiated through a complaint, field inspection, failed standard test, or COTR discretion. **RIM** A metal support for a tire or a tire and tube assembly upon which the tire beads are seated.

RIM DIAMETER Nominal diameter of the bead seat.

RIM SIZE DESIGNATION Rim diameter and width.

RIM TYPE DESIGNATION The industry or manufacturer's designation for a rim by style or code. **RIM WIDTH** Nominal distance between rim flanges.

SECTION WIDTH The linear distance between the exteriors of an inflated tire's sidewalls, excluding elevations due to marking, decoration, or protective bands.

SIDEWALL That portion of a tire between the tread and the bead.

SIDEWALL SEPARATION The parting of the rubber compound from the cord material in the sidewall.

SIZE FACTOR The sum of the section width and the outer diameter of a tire determined on the test rim.

SNOW TIRE A snow tire means a tire that attains a traction index equal to or greater than 110, compared to the ASTM E-1136 Standard Reference Test Tire, when using the snow traction test as described in ASTM F-1805-00, Standard Test Method for Single Wheel Driving Traction in a Straight Line on Snow- and Ice-Covered Surfaces, and which is marked with an Alpine Symbol specified in S5.5(i) of FMVSS No. 139 on at least one sidewall.

TREAD That portion of a tire that comes into contact with the road.

TREAD RIB A tread section running circumferentially around a tire.

TREAD SEPARATION Pulling away of the tread from the tire carcass.

TREADWEAR INDICATORS (TWI) Projections within the principal grooves designed to give a visual indication of the degree of wear of the tread.

UVW The Unloaded Vehicle Weight (UVW) is the weight of a vehicle with maximum capacity of all fluids necessary for vehicle operation, but without cargo, occupants, or accessories that are ordinarily removed from the vehicle when they are not in use.

VEHICLE NORMAL LOAD ON THE TIRE The vehicle normal load on the tire means that load on an individual tire that is determined by distributing to each axle its share of the curb weight, accessory weight, and normal occupant weight and dividing by 2.

1.4 Tire care, maintenance, and safety practices

1. Check your cold tire pressure at least once a month (See [Proper inflation](#))
2. Visually inspect your tires
 - 1). Check the tread at least once a month for excessive or uneven wear.
 - 2). Measure tread depth in three locations across the tire's tread: (1) outer edge, (2) center, and (3) inside edge.

NOTE: Accurate tread depth measurements are made with a simple tread depth gauge available at any parts store. --Or you can use the quarter (coin) method.

Insert a quarter into a tread groove with the top of Washington's head facing down.

If the top of his head is not visible, your tires have at least 4/32" of tread and are fine for continued use. If you can see above the top of Washington's head, replace the tire.

- 3). Inspect for over inflation: wear primarily in the center of the tread, with less wear at the tire's edges.
- 4). Inspect for under inflation: wear primarily on both edges of the tire tread, with less wear in the center.
- 5). Inspect for tread wear on one edge of the tire which occurs when the wheels are out of alignment.
- 6). Inspect for erratic tread wear, "cupping," caused by the wheel out of balance, or suspension components need to be replaced.

7). Inspect for raised portion of the tread or sidewall which may indicate that one of the belts in the tire carcass has separated from those next to it.

3. Have your alignment checked every year.
4. Check and correct your tire balance.

1.5 Vehicle load limits

NOTICE Wood-Mizer trailers are not intended to carry any occupants or cargo.

SECTION 1 TRAILER ASSEMBLY



IMPORTANT! The trailer option is intended for use with LT15 sawmills Rev. E4.00 (LT15BS bed section Rev. E.00) and newer with three bed sections. LT15 sawmills prior to Rev. E6.08 require modification to the mast to allow repositioning of the up/down system ([See Section 1.6](#)).

1.1 Required Tools

- Wrench sizes 3/4 in, 9/16 in, 7/16 in. (Two wrenches or a combination of a wrench and a socket with a ratchet may be required)
- Fish tape (20 ft minimum)
- Rubber mallet (for uncrating or aligning heavy assemblies)
- Lifting equipment

1.2 Uncrating the Trailer

The LT15 trailer is bolted to the shipping crate with lag screws and shipping brackets as shown in Fig. 1-1. Unbolt these sections for assembly. Smaller assemblies are shipped in the boxes.

See Figure 1-1.

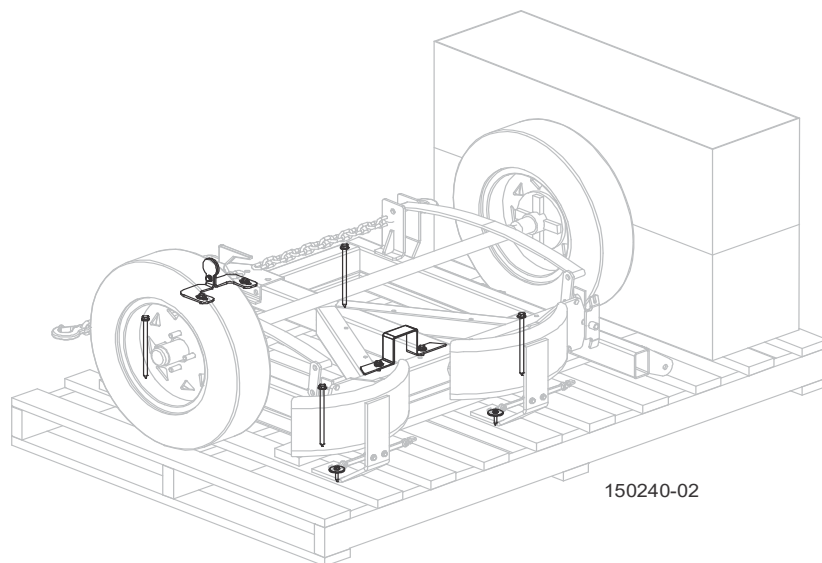

FIG. 1-1

1.3 Trailer Parts List

The following parts are supplied with the trailer. For easier installation, lay the parts out in a general configuration as when installed.

NOTE: See the replacement parts section for a full list of components, part numbers and installation location.

- Trailer Assemblies and Weldments:

See Figure 1-2.

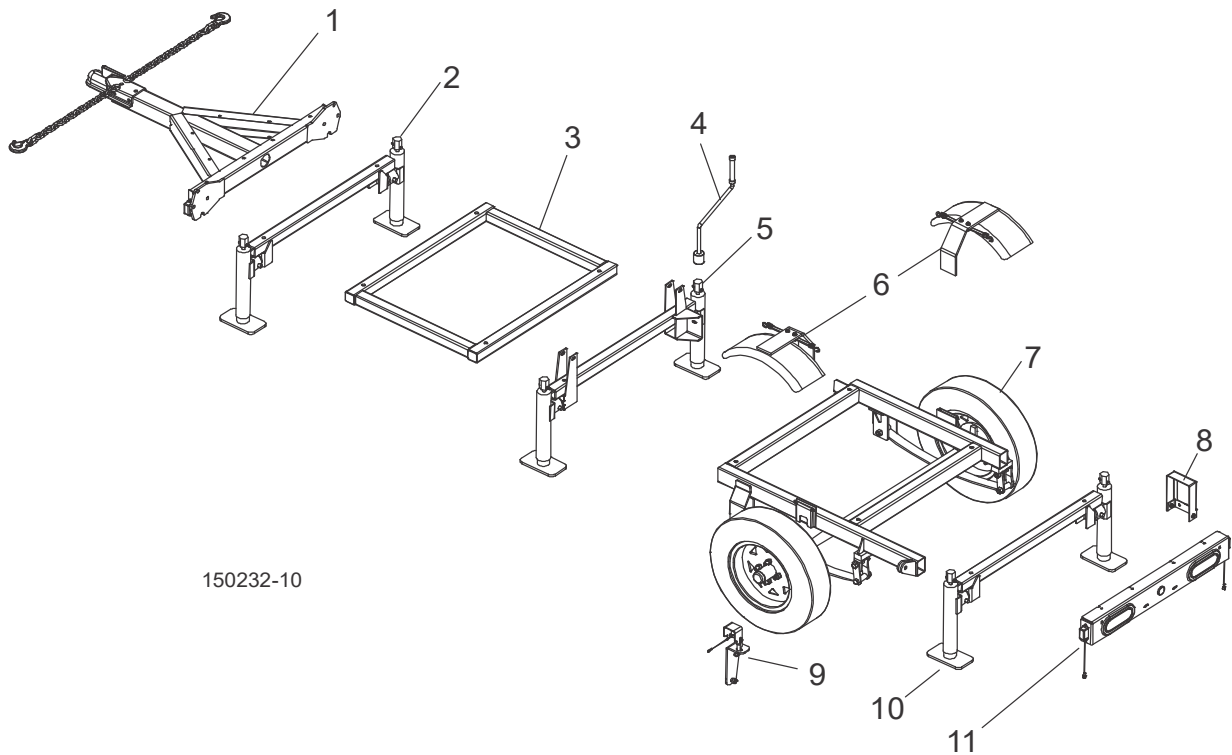

FIG. 1-2

- | | |
|------------------------------|-------------------------------|
| 1. Tongue | 7. Axle |
| 2. Front Jack (same as rear) | 8. Up/Down Guard |
| 3. Brace Weldment | 9. Head Rest |
| 4. Jack Crank Handle | 10. Rear Jack (same as front) |
| 5. Center Jack | 11. Rear Light Bar |
| 6. Fenders | |

1 Trailer Assembly

Trailer Parts List

■ Bolts (*size not to scale*):

NOTE: Kits will include bolts of both sizes to fit LT15 beds prior to revision E8.12 and after this revision. **There will be bolts left over after installation.**

(2) 1/4-20 x 3/4" Full Thread Hex Head



(1) 1/4-20 x 2 3/4" Hex Head



(1) 3/8-16 x 3/4" Hex Head



(2) 3/8-16 x 3" Hex Head



(2) 3/8-16 x 5" Carriage

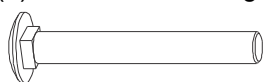

(1) 1/2-13 x 1 1/2" Hex Head



(1) 1/2-13 x 3 1/2" Full Hex Head

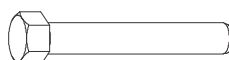

(11) 1/2-13 x 3 1/2" Hex Head



Bed to jack frames for rev E8.12 and later

(8) 1/2-13 x 5 1/2" Hex Head



Bed to jack frames for rev E8.11 and prior

(4) 1/2-13 x 4 1/2" Hex Head



Bed to axle frames for rev E8.12 and later

(4) 1/2-13 x 6 1/2" Hex Head



Bed to axle frames for rev E8.11 and prior

■ Nuts (*size not to scale*):

(1) 1/2-13 Swaged Hex



(1) 3/8-16 Keps



(16) 1/2-13 Hex Nylon Lock



(1) 1/2-13 Free Hex



(4) 3/8-16 Hex Nylon Lock



(2) 1/4-20 Nylon Lock



- Washers (*size not to scale*):

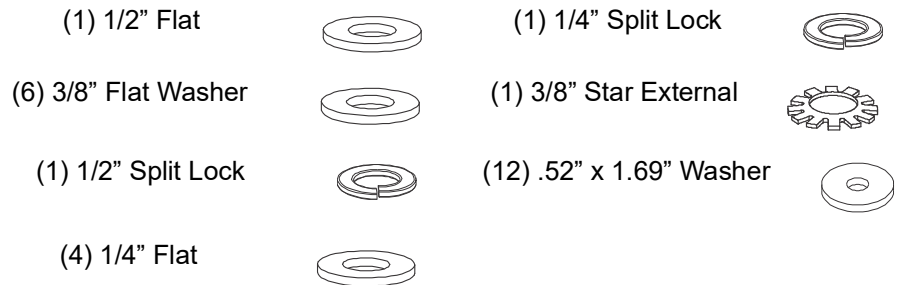

- Decals and Reflectors:



- (12) Clamp Bushings

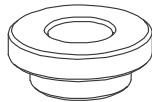

- (1) 3/64 x 6" Lanyard (part of head rest assembly)



- (2) Spacer Tube (part of rear light bar assembly)



- (1) Trailer Manual (not shown)

1.4 Installation

If you are adding the LT15GO2 trailer option to an assembled LT15 sawmill, follow the steps below to install the trailer to the sawmill bed. If you are adding the LT15GO2 trailer option to a new unassembled LT15 sawmill, first assemble the sawmill bed as instructed in the LT15 operator's manual, then follow the steps below to install the trailer to the sawmill bed. Be sure to use adequate manpower and lifting equipment to safely lift and stabilize the sawmill during installation.

1

Trailer Assembly

Installation

5. If the saw head is installed to the sawmill bed, disassemble the feed rope from the front rope bracket and remove from the feed crank pulley. Remove the rear feed rope bracket from the sawmill. Move the saw head to the rear end of the bed and support with lifting equipment such as a forklift or hoist. Remove the saw head from the bed and set aside.



WARNING: Use adequate lifting equipment to remove the saw head to the sawmill. Failure to do so may result in death or serious injury.

6. Using adequate lifting equipment, lift the sawmill bed off the ground. Remove the legs.

See Figure 1-3.

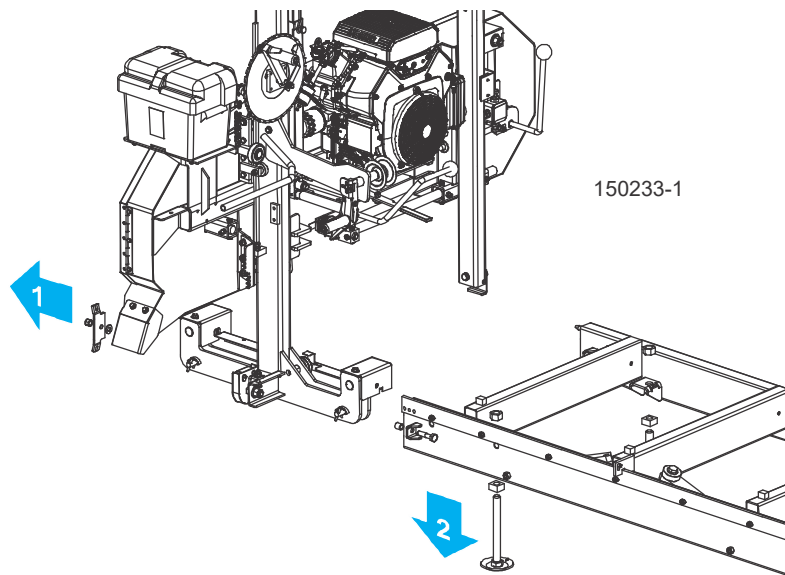
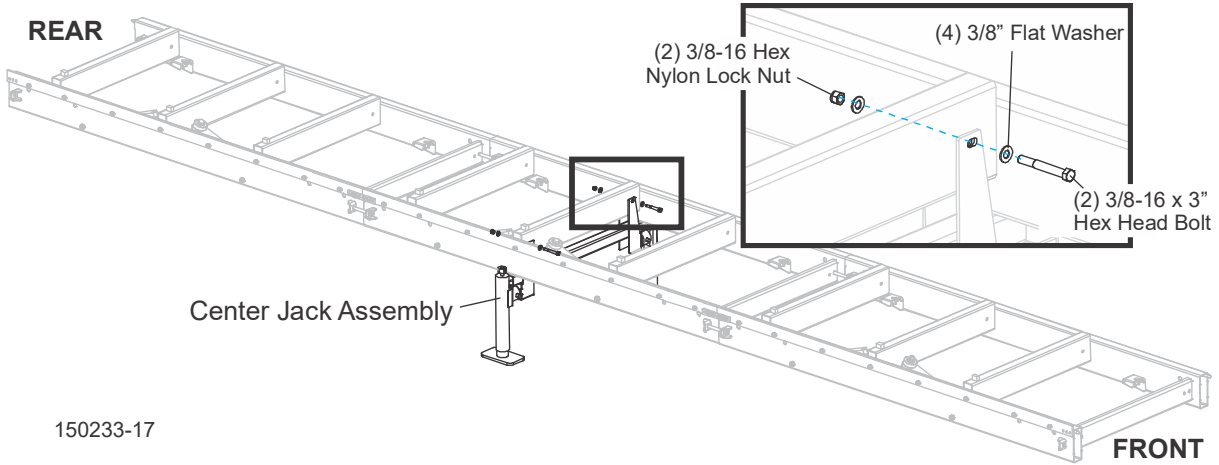

FIG. 1-3

7. Assemble the center jack assembly to the middle bed section and secure with the provided hex head bolts, washers and nuts as shown below. **NOTE:** It can be necessary to drill holes in the middle bed section for some LT15 models.

See Figure 1-4.



150233-17

FIG. 1-4

- Assemble the axle assembly to the middle bed section. Chock both tires to prevent rolling. Secure the axle assembly to the sawmill bed with the provided hex head bolts, bushings, washers and nuts as shown below.

See Figure 1-5.

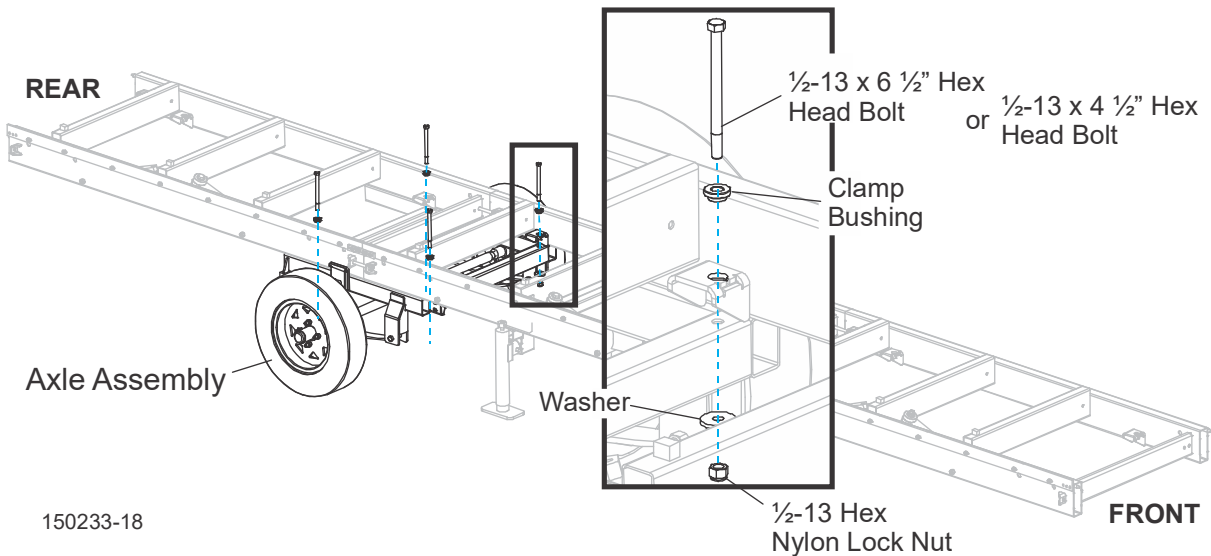

150233-18

FIG. 1-5

- Install the rear jack assembly to the rear bed section. Secure the jack assembly to the bed frame with the provided hex head bolts, bushings, washers and hex nylon lock nuts.

1 Trailer Assembly Installation

See Figure 1-6.

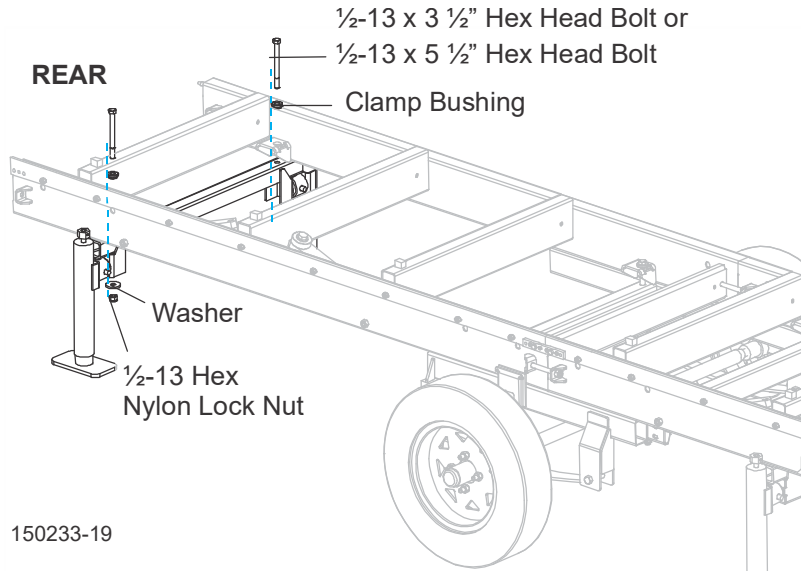

FIG. 1-6

10. Install the trailer brace weldment to the front end of the middle bed section. Use the provided hex head bolts, bushings, washers and hex nylon lock nuts to secure in place.

See Figure 1-7.

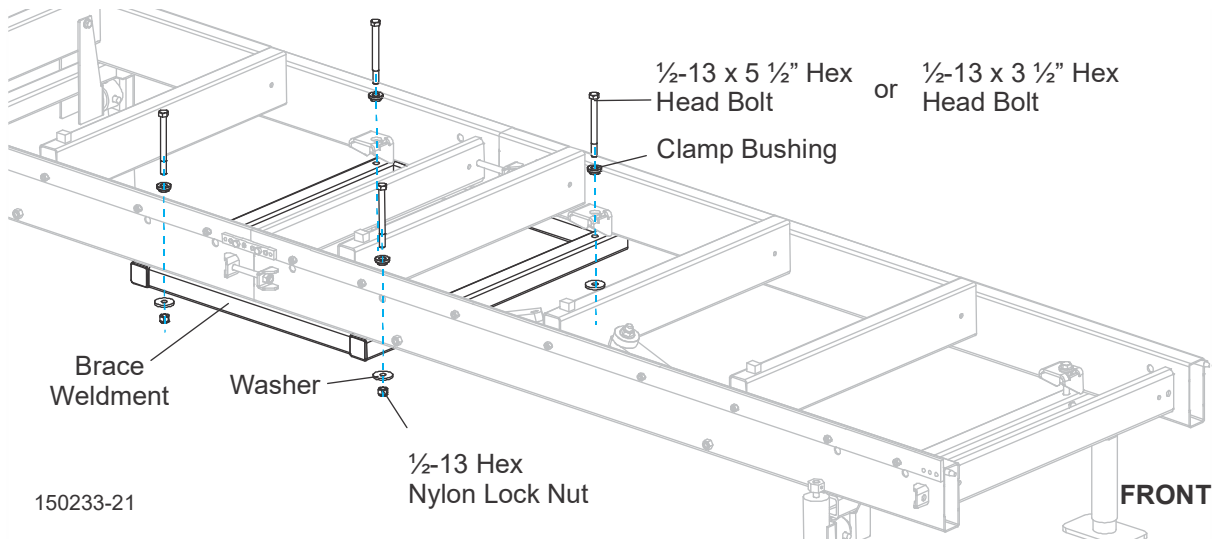

FIG. 1-7

11. Install the front jack assembly to the front bed section. Secure the jack assembly to the bed frame with the provided hex head bolts, bushings, washers and hex nylon lock nuts.

See Figure 1-8.

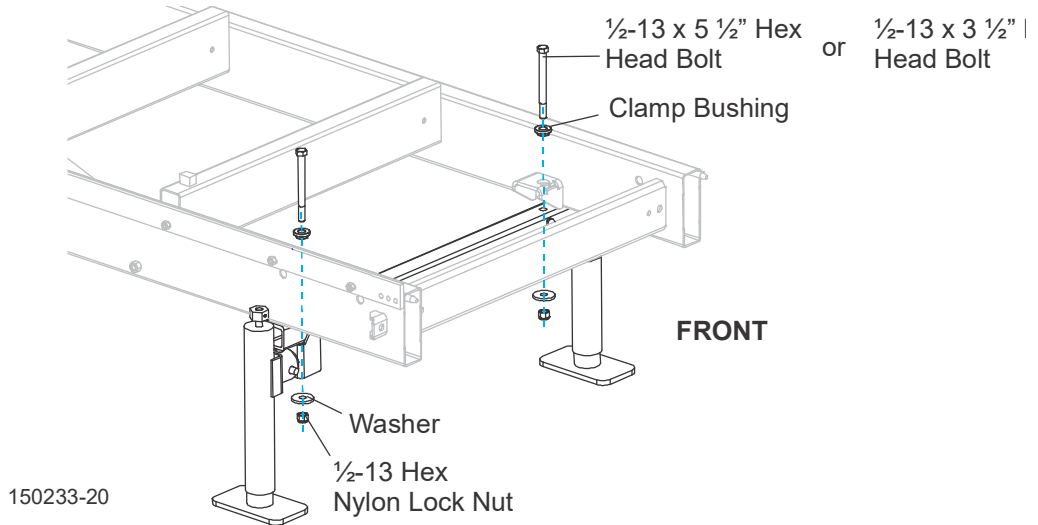

FIG. 1-8



WARNING: Use adequate lifting equipment to replace the saw head to the sawmill. Failure to do so may result in death or serious injury.

12. Assemble the saw head to the sawmill.
13. Replace the rear feed rope bracket. Leave the feed rope disassembled until trailer installation is complete.

1.5 Tongue Frame & Rear Light Bar Installation

Perform the following steps to install the rear light bar and the tongue frame to the trailer.

1

Trailer Assembly

Tongue Frame & Rear Light Bar Installation

Install the light bar

1. Install the light bar to the sawmill bed as shown below. Align the notches in the light bar with the sawmill bed rails.

See Figure 1-9.

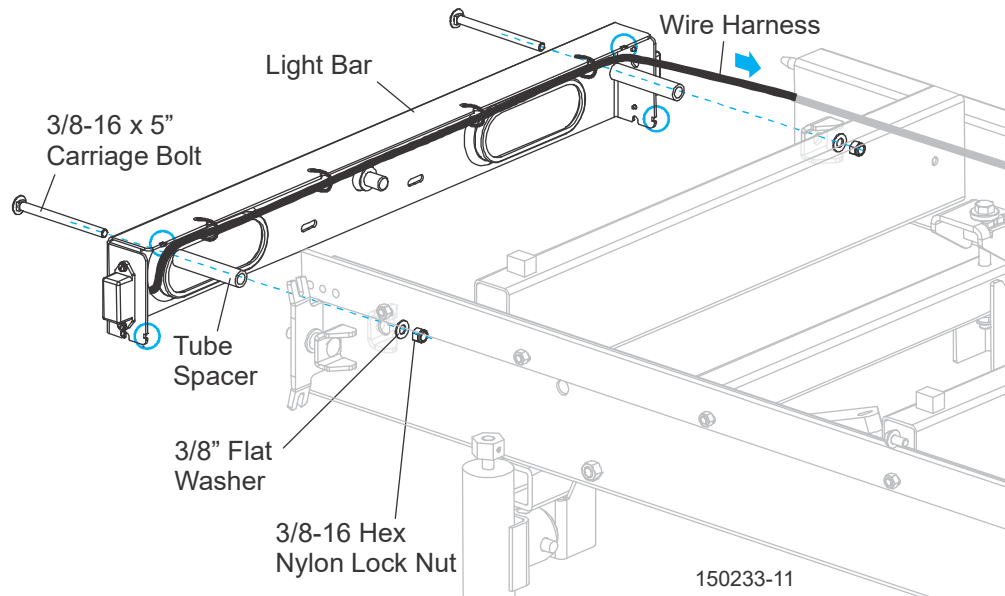
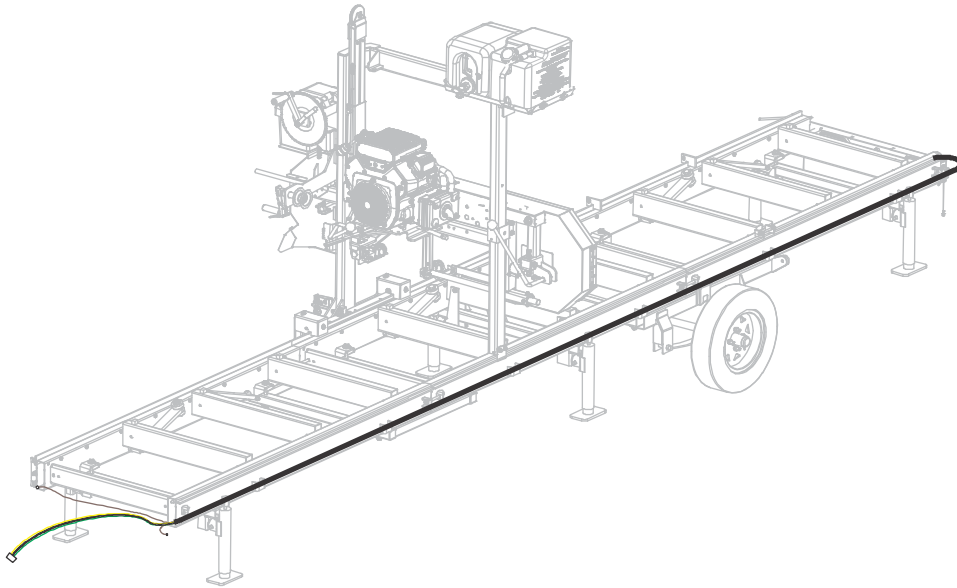

FIG. 1-9

1. Route the main wiring harness inside the sawmill main bed tube from the light bar to the front.

NOTE: Run a fish tape from the front end of the sawmill bed to the back to install the wire harness.

See Figure 1-10.



150233-23

FIG. 1-10

2. Remove the front rope bracket and hardware from the sawmill bed. Retain the bushing, washer, and rope bracket for reinstallation.

Install the tongue frame

See Figure 1-11.

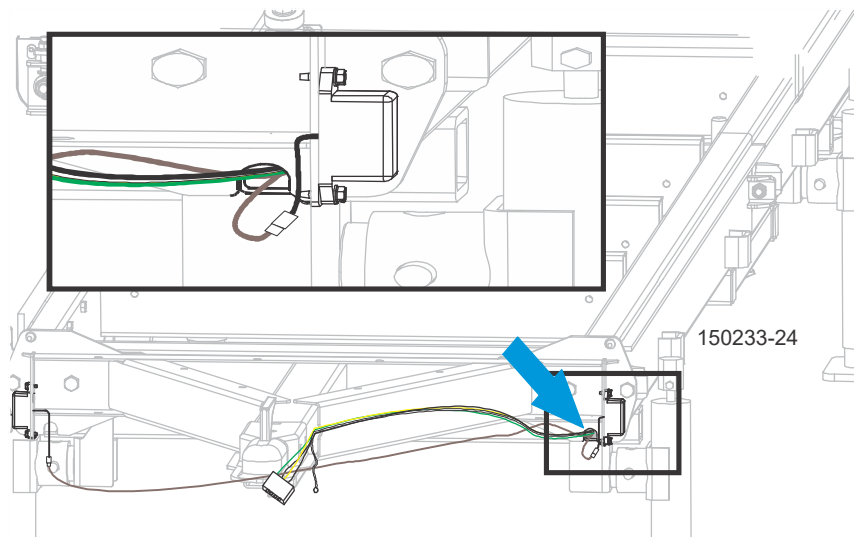

150233-24

FIG. 1-11

1

Trailer Assembly

Tongue Frame & Rear Light Bar Installation

NOTE: Feed the wiring harness through the space on the tongue weldments allotted for the wiring harness to pass through. Do not pinch the wires during installation.

NOTE: The brown wire to the nearest clearance light is short and may have remained inside the main bed tube.

1. To tighten the tongue weldment, start at the front rope bracket in order to assure the proper alignment. Reuse the rope bracket, washer, and bushing removed previously. Do not reuse the nylon lock nut; a new nut is provided.

See Figure 1-12.

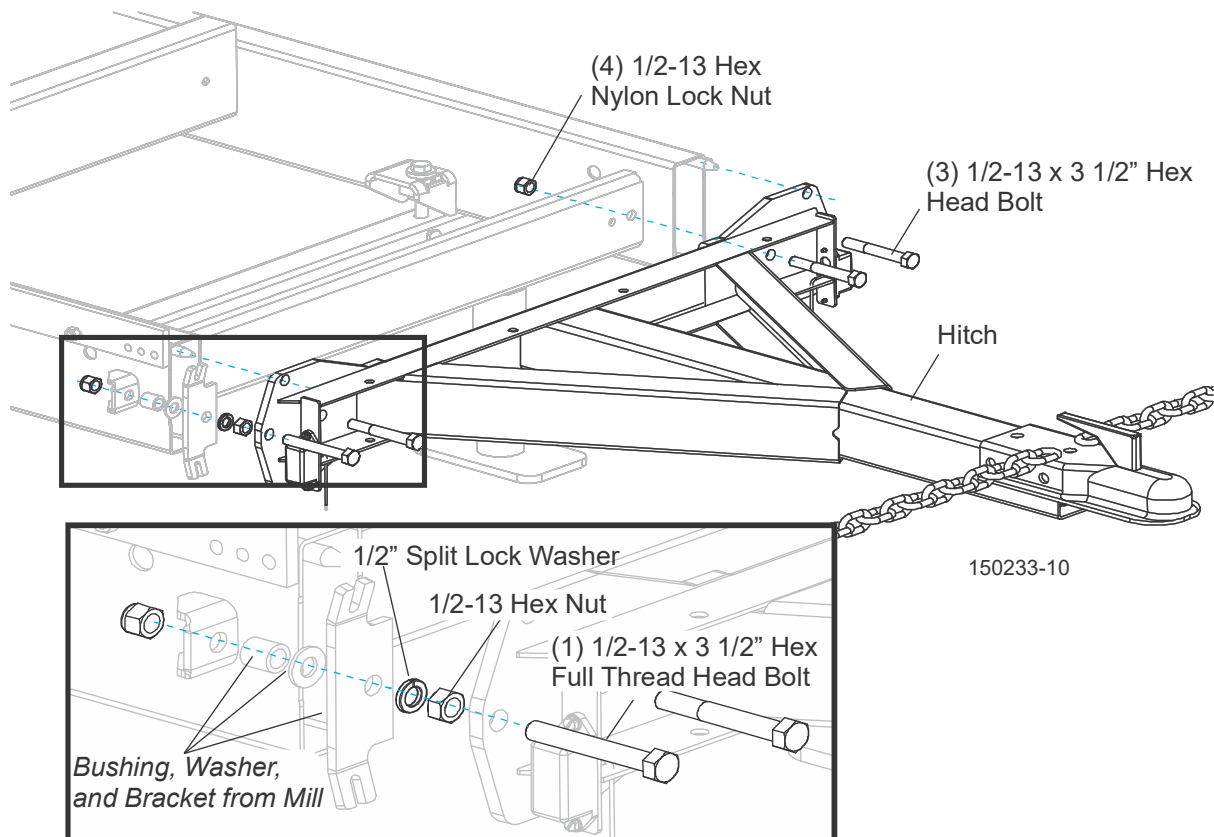

FIG. 1-12

2. Connect the two brown wires from the harness to the black wires on the clearance lights.

See Figure 1-13.

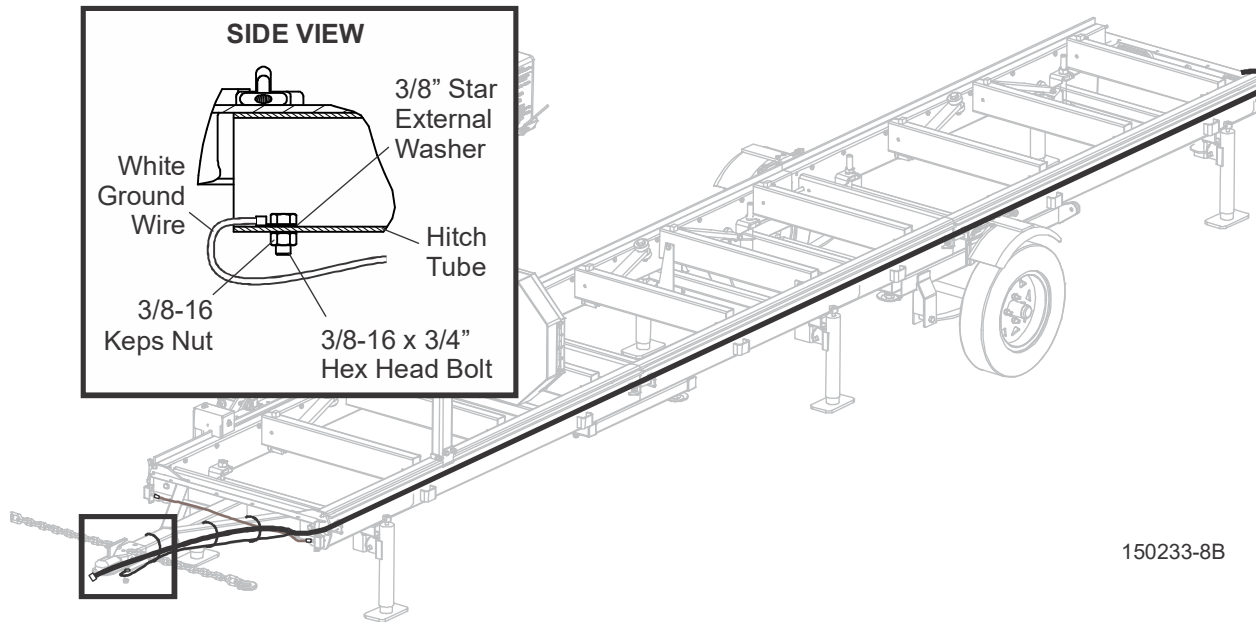

FIG. 1-13

3. Connect the white ground wire to the ground bolt under the hitch and secure with the provided nut.



IMPORTANT: Make sure the serrated lock washers break through the paint on the hitch.

1.6 Up/Down Handle Conversion

Because the sawmill sits higher when mounted to the optional trailer, it can be necessary to convert the up/down crank handle to a lower position.

1. Move the saw head to rear of the sawmill and lower all the way down. Lower the saw head until it rests on the bed to provide slack in the up/down chain.

1 Trailer Assembly

Up/Down Handle Conversion

2. Disassemble the feed handle/crank assembly from the sawmill mast.

See Figure 1-14.

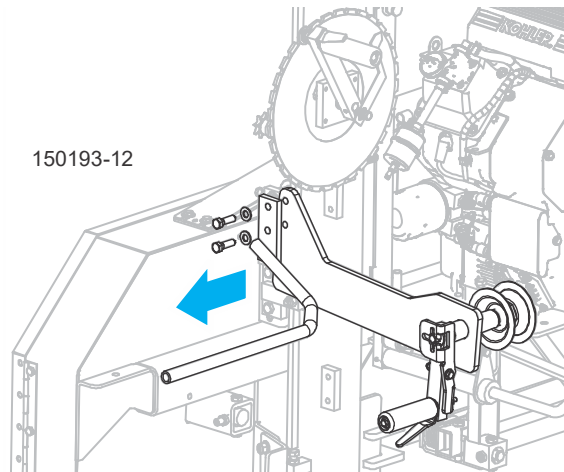

FIG. 1-14

3. **LT15 Rev. E4.00 - E6.07 only:** Drill two 5/16" diameter holes in the mast vertical tube at the locations specified. Tap the holes with 3/8-16 threads. **Note:** LT15 Rev. E6.08 include a block with a threaded hole welded at the upper location. LT15 Rev. E6.09 and newer include a block with two threaded holes welded at this location.

See Figure 1-15.

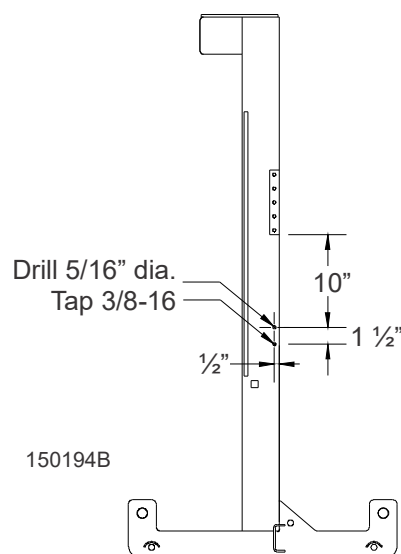

FIG. 1-15

4. Assemble the feed handle/crank assembly to the lower holes with the existing split lock washers and hex head bolts. If you added a threaded hole(s) to the mast at this location, fill the space between the mast and the mounting bracket with spacers such as flat washers.

See Figure 1-16.

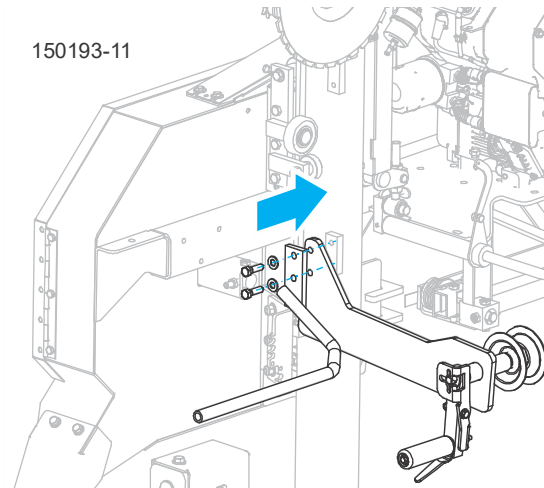

FIG. 1-16

5. Disassemble the two bolts and housing from the back of the up/down crank handle assembly as shown below. The gear reducer guard may be discarded or retained if you wish to revert back to the no-trailer configuration later.

See Figure 1-17.

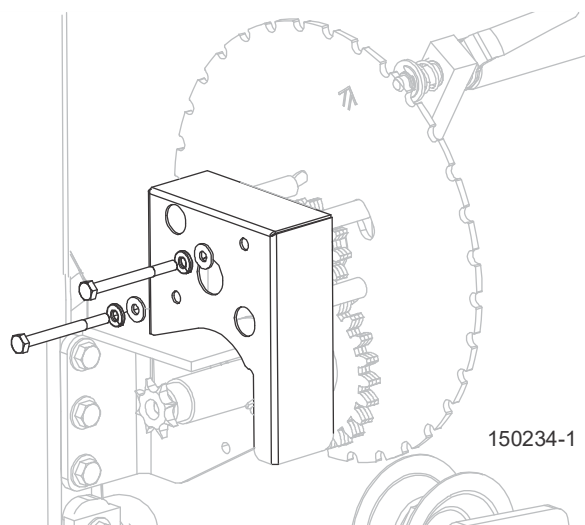

FIG. 1-17

1

Trailer Assembly

Up/Down Handle Conversion

6. Remove the two bolts holding the gear reducing handle to the chain mount. Replace one of the bolts removed in Step 2, and remove a third bolt, as shown below.

See Figure 1-18.

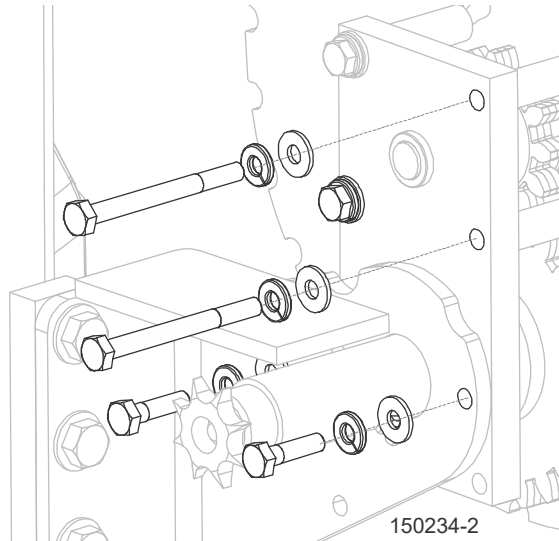

FIG. 1-18

7. Rotate the up/down crank handle assembly and reattach to the chain mount using the washers and bolts removed in the step above.
8. Attach the provided up/down assembly guard to the up/down crank handle and secure with the provided fasteners as shown below.

See Figure 1-19.

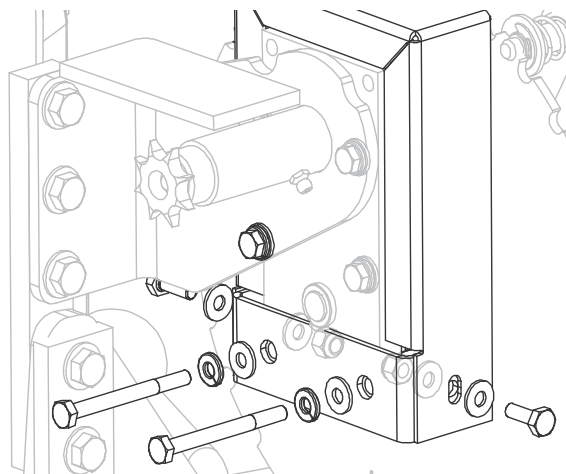

FIG. 1-19

1.7 Final Installation

1. If necessary, adjust the up/down chain tensioner bolt to retighten the chain. Turn the up/down crank handle to lift the saw head off of the bed. Continue adjusting the tensioner bolt until there is 1" of total deflection at the middle of the chain span. Tighten the bottom sprocket mount bolt and replace the sprocket cover.
2. Install the provided saw head rest pin to the blade guide arm housing with the 1/4-20 x 2 3/4" hex head bolt, split lock washer, lanyard and safety pin. Install the head rest plate to the sawmill bed as shown.

See Figure 1-20.

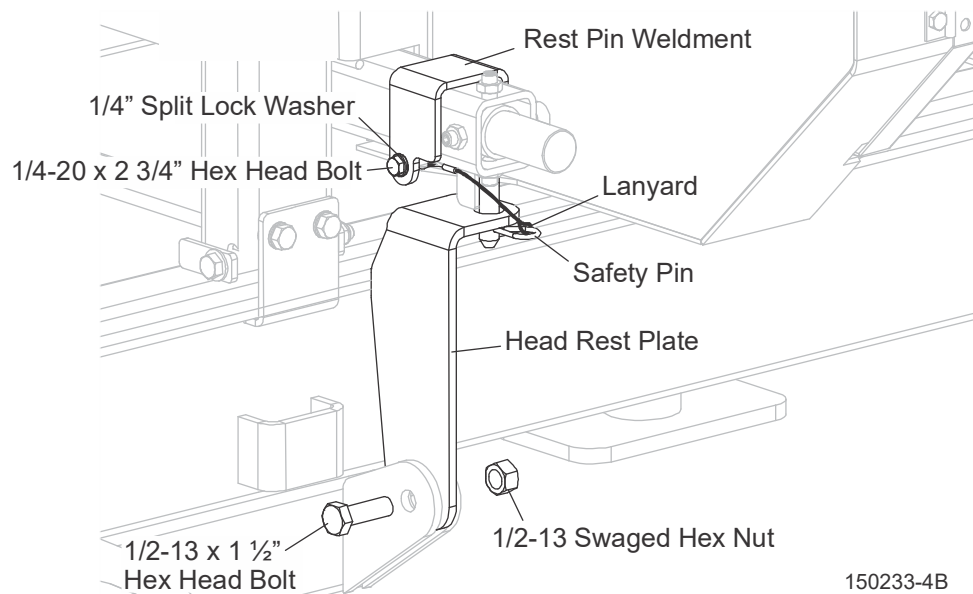

FIG. 1-20

3. Install the trailer fenders to the trailer and secure with the locking straps.

1 Trailer Assembly

Final Installation

See Figure 1-21.

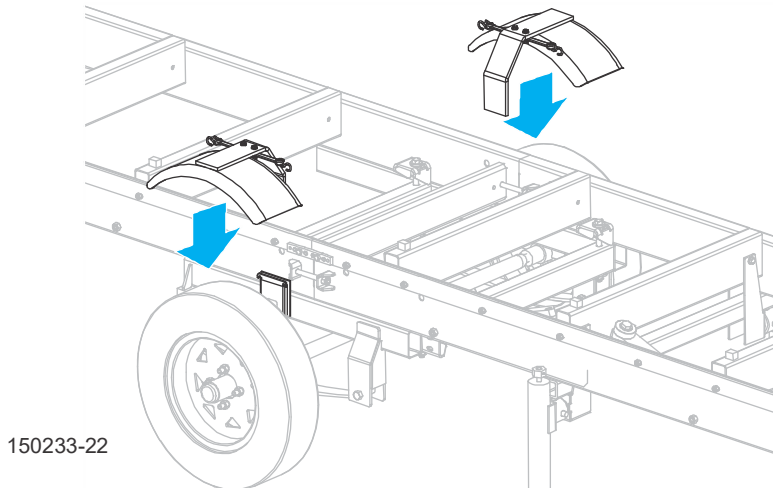

FIG. 1-21

4. Install the two provided red reflectors on each side of the rear of the saw head.

See Figure 1-22.

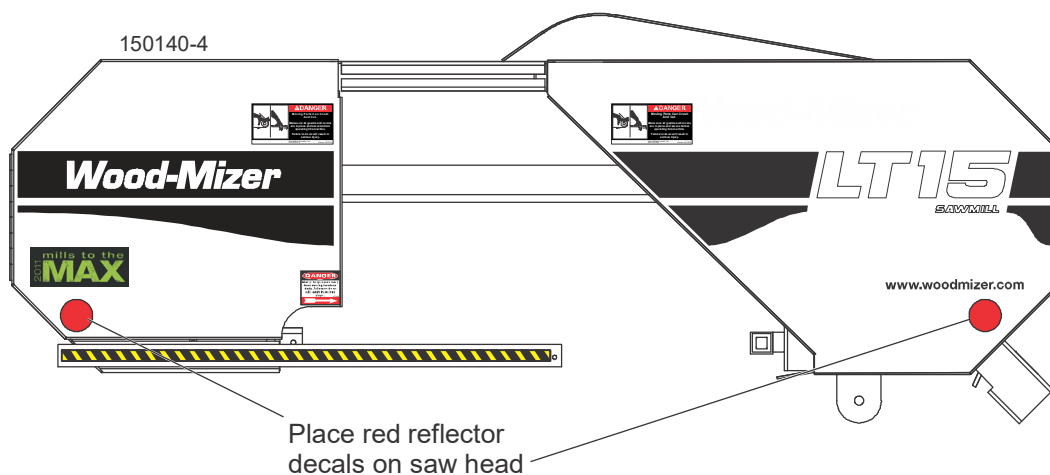

FIG. 1-22

5. Install the two provided yellow and red reflectors on each side of the sawmill bed. Install the LT15GO decal to the saw head cross bar.

See Figure 1-23.

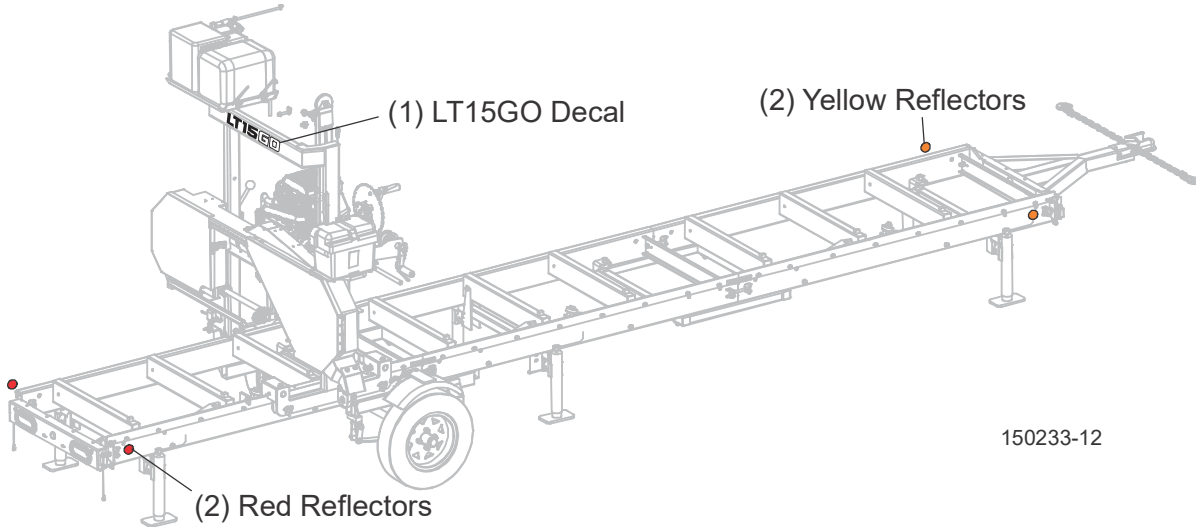

FIG. 1-23

6. Refer to your LT15 manual to perform the sawmill setup procedure to ensure proper alignment prior to sawing.

1.8 Travel Position Hole

See Figure 1-24. Check the rear bed section for the travel position hole location. Drill one 11/16" hole in the bed tube as shown below, if needed (LT15 sawmills built prior to 4/15).

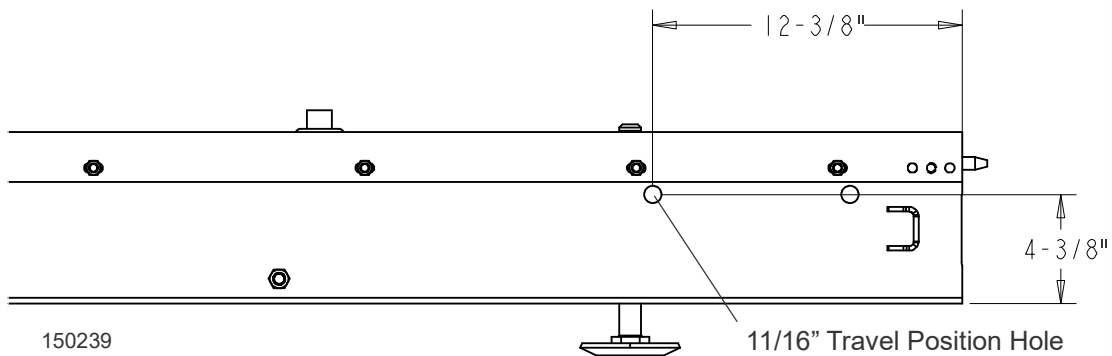

FIG. 1-24

1 Trailer Assembly

Winch Installation (Optional)

1.9 Winch Installation (Optional)

The winch and loading ramps are optional (part no. LT15TRG2-LLKIT). Perform the following steps to install the winch to the trailer.

1. Install the winch mount to the trailer as shown below. Use the provided fasteners to secure the winch mount in place.

See Figure 1-25.

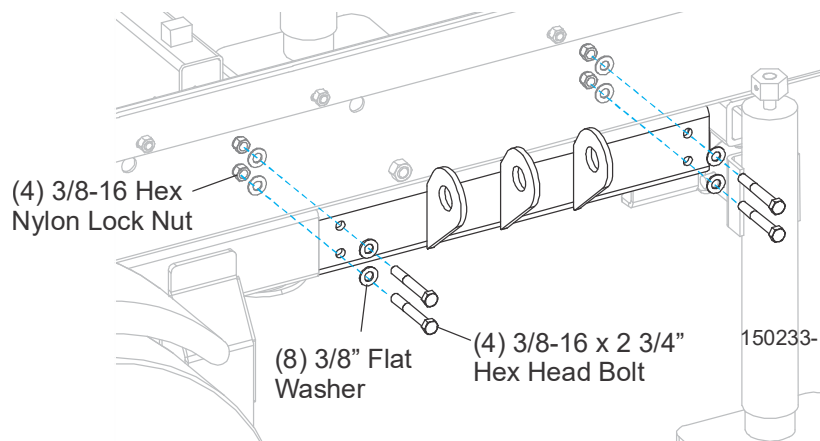

FIG. 1-25

2. Install the winch to the winch mount. Use the provided pins and washers to secure the winch to the trailer.

See Figure 1-26.

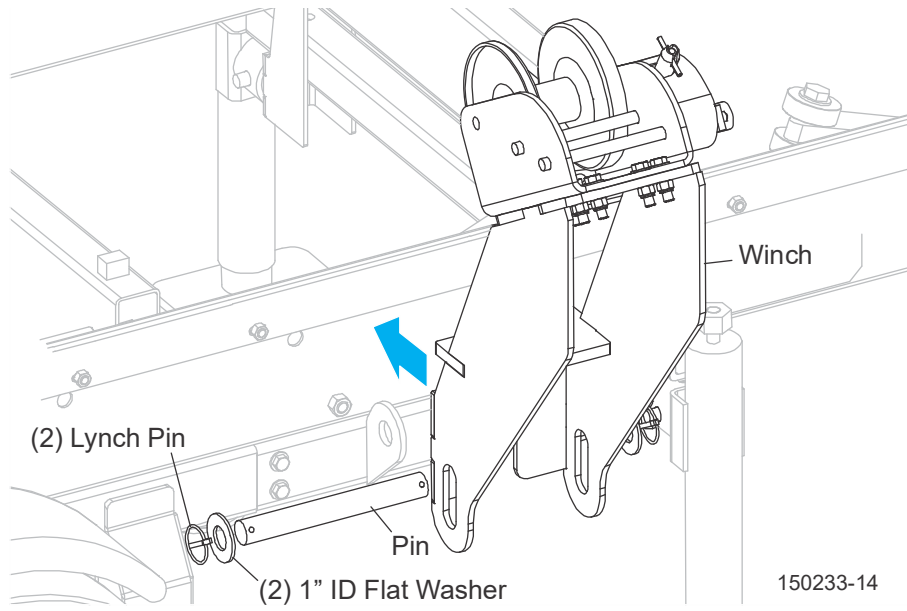

FIG. 1-26

SECTION 2 TRAILER OPERATION

2.1 Preparing The Sawmill For Travel



IMPORTANT! Your vehicle should be equipped with a Class 2 hitch with a solid 2" ball (not two-piece) and rated for at least 3500 pounds (1588 kg). The hitch should be correctly mounted to the towing vehicle so that it will be able to pull this type of load.

1. Move the saw head to the front of the sawmill and raise the rear jacks.
2. Disconnect the water hose (and fuel hose if equipped) and remove the water tank (and fuel tank, if equipped) from the saw head mast.



WARNING! Secure the saw head in the travel position before towing the sawmill. Failure to do so may result in damage to the machine.

3. Replace the fenders in the brackets behind each wheel and secure with the locking straps.

See Figure 2-1. .

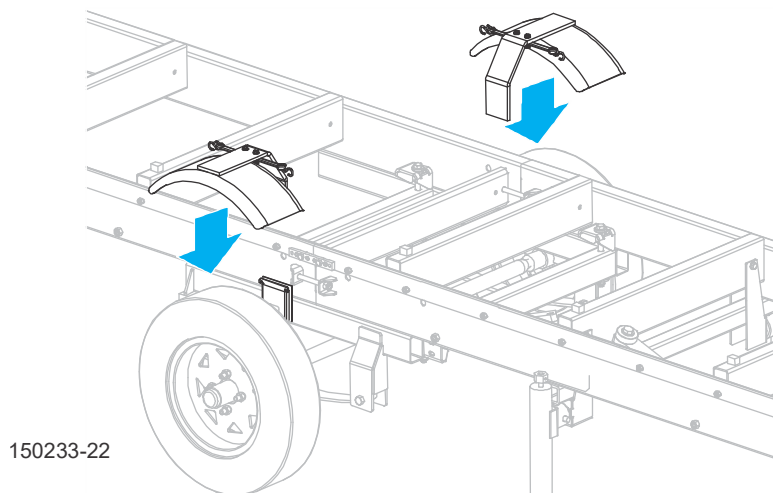

FIG. 2-1

4. Move the saw carriage to the travel position and secure the travel lock pins.

5. Align the head with the head rest plate and lower the saw head until the pin engages the bracket. Secure with the safety pin.

See Figure 2-2.

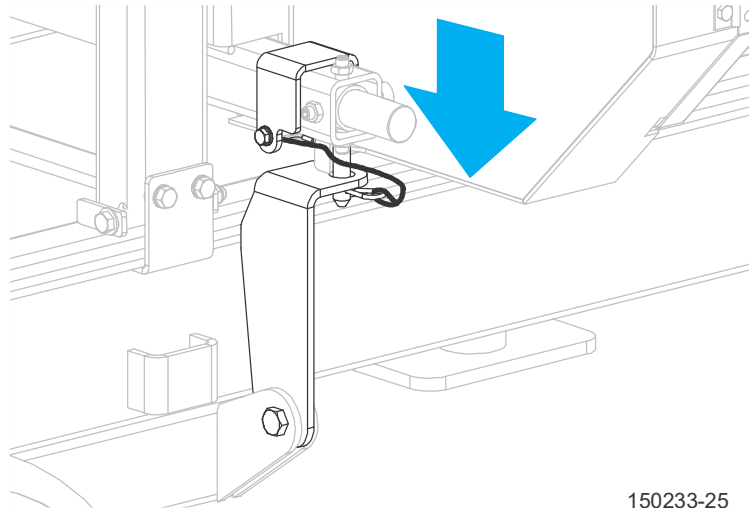

FIG. 2-2

6. *If the options are included*, place log loading ramps in the towing vehicle. Raise the winch to upright position.
7. Rotate all but the very front jacks to the travel position.
8. Align the mill behind the towing vehicle and place the hitch over the ball coupling on your vehicle. Adjust the front jacks to lower the trailer until the hitch engages the ball. Adjust the coupler if necessary so it is as tight as possible on the ball and the locking lever can still be opened and closed.
9. Flip the locking handle downward being sure the bracket underneath firmly clamps around the ball. Secure the locking handle with the safety pin.



DANGER! Make sure hitch bracket is securely fastened around ball before towing the sawmill. Ball should be completely engaged by the hitch bracket and securely locked in place. Use the hitch only with the specified ball size. Failure to do so may result in serious personal injury and/or severe machine damage.

10. Cross the safety chains underneath the hitch and hook to the vehicle. The chains should be connected so that there is still slack in the chains when the vehicle is turned sharply in either direction.



DANGER! Make sure your towing vehicle has adequate safety chain hookups. Do not use eyebolts for safety chain hook-up. Safety chains should be hooked to bumper of vehicle so that each chain would pull the trailer equally in the event the hitch became disengaged. Failure to do so may result in serious personal injury and/or severe machine damage.

See Figure 2-3.

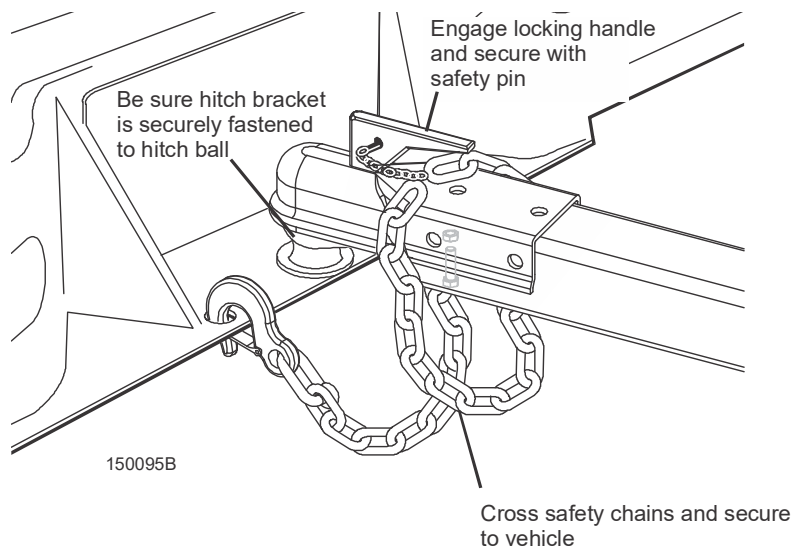

FIG. 2-3

11. Connect the trailer light harness to the towing vehicle light plug.
12. Rotate the front jacks all the way up into the travel position.
13. Recheck that all loose items are removed or secured (such as Shingle/Lapsiding Option, cant hooks, etc.).
14. Make sure all connections are secure and trailer lights are working properly.



DANGER! Be sure that the hitch and safety chains are secure before towing the sawmill. Failure to do so may result in serious personal injury and/or severe machine damage.



DANGER! Make sure all light connections have been made and are working properly before towing the sawmill. Failure to do so may result in serious personal injury and/or severe machine damage. Make sure you have complied with all applicable Federal State and Local motor vehicle safety laws.

15. Check tires for proper inflation.



WARNING! Always check trailer tires for proper inflation before towing sawmill. Failure to do so may lead to tire failure resulting in property damage and/or serious injury or death.

2.2 Preparing The Sawmill For Operation



WARNING! Do not set up the mill on ground with more than a 10 degree incline. If setup on an incline is necessary put blocks under one side of the mill or dig out areas for jacks to keep mill level. Setting up the mill on an incline could cause it to tip over resulting in serious personal injury.



WARNING! Chock the trailer wheels to prevent movement before unhitching it from the towing vehicle. Failure to do so may result in serious injury or death.



WARNING! Always make sure the trailer is supporting the sawmill frame when operating a sawmill with jacks. Failure to do so may result in serious injury or death. The jacks are intended to support the saw frame with assistance from the trailer.



WARNING! The jacks supplied with portable sawmills are not intended for setup on concrete or other hard surfaces. Long-term use of the jacks on hard surfaces may cause the jacks to fail causing the sawmill to drop. This could result in possible serious injury or death.

If setting the sawmill up on concrete or other hard surface replace the jacks with stationary legs.



WARNING! Put front jack down before moving cutting head from the rest position. Failure to do so may result in serious injury.

1. Position the sawmill in an area that is suitable for sawing.
2. Chock the trailer wheels to prevent movement while unhitching the trailer.
3. Unhook the safety chains and light harness from the vehicle and unhitch the sawmill. Lower the front jacks and set on the ground.
4. Release the winch cable (optional) and remove the log loading ramps (optional) from the sawmill.
5. Remove the saw head safety pin and raise the saw head from the rest bracket. Remove the rest bracket from the sawmill bed.
6. Move the saw carriage to the front of the sawmill and lower the remaining jacks. Use the provided crank handle to adjust the jacks to lift weight from the trailer axle and level the sawmill.

See Figure 2-4.

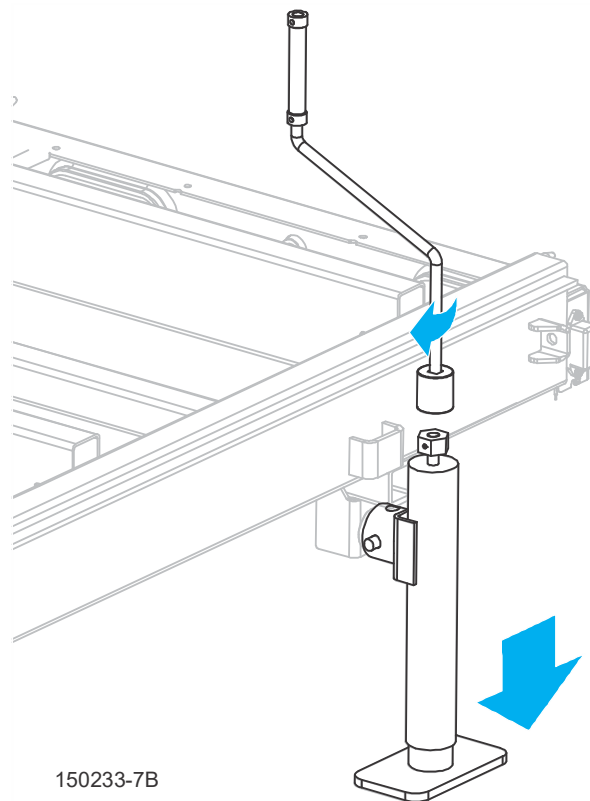

FIG. 2-4. JACK ADJUSTMENT.

7. Disengage the fender locking straps and lift the fenders from the trailer and set aside.
8. Place the log loading ramps (optional) in the brackets provided on the side of the sawmill bed.

2

Trailer Operation

Loading A Log using Optional Ramps and Winch

See Figure 2-5.

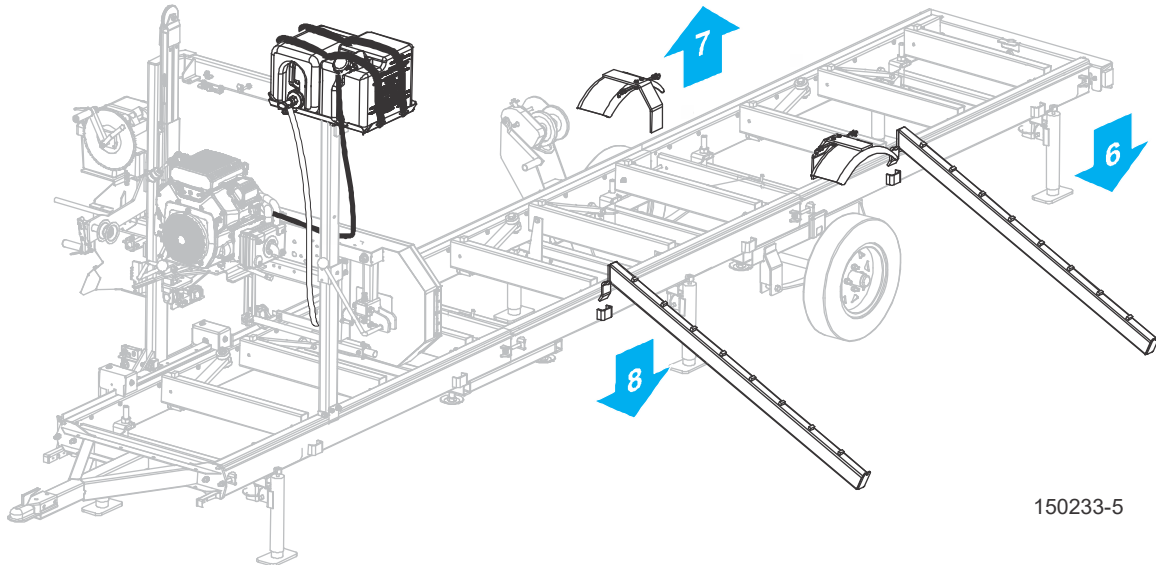

FIG. 2-5

9. Install the water tank (and fuel tank, if equipped) to the saw head mast. Connect the water hose (and fuel hose, if equipped) as required.

2.3 Loading A Log using Optional Ramps and Winch



DANGER! Keep all persons out of the path of moving equipment and logs when operating sawmill or loading and turning logs. Failure to do so will result in serious injury.

1. Position the log at the ends of the loading ramps centering the length of the log with the winch.
2. Raise the side supports to vertical to prevent the log from falling off the side of the sawmill.
3. Route the winch cable around the top of the log and back to the winch bracket. Attach the cable hook to the winch bracket.

See Figure 2-6.

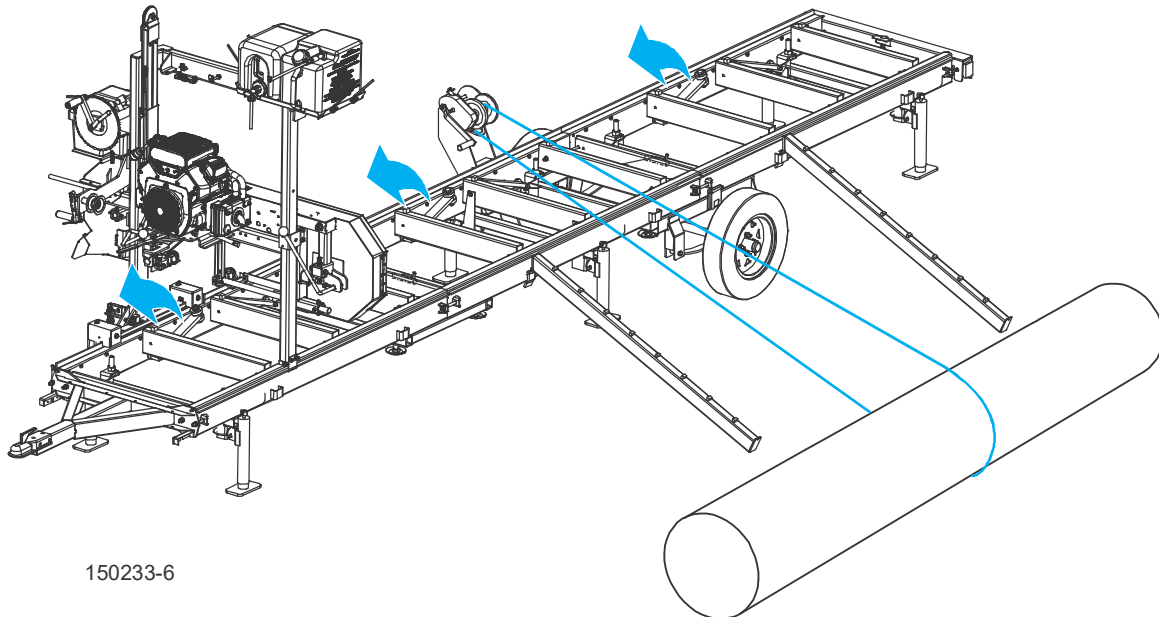

FIG. 2-6

4. To operate the winch:

Inspect the winch mechanism and cable for proper operation before each use. Check the cable for damage and replace if necessary. Refer to the manufacturer's manual for lubrication instructions.

The winch supplied is rated to handle 3000 pounds (1360 kg).

The winch features two-speed operation and a brake. To select the winch speed you want place the crank handle on the correct winding shaft. The top winding shaft provides a slow but stronger winding action. Use this top winding shaft when handling larger logs. The lower winding shaft will provide a faster winding action. Use when handling small to medium size logs.

To install the crank handle to either shaft press in the spring-loaded locking mechanism on the handle. Slide the handle onto the shaft and release the lock. To remove the crank handle press in the lock and slide the handle off the shaft.

To operate the brake make sure the brake strap is positioned over the brake cam. Push the brake handle against the brake strap. Release when the winch stops turning.



WARNING! Maintain a firm grip on the winch handle at all times and never release handle when ratchet lever is in unlocked position with a load on the winch. Otherwise handle will spin violently which could cause personal injury.

See Figure 2-7. To operate the winch use the winch handle. Turn the handle counter-clockwise to tighten the cable. To loosen the cable raise the winch direction pin turn it 90° and release it. (The pin rest arms should keep it in the raised position.) Now move the winch handle clockwise to loosen the cable. When finished turn the pin 90° and release. (The pin should return to its original position.)

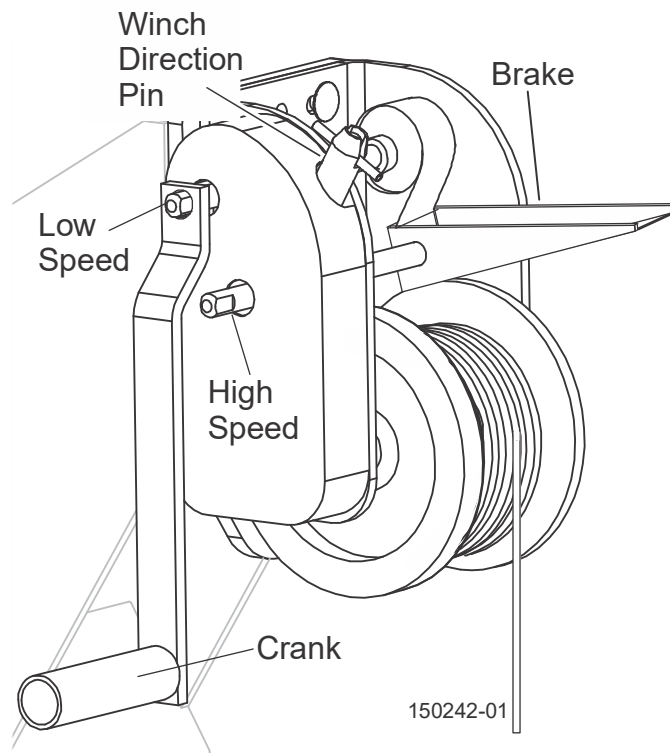

FIG. 2-7

5. Once the log is loaded disconnect the winch cable and wind the cable up. Lift the winch assembly and pivot down to the ground.
6. Adjust the side supports to clear the blade for the first few cuts.

SECTION 3 MAINTENANCE

1. Grease the trailer axle wheel bearings with lithium grease every 3 months or 1000 miles (1609 km) whichever comes first.
2. Make sure that the trailer tires are correctly inflated to the pressure shown on the tire.



CAUTION! Always check trailer tires for proper inflation before towing sawmill. Failure to do so may result in machine damage.

3. Check the adjustment of the trailer hitch coupler bracket frequently and adjust if necessary. Replace any bent or otherwise damaged parts before using the hitch. Use only parts provided by the hitch manufacturer for this hitch model.

4 Replacement Parts

Trailer (Complete)

SECTION 4 REPLACEMENT PARTS

4.1 Trailer (Complete)

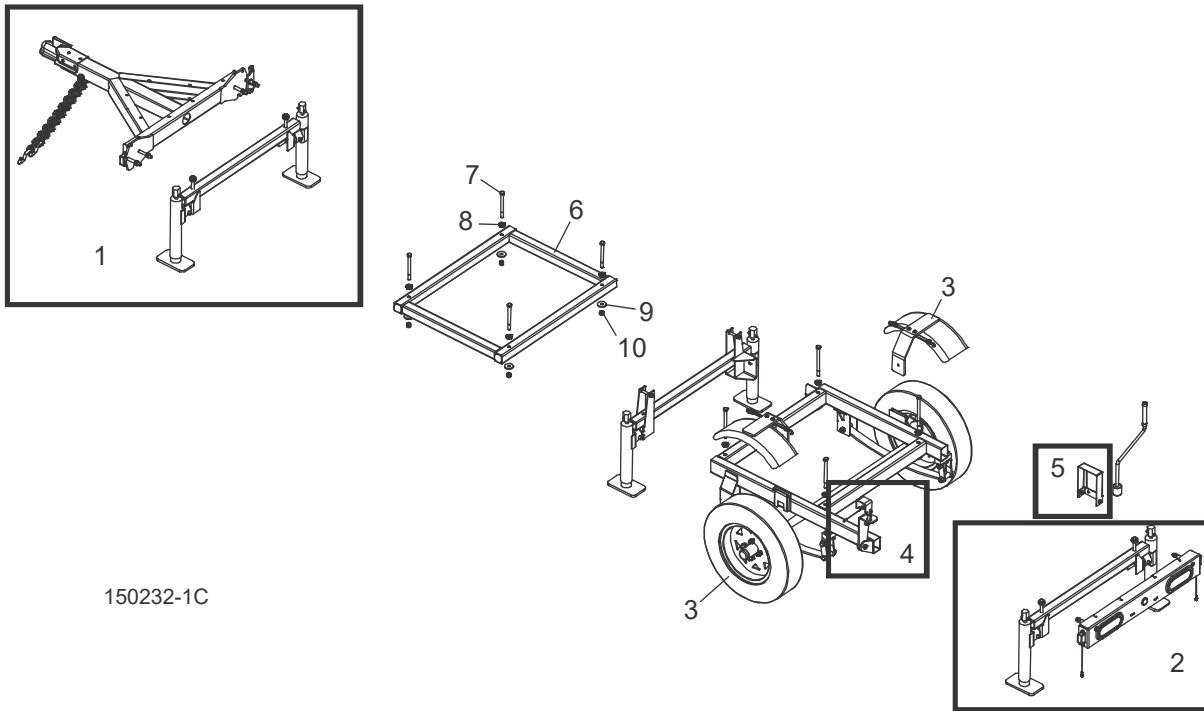

150232-1C

REF	DESCRIPTION (◆ Indicates Parts Available In Assemblies Only)	PART #	QTY.
	TRAILER KIT LT15GO2 FIELD INSTALL	LT15TRG2	1
	Trailer Assembly LT15TRG2	076226	1
1	Front Trailer Parts (See Section 4.2)		
2	Rear Trailer Parts (See Section 4.3)		
3	Axle/Fender & Middle Trailer Parts (See Section 4.5)		
4	Saw Head Rest Pin/Bracket Parts (See Section 4.6)		
5	Up/Down Guard Parts (See Section 4.7)		
6	Brace Weldment LT15 Trailer	076217	1
7	Bolt 1/2-13 x 5 1/2" Hex Head Grade 5 ¹	F05008-28	4
	Bolt 1/2-13 x 3 1/2" Hex Head Grade 5	F05008-61	4
8	Bushing Clamp	062461	4
9	Washer .52" X 1.69"	014632	4
10	Nut 1/2-13 Hex Nylon Lock	F05010-8	4
	Reflector 2 Dia Yellow	P07453	2
	Reflector 2 Dia Red	P07452	4
	Decal LT15GO	074622	3

¹ Bolts F05008-28 are used on LT15 revision E8.11; bolts F05008-61 are used on LT15 revision E8.12 or LT15W revision A1.13 and later.

4.2 Front Trailer Parts

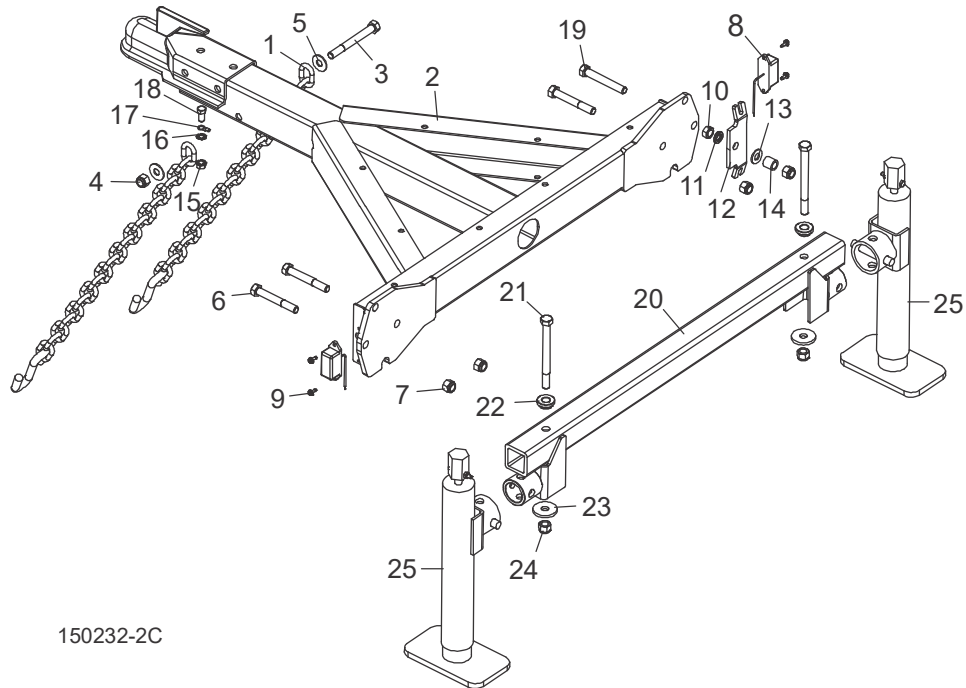

REF	DESCRIPTION (◆ Indicates Parts Available In Assemblies Only)	PART #	QTY.
	TONGUE ASSEMBLY LT15 TRAILER	074616	1
	Tongue Assembly, LT15	076227 ¹	1
1	Chain, 30 Inch Safety	107163	2
2	Hitch Weldment, LT15	110355	1
3	Bolt, 1/2-13x4 1/2 Hex Head Grade 5	F05008-35	1
4	Nut, 1/2-13 Nylon Hex Lock	F05010-8	1
5	Chain, Safety w/Hook	F05011-35	2
6	Bolt 1/2-13 x 3 1/2" Hex Head Grade 5	F05008-61	3
7	Nut 1/2-13 Hex Nylon Lock	F05010-8	4
8	Lamp Running Amber	P12906	2
9	Bolt #10-24 x1/2" Self Tap	F05015-7	4
10	Nut 1/2-13 Hex	F05010-35	1
11	Washer 1/2" Split Lock	F05011-9	1
12	Bracket Rope/Stop Left & Right	074463	1
13	Washer 1/2" SAE Flat	F05011-2	1
14	Spacer Pivot Lock Board Return	033911	1
15	Nut 3/8-16 Keps	F05010-19	1
16	Washer 3/8" Star External	F05011-36	1
17	Terminal 3/8 10-12Ga Ring NI Loose	F05092-23	1

4

Replacement Parts*Front Trailer Parts*

18	Bolt 3/8-16 x 3/4" Hex Head Grade 5	F05007-118	1	
19	Bolt 1/2-13 x 3 1/2" Full Thread Hex Head Tap	F05008-11	1	
	JACK ASSEMBLY LT15 TRAILER	076172	1	
20	Jack Weldment LT15	076170	1	
21	Bolt 1/2-13 x 5 1/2" Hex Head Grade 5 ²	F05008-28	2	
	Bolt 1/2-13 x 3 1/2" Hex Head Grade 5	F05008-61	2	
22	Bushing Clamp	062461	2	
23	Washer .52" X 1.69"	014632	2	
24	Nut 1/2-13 Hex Nylon Lock	F05010-8	2	
25	Adjustable Jack Parts (See Section 4.4)	076225	2	

¹ Replaced welded A07563 Safety w/Hook Chain (no longer available) with bolt-on plated chain and hook (Rev. A1.01).

² Bolts F05008-28 are used on LT15 revision E8.11; bolts F05008-61 are used on LT15 revision E8.12 or LT15W revision A1.13 and later.

4.3 Rear Trailer Parts

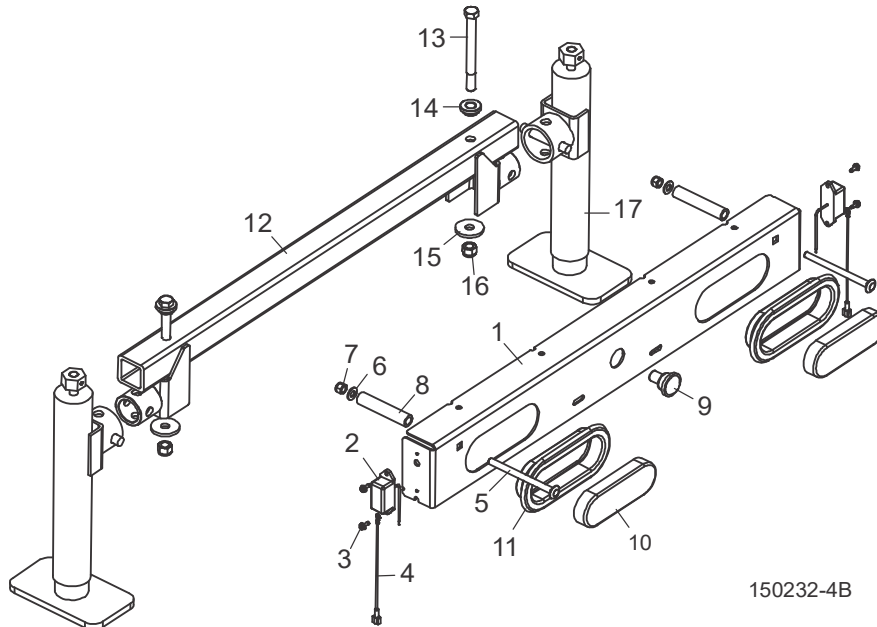

150232-4B

REF	DESCRIPTION (◆ Indicates Parts Available In Assemblies Only)	PART #	QTY.
	BAR ASSEMBLY REAR LIGHT	074607	1
1	Plate Rear Light Bracket	074601	1
2	Lamp Running Red	P12905	2
3	Bolt #10-24 x 1/2 Self Tap	F05015-7	4
4	Wire Assembly Ground LT15GO2	074617	2
5	Bolt 3/8-16 x 5" Carriage	F05007-113	2
6	Washer 3/8 Flat SAE	F05011-3	2
7	Nut 3/8-16 Hex Nylon Lock	F05010-10	2
8	Tube Spacer LT15 Trailer	074663	2
9	Lamp 1 1/4" License Plate	P09928	1
10	Light 8 Diode LED Tail	006391	2
11	Grommet 6 1/2" Light Mounting	006688	2
	Harness Trailer Lights LT15TRG	074647	1
	JACK ASSEMBLY LT15 TRAILER	076172	1
12	Jack Weldment LT15	076170	1
13	Bolt 1/2-13 x 5 1/2" Hex Head Grade 5 ¹	F05008-28	4
	Bolt 1/2-13 x 3 1/2" Hex Head Grade 5	F05008-61	4
14	Bushing Clamp	062461	2
15	Washer .52" X 1.69"	014632	2
16	Nut 1/2-13 Hex Nylon Lock	F05010-8	2
17	Adjustable Jack Parts (See Section 4.4)	076225	2

¹ Bolts F05008-28 are used on LT15 revision E8.11; bolts F05008-61 are used on LT15 revision E8.12 or LT15W revision A1.13 and later.

4 Replacement Parts

Adjustable Jack Assembly

4.4 Adjustable Jack Assembly

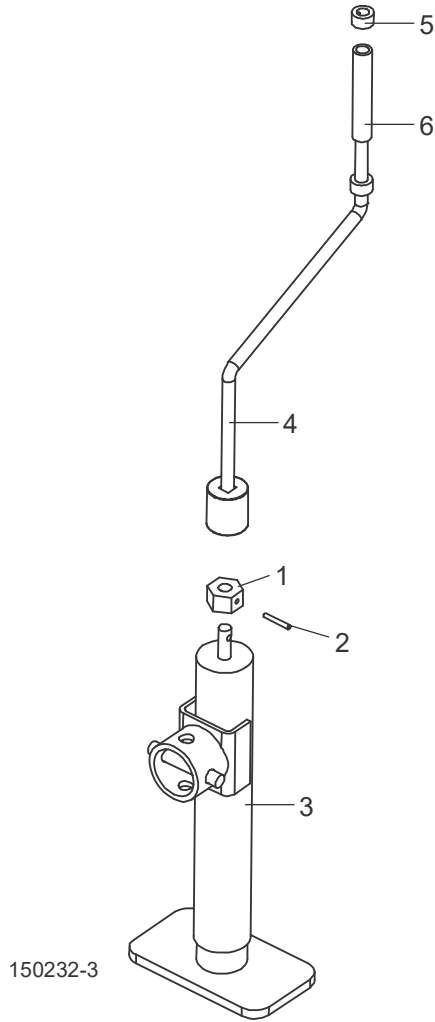

REF	DESCRIPTION (◆ Indicates Parts Available In Assemblies Only)	PART #	QTY.	
	JACK ASSEMBLY LT15 ADJUSTABLE	076225	1	
1	Nut Jack Hex 1-1/4" x 1/2" ID	076224	1	
2	Pin 3/16" x 1 1/4" Roll	F05012-16	1	
3	Jack 10"	X200-942	1	
	HANDLE ASSEMBLY ADJUSTMENT JACK CRANK	056831	1	
4	Crank Weldment Adjustment Jack	056827	1	
5	Collar Lock 1/2IDx7/8OD	014820	2	
6	Jack Crank Handle	056830	1	

4.5 Axle/Fender & Middle Trailer Parts

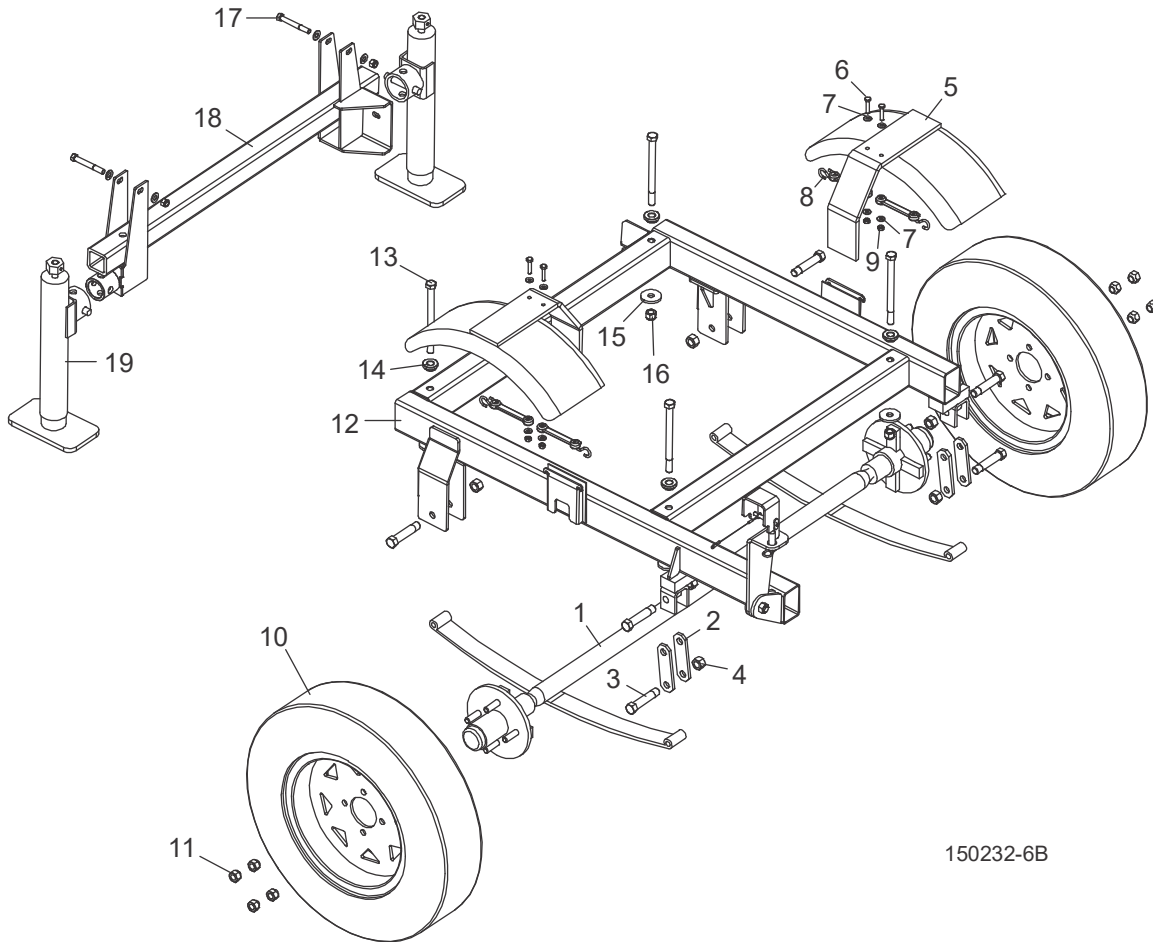

150232-6B

REF	DESCRIPTION (◆ Indicates Parts Available In Assemblies Only)	PART #	QTY.	
1	AXLE 2200LB LEAF SPRING	065404	1	
2	PLATE PAINTED AXLE SHACKLE LINK	M07528	4	
3	BOLT 9/16-18 X 3' AXLE SHACKLE	P04644	6	
4	NUT 9/16-18 HEX LOCK	P04643	6	
	FENDER ASSEMBLY LT15TRG2 TRAILER	130762 ¹	2	
5	Fender Weldment LT15TRG2	130753 ²	1	
6	Bolt 1/4-20 x 1 1/4" Hex Head Full Thread	F05005-3	2	
7	Washer 1/4" SAE Flat	F05011-11	2	
8	Strap 6" Rubber	016542	2	
9	Nut 1/4-20 Hex Lock	F05010-21	2	
10	TIRE/WHEEL ASSEMBLY ST145R12 LOAD RANGE D	065401	2	
11	NUT 1/2-20 LUG	P04646	8	
12	AXLE WELDMENT LT15 TRAILER	076223	1	

4**Replacement Parts***Axle/Fender & Middle Trailer Parts*

13	BOLT 1/2-13 X 6 1/2" HEX HEAD GRADE 5³	F05008-159	4	
	BOLT 1/2-13 X 4 1/2" HEX HEAD GRADE 5	F05008-35	4	
14	BUSHING CLAMP	062461	4	
15	WASHER .52" X 1.69"	014632	4	
16	NUT 1/2-13 HEX NYLON LOCK	F05010-8	4	
17	BOLT 3/8-16 X 3" HEX HEAD GRADE 5	F05007-73	2	
	JACK ASSEMBLY LT15 CENTER	076173	1	
18	Jack Weldment, LT15 Rear	076175	1	
19	Adjustable Jack Parts (See Section 4.4)	076225	2	

¹ Fender assembly 025951 was replaced by 130762 on 4/2/2020 by ECN 37370.

² Fender weldment 062463 was replaced by 130753 on 4/2/2020 by ECN 37370.

³ Bolts F05008-159 are used on LT15 revision E8.11; bolts F05008-35 are used on LT15 revision E8.12 or LT15W revision A1.13 and later.

4.6 Saw Head Rest Pin/Bracket Parts

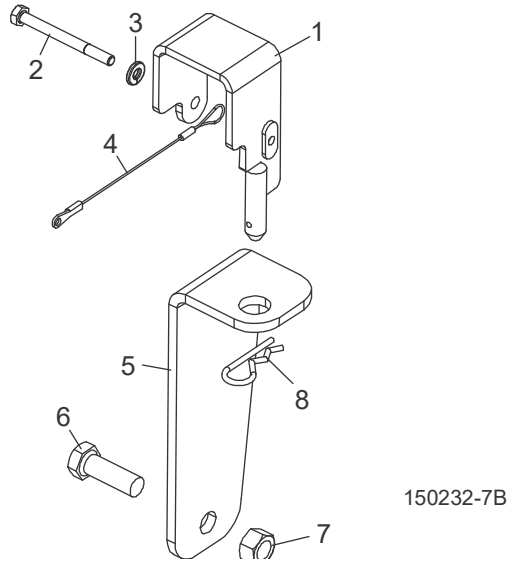

REF	DESCRIPTION (◆ Indicates Parts Available In Assemblies Only)	PART #	QTY.	
	REST ASSEMBLY LT15 HEAD	074662	1	
1	Pin Weldment LT15 Rest	059490	1	
2	Bolt 1/4-20 x 2 3/4" Hex Head Grade 5	F05005-18	1	
3	Washer 1/4" Split Lock	F05011-14	1	
4	Lanyard 3/64" x 6"	016030	1	
5	Plate Head Rest	062479	1	
6	Bolt 1/2-13 x 1 1/2" Hex Head Grade 5	F05008-33	1	
7	Nut 1/2-13 Swaged Hex	F05010-3	1	
8	Pin 1/8 x 1 13/16 Safety	P05059	1	

4 Replacement Parts

Up/Down Guard Parts

4.7 Up/Down Guard Parts

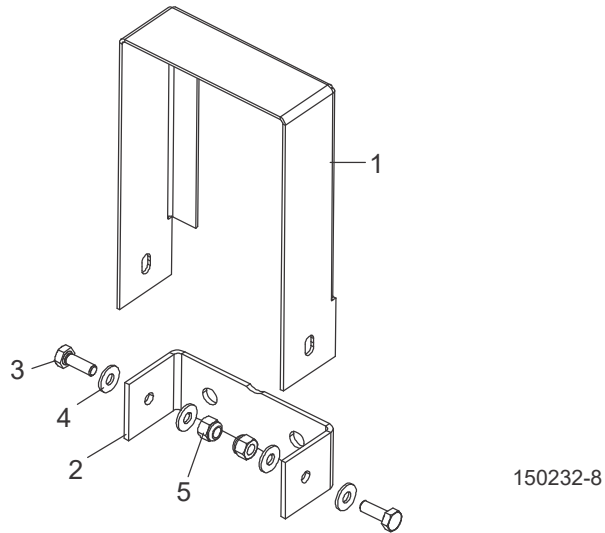

REF	DESCRIPTION (◆ Indicates Parts Available In Assemblies Only)	PART #	QTY.	
	GUARD ASSEMBLY LT15 UP/DOWN	074564	1	
1	Guard LT15 Trailer Up/Down	076270	1	
2	Mount LT15 Trailer Up/Down Guard	076269	1	
3	Bolt 1/4-20 x 3/4" Full Thread Hex Head Cap	F05005-1	2	
4	Washer 1/4" SAE Flat	F05011-11	4	
5	Nut 1/4-20 Nylon Lock	F05010-69	2	

4.8 Winch & Log Ramps Parts (Optional)

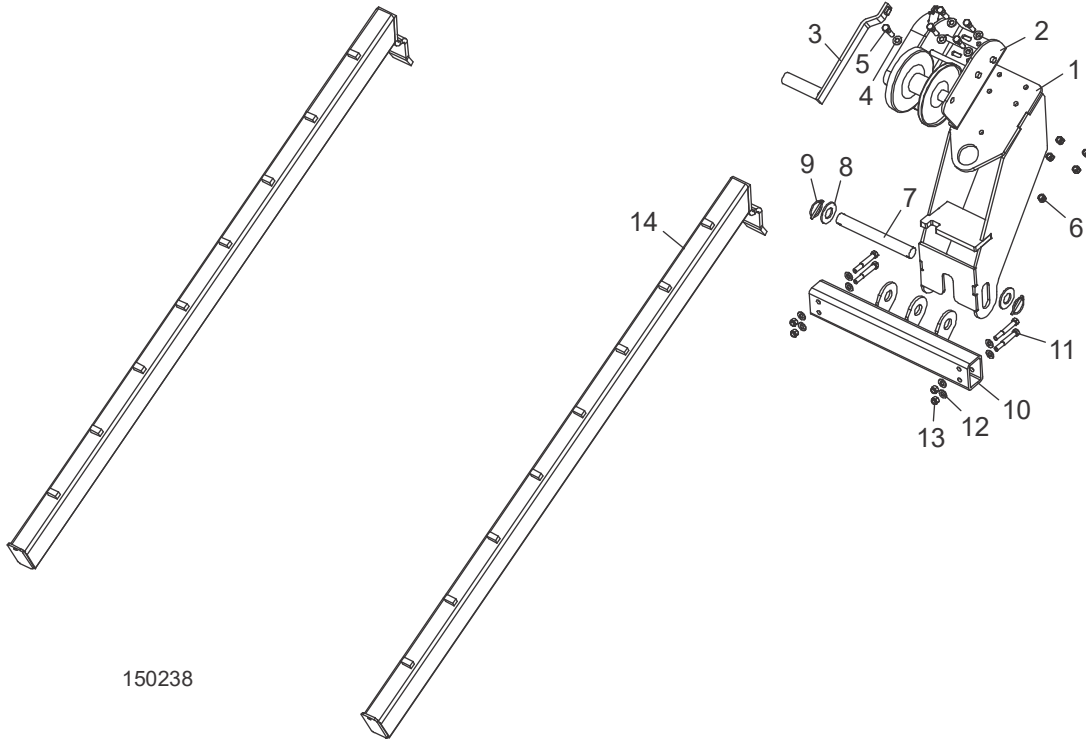

REF	DESCRIPTION (◆ Indicates Parts Available In Assemblies Only)	PART #	QTY.	
	TRAILER KIT WINCH AND LOG RAMPS (OPTIONAL)	LT15TRG2-LLKIT	1	
	Winch Assembly LT15 Trailer	076286	1	
1	Bracket Weldment Winch Mounting	076285	1	
2	Winch 3500lb DL3500B	P12323	1	
3	Handle Manual Winch	P04487	1	
4	Washer 3/8" SAE Flat	F05011-3	5	
5	Bolt 3/8-16 x 1 1/2" Hex Head Grade 5	F05007-78	5	
6	Nut 3/8-16 Hex Nylon Lock	F05010-10	5	
7	Pin 1" x 8 1/4"	062488	1	
8	Washer 1" SAE Flat	F05011-28	2	
9	Pin Lynch 3/16" w/Chain	017604	2	
	Cable 7/32" x 50' Winch (not shown)	P05087	1	
10	Mount Weldment LT15 Winch	076268	1	
11	Bolt 3/8-16 x 2 3/4" Hex Head Grade 5	F05007-206	2	
12	Washer 3/8" Flat SAE	F05011-3	8	
13	Nut 3/8-16 Hex Nylon Lock	F05010-10	4	
14	Ramp Weldment LT15 Log Loading	062434	2	



I

installation

- feed & up/down handle relocation 12
- final steps 16, 18, 20
- pre-assembled sawmill 1, 4
- unassembled sawmill 8

M

maintenance

- tire pressure 1
- trailer axle wheel bearings 1

O

operation 1

- loading a log 7
- prepare for operation 4
- prepare for travel 1

P

parts

- axle/fenders 6
- front trailer 2
- outrigger 5
- rear trailer 4
- saw head rest pin/bracket 8
- trailer complete 1
- up/down 9
- winch 6