

**Wood-Mizer® Resaw
Safety, Setup, Operation &
Maintenance Manual**

HR300 Series

rev. A2.02

Safety is our #1 concern!

Form #1694



WARNING! Read and understand this manual before using this machine.

California
Proposition 65 Warning



WARNING: Breathing gas/diesel engine exhaust exposes you to chemicals known to the State of California to cause cancer and birth defects or other reproductive harm.

- Always start and operate the engine in a well-ventilated area.
- If in an enclosed area, vent the exhaust to the outside.
- Do not modify or tamper with the exhaust system.
- Do not idle the engine except as necessary.

For more information go to **www.P65warnings.ca.gov**.



WARNING: Drilling, sawing, sanding or machining wood products can expose you to wood dust, a substance known to the State of California to cause cancer. Avoid inhaling wood dust or use a dust mask or other safeguards for personal protection.

For more information go to **www.P65Warnings.ca.gov/wood**.

Active Patents assigned to Wood-Mizer, LLC

Wood-Mizer, LLC has received patents that protect our inventions which are a result of a dedication to research, innovation, development, and design. Learn more at: woodmizer.com/patents

©August 8, 2023 Wood-Mizer LLC

Printed in the United States of America, all rights reserved. No part of this manual may be reproduced in any form by any photographic, electronic, mechanical or other means or used in any information storage and retrieval system without written permission from

Wood-Mizer, LLC
8180 West 10th Street
Indianapolis, Indiana 46214

SECTION 1 INTRODUCTION

1.1 About This Manual 1-1

1.2 Getting Service..... 1-2

General Contact Information 1-2

Wood-Mizer Locations 1-3

1.3 Customer and Equipment Identification 1-4

1.4 Dimensions..... 1-5

HR300 Series Resaw w/Optional Loading Tables 1-6

1.5 Specifications 1-7

SECTION 2 SAFETY

2.1 Safety Symbols 2-1

2.2 Safety Instructions..... 2-1

SECTION 3 SETUP AND OPERATION

3.1 Setup..... 3-1

3.2 Electrical Installation 3-1

3.3 Replacing The Blade 3-4

3.4 Tensioning The Blade 3-5

3.5 Tracking The Blade..... 3-6

3.6 Starting And Stopping The Machine 3-7

3.7 Up/Down Operation 3-8

3.8 Saw Head Tilt Adjustment..... 3-8

3.9 Pressure Roller Adjustment 3-9

3.10 Water Lube Operation..... 3-10

3.11 The Lube-Mizer System (Optional)..... 3-11

3.12 Loading Tables Installation (Optional) 3-13

3.13 Pre-Operation Check..... 3-14

3.14 Operation Procedure 3-15

SECTION 4 MAINTENANCE

4.1 Blade Guides 4-1

4.2 Sawdust Removal..... 4-2

4.3 Blade Wheel Belts..... 4-2

4.4 Tensioning the Belts..... 4-3

4.5 Tensioning the Chains..... 4-4

4.6 Drive Bearing..... 4-5

4.7 Checking the Rollers..... 4-6

4.8 Miscellaneous..... 4-6

4.9 Lube-Mizer (Optional)..... 4-7

SECTION 5 ALIGNMENT

5.1 Alignment Procedure.....5-1

- Blade Wheel Alignment*..... 5-1
- Saw Head Adjustment* 5-5
- Blade Guide Installation*..... 5-5
- Blade Guide Deflection*..... 5-7
- Blade Guide Vertical Tilt Alignment*..... 5-7
- Blade Guide Horizontal Tilt Adjustment*..... 5-9
- Blade Guide Flange Spacing* 5-10
- Blade Deflector Adjustment (Standard Guides Only)*..... 5-10
- Blade Guide Level (High-Performance Guides Only)* 5-11
- Blade Block Adjustment (High-Performance Guides Only)*..... 5-12
- Pressure Roller Adjustment* 5-13
- Blade Height Scale Adjustment*..... 5-14
- Brake Adjustment* 5-14

SECTION 6 ELECTRICAL INFORMATION

6.1 Electrical Symbol Diagrams.....6-1

- HR300EA10-1* 6-1
- HR300EB20-1* 6-2
- HR300EC20-1* 6-3
- HR300EH20-1*..... 6-4
- HR300EB25-1* 6-5
- HR300EC25-1* 6-6
- LMS-SHR Lube-Mizer Option*..... 6-7

6.2 Electrical Component List (HR300EC25-1)6-8

6.3 Electrical Component List (HR300EB25-1)6-9

6.4 Electrical Component List (HR300EC20-1)6-10

6.5 Electrical Component List (HR300EB20-1)6-11

6.6 Electrical Component List (HR300EH20-1)6-12

6.7 Electrical Component List (HR300EA10-1).....6-13

6.8 Component Layout Diagrams.....6-14

- Control Box (HR300EC20-1/HR300EH20-1/HR300EC25-1)*.....6-14
- Control Box (HR300EB20-1/HR300EB25-1)* 6-15
- Control Box (HR300EA10-1)*..... 6-16
- Control Box Door Panel* 6-17

Wood-Mizer® LLC
Limited Product Warranty



Wood-Mizer LLC (“Warrantor”), an Indiana corporation with its principal place of business at 8180 West Tenth Street, Indianapolis, IN 46214-2400 USA, warrants to the purchaser (“Purchaser”) that for the time periods specifically stated herein and subject to the terms, conditions and limitations stated herein, the equipment manufactured by the Warrantor will be free from defects in material and workmanship attributable to Warrantor so long as, during the warranty periods stated herein, the equipment is installed, operated and maintained in accordance with the instructions provided by Warrantor.

PRODUCT	MODEL CLASS	LENGTH OF WARRANTY		EFFECTIVE DATE
		USA & CANADA	NON USA & CANADA	
Portable Sawmills, Resaws, Edgers	LT, LX, HR, EG	Two years	One year	Date of purchase
Portable Sawmills with Chassis	LT28, LT35, LT40, LT50, LT70, LX450	Two years, excluding the chassis, which chassis shall have a five year warranty	One year	
Industrial Sawmills, Resaws, Edgers	WM, HR, EG, TVS, SVS	One year	One year	Date of purchase or date of installation / training (if applicable), whichever occurs first, not to exceed 6 months from date of purchase
TITAN Industrial	WB, TV, HR, EG, EA, MR	One year	One year	
Material Handling	TWC, IC, TD, LD, GC, CR, CB, CC	One year	One year	
Blade Maintenance Equipment	BMS, BMT, BMST	One year	One year	Date of purchase
Options and Accessories	Various	One year*	One year*	
Moulders, Extractors, Kilns	MP, MD, KS, KD	One year	One year	
Slab Flatteners	MB	Two years	One year	
Pallet Equipment	PD, PC	One year	One year	
Log Splitters	FS	One year	One year	
Replacement Parts	Various	90 days	90 days	

* Warranty on Options will match the warranty on the primary equipment when purchased on same invoice.

Exclusions from 90 Day, Limited One Year and Two Year Warranty

Warrantor shall have no responsibility under this warranty for any wear components, including, but not limited to: belts, blade guides, blades, electric motor brushes, drum switches, filters, fuses, hoses, bearings (excluding cylindrical drive bearings), bushings, cable carriers, and spark plugs. All wear components are furnished “as is”, without any warranty from Warrantor. This limited warranty does not cover any defects caused by misuse, negligence, alterations, damage due to overload, abnormal conditions, excessive operation, accident, or lack of performance of normal maintenance services.

Several components which are used in the manufacture of the equipment but not manufactured by Warrantor such as cant hooks, power plants, laser sights, batteries, tires, and trailer axles have warranties provided by the original equipment manufacturer (written copies available upon request). Warrantor does not separately warrant such items. Components or equipment manufactured by third parties are not covered by this warranty. Warrantor, however, will provide reasonable assistance to the Purchaser to make claims against any warranties applicable to such component parts as provided by such original equipment manufacturers. Components or equipment manufactured by third parties are not covered by this Warranty.

Five Year Limited Chassis Warranty

The limited five year chassis warranty described above, DOES NOT extend to (a) any damage stemming from accident, improper towing, overload, abuse, misuse, abnormal conditions, negligence, excessive operation, or lack of maintenance, (b) rust caused by exposure to corrosive atmospheric conditions, or (c) the sawmill head, carriage, axle, brakes, or any hydraulic or electrical components attached to the chassis.

Warrantor’s Obligations as To Defects

In the event that the equipment fails to perform due to defective materials or workmanship attributable to Warrantor under normal use and service within the established warranty period, Purchaser’s sole and exclusive remedy and Warrantor’s sole liability shall be to replace or repair, in Warrantor’s sole and subjective discretion, any defective part at Warrantor’s principal place of business without cost to the Purchaser if such defect exists. The determination of whether a product is defective shall be made by Warrantor in Warrantor’s sole and subjective discretion. The Purchaser must notify Warrantor prior to shipping any defective part. Warrantor, at its sole discretion, may cover expenses incurred in shipping the defective part to Warrantor for evaluation; provided, however, that Warrantor will not be responsible for labor, travel time, mileage, removal, installation or incidental or consequential damages. However, any part in excess of 140 pounds must be returned by the Purchaser, to the Warrantor’s nearest authorized facility at the Purchaser’s expense, if return is requested by Warrantor. Warrantor shall have a reasonable time within which to replace or repair the defective part. If Warrantor determines that the product is not defective under the terms of this warranty in Warrantor’s sole and subjective discretion, then Purchaser shall be responsible for any expenses incurred by Warrantor in returning the equipment to the Purchaser.

Limitations and Disclaimers of Other Warranties

EXCEPT FOR THE EXPRESS WARRANTY PROVISIONS STATED ABOVE, WARRANTOR DISCLAIMS ALL WARRANTIES, EXPRESS AND/OR IMPLIED, INCLUDING WITHOUT LIMITATION, THE IMPLIED WARRANTIES OF MERCHANTABILITY, AND FITNESS FOR A PARTICULAR PURPOSE, NONINFRINGEMENT AND TITLE. No representation or other affirmation of fact by representatives of Warrantor, whether verbal or in writing, including photographs, brochures, samples, models, or other sales aids, shall constitute a warranty or other basis for any legal action against Warrantor. There are no other representations, promises, agreements, covenants, warranties, guarantees, stipulations or conditions, express or implied, by Warrantor except as expressly set forth herein. THE ORIGINAL PURCHASER AND ANY INTENDED USER OR BENEFICIARY OF THIS EQUIPMENT, SHALL NOT BE ENTITLED TO RECOVER ANY INDIRECT, SPECIAL, PUNITIVE, EXEMPLARY, CONSEQUENTIAL, SPECIAL, OR INCIDENTAL DAMAGES OR LOSSES, INCLUDING BUT NOT LIMITED TO, DAMAGES OF LOST PRODUCTION, LOST REVENUE, LOST PRODUCT, LOST PROFITS, LOST BUSINESS, LOSS OF USE, LOSS OF GOODWILL, OR BUSINESS INTERRUPTION, FROM WARRANTOR FOR ANY REASON WHATSOEVER INCLUDING WITHOUT LIMITATION WARRANTY OR DEFECT IN THE PRODUCT REGARDLESS OF THE SOLE, JOINT AND/OR CONCURRENT NEGLIGENCE, BREACH OF CONTRACT, BREACH OF WARRANTY, STRICT LIABILITY IN TORT OR STATUTORY CLAIMS OR OTHER LEGAL FAULT OR RESPONSIBILITY OF EITHER WARRANTOR OR PURCHASER OR ITS EMPLOYEES OR AGENTS. Warrantor does not warrant that its equipment meets or complies with the requirements of any particular safety code or governmental requirements.

Defective items replaced under the terms of this warranty become the property of Warrantor.

Design Changes

Warrantor reserves the right to change the design of its products from time to time without notice and without obligation to make corresponding changes in or to its products previously manufactured.

Rights of Purchasers

The validity and effect of this limited warranty as well as its interpretation, operation and effect, shall be determined exclusively by the principles of law and equity of the State of Indiana, USA. This limited warranty gives Purchaser specific legal rights. Purchaser may also have other rights, which may vary from state to state. Some states may not allow limitations as to the duration of implied warranties or to the exclusion or limitation of incidental or consequential damages, so some of the limitations and exclusions detailed set forth above may not apply. In the event that any one or more of the provisions of this warranty shall be or become invalid, illegal or unenforceable in any respect, the validity, legality and enforceability of the remaining provisions of this warranty shall not be affected thereby.

Interpretations

This Warranty constitutes the entire warranty agreement between Warrantor and Purchaser and supersedes any prior understandings or agreements pertaining to the same subject matter. This warranty cannot be amended except in writing which refers to this warranty which is signed by both Warrantor and Purchaser.

SECTION 1 INTRODUCTION

1.1 About This Manual

This manual is to replace or to be used with all previous information received on the Wood-Mizer® HR300 Series Resaw. All future mailings will be an addition to or a revision of individual sections of this manual as we obtain new information.

The information and instructions given in this manual do not amend or extend the limited warranties for the equipment given at the time of purchase.

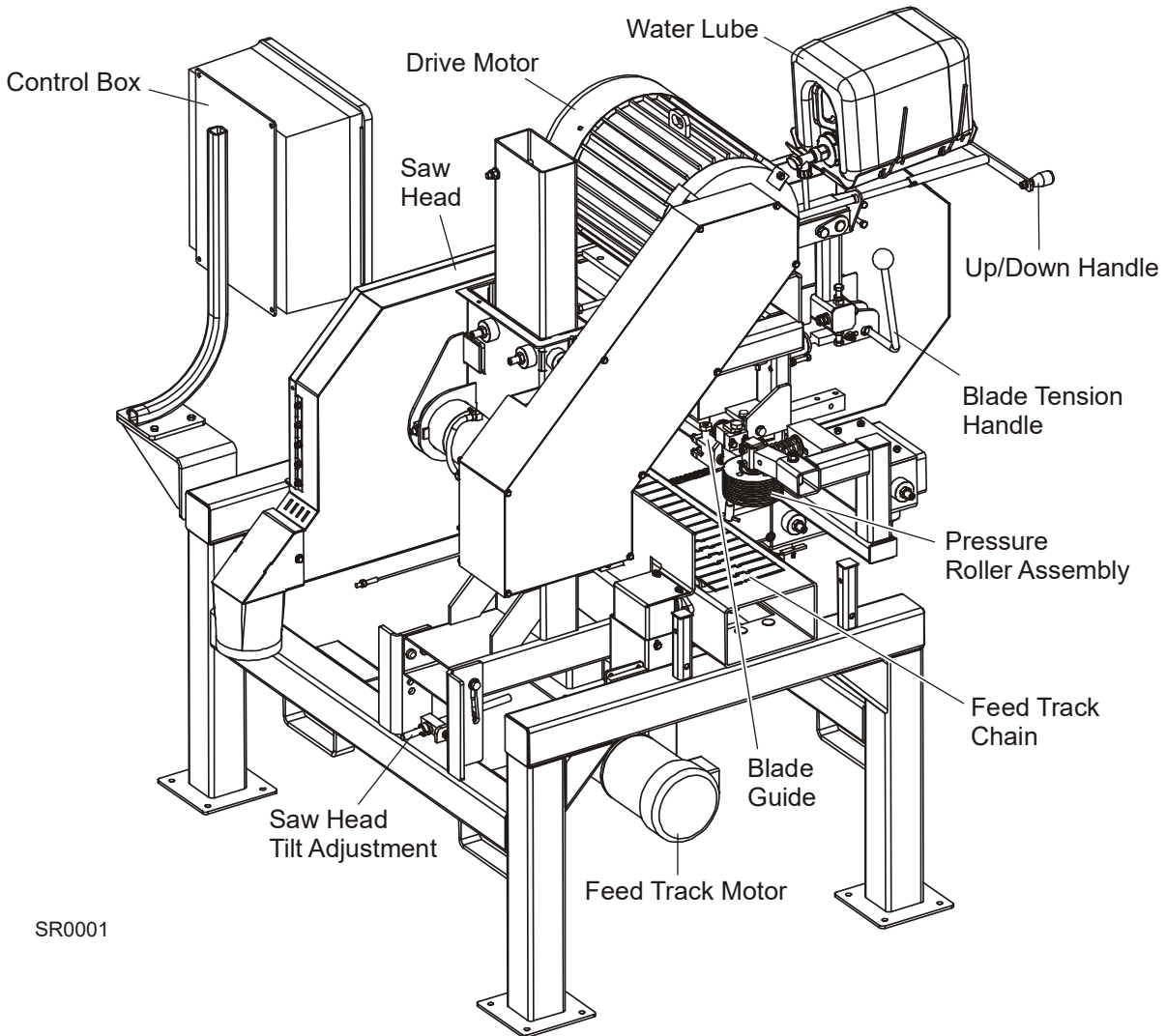

*.Wood-Mizer® is a registered trademark of Wood-Mizer Products, Inc.

1.2 Getting Service

Wood-Mizer is committed to providing you with the latest technology, best quality and strongest customer service available on the market today. We continually evaluate our customers' needs to ensure we're meeting current wood-processing demands. Your comments and suggestions are welcome.

General Contact Information

Toll free phone numbers are listed below for the *continental* U.S. and Canada. See the next page for contact information for more Wood-Mizer locations.

	United States	Canada
Sales	1-800-553-0182	1-877-866-0667
Service	1-800-525-8100	1-877-866-0667
Website	www.woodmizer.com	www.woodmizer.ca
E-mail	woodmizer@woodmizer.com	oninfo@woodmizer.com

Office Hours: All times are Eastern Standard Time.

Monday - Friday	Saturday (Indianapolis Office Only)	Sunday
8 a.m. to 5 p.m.	8 a.m. to 12 p.m.	Closed

Please have your vehicle identification number and your customer number ready when you call.

Wood-Mizer will accept these methods of payment:

- Visa, Mastercard, or Discover
- COD
- Prepayment
- Net 15 (with approved credit)

Be aware that shipping and handling charges may apply. Handling charges are based on size and quantity of order. In most cases, items will ship on the day they are ordered. Second Day and Next Day shipping are available at additional cost.

If your sawmill was purchased outside the United States or Canada, contact the distributor for service.

Wood-Mizer Locations

USA World Headquarters

Serving North & South America, Oceania, East Asia

Wood-Mizer LLC
8180 West 10th Street
Indianapolis, IN 46214

Phone: 317.271.1542 or 800.553.0182
Customer Service: 800.525.8100
Fax: 317.273.1011
Email: infocenter@woodmizer.com

Canadian Headquarters

Serving Canada

Wood-Mizer Canada
396 County Road 36, Unit B
Lindsay, ON K9V 4R3

Phone: 705.878.5255 or 877.357.3373
Fax: 705.878.5355
Email: ContactCanada@woodmizer.com

Brazil Headquarters

Serving Brazil

Wood-Mizer do Brasil
Rua Dom Pedro 1, No: 205 Bairro: Sao Jose
Ivoti/RS CEP:93.900-000

Tel: +55 51 9894-6461/ +55 21 8030-3338/ +55 51
3563-4784
Email: info@woodmizer.com.br

Europe Headquarters

Serving Europe, Africa, West Asia

Wood-Mizer Industries Sp z o.o.
Nagorna 114
62-600 Kolo, Poland

Phone: +48.63.26.26.000
Fax: +48.63.27.22.327

Branches & Authorized Sales Centers

For a complete list of dealers, visit www.woodmizer.com

1.3 Customer and Equipment Identification

An identification plate is located on the frame of the saw. The plate contains the serial number and configuration information of your machine. You will also receive a customer number when you purchase your machine.

These numbers will help expedite our service to you. Please locate them now and write them below so you have quick, easy access to them.

Identification Information (To be filled in by purchaser)

Model No. _____

Serial No. _____

Customer No. _____

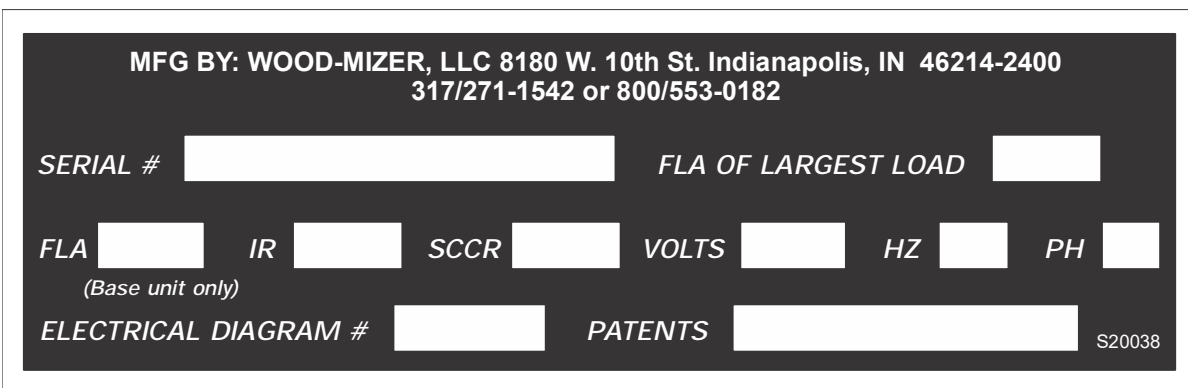

IDENTIFICATION PLATE

1.4 Dimensions

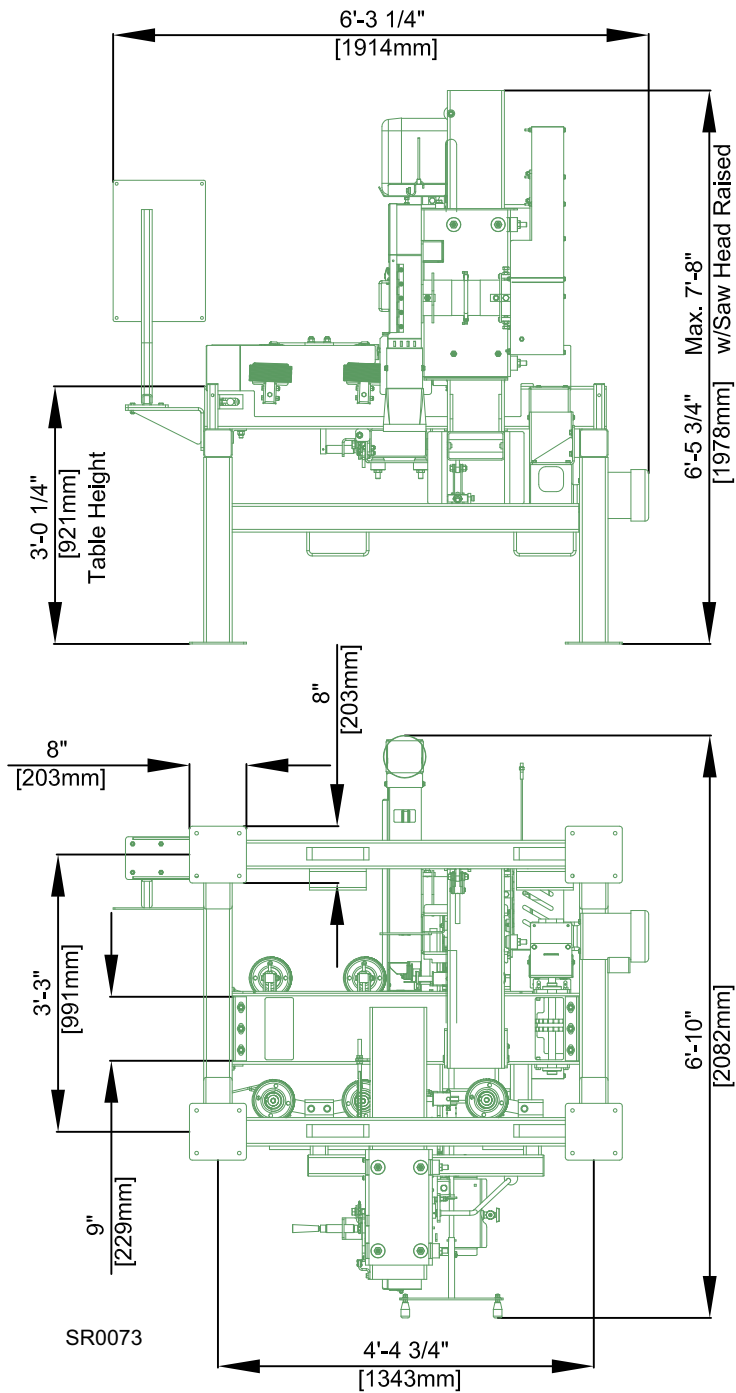

HR300 SERIES RESAW

HR300 SERIES RESAW W/OPTIONAL LOADING TABLES

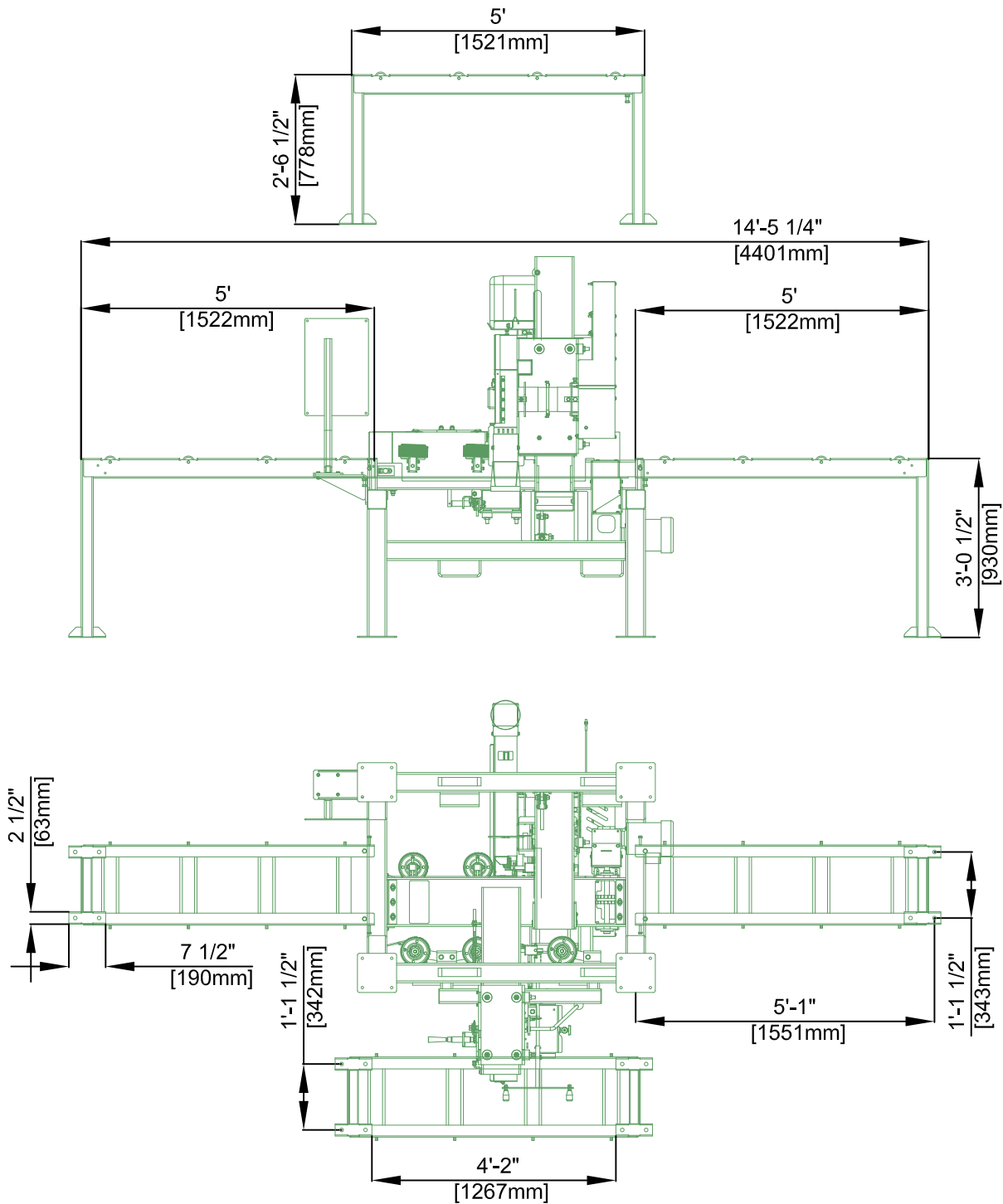

HR300 SERIES RESAW W/TABLES

1.5 Specifications

Model: HR300 Rev. A1.01+

Machine Dimensions:		Metric
Length: 76"		1930mm
Length w/Optional Loading Tables : 172 3/8"		4379mm
Width: 82"		2083mm
Minimum Width w/Optional Side Table: 102"		2591mm
Minimum Height: 78"		1981mm
Maximum Height (w/Saw Head Raised): 92"		2337mm
Table Height: 36 7/8"		937mm
Weight (Basic Unit): 1200 lbs		544kg

Material Dimensions:		
Minimum Cut Height: 1/4"		6.4mm
Maximum Cut Height: 10 1/2"		267mm
Maximum Material Height: 25"		635mm
Minimum Material Length: 18"		457mm
Maximum Material Length: Unlimited		
Minimum Material Width: 1"		25.4mm
Maximum Material Width: 10"		254mm

Feed System:		
Feed Rate: 0-100 Ft/Min		0-30m/min
Feed Motor Horsepower: 1		
Feed Motor RPM: 1725		

Blade:		
Length: 158"		
Standard Width: 1 1/4"		
Optional Width: 1 1/2"		
Profile: Many types available depending upon cutting needs		

Blade Motor:	EA10	EB20/EC20/EH20	EB25/EC25
Manufacturer:	Lincoln	Lincoln	Lincoln
Horsepower Rating:	10	20	25
Weight:	128 lbs.	287 lbs.	380 lbs.
Speed:	1745 RPM	1755 RPM	1775 RPM
Drive Belt:	3/5V800	3/5V800	3/5V800

Electrical Requirements:	HR300EA10-1	HR300EC20-1*	HR300EH20-1	HR300EB20-1	HR300EC25-1**	HR300EB25-1
Fused Disconnect:	100 Amps	60 Amps	60 Amps	100 Amps	60 Amps	100 Amps
Time Delay Fuse:	70 Amps	40 Amps	40 Amps	80 Amps	50 Amps	100 Amps
Suggested Wire Size:	6AWG	8AWG	8AWG	4AWG	8AWG	3AWG
FLA of Largest Load:	41.5	24.1	24.1	48.2	29.4	58.8
Machine FLA:	45.5	26.2	26.2	52.5	31.5	63
AIC/SCCR:	200K/5K	200K/5K	200K/5K	200K/5K	200K/5K	200K/5K
Volts/Hz/Phase:	230/60/1	460/50-60/3	380/50-60/3	230/50-60/3	460/50-60/3	230/50-60/3

*Use transformer kit 054930 for use with 575V

**Use transformer kit 054929 for use with 575V

HR300 SERIES RESAW SPECIFICATIONS

SECTION 2 SAFETY

2.1 Safety Symbols

The following symbols and signal words call your attention to instructions concerning your personal safety. Be sure to observe and follow these instructions.

 **DANGER!** indicates an imminently hazardous situation which, if not avoided, will result in death or serious injury.

 **WARNING!** suggests a potentially hazardous situation which, if not avoided, could result in death or serious injury.

 **CAUTION!** refers to potentially hazardous situations which, if not avoided, may result in minor or moderate injury or damage to equipment.



 **IMPORTANT!** indicates vital information.

NOTE: gives helpful information.

 Warning stripes are placed on areas where a single decal would be insufficient. To avoid serious injury, keep out of the path of any equipment marked with warning stripes.

2.2 Safety Instructions

NOTE: ONLY safety instructions regarding personal injury are listed in this section. Caution statements regarding only equipment damage appear where applicable throughout the manual.

 **WARNING!** Clean sawdust from all guards, vents, control boxes, or any area where sawdust may gather **after every shift**. Failure to do so may result in fire, causing death or serious injury. 

OBSERVE SAFETY INSTRUCTIONS

 **IMPORTANT!** Read the entire Owner's Manual before operating the HR300 Series Resaw. Take notice of all safety warnings throughout this manual and those posted on the machine. Keep this manual with this machine at all times, regardless of ownership.

Also read any additional manufacturer's manuals and observe any applicable safety instructions including dangers, warnings, and cautions.

Only persons who have read and understood the entire operator's manual should operate

the HR300 Series Resaw. The HR300 Series Resaw is not intended for use by or around children.

IMPORTANT! It is always the owner's responsibility to comply with all applicable federal, state and local laws, rules and regulations regarding the ownership and operation of your Wood-Mizer HR300 Series Resaw. All Wood-Mizer owners are encouraged to become thoroughly familiar with these applicable laws and comply with them fully while using the HR300 Series Resaw. 

WEAR SAFETY CLOTHING

 **WARNING!** Secure all loose clothing and jewelry before operating the resaw. Failure to do so may result in serious injury or death.

WARNING! Always wear gloves and eye protection when handling band-saw blades. Changing blades is safest when done by one person! Keep all other persons away from area when coiling, carrying or changing a blade. Failure to do so may result in serious injury.  

WARNING! Always wear eye, ear, respiration, and foot protection when operating or servicing the resaw. 

KEEP RESAW AND AREA AROUND RESAW CLEAN

 **DANGER!** Maintain a clean and clear path for all necessary movement around the resaw and lumber stacking areas. Failure to do so will result in serious injury.

HANDLE LUBRICANTS SAFELY

 **WARNING!** Use ONLY water with the water lube accessory. Never use flammable fuels or liquids. If these types of liquids are necessary to clean the blade, remove it and clean with a rag. Failure to do so may result in serious injury or death.

DISPOSE OF SAWING BY-PRODUCTS PROPERLY



IMPORTANT! Always properly dispose of all sawing by-products, including sawdust and other debris.

CHECK RESAW BEFORE OPERATION



DANGER! Make sure all guards and covers are in place and secured before operating the resaw. Failure to do so may result in serious injury.

Be sure the blade housing and pulley covers are in place and secure. Use the cover latch to secure blade housing covers.



WARNING! Check for proper rotation of the blade before operating the machine. Failure to do so may result in serious injury and/or machine damage.

WARNING! Always shut off the machine to stop the blade whenever the resaw is not in use. Failure to do so may result in serious injury.

WARNING! Do not for any reason adjust the drive belts with the machine running. Doing so may result in serious injury.

WARNING! Use both hands to operate the blade tensioner handle. Failure to do so may result in injury.

KEEP PERSONS AWAY



DANGER! Keep all persons out of the path of moving equipment and boards when operating the resaw. Failure to do so will result in serious injury.

KEEP HANDS AWAY



DANGER! Moving Parts Can Crush and Cut. Keep hands clear. Make sure all guards and covers are in place and secured before operating. Failure to do so may result in serious injury.

DANGER! Always keep hands away from moving bandsaw blade. Failure to do so will result in serious injury.

DANGER! Always be aware of and take proper protective measures against rotating shafts, pulleys, sprockets, etc. Always stay a safe distance from rotating members and make sure that loose clothing or long hair does not engage rotating members resulting in possible injury.

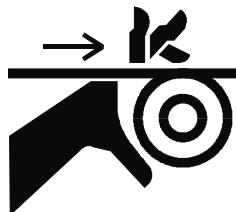

WARNING! Do not spin the blade wheels by hand. Spinning the blade wheels by hand may result in serious injury.

WARNING! Coastdown Required. Always shut down the resaw and allow all moving parts to come to a complete stop before removing any guards or covers. Do NOT operate with any guards or covers removed.

WARNING! Always keep clear of exiting sawdust. Keep hands, feet and any other objects away from the sawdust chute when operating resaw. Failure to do so may result in serious injury.

USE PROPER PROCEDURE WHEN CONDUCTING ELECTRICAL SAFETY CHECKS AND MAINTENANCE



DANGER! Make sure all electrical installation, service and/or maintenance work is performed by a qualified electrician and is in accordance with applicable electrical codes.

DANGER! ARC FLASH AND SHOCK HAZARD! Hazardous voltage inside the electric sawmill disconnect box, starter box, and at the motor can cause shock, burns, or death. Disconnect and lock out power supply before servicing! Keep all electrical component covers closed and securely fastened during resaw operation. Wear appropriate Personal Protection Equipment.

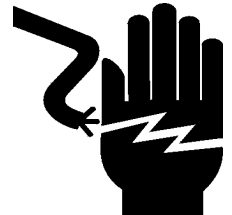

WARNING! Consider all electrical circuits energized and dangerous.

WARNING! Never assume or take the word of another person that the power is off; check it out and lock it out.

WARNING! Do not wear rings, watches, or other jewelry while working around an open electrical circuit.

WARNING! Remove the blade before performing any service to the motor or resaw. Failure to do so may result in serious injury.

DANGER! Lockout procedures must be used during:

- Changing or adjusting blades
- Unjamming operations
- Cleaning
- Mechanical repair
- Electrical maintenance
- Retrieval of tools/parts from work area

Activities where guards or electrical panel guard is open or removed

Maintenance hazards include:

Blade contact
Pinch points
Kickbacks
Missiles (thrown blades/wood chips)
Electrical

Failure to lockout may result in:

Cut
Crush
Blindness
Puncture
Serious injury and death
Amputation
Burn
Shock
Electrocution

To control maintenance dangers:

Lockout procedures must be followed (see ANSI Standard Z244.1-1982 and OSHA regulation 1910.147).

Never rely on machine stop control for maintenance safety (emergency stops, on/off buttons, interlocks).

Do not reach into moving blades or feed systems. Allow all coasting parts to come to a complete stop.

Electrical power supply and air supply must both be locked out.

Where established lockout procedures cannot be used (electrical troubleshooting or mechanical dynamic troubleshooting), alternative effective protective techniques shall be employed which may require special skills and planning.

Always follow safe operations practices in the workplace.

RESAW LOCKOUT PROCEDURE

Lockout procedures must be followed (see ANSI Standard Z244.1-1982 and OSHA regulation 1910.147).

Purpose:

This procedure establishes the minimum requirements for lockout of energy sources that could cause injury.

Responsibility:

The responsibility for seeing that this procedure is followed is binding upon all workers. All workers shall be instructed in the safety significance of the lockout procedure. It is your responsibility to ensure safe operation and maintenance of the machine.

Sequence of Lockout Procedure:

1. Notify all persons that a lockout is required and the reason therefore.
2. If the resaw is operating, shut it down by the normal stopping procedure.

3. Operate the switch so that the energy sources are disconnected or isolated from the resaw. Stored energy such as moving blades and feed system shall be dissipated.
4. Lockout the energy isolating devices with assigned individual locks.
5. After ensuring that no persons are exposed and as a check on having disconnected the energy sources, operate the push button or other normal operating controls to make certain the resaw will not operate. Caution: Return operating controls to neutral position after the test.
6. The resaw is now locked out.

Restoring Equipment to Service

1. When the job is complete and the resaw is ready for testing or normal service, check the resaw area to see that no one is exposed.
2. When the resaw is all clear, remove all locks. The energy isolating devices may be operated to restore energy to the resaw.

Procedure Involving More Than One Person

In the preceding steps, if more than one individual is required to lock out the resaw, each shall place his own personal lock on the energy isolating devices.

Rules for Using Lockout Procedure

The resaw shall be locked out to protect against accidental or inadvertent operation when such operation could cause injury to personnel. Do not attempt to operate any switch or valve bearing a lock.

Owner's Responsibility

The procedures listed in this manual may not include all ANSI, OSHA, or locally required safety procedures. It is the owner/operator's responsibility and not Wood-Mizer Products to ensure all operators are properly trained and informed of all safety protocols. Owner/Operators are responsible for following all safety procedures when operating and performing maintenance to the resaw.

KEEP SAFETY LABELS IN GOOD CONDITION



IMPORTANT! Always be sure that all safety decals are clean and readable. Replace all damaged safety decals to prevent personal injury or damage to the equipment. Contact your local distributor, or call your Customer Service Representative to order more decals.



IMPORTANT! If replacing a component which has a safety decal affixed to it, make sure the new component also has the safety decal affixed.

SECTION 3 SETUP AND OPERATION

3.1 Setup

Use a forklift or other appropriate equipment to move the resaw.



WARNING! Use extreme care and proper equipment to lift and move the resaw. Lift the machine from sides only, never from under the front or rear of the base or upper carriage. Failure to do so may result in personal injury and/or machine damage.

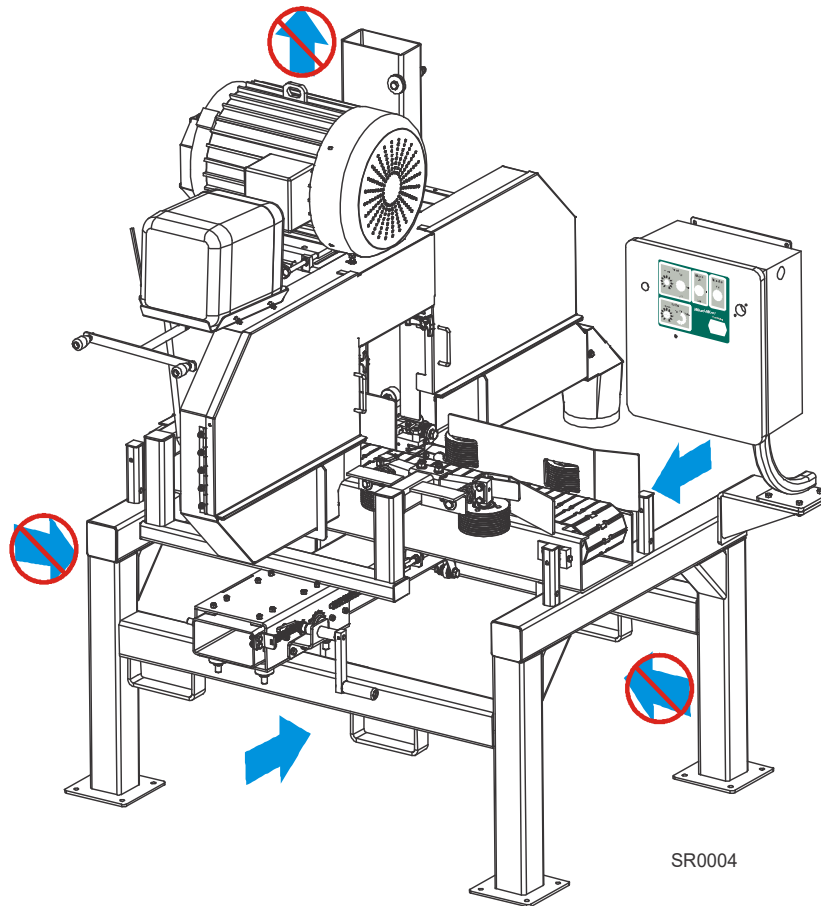

FIG. 3-1

Place the resaw on a concrete foundation strong enough to support the weight of the machine. Allow for room around the resaw to feed and remove material. Secure the resaw to the foundation with anchor bolts.

3.2 Electrical Installation



DANGER! Make sure all electrical installation, service and/or maintenance work is performed by a qualified electrician and is in accordance with applicable electrical codes.

DANGER! Hazardous voltage inside the electric control box and at the motor can cause shock, burns, or death. Disconnect and lock out power supply before servicing! Keep all electrical component covers closed and securely fastened during resaw operation.

The resaw identification plates including the required electrical information are shown below:

MFG BY: WOOD-MIZER LLC, 8180 W. 10th St. Indianapolis, IN 46214-2400
317/271-1542 or 800/553-0182

SERIAL # **HR300EA10-1 A1.00** FLA OF LARGEST LOAD **41.5**

FLA **45.5** IR **200kA** SCCR **5kA** VOLTS **240** HZ **60** PH **1**
(Base unit only)

ELECTRICAL DIAGRAM # PATENTS S20038

300_0003C

HR300EA10-1 IDENTIFICATION PLATE

MFG BY: WOOD-MIZER LLC, 8180 W. 10th St. Indianapolis, IN 46214-2400
317/271-1542 or 800/553-0182

SERIAL # **HR300EB20-1 A1.00** FLA OF LARGEST LOAD **48.2**

FLA **52.5** IR **200kA** SCCR **5kA** VOLTS **240** HZ **60** PH **3**
(Base unit only)

ELECTRICAL DIAGRAM # PATENTS S20038

300_0003C

HR300EB20-1 IDENTIFICATION PLATE

MFG BY: WOOD-MIZER LLC, 8180 W. 10th St. Indianapolis, IN 46214-2400
317/271-1542 or 800/553-0182

SERIAL # **HR300EB25-1 A1.00** FLA OF LARGEST LOAD **58.5**

FLA **63** IR **200kA** SCCR **5kA** VOLTS **240** HZ **60** PH **3**
(Base unit only)

ELECTRICAL DIAGRAM # PATENTS S20038

300_0003C

HR300EB25-1 IDENTIFICATION PLATE

MFG BY: WOOD-MIZER LLC, 8180 W. 10th St. Indianapolis, IN 46214-2400 317/271-1542 or 800/553-0182											
SERIAL #	HR300EC20-1	A1.00	FLA OF LARGEST LOAD	24.1							
FLA	26.2	IR	200kA	SCCR	5kA	VOLTS	480	HZ	60	PH	3
<i>(Base unit only)</i>											
ELECTRICAL DIAGRAM #	<input type="text"/>		PATENTS	<input type="text"/>			S20038				
300_0003C											

HR300EC20-1 IDENTIFICATION PLATE

MFG BY: WOOD-MIZER LLC, 8180 W. 10th St. Indianapolis, IN 46214-2400 317/271-1542 or 800/553-0182											
SERIAL #	HR300EC25-1	A1.00	FLA OF LARGEST LOAD	29.4							
FLA	31.5	IR	200kA	SCCR	5kA	VOLTS	480	HZ	60	PH	3
<i>(Base unit only)</i>											
ELECTRICAL DIAGRAM #	<input type="text"/>		PATENTS	<input type="text"/>			S20038				
300_0003C											

HR300EC25-1 IDENTIFICATION PLATE

MFG BY: WOOD-MIZER LLC, 8180 W. 10th St. Indianapolis, IN 46214-2400 317/271-1542 or 800/553-0182											
SERIAL #	HR300EH20-1	A1.00	FLA OF LARGEST LOAD	22.1							
FLA	24.2	IR	200kA	SCCR	5kA	VOLTS	480	HZ	60	PH	3
<i>(Base unit only)</i>											
ELECTRICAL DIAGRAM #	<input type="text"/>		PATENTS	<input type="text"/>			S20038				
300_0003C											

HR300EH20-1 IDENTIFICATION PLATE

IMPORTANT! The resaw is wired for use with a 240 or 480 volt power supply. To operate other power supplies an additional transformer is required. See the table below for transformers available from Wood-Mizer. All transformers are manufactured by Square D.

Conversion To	240 volts	400 volts	480 volts	600 volts
HR300EA10-1	N/A	N/A	N/A	N/A
HR300EB20-1	X	078212	X	078213
HR300EB25-1	X	078212	X	078213
HR300EC20-1	X	X	X	068047
HR300EC25-1	X	069616	X	068047
HR300EH20-1	X	X	X	X

TABLE 3-0

Perform the following steps prior to operating the resaw to make required electrical connections:

600V configuration only: Transformer can be purchased separately for the resaw (part no. 068047 for 25HP and part no. 068049 for 20HP).

1. Unlock and open the control box on the resaw.
2. Locate the main disconnecter in the upper right corner of the control box. Route the power supply cable through the control box side hole next to the disconnecter. Connect the power supply wires to the main disconnecter in the control box as shown below. **IMPORTANT!** If the blade motor runs backwards, switch any two of the three incoming high voltage wires connected to terminals L1, L2 or L3 to reverse the motor rotation.

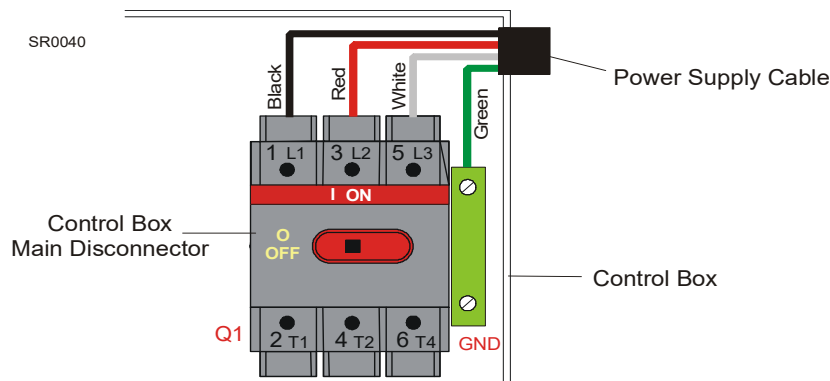

FIG. 3-2

3. Close and lock the resaw control box.
4. Check for proper rotation of the resaw blade. The infeed will always rotate the correct direction, but the blade rotation can be reversed. Push the MACHINE-ON button and then the BLADE-ON button. The blade should spin counterclockwise as viewed from the control side of the saw head. If the blade spins in the wrong direction, turn off the machine, disconnect and lockout the electrical power and check the wiring. [See SECTION 6](#) for electrical wiring diagrams.



WARNING! Check for proper rotation of the blade before operating the machine. Failure to do so may result in serious injury and/or machine damage.

3.3 Replacing The Blade



DANGER! Always disengage the blade and shut off the resaw motor before changing the blade. Failure to do so will result in serious injury.



WARNING! Always wear gloves and eye protection when handling bandsaw blades. Changing blades is safest when done by one person! Keep all other persons away from area when coiling, carrying or changing a blade. Failure to do so may result in serious injury.

Open the two blade housing covers that cover the blade wheels. Lower the hinged middle blade housing cover. Turn the blade tension handle to release the blade tension until the wheel is pulled in and the blade is lying loose in the blade housing. Lift the blade out of the blade housing.

When installing a blade, make sure the teeth are pointing the correct direction. The teeth should be pointing toward the infeed and sawdust chute sides of the resaw. Install the blade so it is lying around the wheels.

Position 1 1/4" wide blades on the wheels so the gullet is 1/8" (3.0 mm) out from the edge of the wheel. Position 1 1/2" wide blades on the wheels so the gullet is 3/16" (4.5 mm) out from the edge of the wheel.

Close the blade housing cover.

Next, turn the tension handle until the blade is tensioned correctly.

3.4 Tensioning The Blade

The blade tensioner is factory-set so proper blade tension is achieved when the rubber spring is compressed 1/4" (6.3 mm). An indicator bolt is provided to indicate when the rubber spring has been compressed properly. To tension the blade, turn the blade tension handle up until it locks in place.



WARNING! Use both hands to operate the blade tensioner handle. Failure to do so may result in injury.

Check the back side of the rubber spring washer is aligned with the indicator bolt head. If not, release the blade tension and turn the tensioner shaft counterclockwise to compress the rubber spring more; clockwise to compress the rubber spring less.

Use the scalloped disk to turn the tensioner shaft.

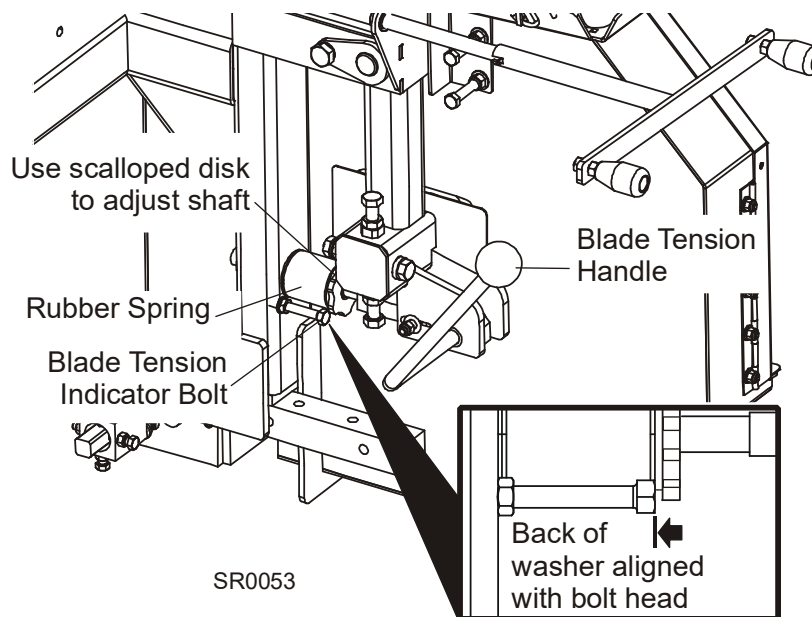

FIG. 3-3

Tension the blade and recheck the alignment of the rubber spring washer with the indicator bolt head.

Check the blade tension occasionally when adjusting the cant control or while cutting. As the blade and belts heat up and stretch, the blade tension will change. Adjust the tensioner shaft as necessary to maintain proper blade tension.

3.5 Tracking The Blade

1. Make sure the blade housing covers are closed and all persons are clear of the open side of the saw head.
2. Start the motor, rotating the blade until the blade positions itself on the wheels.

WARNING! Do not spin the blade wheels by hand. Spinning the blade wheels by hand may result in serious injury.

3. Turn off the motor, open the blade housing covers and check the position of the blade on the blade wheels.

Position 1 1/4" wide blades so the gullet is 1/8" (3.0 mm) out from the edge of the blade wheel ($\pm 1/16$ [1.5 mm])($\pm 1/32$ [.75 mm]). Position 1 1/2" blades so the gullet is 3/16" (4.5 mm) out from the edge of the blade wheel ($\pm 1/16$ [1.5 mm]).

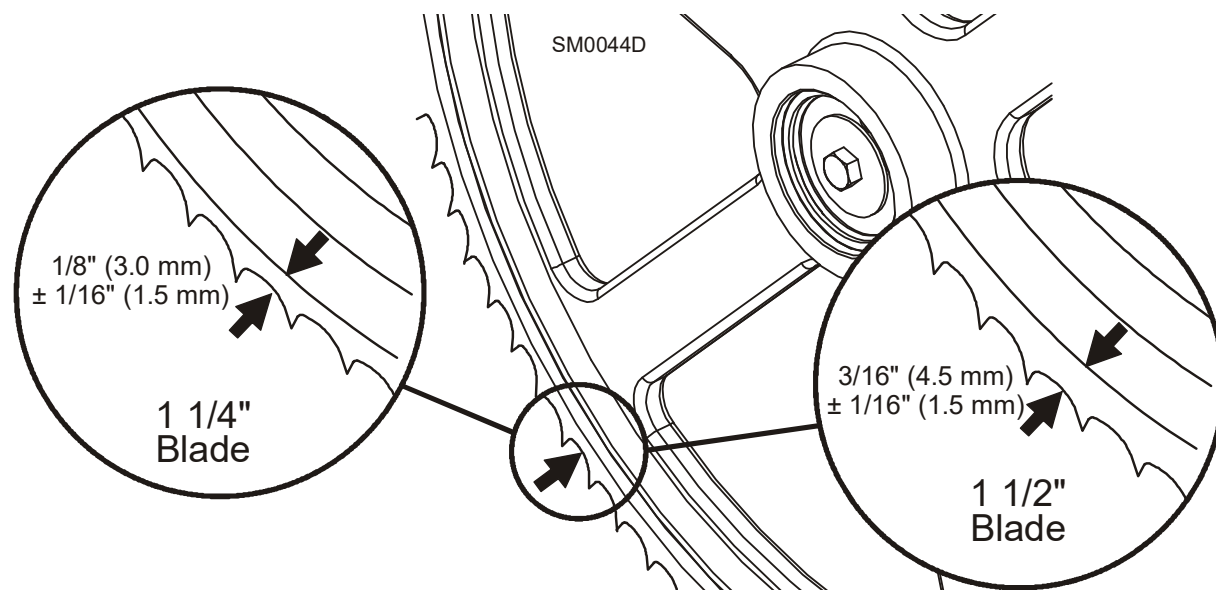

FIG. 3-4

To adjust where the blade travels on the blade wheels, use the cant control.

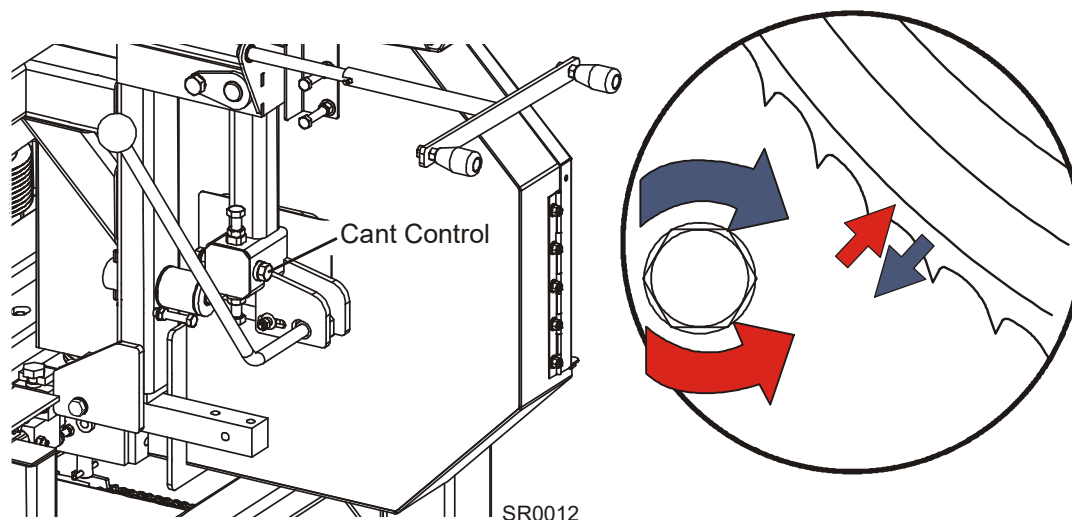

FIG. 3-4

If the blade is too far out, back the blade onto the wheel by turning the cant control counterclockwise. If the blade is too far in, turn the cant control clockwise until the gullet of the blade is the correct distance from the front edge of the wheel.

- Adjust the blade tension if necessary to compensate for any changes that may have occurred while adjusting the cant control.
- Close the blade housing covers.

DANGER! Make sure all guards and covers are in place and secured before operating the resaw. Failure to do so may result in serious injury. Be sure the blade housing and pulley covers are in place and secure.

IMPORTANT! After aligning the blade on the wheels, always double-check the blade guide spacing and location. ([See Section SECTION 5](#) for more information.)

3.6 Starting And Stopping The Machine

DANGER! Make sure all guards and covers are in place and secured before operating the resaw. Failure to do so may result in serious injury. Be sure the blade housing and pulley covers are in place and secure.

DANGER! Always be sure all persons are away from the resaw before starting the motor. Failure to do so will result in serious injury.

WARNING! Always wear eye, ear, respiration, and foot protection when operating the resaw. Failure to do so may result in serious injury.

- If necessary, release the MACHINE E-STOP button by turning it clockwise until it pops out.

The main control box has switches to start and stop resaw functions.

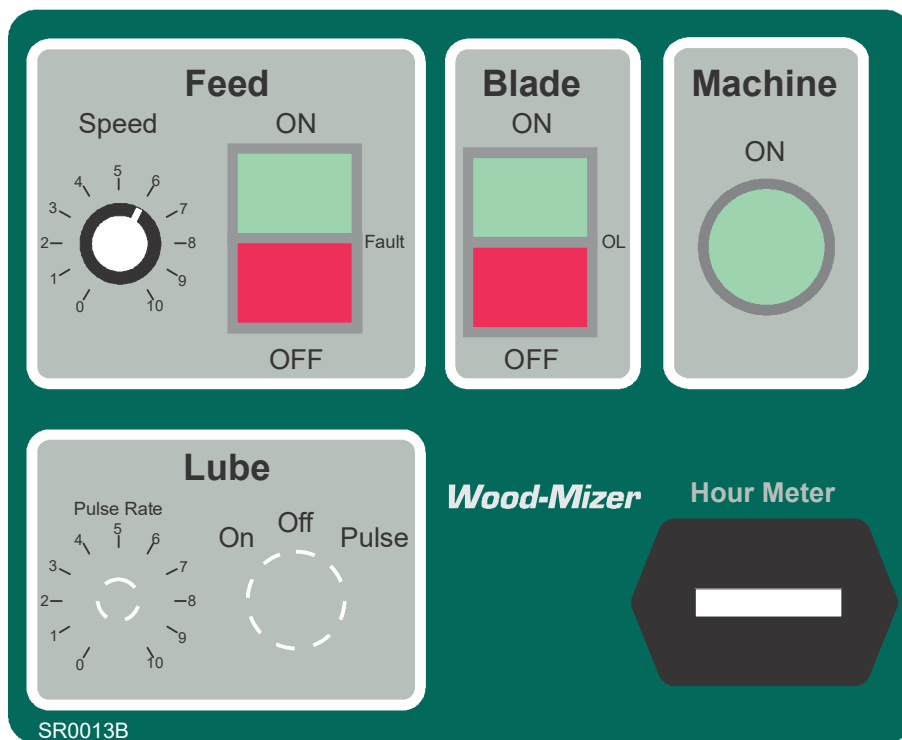

FIG. 3-0

- To turn the resaw power on, push the green MACHINE-ON button on the control box.
- Push the BLADE-ON button to start the resaw blade.

4. Push the FEED-ON button to start the resaw feed system.
5. Adjust the feed rate with the feed speed potentiometer. Turn the feed rate switch clockwise to increase the feed rate as desired. Maximum feed rate varies with width and hardness of the wood.

The switches on the control box can be used to shutdown the resaw.

1. Push the MACHINE-E-STOP button in an emergency to stop and shut down the resaw. This button must be released by turning clockwise before the resaw can be restarted.
2. Push the FEED-OFF or BLADE-OFF buttons to stop the corresponding functions without shutting down the machine.

3.7 Up/Down Operation

1. Install a blade, if needed, and check for correct blade tension. ([See Section 3.3](#)).
2. Set the saw head to the desired height. (The blade height scale shows the height of the blade above the feed chain.)



Use the up/down crank handle to raise or lower the saw head. Turn the handle clockwise to raise the saw head or counterclockwise to lower the saw head.

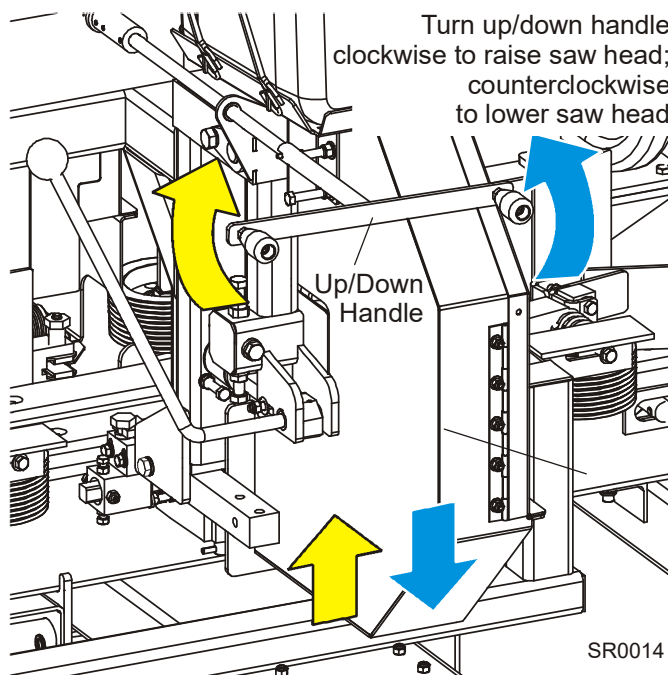

FIG. 3-1

3.8 Saw Head Tilt Adjustment

Use the tilt adjustment bolt to tilt the saw head as desired. Install the crank handle from the up/down system to the tilt adjustment bolts, if necessary. Remove the locking bolt from one of the tilt adjustment holes. Loosen the two bolts in the slotted holes. Turn the crank handle clockwise or counterclockwise to tilt the saw head as shown.

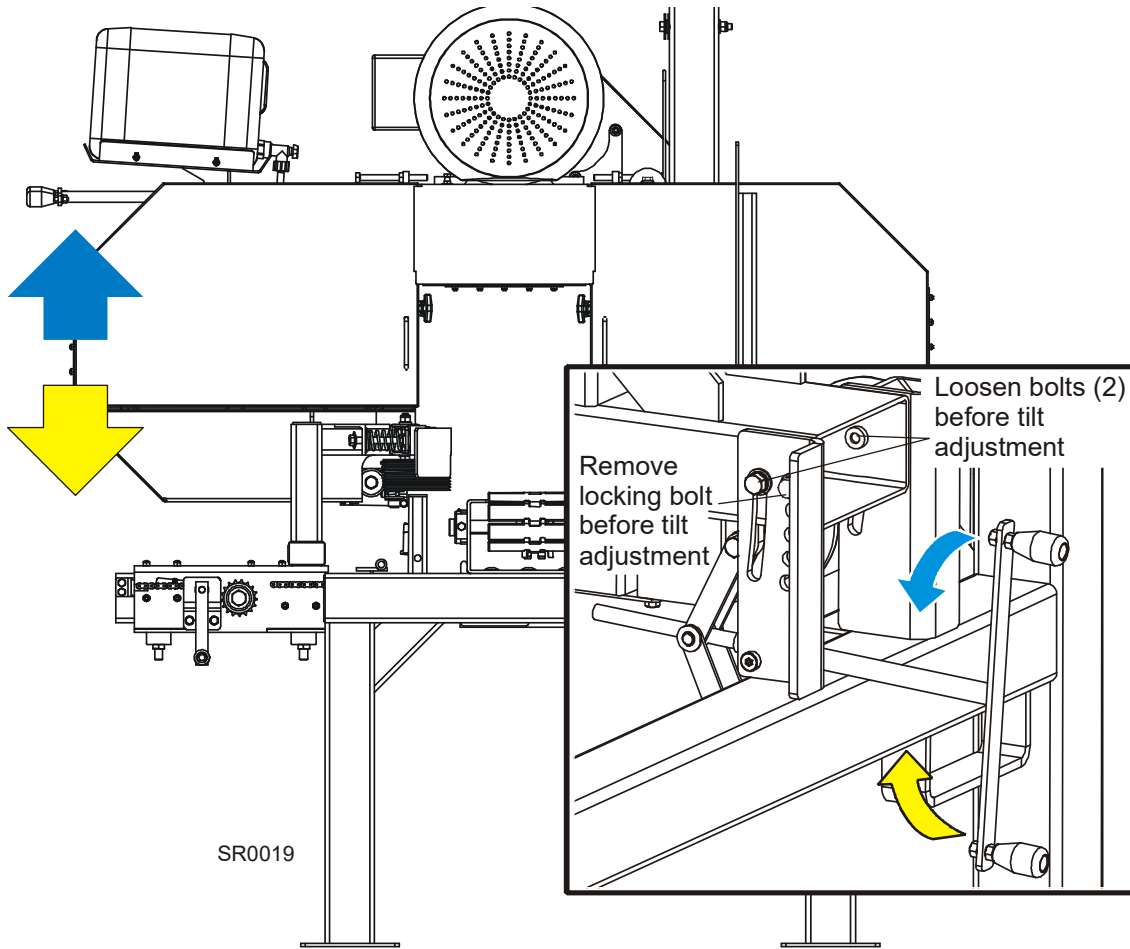

FIG. 3-2

Replace the locking bolt in the hole to secure the saw head in place as desired. **NOTE:** Each hole is an additional 2-degree saw head tilt. This allows to tilt the saw head up to 8 degrees.

Retighten the two bolts in the slotted holes when done to secure the saw head.

3.9 Pressure Roller Adjustment

Use the crank handle to move the pressure roller assembly in or out. Turn the crank handle clockwise to move the pressure rollers closer to the stationary rollers. Lift the sprocket lock and turn the crank handle counterclockwise to move the pressure rollers away from the stationary rollers.

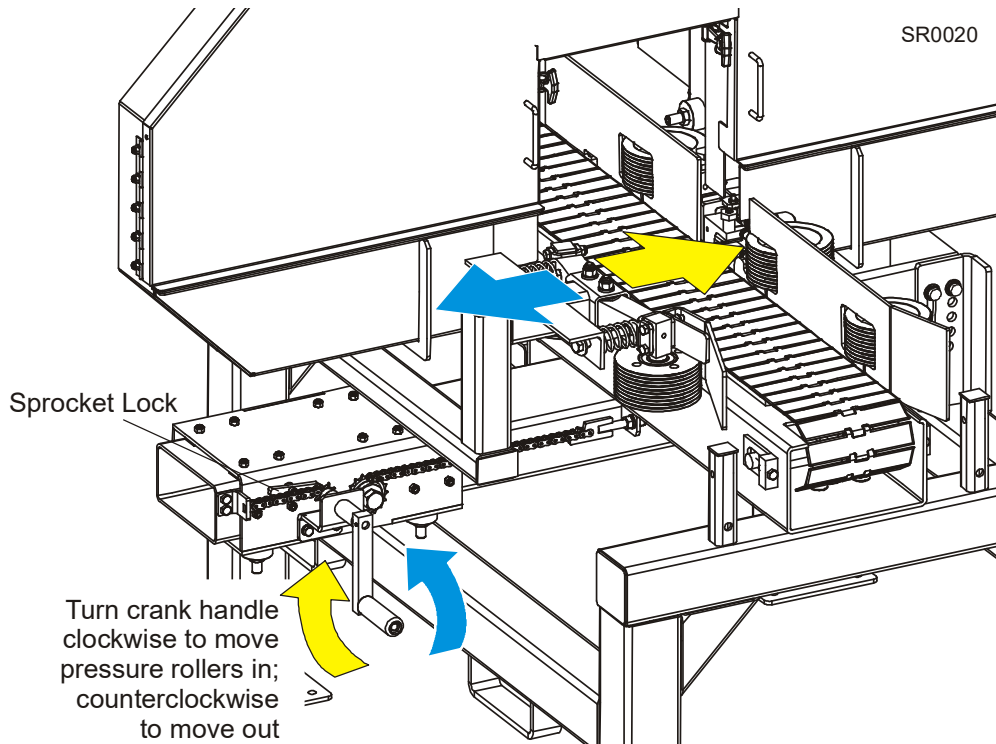

FIG. 3-3

Adjust the pressure roller assembly so its rollers are about 1" closer to the stationary rollers than the actual material width to be cut. This allows for the necessary pressure to be applied to feed the material into the feed system and make the cut.

3.10 Water Lube Operation

The Water Lube System keeps the blade clean. Water flows from a 5-gallon (18.9 liter) bottle through a hose to the blade guide where the blade enters the log. A valve in the bottle cap controls the amount of water flow.

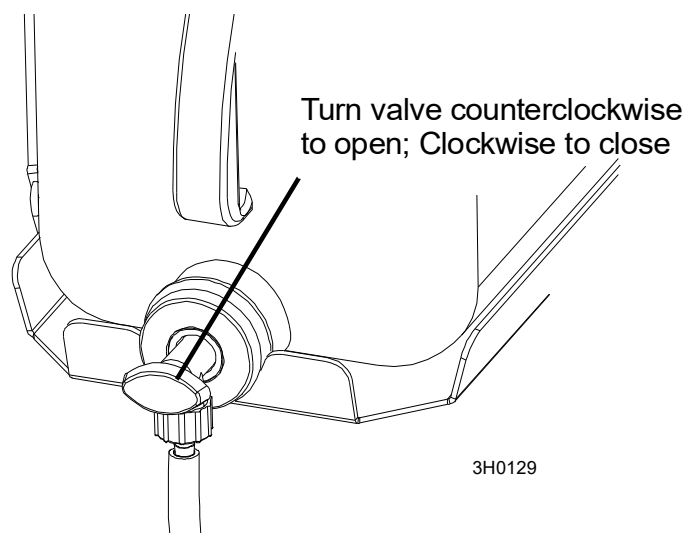

FIG. 3-4

Not all types of wood require the use of the Water Lube System. When it is needed, use just enough water to keep the blade clean. This saves water, and lowers the risk of staining the boards with water. Usual flow will be 1-2 gallons (3.8-7.6 liters) per hour.

Before removing the blade, let the blade spin with water running on it for about 15 seconds. This will clean the blade of sap buildup. Wipe the blade dry with a rag before storing or sharpening.

For further lubrication benefits, add one 12oz. bottle of Wood-Mizer Lube Additive to 5 gallons of water. Wood-Mizer Lube Additive enables some previously impossible timbers to be cut by significantly reducing resin buildup on the blade. It helps to reduce heat buildup, wavy cuts, and blade noise. This biodegradable and environmentally friendly pre-mix includes a water softener additive, so it works with hard water.



WARNING! Use ONLY water and Wood-Mizer Lube Additive with the water lube accessory. Never use flammable fuels or liquids such as diesel fuel. Failure to do so can damage the equipment and may result in serious injury or death.

If you are sawing in freezing temperatures, remove the water lube bottle from the resaw when done sawing and store it in a warm place. Blow any remaining water from the water lube hose.

If your resaw is equipped with the optional LubeMizer System, see the separate LubeMizer System manual for operation instructions.

3.11 The Lube-Mizer System (Optional)

This option is used in place of the standard Water Lube system to lubricate the blade during sawing. The Lube-Mizer option applies lubricant to both sides of the blade as you are sawing to reduce resin buildup on the blade. The system utilizes an automatic valve which activates the lubricant flow only when the blade is rotating. The Lube-Mizer control switches allow you to adjust the volume of lubricant for various wood types. The Lube-Mizer option uses less volume than the standard Water Lube, helping to reduce lubricant/sawdust mess and waste, and to prevent stained boards.

Usual flow will be between .07 and 2.5 gallons (2.6 - 9.5 liters) per hour.

1. To start the self-priming system,
 - Open the water lube bottle valve all the way.
 - Push the Blade-On button on the control box to start the blade.
 - Turn the lube control switch to PULSE* and set the lube dial to the desired flow rate. Use the lowest setting that successfully eliminates pitch buildup.
- NOTE:** Softwood applications will usually require more lubricant than hardwood applications.
2. Cut the material as normal.
3. To shut off the lube,
 - Turn the lube control switch to OFF.
 - Close the lube bottle valve all the way.

*.Pulse is suitable for most cutting applications. CONTINUOUS delivers a steady stream of lubricant and should be used only for heavy pitch buildup or occasional blade cleaning.

The lube controls are shown in the following graphic.



FIG. 3-0

- If you are sawing or storing the resaw in freezing temperatures, use windshield washer fluid to help prevent the water from freezing

CAUTION! Add windshield washer fluid to the water tank and prime as recommended when sawing or storing the resaw in below-freezing temperatures. Use windshield washer fluid with a freezing point of at least -20°F (-29°C). Failure to do so will cause damage to the Lube-Mizer system may result.

For further benefits, add one 12oz. bottle of Wood-Mizer Lube Additive to a 5 gallon jug of water. Wood-Mizer Lube Additive enables some previously impossible timbers to be cut by significantly reducing resin buildup on the blade. It helps to reduce heat buildup, wavy cuts, and blade noise. This biodegradable and environmentally friendly pre-mix includes a water softener additive, so it works with hard water.

WARNING! Use ONLY water, Wood-Mizer Lube Additive or windshield washer fluid with the water lube accessory. Never use flammable fuels or liquids such as diesel fuel. If these types of liquids are necessary to clean the blade, remove it and clean with a rag. Failure to do so can damage the equipment and may result in serious injury or death.

Use windshield washer fluid as an antifreeze to prevent the water from freezing and damaging the Lube-Mizer system. See the chart below for recommended mixture levels depending on the temperature where you are sawing or storing the resaw.

Run the Lube-Mizer system on the “Continuous” setting for 30 seconds after adding the windshield washer fluid to the system. This will insure the water throughout the system will not freeze and damage the check valves.

Ratio WWF ¹ :Water to fill 5 Gal. tank	Freezing Point Of Solution	
	(°F)	(°C)
5:0	-22	-30
4:1	-3	-19
3:2	7	-14

TABLE 3-0

2.5:2.5	13	-10
1:4	24	-4
0:5	32	0

TABLE 3-0

¹ WWF = Windshield Washer Fluid with -20°F (-29°C) freezing point.

A diagram showing the plumbing for the LMS system is provided for your reference.

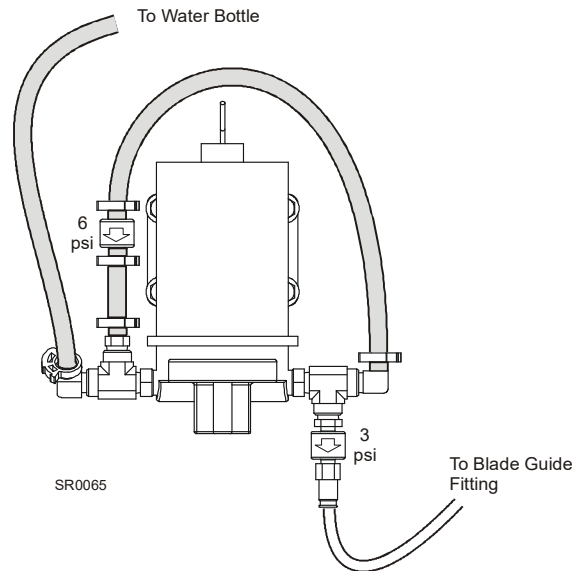

FIG. 3-1

3.12 Loading Tables Installation (Optional)

The resaw optional loading tables are available to provide assistance to operators to better handle the material. The Loading Table Assembly (Part No. 054464) includes two front/rear end tables and one side table. The front/rear tables are used to feed and pick up material by operators on both ends of the machine. The side table is provided to help transfer unfinished material to the front operator to proceed with another cut.



WARNING! Always disconnect and lockout power before performing any service to the resaw. Follow the lockout procedure provided in the safety section ([See Section 2.3](#)). Failure to do so may result in serious injury.

To install the loading tables to the resaw, perform the following steps:

1. Disconnect the power supply to the resaw and perform the lockout procedure.
2. Place both end tables next to the front and rear ends of the machine. Use the provided fasteners to secure the front and rear end tables to the resaw frame as shown.

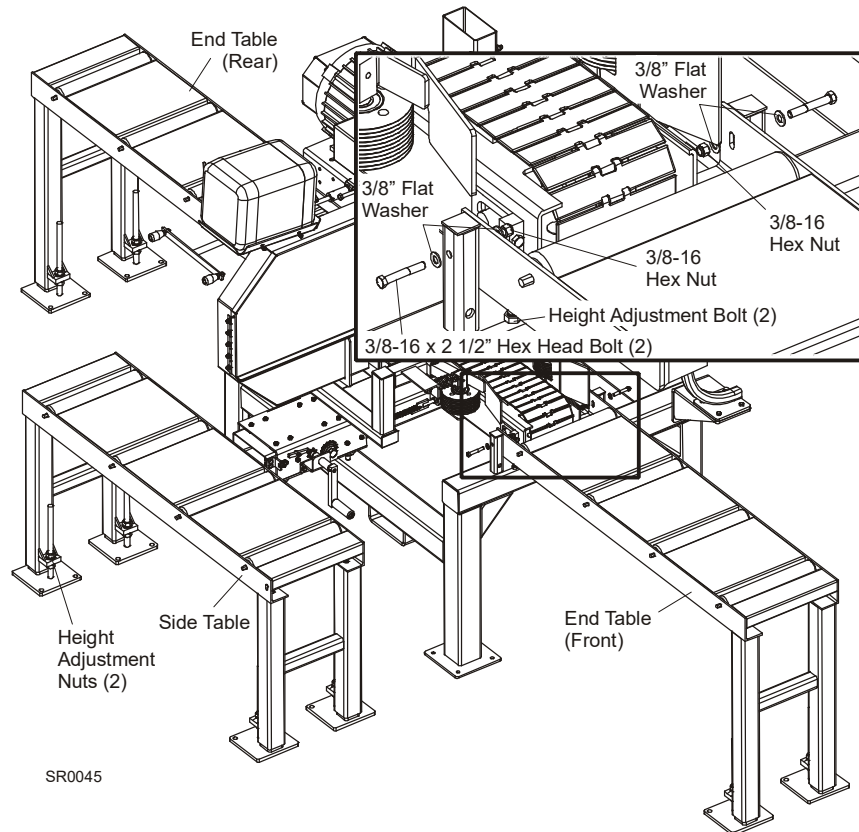

FIG. 3-2

3. Place the side table at the convenient location next to the resaw. Make sure the side table does not interfere with the main unit during operation.
4. Adjust the end and side tables as necessary. Use the height adjustment nuts at the bottom of the table legs to raise or lower the tables. Make sure the end tables and the feed track are level. Use the end tables adjustment bolts to raise or lower the other end of the end tables.

3.13 Pre-Operation Check

Prior to operating the resaw always perform these basic checks:

1. Make sure the resaw has been properly set up.
2. Make sure the motor drive belt is tensioned properly. [See Section 4.4](#) for more information.



WARNING! Do not for any reason adjust the motor drive belts with the motor running. Doing so may result in serious injury.

3. Be sure all guards and covers are in place and secured.



DANGER! Make sure all guards and covers are in place and secured before operating the resaw. Failure to do so may result in serious injury.

4. Also be aware that the blade is spinning whenever the motor is ON. You should always turn off the motor to stop the blade whenever the resaw is not in use and ensure that all parts have stopped moving before removing any covers or guards.



WARNING! Coastdown Required. Always shut off the motor and allow all moving parts to come to a complete stop before removing any guards or covers. Do NOT operate with any guards or covers removed.

WARNING! Always shut off the motor to stop the blade whenever the resaw is not in use. Failure to do so may result in serious injury.

5. An Emergency Stop is located on the resaw control box. Press the Emergency Stop to shut down the resaw. Before operating the resaw again, turn the E-Stop switch clockwise and release.



WARNING! Always disconnect and lockout power before performing any service to the resaw. Follow the lockout procedure provided in the safety section ([See Section 2.3](#)). Failure to do so may result in serious injury.

3.14 Operation Procedure



DANGER! Make sure all guards and covers are in place and secured before operating the resaw. Failure to do so may result in serious injury.

DANGER! Keep all persons out of the path of moving equipment and boards when operating the resaw or loading boards. Failure to do so will result in serious injury.

DANGER! Moving Parts Can Crush and Cut. Keep hands clear. Make sure all guards and covers are in place and secured before operating. Failure to do so may result in serious injury.

DANGER! Maintain a clean and clear path for all necessary movement around the resaw and lumber stacking areas. Failure to do so will result in serious injury.



WARNING! Always shut off the machine to stop the blade whenever the resaw is not in use. Failure to do so may result in serious injury.

WARNING! Always wear eye, ear, respiration, and foot protection when operating the resaw. Failure to do so may result in serious injury.

WARNING! Secure all loose clothing and jewelry before operating the resaw. Failure to do so may result in serious injury or death.

1. Install a blade, if necessary.
2. Tension the blade as described in Section 3.4 Tensioning The Blade.
3. Adjust the saw head height as described in Section 3.7 Up/Down Operation.
4. Adjust the saw head tilt as described in Section 3.8 Saw Head Tilt Adjustment.
5. Adjust the pressure roller assembly to the width of the material to be cut as described in Section 3.9 Pressure Roller Adjustment..
6. Perform the pre-operation check of the machine as described in Section 3.13 Pre-Operation Check.
7. Start the blade motor as described in Section 3.6 Starting And Stopping The Machine.
8. Use the feed rate potentiometer on the control box to set the feed track speed as desired.
9. Place the material on the feed track and push it into the pressure and stationary rollers. Use another piece of material to push it against the resaw blade. Make sure another person picks up the material on the other end of the resaw.
10. Repeat the above procedures for all boards to be cut.
11. Shutdown the machine when done cutting.

SECTION 4 MAINTENANCE

This section lists the maintenance procedures that need to be performed.

This symbol identifies the interval (hours of operation) at which each maintenance procedure should be performed.

Be sure to refer to option and engine manuals for other maintenance procedures.

4.1 Blade Guides



WARNING! Before performing service near moving parts such as blades, pulleys, motors, belts and chains, first turn the machine off. If the machine is turned on and moving parts activated, serious injury may result.

1. Check the rollers for performance and wear every blade change. Make sure the rollers are clean and spinning freely. If not, replace them. Replace any rollers which have worn smooth or have become cone shaped.
2. Make sure the blade screw in the top center of the C-frame is 1/16" (1.5 mm) away from the blade. If not, loosen the nut and adjust the screw as necessary. Check the screw every blade change. Failing to maintain this adjustment will lead to early blade breakage.

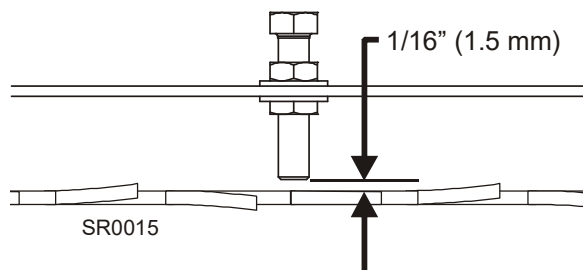

FIG. 4-1

High-Performance Guides Only:

3. Inspect the blocks at every blade change for damage or wear. If the block housing is bent or damaged, replace the block assembly. Also, replace the block assemblies before the blocks are worn to a point the blade may contact the block housing.
4. Check the guide blocks are properly spaced from the blade every 25 hours of operation. Use the provided shim or a feeler gauge to check the blocks are adjusted .008" - .010" from the blade.

As the blocks wear, the front inside corner will wear more than the body of the block. When the corner wears far enough, sawing performance will be affected even if the body of the block is adjusted properly to the blade. At this point, the block should be rotated or replaced. Rotate the blocks by switching their locations so the worn corner is located on the outside. If you have access to the appropriate equipment, you can also grind or mill the blocks to a new flat surface and reuse them. It is recommended you develop a routine schedule for replacing the blade guide blocks based on your sawing conditions and experience.

To adjust the top block up, loosen the clamp bolt and mounting bolt. Turn the adjustment bolt counterclockwise. Retighten the mounting bolt and clamp bolt.

To adjust the bottom block up, loosen the clamp bolt and mounting bolt. Use the provided adjustment tool to turn the adjustment screw clockwise. Retighten the mounting bolt and clamp bolt.



IMPORTANT! The blocks should be parallel to the blade. Check the space between the insert and the blade at each side of the insert to insure it is parallel. Use the appropriate outer adjustment bolt to tilt the insert mounting plate so the insert is parallel to the blade. [See Section 7.2](#) for instructions about checking and adjusting the assembly level with the blade.

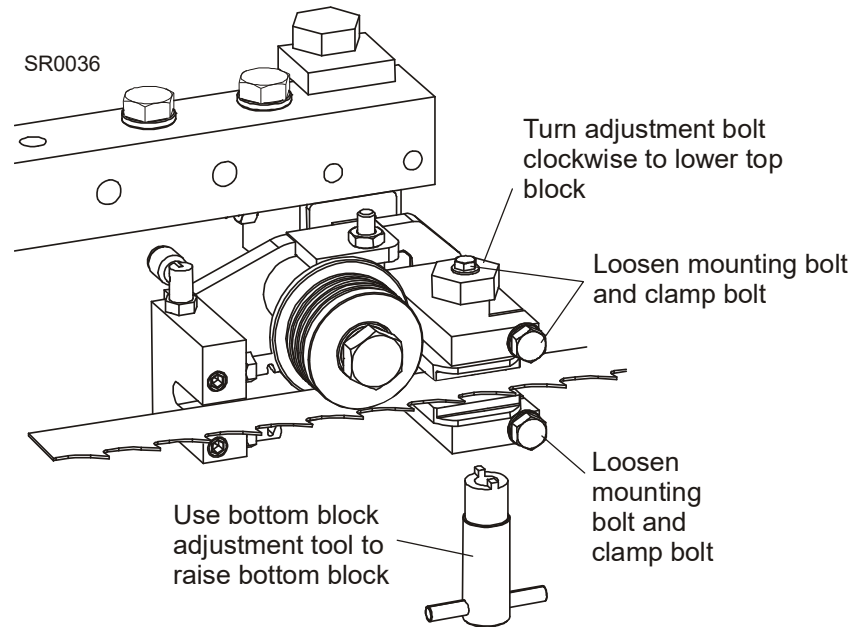

FIG. 4-1

Preventing sap buildup on the blade is critical when using the high-performance blade guide system. If the wood you are sawing leaves sap buildup using plain water in the blade lube system, use Wood-Mizer lube additive (4-Pak 60 oz. bottles part no. ADD-1).

4.2 Sawdust Removal



WARNING! Before performing service near moving parts such as blades, pulleys, motors, belts and chains, first turn the machine off and perform the lockout procedure. If the machine is turned on and moving parts activated, serious injury may result.

Remove the excess sawdust from the blade wheel housings and sawdust chute every blade change.



WARNING! Always keep clear of exiting sawdust. Keep hands, feet and any other objects away from the sawdust chute when operating resaw. Failure to do so may result in serious injury.

WARNING! Always check to ensure the steel fingers inside the sawdust chute are in place before operating the resaw. The steel fingers have been designed to help prevent a broken blade or some other object from becoming a projectile and exiting the sawdust chute. Failure to have these fingers in place may result in serious injury.

4.3 Blade Wheel Belts



WARNING! Before performing service near moving parts such as blades, pulleys, motors, belts and chains, first turn the machine off and perform the lockout procedure. If the machine is turned on and moving parts activated, serious injury may result.

Rotate the blade wheel belts and check them for wear. Rotating the belts every 50 hours will provide longer belt life. Replace belts as necessary. For maximum belt and blade performance use only B72.5 belts supplied by your nearest Wood-Mizer outlet.

4.4 Tensioning the Belts

DANGER! Coastdown Required. Always shut down the resaw and allow all moving parts to come to a complete stop before removing any guards or covers. Do NOT operate with any guards or covers removed.

WARNING! Always disconnect and lockout power before performing any service to the resaw. Follow the lockout procedure provided in the safety section ([See Section 2.3](#)). Failure to do so may result in serious injury.

WARNING! Do not for any reason adjust the motor drive belts with the motor running. Doing so may result in serious injury.

CAUTION! Never apply belt dressing as this will damage the belt and cause early failure.



Check the drive belt tension after the first 20 hours of operation, and every 50 hours thereafter.

To adjust the drive belt tension:

- Unbolt and remove the drive belt guard.
- Loosen the four motor mount bolts securing the motor to the motor mount.
- Use the left and right adjustment bolts as shown below to move the motor mount until the belt is tensioned properly (7/16" (11mm) deflection with 18 lbs. of deflection force).

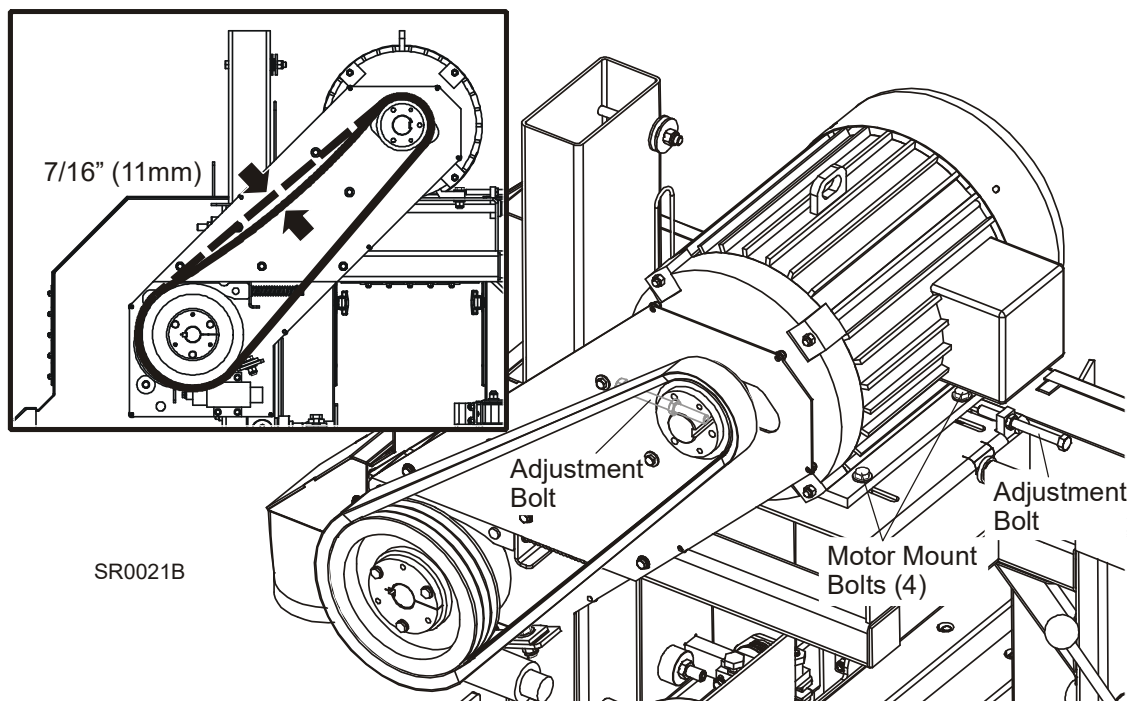

FIG. 4-2



CAUTION! Do not over tighten the drive belt as it can cause premature belt failure or damage to the drive belt bearings and motor.

CAUTION! Do not under-tighten the drive belt as it can cause the slippage of the belt on the drive pulleys.

- Retighten the four motor mount bolts when tension adjustment is complete.
- Retighten the left and right adjustment bolts to secure the motor mount in place.
- Close and secure the drive belt guard.

Periodically check the drive belt for wear. Replace any damaged or worn belts as needed.

4.5 Tensioning the Chains

DANGER! Coastdown Required. Always shut down the resaw and allow all moving parts to come to a complete stop before removing any guards or covers. Do NOT operate with any guards or covers removed.

WARNING! Always disconnect and lockout power before performing any service to the resaw. Follow the lockout procedure provided in the safety section ([See Section 2.3](#)). Failure to do so may result in serious injury.

To tension the feed track, use the two bolts and nuts at the operator end of the resaw. Do not overtension the feed track.

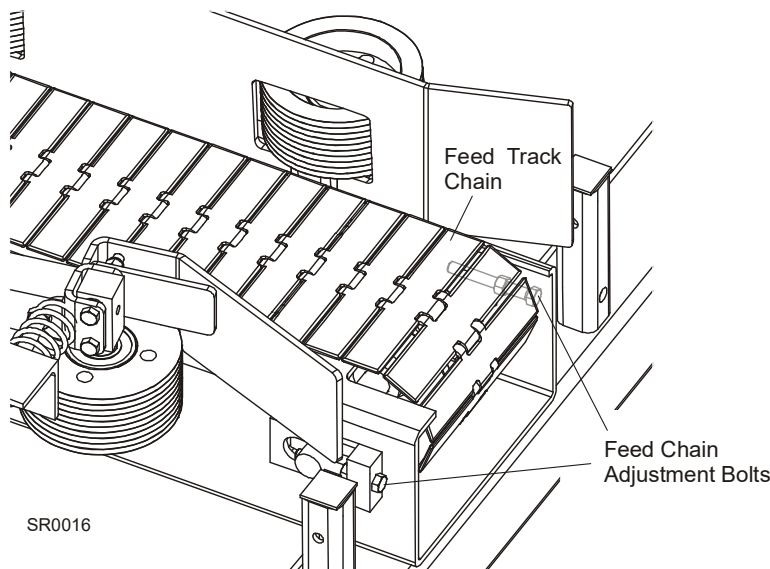

FIG. 4-3

To tension the pressure roller chain, loosen the tensioner nuts and adjust the chain tension as needed.

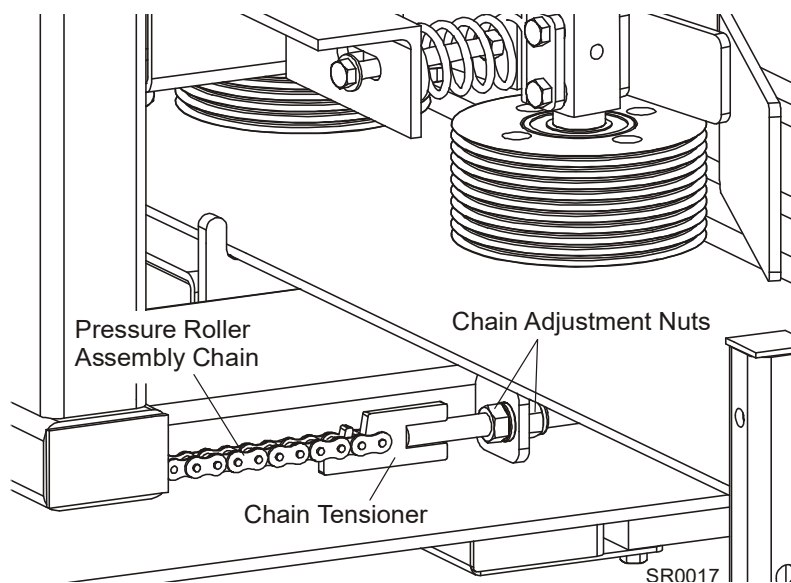

FIG. 4-4

To tension the feed motor chain, use the four adjustment nuts securing the gearbox to the resaw frame and two nuts on the chain housing. Do not overtension.

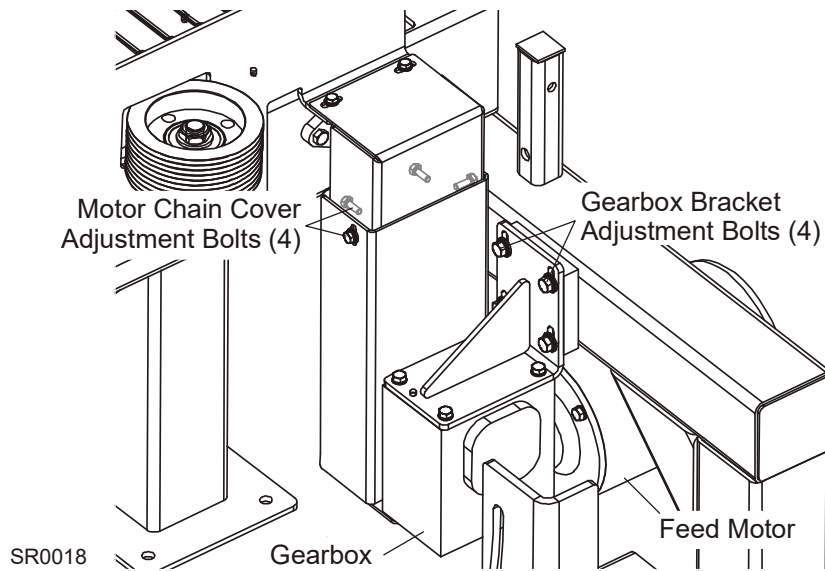

FIG. 4-5

4.6 Drive Bearing



WARNING! Before performing service near moving parts such as blades, pulleys, motors, belts and chains, first turn the machine off and perform the lockout procedure. If the machine is turned on and moving parts activated, serious injury may result.

Drain and refill the fluid in the drive-side cylinder bearing housing every 500 hours of operation.

Disconnect the oil level view hose from the fitting at the top of the bearing housing. With the fitting at the bottom of the bearing housing still connected, allow oil to drain from the oil level view hose. Once drained, pour fresh Automatic Transmission Fluid (ATF) such as Dexron III ATF into the hose until the oil level is in the acceptable range as indicated on the gauge decal. Reconnect the hose to the top fitting.

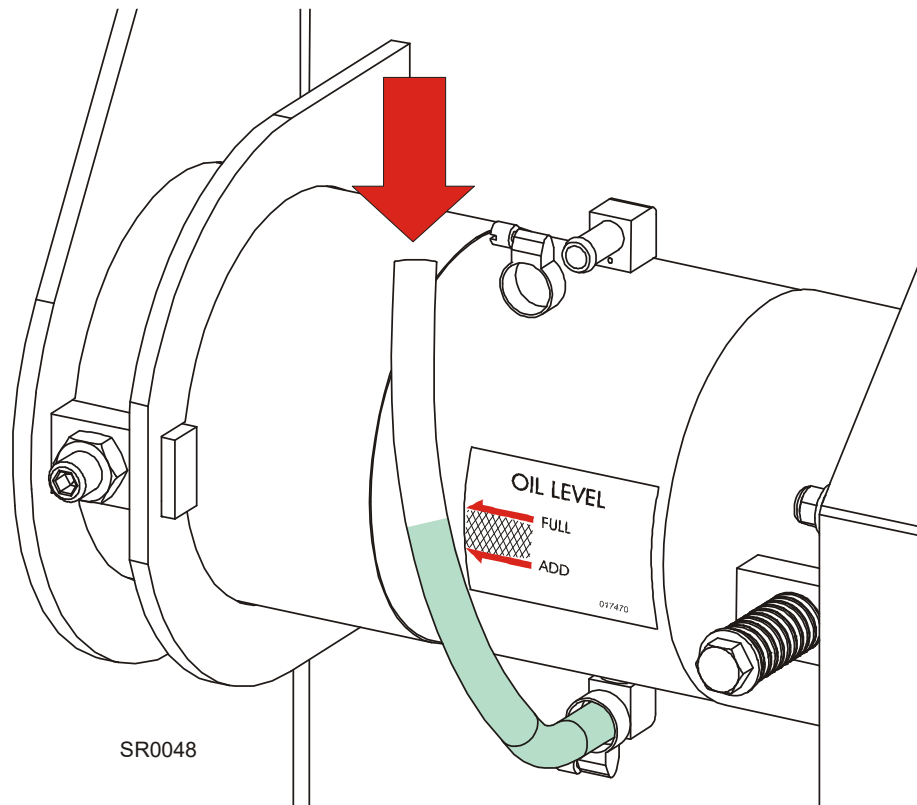

FIG. 4-6

4.7 Checking the Rollers

1. Check the feed rollers every 8 hours of operation. Remove any dirt or debris from the rollers. Make sure they spin freely, without much play.

4.8 Miscellaneous



WARNING! Before performing service near moving parts such as blades, pulleys, motors, belts and chains, first turn the machine off and perform the lockout procedure. If the machine is turned on and moving parts activated, serious injury may result.

1. Oil all chains with Dexron III ATF every fifty hours of operation.



CAUTION! Do not use chain lube. It causes sawdust buildup in chain links.

2. Check the resaw alignment every setup.
3. Grease the up/down screw under the motor mount bracket with a NLGI No. 2 grade lithium grease as needed.
4. Lubricate the saw head tilt screw threads with a NLGI No. 2 grade lithium grease as needed.
5. Grease the feed track bearings with a NLGI No. 2 grade lithium grease every fifty hours of operation.
6. Make sure all safety warning decals are readable. Remove sawdust and dirt. Replace any damaged or unreadable decals immediately. Order decals from your Customer Service Representative.
7. Check the feed track gearbox oil level. Add a synthetic gear oil such as Mobil SHC 634 as needed.

Drain and refill the gearbox with 24 ounces of oil after the first 2500 hours of resaw operation or after six months, whichever comes first. Repeat every 5000 hours or once a year, whichever comes first.

Wood-Mizer offers replacement gear oil in 8 ounce bottles (3 required for complete oil replacement).

4.9 Lube-Mizer (Optional)



DANGER! Hazardous voltage inside the electric control box and at the motor can cause shock, burns, or death. Disconnect and lock out power supply before servicing! Keep all electrical component covers closed and securely fastened during resaw operation.

Periodically check lube hoses and lines for buildup. Remove and flush with water as needed.

SECTION 5 ALIGNMENT

The Wood-Mizer resaw is factory aligned. The resaw alignment should be performed as necessary or approximately every 1500 hours of operation to solve sawing problems not related to blade performance.

5.1 Alignment Procedure

Blade Wheel Alignment

The blade wheels should be adjusted so they are level in the vertical and horizontal planes. If the blade wheels are tilted up or down, the blade will want to travel in the tilted direction. If the blade wheels are tilted horizontally, the blade will not track properly on the wheels.

1. Use the blade guide alignment tool to check the vertical alignment of each blade wheel. Attach the tool to the blade near the inner blade guide mount. Be sure the tool does not rest on a tooth or burr, and is lying flat against the bottom of the blade.

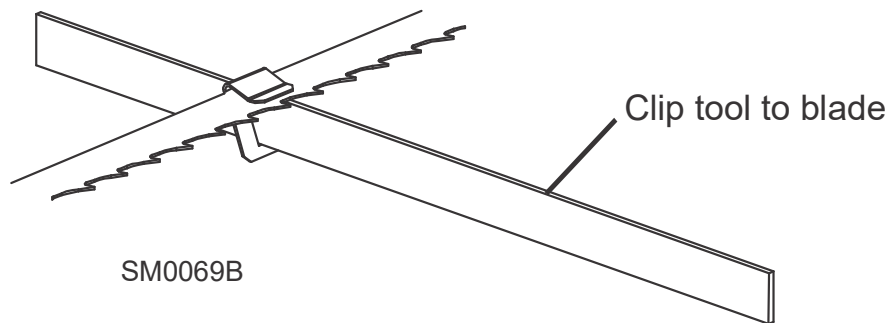
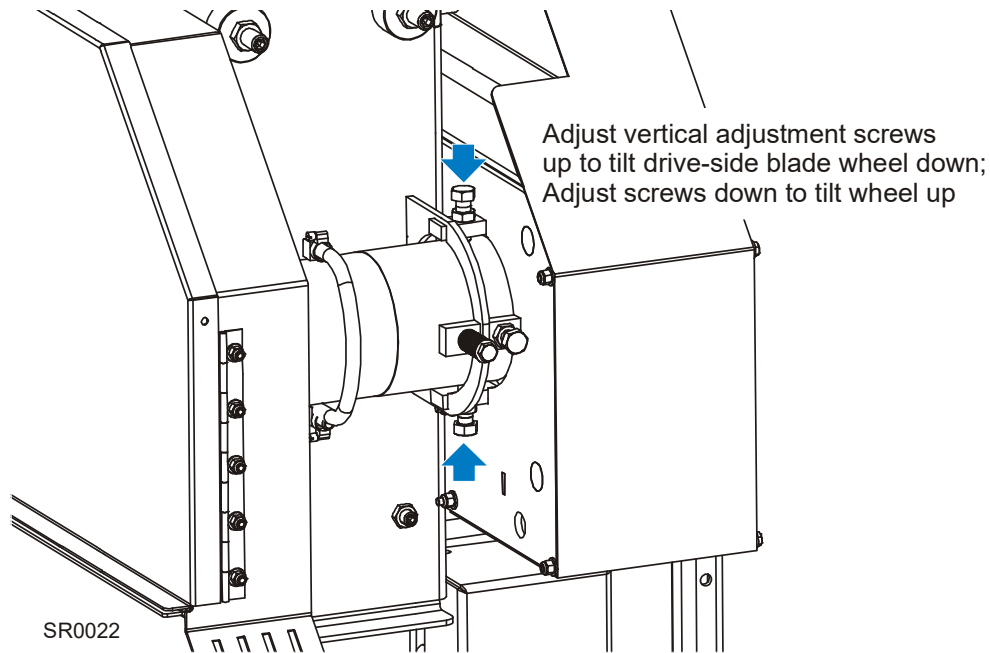

FIG. 5-1

2. Measure from the bottom of the tool front end to the top surface of the resaw feed track.
3. Measure from the bottom of the tool rear end to the top surface of the feed track.
4. If the two measurements differ by more than 1/16" (1.5 mm), adjust the vertical tilt of the drive-side blade wheel.

Use the vertical adjustment screws to adjust the drive-side blade wheel. To tilt the wheel down, loosen the top adjustment screw one quarter turn. Loosen the jam nut on the bottom adjustment screw and tighten the screw. Tighten the top and bottom jam nuts.

To tilt the wheel up, loosen the bottom adjustment screw one quarter turn. Loosen the jam nut on the top adjustment screw and tighten the screw. Tighten the top and bottom jam nuts.

**FIG. 5-2**

5. Recheck the vertical tilt of the drive-side blade wheel with the blade guide alignment tool. Readjust the blade wheel as necessary until the front and rear of the tool are the same distance from the feed track (within 1/16" [1.5 mm]). Readjust the drive belt tension as necessary.
6. Remove the tool from the blade and reattach it near the outer blade guide assembly.
7. Measure from the tool to the feed track at both ends of the tool. If the measurements at the front and rear ends of the tool differ by more than 1/16" (1.5 mm), adjust the vertical tilt of the idle-side blade wheel.

Use the vertical adjustment screws to adjust the idle-side blade wheel. To tilt the wheel up, loosen the bottom adjustment screw one quarter turn. Loosen the jam nut on the top adjustment screw and tighten the screw. Tighten the top and bottom jam nuts.

To tilt the wheel down, loosen the top adjustment screw one quarter turn. Loosen the jam nut on the bottom adjustment screw and tighten the screw. Tighten the top and bottom jam nuts.

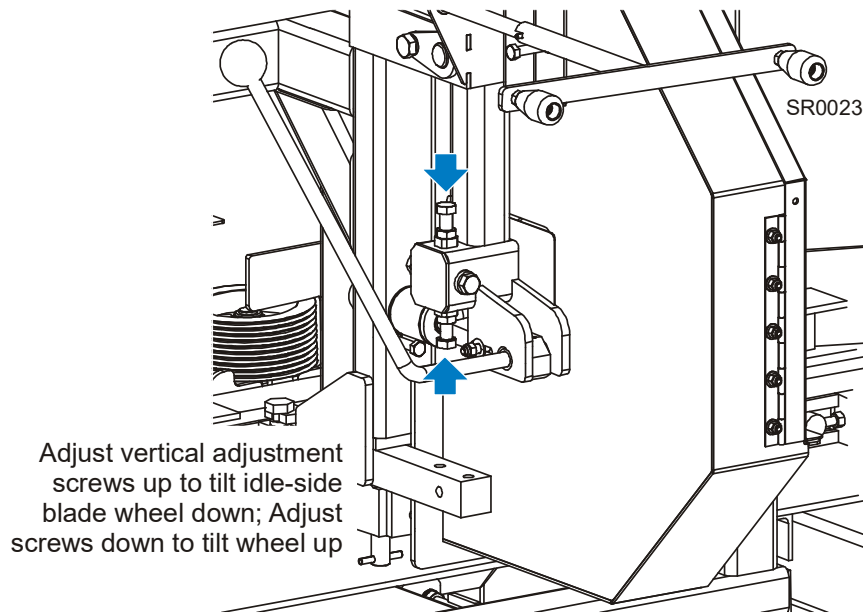

FIG. 5-3

8. Recheck the vertical tilt of the idle-side blade wheel with the blade guide alignment tool. Readjust the blade wheel as necessary until the front and rear of the tool are the same distance from the resaw feed track (within 1/16" [1.5 mm]).
9. Check the position of the blade on the idle-side blade wheel.

The horizontal tilt of the blade wheel should be adjusted so that the gullet of an 1-1/4" blade is 1/8" (3 mm) out from the front edge of the wheel ($\pm 1/32$ [0.75 mm])($\pm 1/16$ [1.5 mm]). The gullet of an 1-1/2" blade should be 3/16" (4.5 mm) out from the front edge of the wheel ($\pm 1/16$ [1.5 mm]). Do not let the teeth ride on the wheels.

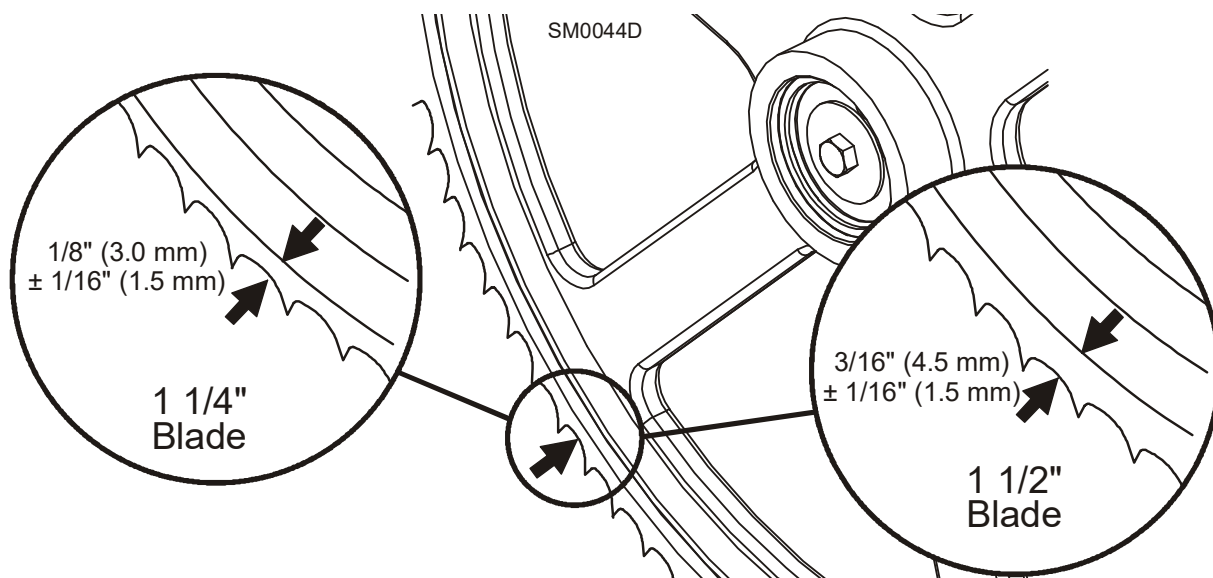

FIG. 5-4

Use the cant control adjustment to adjust the idle-side blade wheel. If the blade is too far forward on the wheel, turn the cant control counterclockwise. If it is too far back on the wheel, turn the cant control clockwise.

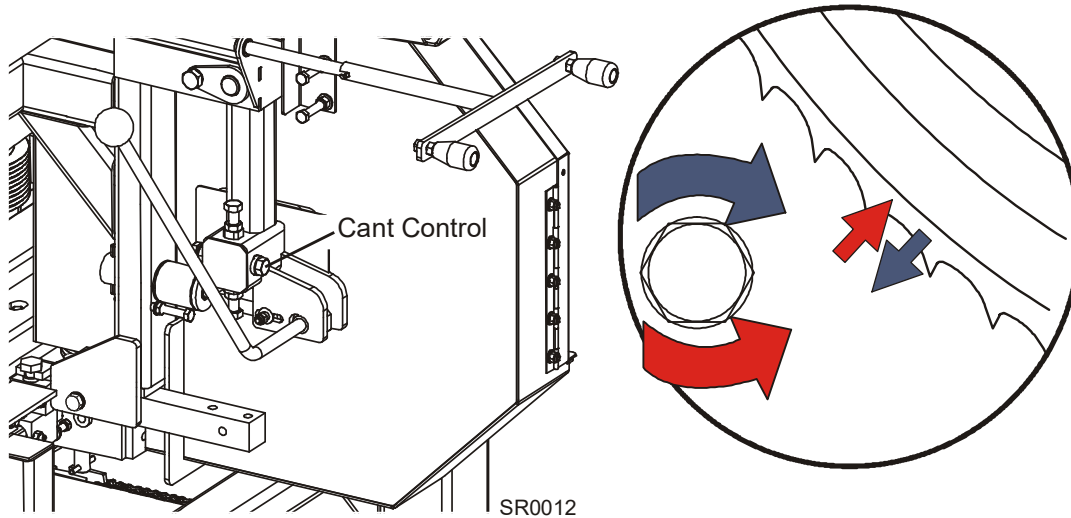

FIG. 5-4

10. Check the position of the blade on the drive-side blade wheel. The blade should be positioned on the wheel as described for the idle-side blade wheel. Adjust the drive-side blade wheel if necessary.

Use the horizontal adjustment screw to adjust the drive-side blade wheel. Loosen the top vertical screw to allow movement of the drive shaft. To move the blade back on the wheel, loosen the jam nut and turn the horizontal adjustment screw clockwise one quarter turn.

To move the blade out on the wheel, loosen the jam nut and turn the horizontal adjustment screw counterclockwise one quarter turn.

Repeat adjustments in quarter-turn increments until the blade tracks properly on the drive-side blade wheel. Tighten the horizontal adjustment screw jam nut and the top vertical screw.

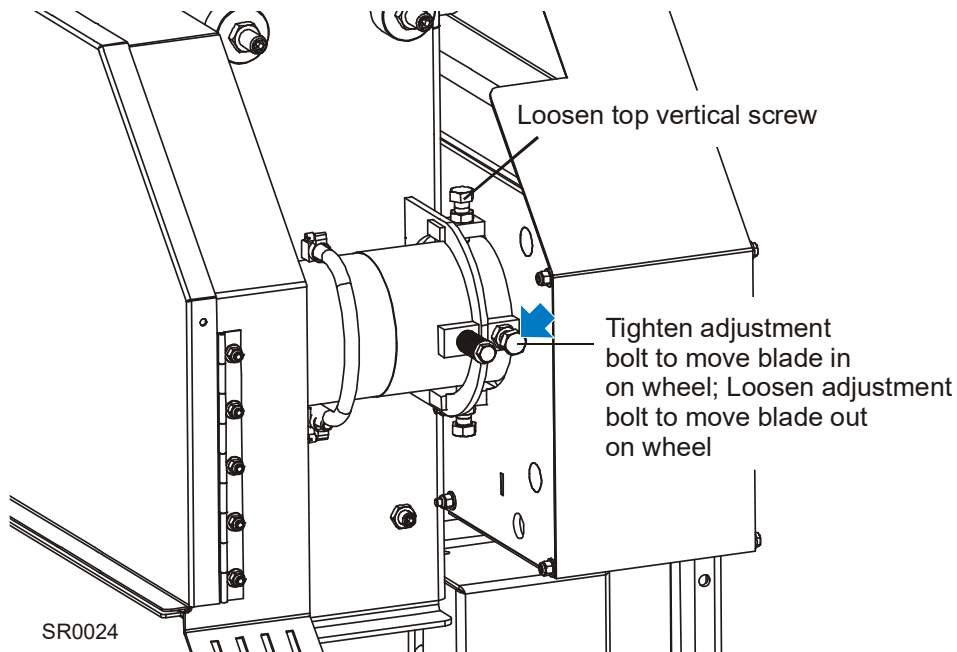

FIG. 5-5

Saw Head Adjustment

Making these adjustments correctly will insure the saw head cuts smoothly and blade will remain parallel with the feed track.

To adjust the saw head tilt, use the upper and lower horizontal adjustment screws. To raise or lower the outside of the saw head, loosen the two upper and lower adjustment nuts. Use the screws to adjust the saw head tilt as shown. Recheck the measurement from the blade to the feed track and adjust the upper and lower horizontal adjustment screws until the outside of the saw head is parallel with the feed track. Tighten the upper and lower adjustment nuts when finished.

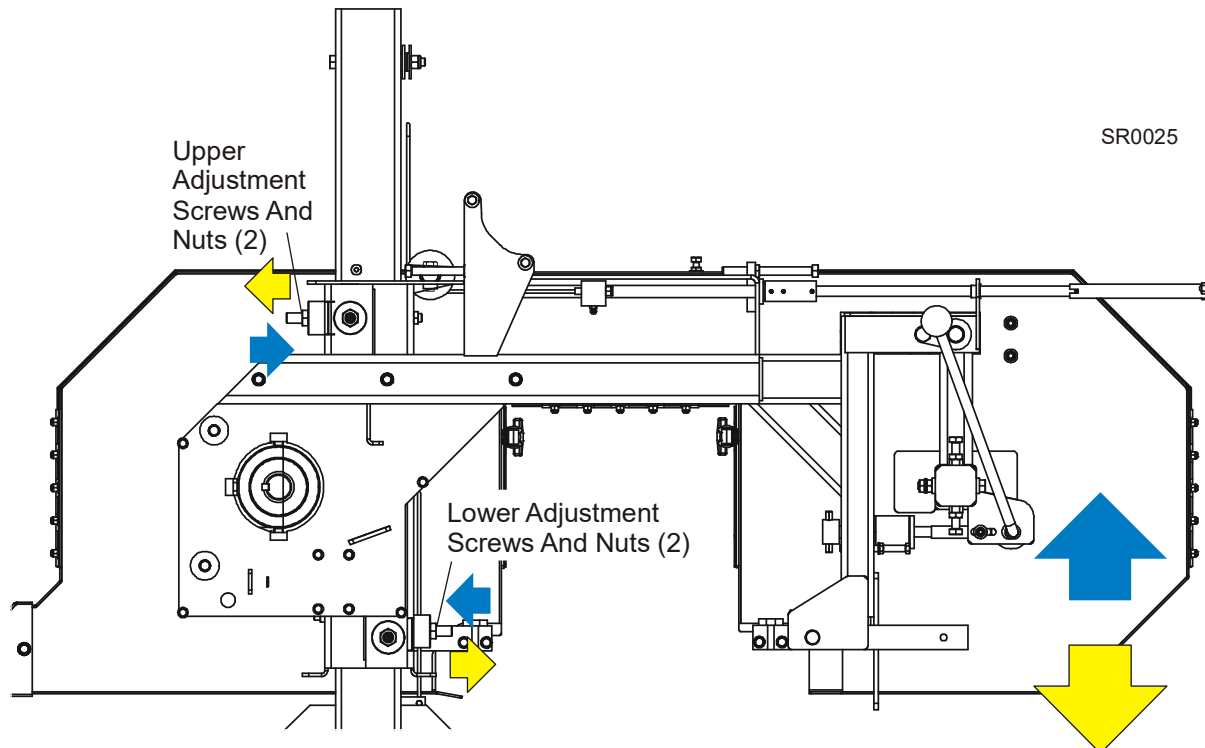

FIG. 5-6

Blade Guide Installation

Each Wood-Mizer resaw has two blade guide assemblies that help the blade maintain a straight cut. The two blade guide assemblies are positioned on the saw head to guide the blade on each side of the material being cut.

One blade guide assembly is mounted in a stationary position on the drive side of the saw head. This assembly is referred to as the "inner" blade guide assembly.

The other blade guide assembly is mounted on the idle side of the saw head. It is referred to as the "outer" assembly and is adjustable for several widths of materials to be processed.

NOTE: Before installing the blade guide assemblies, remove the blade guide adjusting screws and apply a lubricating oil such as 10W30 or Dexron III to each screw. This will prevent the screws and threaded holes from corroding and make screw adjustments easier.

1. Remove the blade from the resaw.
2. **High-Performance Guides Only:** Inspect the guide blocks and repair or replace as necessary. Loosen the top block clamp bolt and mounting bolt. Turn the adjustment bolt counterclockwise to raise the top block all the way up. Remove the bottom guide block from each blade guide assembly and install the provided alignment bar.

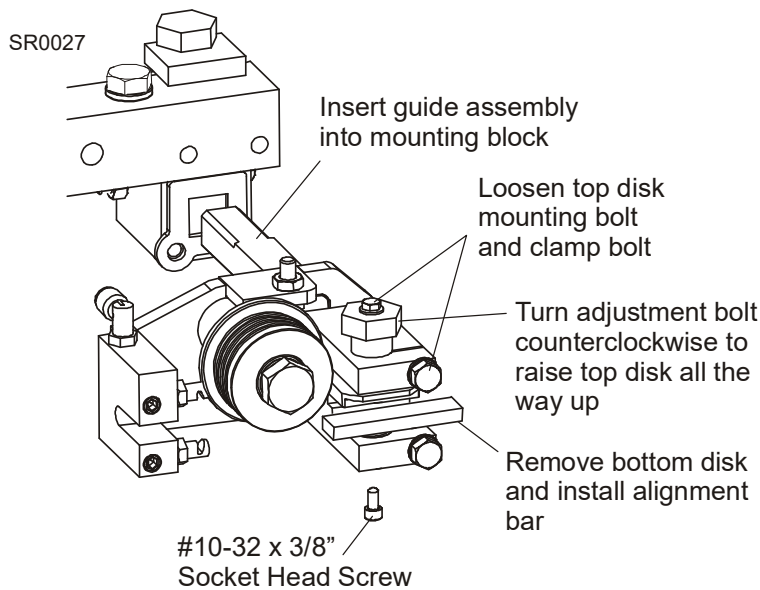

FIG. 5-7

3. Install each blade guide assembly to the mounting blocks and push all the way back. Install, tension and track a new blade. Adjust the outer blade guide assembly so the roller flange is 1/8" from the back of the blade. Adjust the inner blade guide assembly so the roller flange is 1/16" from the blade.

Tighten the two previously-loosened tilt adjustment screws to secure the blade guide assembly. Turn the top adjustment bolt clockwise to raise the blade guide assembly so the roller does not contact the blade.

NOTE: Before adjusting the top bolt, unload pressure on the bolt by turning 1/2 turn in the opposite direction it was last adjusted.

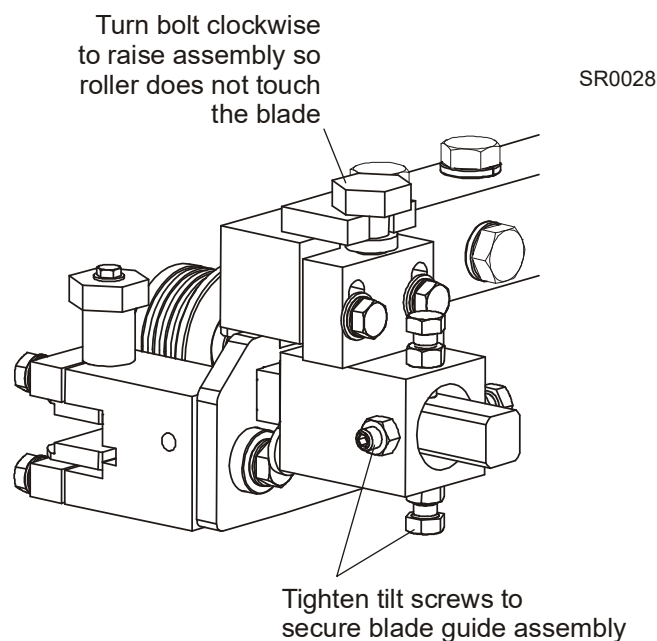

FIG. 5-8

Blade Guide Deflection

Perform the following steps to achieve proper blade deflection with the blade guides.

1. Raise the saw head until the blade is 8" (200 mm) above a feed track. Measure the actual distance with a tape from the top of the feed track to the bottom of the blade.

Turn the top adjustment bolt counterclockwise to lower the assembly until the blade guide roller deflects the blade down until the bottom of the blade measures 7 3/4" (195 mm) from the feed track.

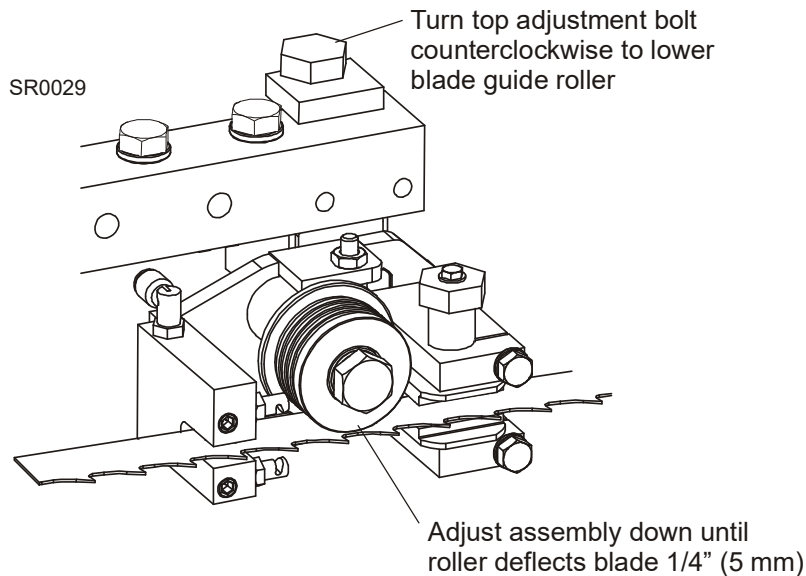

FIG. 5-9

NOTE: Before adjusting the top bolt, unload pressure on the bolt by turning 1/2 turn in the opposite direction it was last adjusted.

2. Repeat for the other blade guide.

Blade Guide Vertical Tilt Alignment

The blade guides should be adjusted properly in the vertical plane. If the blade guides are tilted vertically, the blade will try to travel in the tilted direction.

A Blade Guide Alignment Tool (BGAT) is provided to help you measure the vertical tilt of the blade.

1. Clamp the alignment tool on the blade. Position the tool close to the outer blade guide roller. Be sure the tool does not rest on a tooth or burr, and is lying flat on the blade.

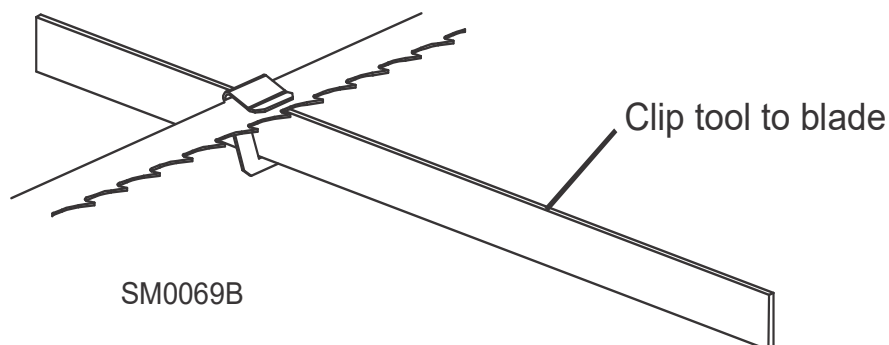

FIG. 5-10

2. Measure the distance from the feed track to the bottom edge of the tool front end.
3. Measure the distance from the feed track to the bottom edge of the tool rear end.
4. If the measurement from the tool to the feed track is not equal, adjust the vertical tilt of the outer blade guide roller.
5. Loosen one set screw at the side of the blade guide assembly.

Loosen the jam nuts on the top and bottom vertical tilt adjustment screws. To tilt the roller up, loosen the bottom screw and tighten top screw. To tilt the roller down, loosen the top screw and tighten the bottom screw. Tighten the jam nuts and recheck the tilt of the blade.

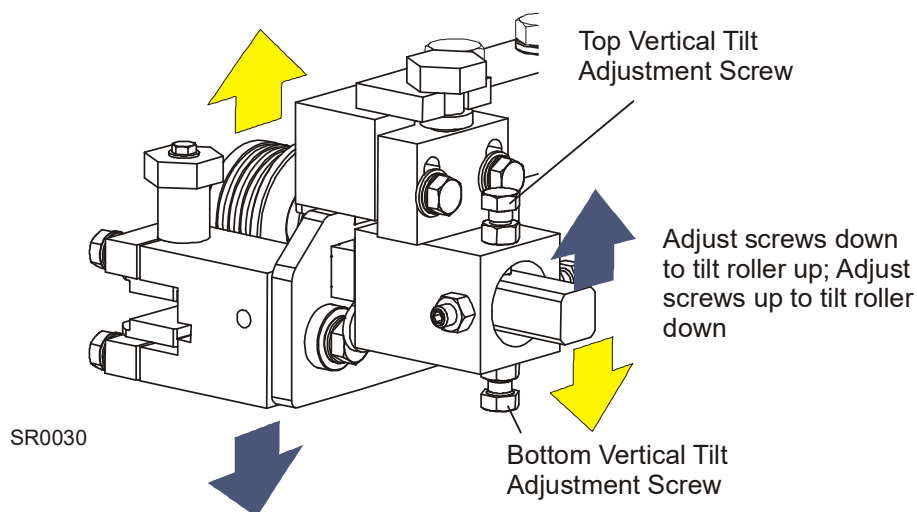

FIG. 5-11

6. Move the blade guide alignment tool close to the inner blade guide roller assembly and repeat the above steps. Adjust the vertical tilt of the inner blade guide if necessary.
7. After adjusting the vertical tilt of the blade guides, recheck the blade deflection and adjust if necessary.

Blade Guide Horizontal Tilt Adjustment

If the blade guides are tilted in the wrong direction horizontally, the back of the blade may contact the flange as the roller is spinning down, causing it to push the blade away from the guide roller.

1. Remove the blade guide alignment tool from the blade.
2. Remove the clip from the blade guide alignment tool. Place the tool against the face of the outer blade guide roller.

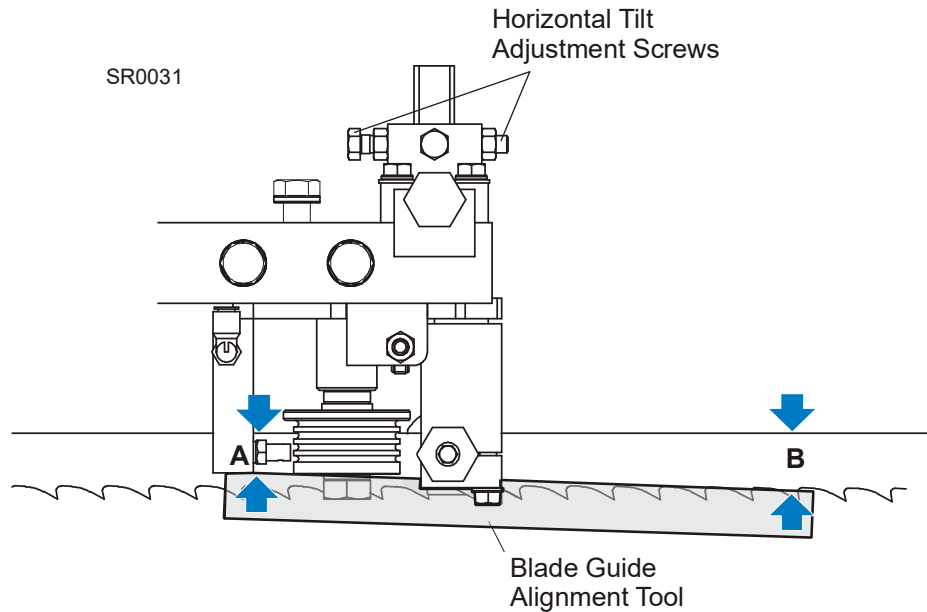
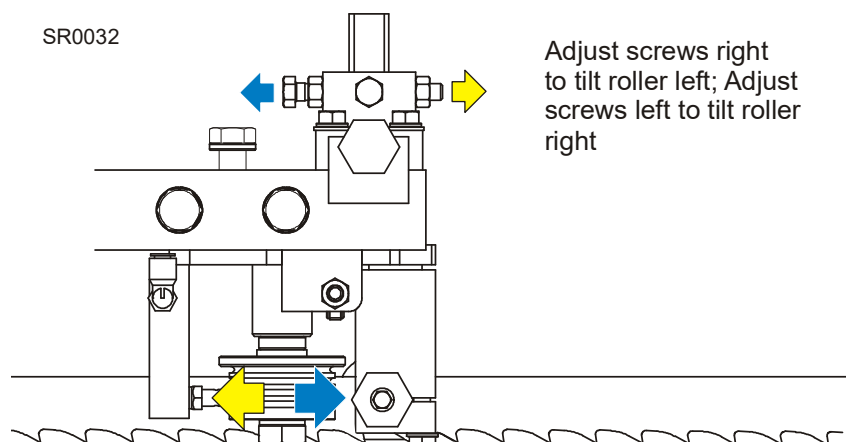

FIG. 5-12

3. Measure between the back edge of the blade and the tool at the end closest to the inner blade guide ("B").
4. Measure between the back edge of the blade and the other end of the tool ("A").

The roller should be tilted slightly to the left ('A' 1/8" [3 mm] less than 'B' ±1/8" [3 mm]).

Loosen the jam nuts on the horizontal tilt adjustment screws. To tilt the roller left, loosen the right screw and tighten left screw. To tilt the roller right, loosen the left screw and tighten the right screw. Tighten the jam nuts and recheck the tilt of the blade.



Adjust screws right to tilt roller left; Adjust screws left to tilt roller right

FIG. 5-13

- Repeat the above steps for the inner blade guide roller assembly.

NOTE: Once the blade guides have been adjusted, any cutting variances are most likely caused by the blade. [See Blade Handbook, Form #600.](#)

Blade Guide Flange Spacing

Each blade guide must be adjusted so the roller flange is the correct distance from the back edge of the blade. If the flange is too close to or too far from the blade, the resaw will not cut accurately.

HINT: When adjusting blade guide spacing, loosen the top set screw and one side set screw only. This will ensure horizontal and vertical tilt adjustments are maintained when the adjustment screws are retightened.

- Measure the distance between the flange on the inner blade guide roller to the back edge of the blade. This distance should measure 1/16" (1.5 mm). Adjust the roller back or forward if necessary.

Loosen the top and one side screw shown. Back the stop bolt out of the way if necessary. Tap the blade guide forward or backward until properly positioned. Retighten the screws and jam nuts. Adjust the stop bolt against the blade guide bracket.

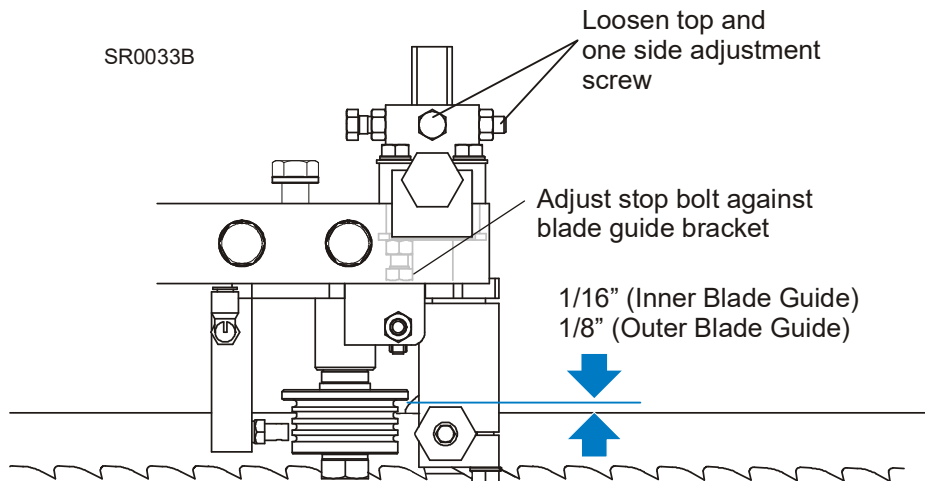

FIG. 5-14

- Measure the distance between the flange on the outer blade guide roller to the back edge of the blade. This distance should measure 1/8" (3.0 mm). Adjust the roller back or forward if necessary.

Blade Deflector Adjustment (Standard Guides Only)

- Install, tension and track the blade.
- Check the blade deflector is centered around and not touching the blade. Loosen the mounting bolt and move the deflector up or down as necessary. Retighten the mounting bolt. Loosen the stop bolt jam nuts and adjust the stop bolt against the deflector. Retighten the jam nuts.

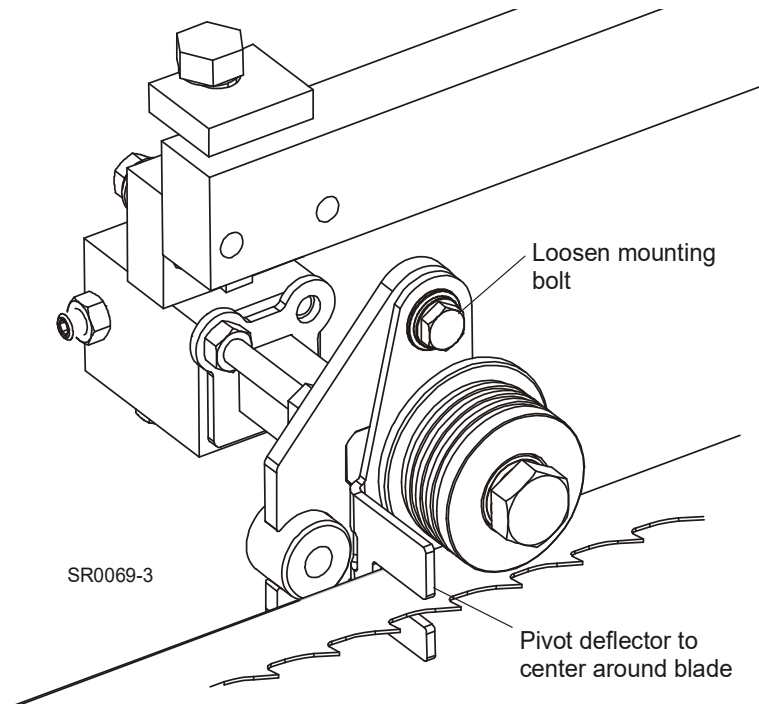

FIG. 5-15

Blade Guide Level (High-Performance Guides Only)

Perform the following adjustments to make sure the blade guide assembly is parallel to the blade.

1. Loosen the alignment bar mounting bolt. Use the provided bottom block adjustment tool to adjust the alignment bar up so the bar is close to, but not touching the bottom of the blade. Retighten the alignment bar mounting bolt
2. Check that the gap from the alignment bar to the blade is the same along entire length of the bar. Shine a flashlight behind the blade guide assembly to help you see the gap between the bar and the blade.

To adjust, loosen the block tilt clamp bolt to pivot the block assembly until the alignment bar is parallel to the blade. Retighten the bolt. Repeat for the second blade guide assembly.

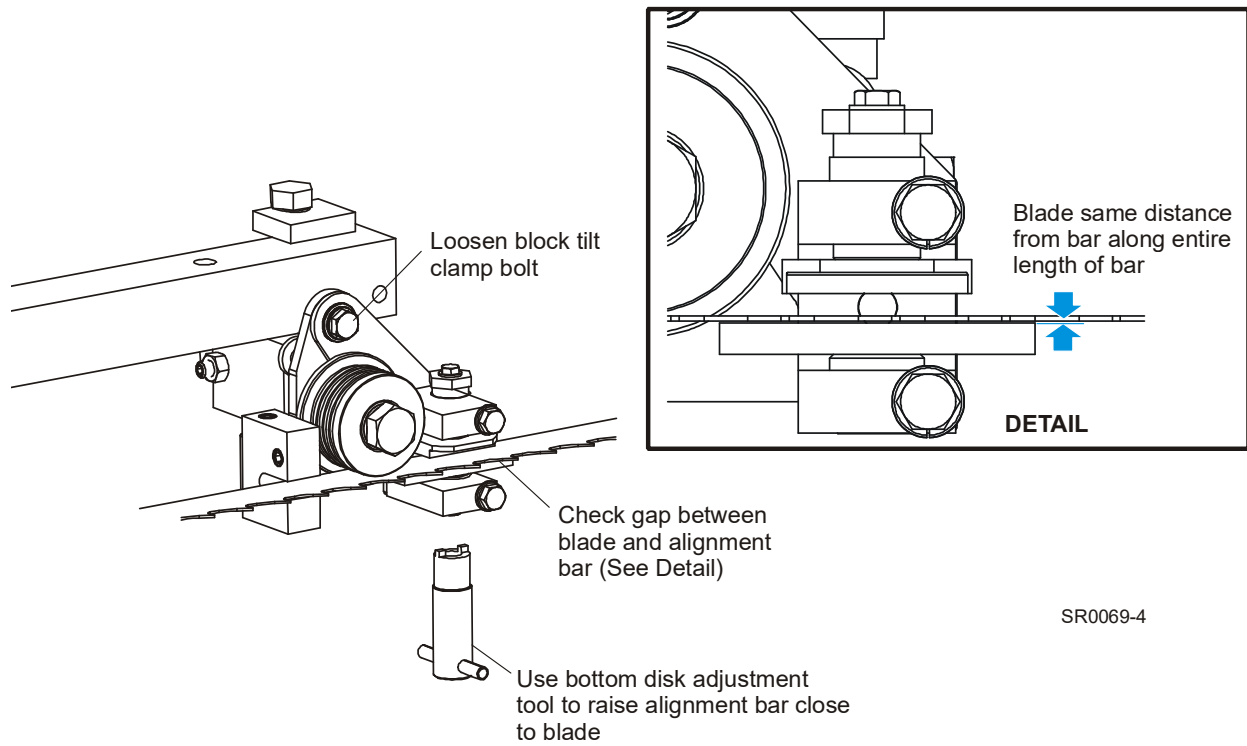

FIG. 5-16

Blade Block Adjustment (High-Performance Guides Only)

1. Replace the alignment bar on each blade guide with the bottom guide block. Use the provided bottom block adjustment tool to lower the bottom block all the way down.

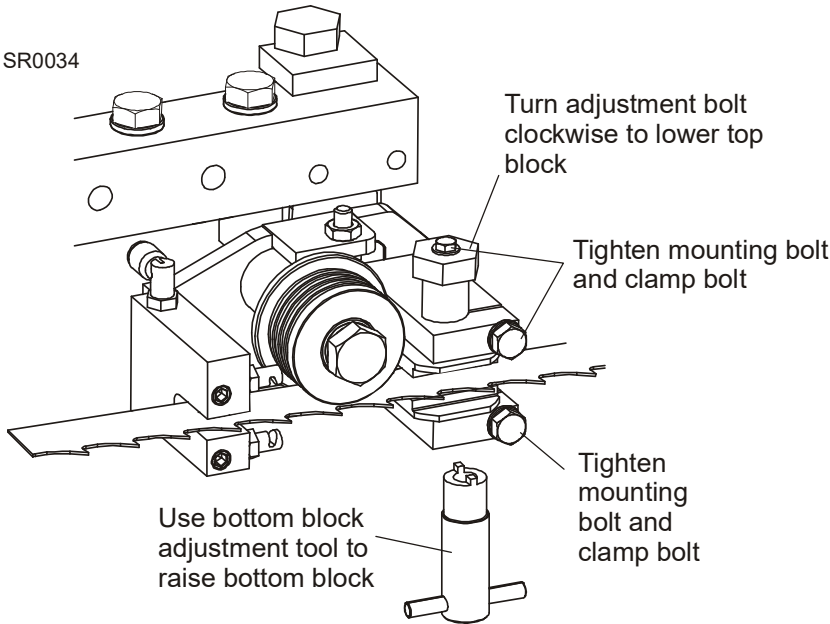

FIG. 5-17

2. Use the bottom block adjustment tool to raise the bottom block to .008" - .010" from the blade. Use the provided shim to set the distance from the block to the blade. Tighten the bottom block mounting bolt and clamp bolt.
3. Turn the top block adjustment bolt clockwise to lower the top block to .008" - .010" from the blade (using the shim as a guide). Tighten the top block mounting bolt and clamp bolt.
4. After tightening the clamp bolt, recheck the distance from the top block to the blade and readjust if necessary.

Pressure Roller Adjustment

Check all pressure rollers for alignment. Each pressure roller should be at the same distance from the corresponding stationary roller to make sure the material is pressed evenly along its length when cutting.

1. Measure the distance between each pair of pressure and stationary rollers.
2. Use the adjustment bolts and jam nuts to move each pressure roller in or out if necessary.

Loosen the jam nut on the adjustment bolt as shown. Turn the adjustment bolt clockwise to move the pressure roller away from the stationary roller. Turn the adjustment bolt counterclockwise to move the pressure roller closer to the stationary roller. Retighten the jam nut.

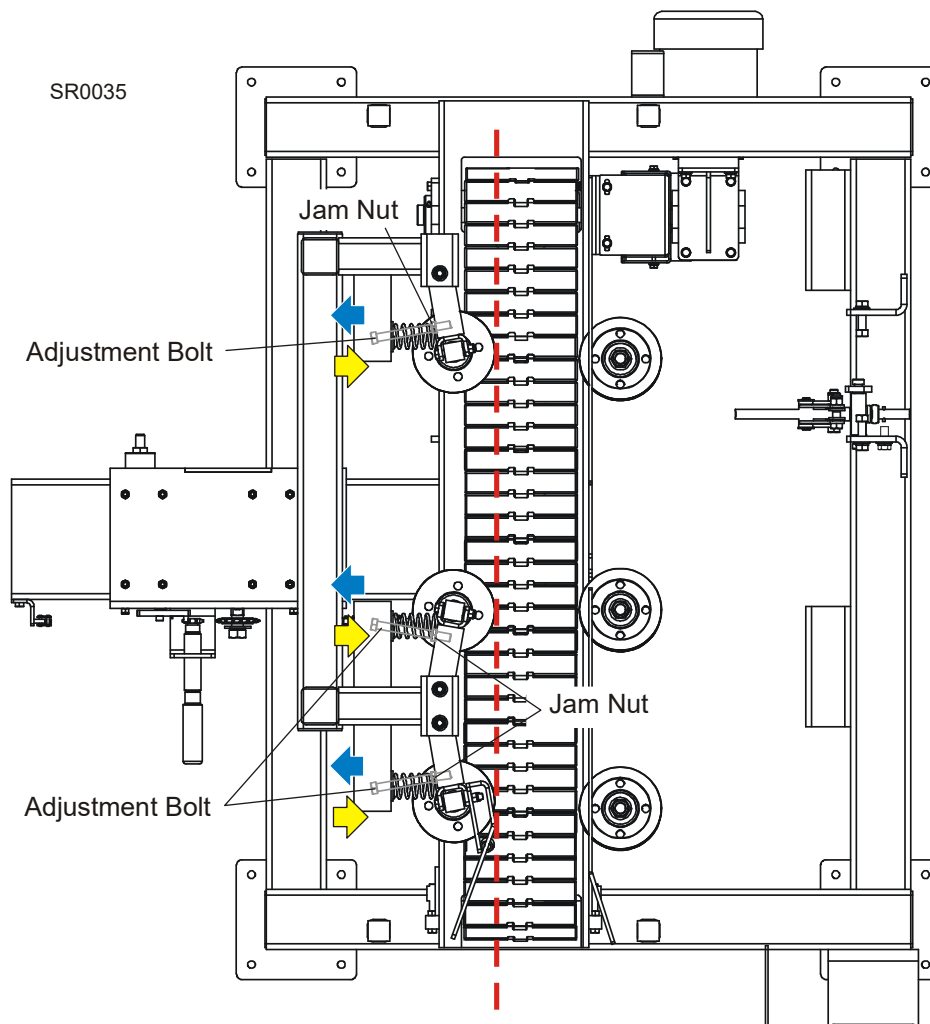

FIG. 5-18

Blade Height Scale Adjustment

After the entire resaw has been aligned and all adjustments made, check that the blade height scale indicates the true distance from the blade to the feed track.

1. Measure from the bottom edge on a down-set tooth of the blade to the top of the feed track.
2. View the blade height scale with eyes level with the indicator. The scale should indicate the actual distance from the blade to the feed track. Adjust the indicator if necessary.

Loosen the indicator mounting bolt. Adjust the scale indicator up or down until the indicator is aligned with the correct mark on the scale (+0 -1/32 [0.8 mm]). Retighten the scale mounting bolts.

For example, if the measurement from the down-set tooth of the blade to the feed track was 8" (200 mm), make sure the indicator reads 8" (200 mm) on the scale.

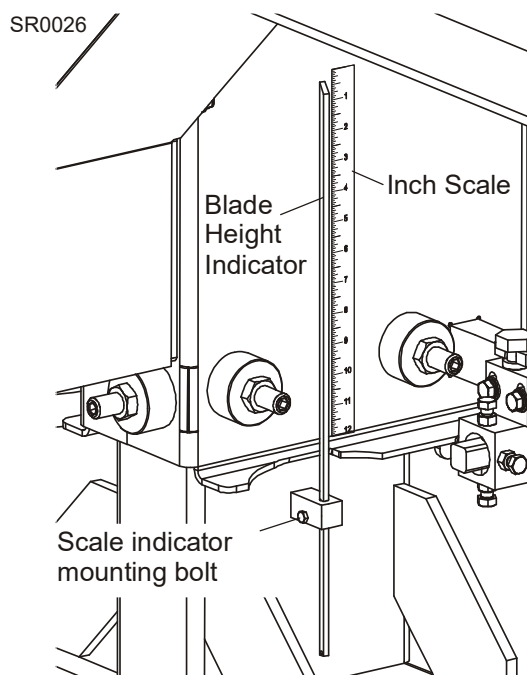

FIG. 5-19

Brake Adjustment

DANGER! Coastdown Required. Always shut down the resaw and allow all moving parts to come to a complete stop before removing any guards or covers. Do NOT operate with any guards or covers removed.

WARNING! Always disconnect and lockout power before performing any service to the resaw. Follow the lockout procedure provided in the safety section ([See Section 2.3](#)). Failure to do so may result in serious injury.

Check the brake cable alignment if necessary.

Remove the drive belt guard to access the brake assembly.

Verify that the drive belt can not be rotated. If the drive belt can be rotated, loosen the brake cable adjustment nut until the belt can not move.

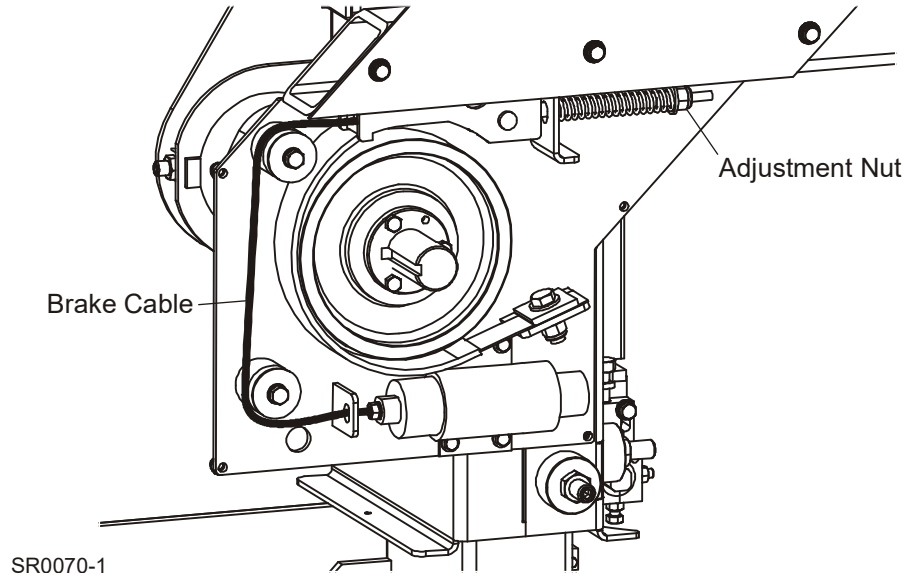

FIG. 5-20

When the brake is engaged properly, the brake cable should be 1/4" away from the brake band.

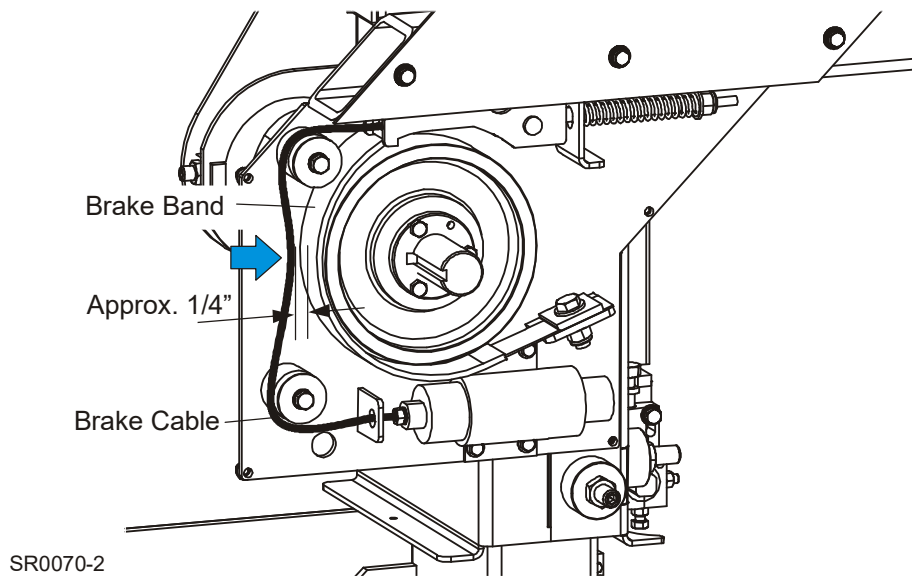

FIG. 5-21

5 Alignment
Alignment Procedure

Start the machine and verify that the brake actuator pulls the cable in to release. If the brake does not release, tighten the brake cable adjustment nut until the brake releases.

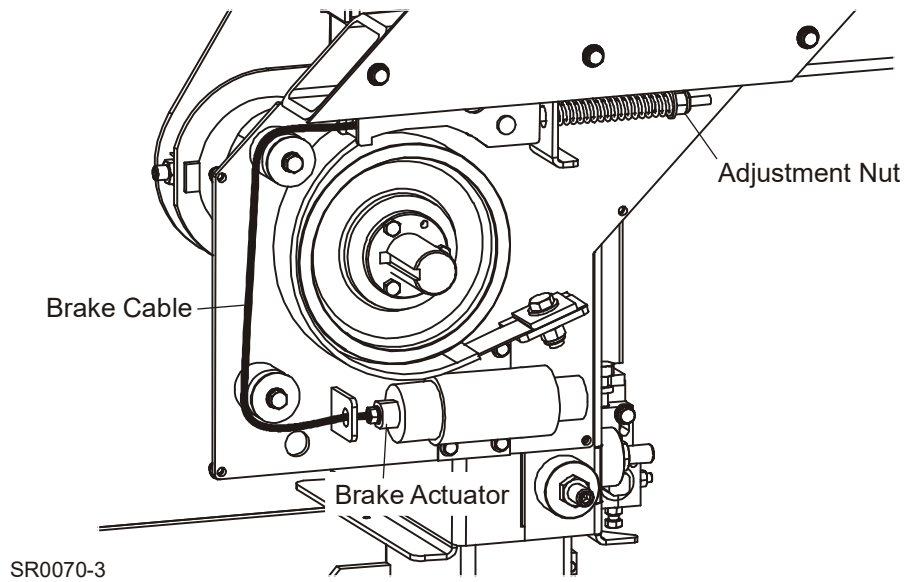

FIG. 5-22

Replace and secure the drive belt guard to the machine.

SECTION 6 ELECTRICAL INFORMATION

6.1 Electrical Symbol Diagrams

HR300EA10-1

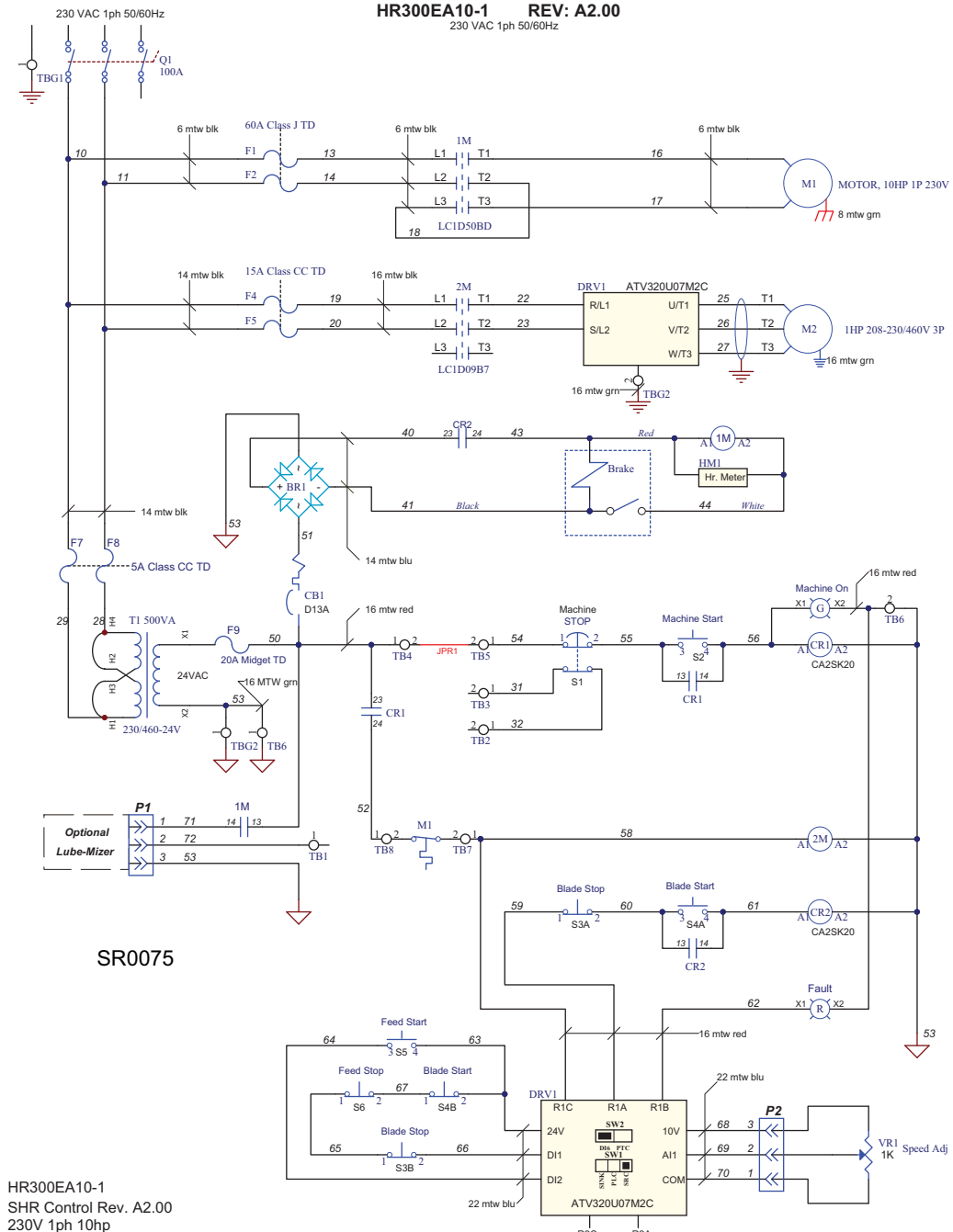

FIG. 6-1 SYMBOL DIAGRAM (HR300EA10-1)

HR300EB20-1

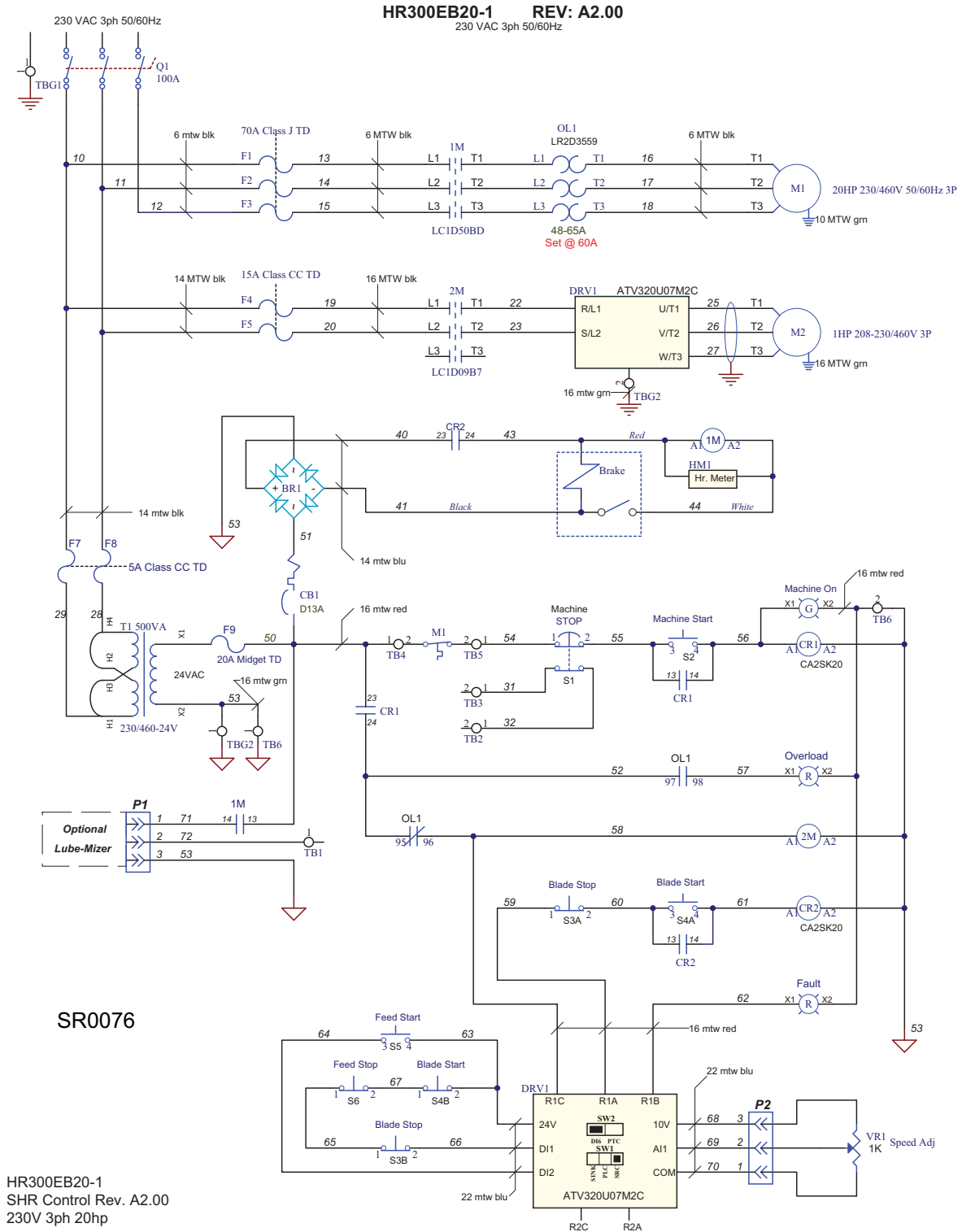
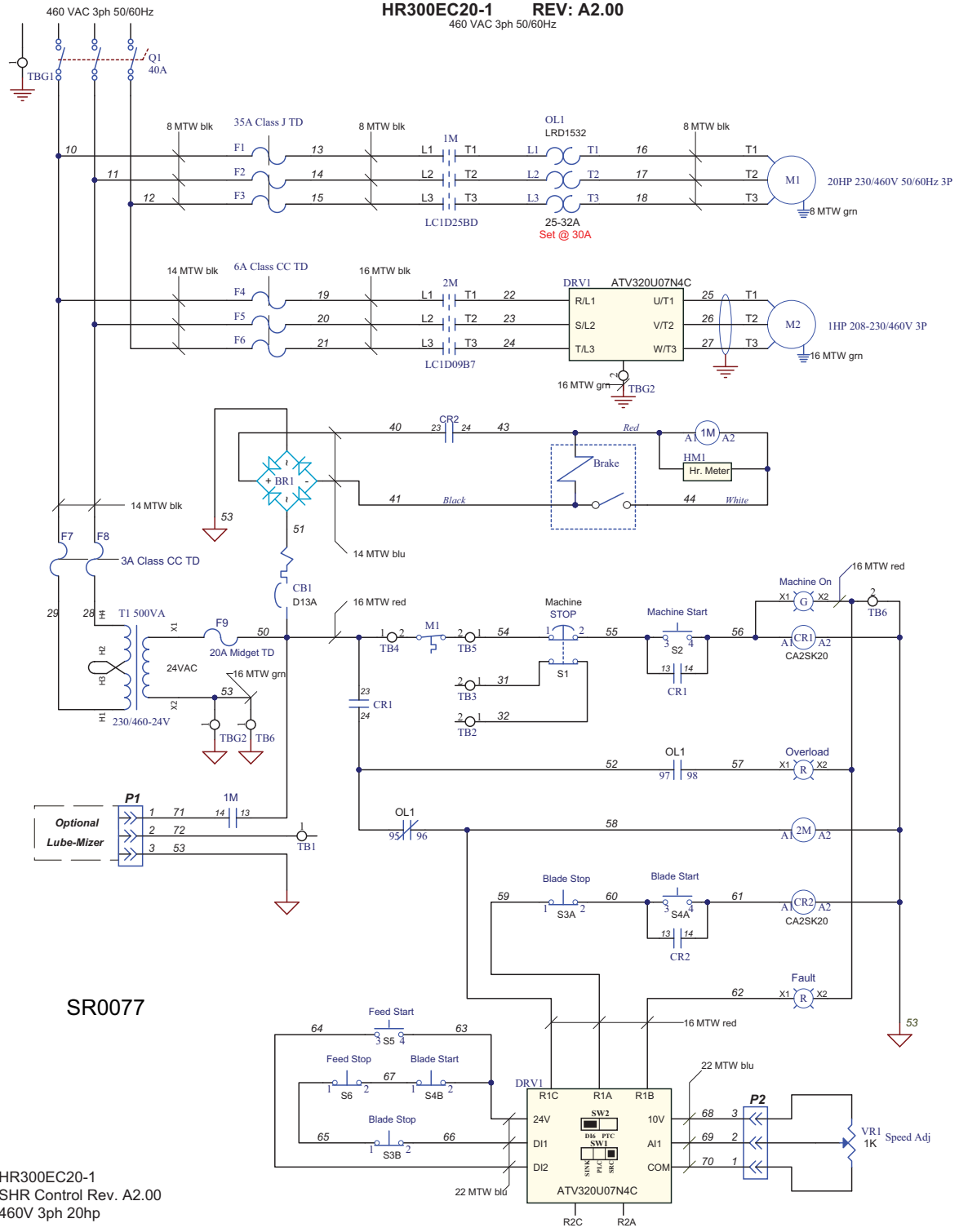

FIG. 6-2 SYMBOL DIAGRAM (HR300EB20-1)

HR300EC20-1



SR0077

HR300EC20-1
SHR Control Rev. A2.00
460V 3ph 20hp

FIG. 6-3 SYMBOL DIAGRAM (HR300EC20-1)

HR300EH20-1

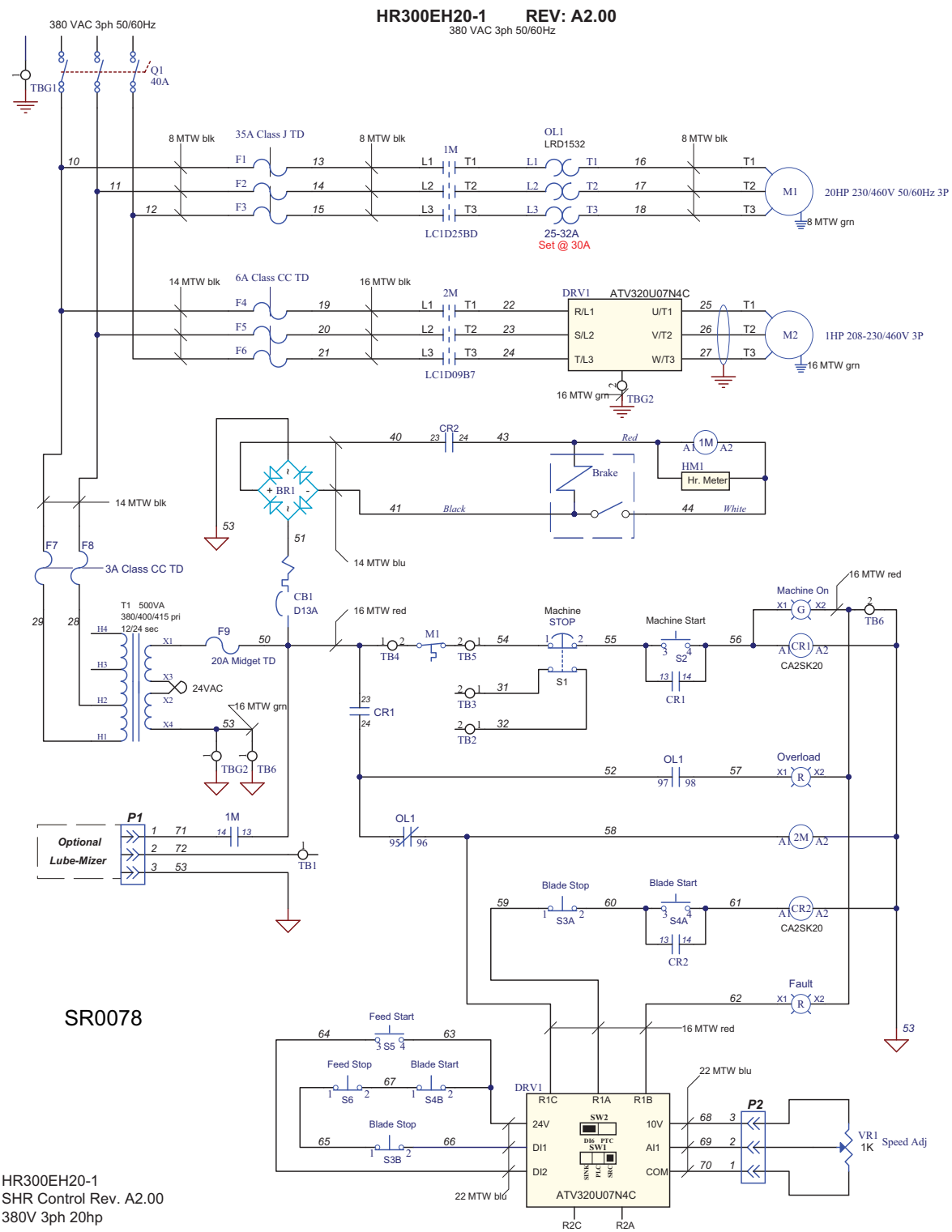

FIG. 6-4 SYMBOL DIAGRAM (HR300EH20-1)

HR300EB25-1

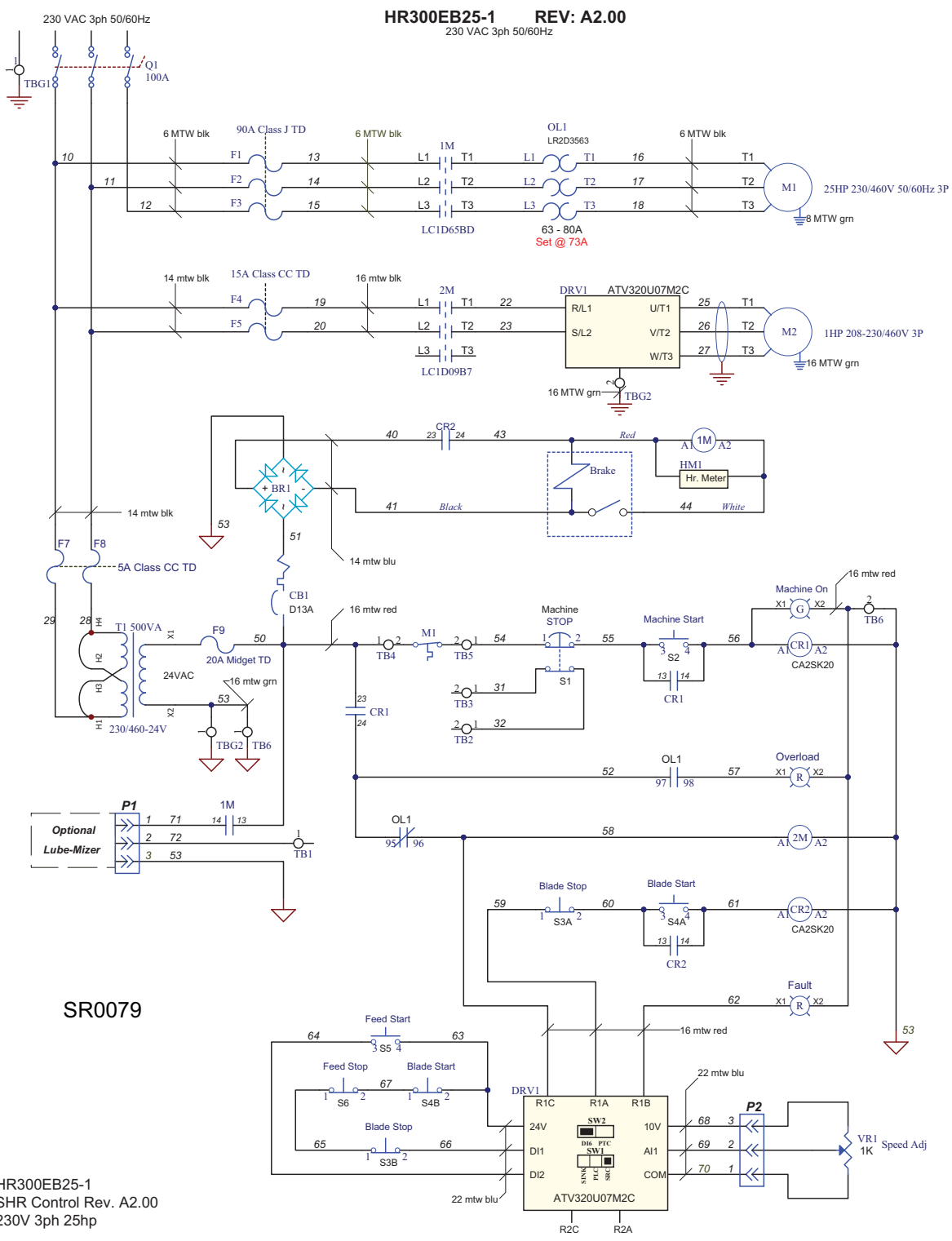

FIG. 6-5 SYMBOL DIAGRAM (HR300EB25-1)

HR300EC25-1

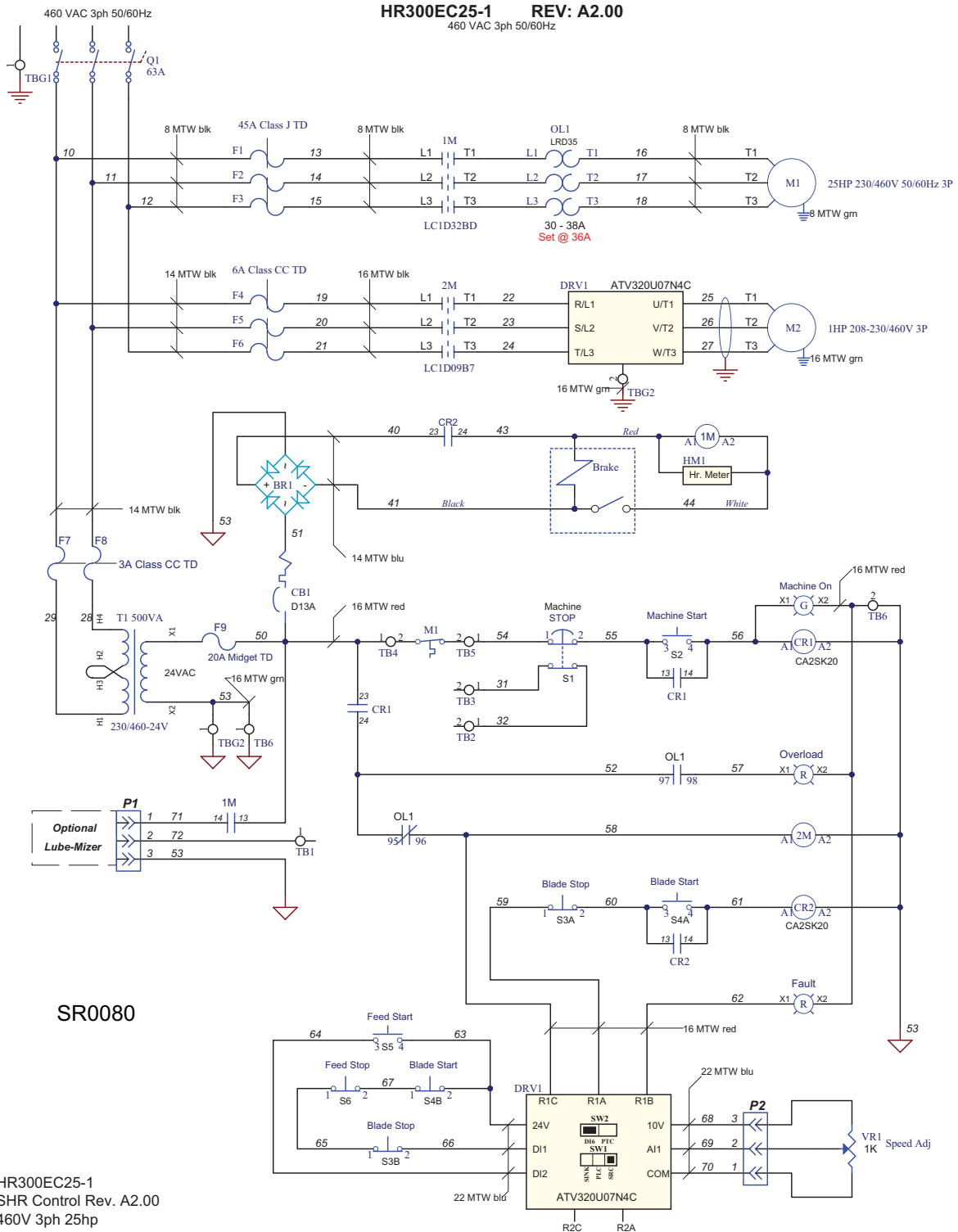
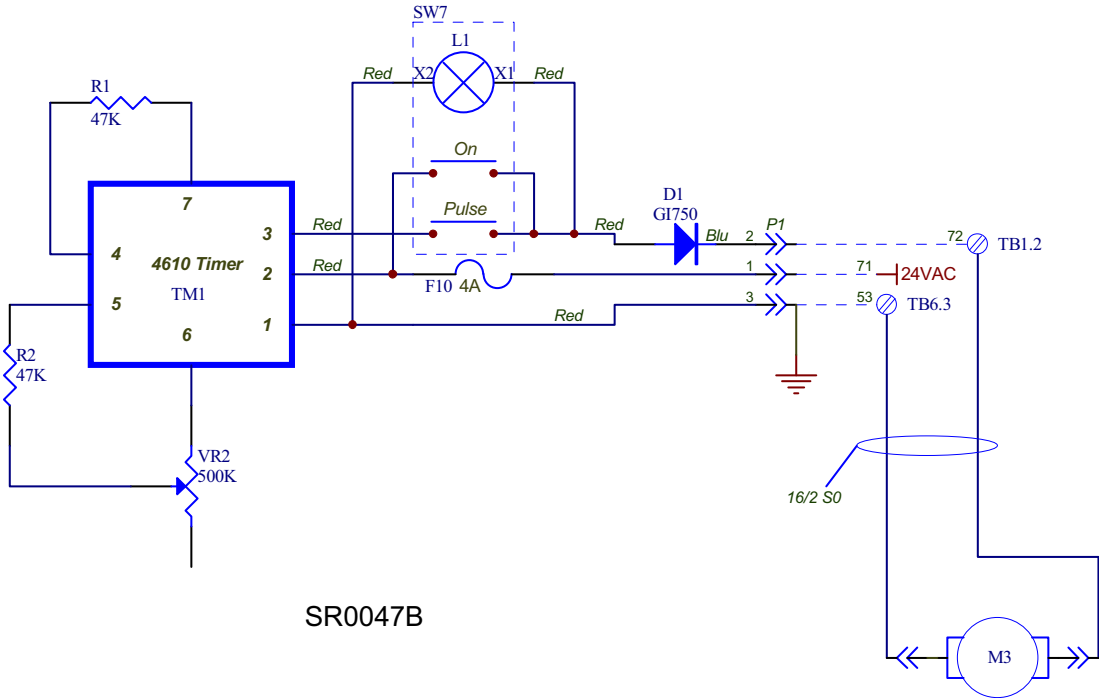

FIG. 6-6 SYMBOL DIAGRAM (HR300EC25-1)

LMS-SHR Lube-Mizer Option

Lube-Mizer Option (SHR)



SR0047B

FIG. 6-7 SYMBOL DIAGRAM (LUBE-MIZER)

6.2 Electrical Component List (HR300EC25-1)

Component	Wood-Mizer Part No.	Description
1M	052465	Contactora, 3 Pole 24VDC 32A
2M	025290	Contactora, 24VAC Coil 3 Pole 9A
BR1	E10456	Rectifier, 200 PIV 35A Bridge
CB1	052463	Breaker, 13A 1 Pole Curve D
CR1, CR2	052464	Relay, 2NO 24VAC Control
D1	052616	Diode Assembly, SHR Lube (LMS Option Only)
F1-F3	052458	Fuse, 45A Class J Delay
F4-F6	052456	Fuse, 6A 600V CCMR Time Delay
F7, F8	052454	Fuse, 3A 600V KLDR Time Delay
F9	052455	Fuse, 20A Midget 250VAC Delay
F10	024150-4	Fuse, 4A ATO Blade Pink (LMS Option Only)
HM1	015401	Hour Meter, 12 Volt DC
M1	038485	Motor, 25HP 1775RPM
M2	047486	Motor, 1HP AC Feed
M3	050029	Pump Assembly, Lube (LMS Option Only)
OL1	052466	Overload Relay, 30-38A Class 10
Q1	050881-1	Disconnect, 63Amp 600V 3P 6mm
	050907-1	Operator, Red/Yellow Pistol Grip 6mm
	050908-1	Shaft, Pistol Grip Disconnect 290mm x 6mm
R1, R2	024591	Resistor Assembly, 47K Yellow Lube Timer (LMS Option Only)
S1	052497	Switch, E-Stop Complete Push-Pull XB5
	050540	Contact, NC ZBE102
S2	052503	Switch, PB Green Flush Illum ZB5
	052502	Switch Body, 22mm Grn LED 1NO 24V XB5
S3/S4	052499	Switch, 2 PBw/Pilot Green Flush Red Extend
	052498	Switch Body, 22mm Red LED 1NO 1NC 24V XB5
	050540	Contact, NC ZBE102 (Qty. 2)
S5/S6	052499	Switch, 2 PBw/Pilot Green Flush Red Extend
	052498	Switch Body, 22mm Red LED 1NO 1NC 24V XB5
SW7	114063	Switch Body, 22mm Clear LED 2NO 24V
	052613	Switch Head, 22mm Illum Green Selector (LMS Option Only)
T1	112655 ¹	Transformer, 500VA 240x480 - 12x24
TM1	052614	Timer Control, Repeat Cycle 24VAC 5 A
TB1-TB5	052461	Terminal Block, 1 Tier Screwless 12GA
TB6	052462	Term Block, 1 Tier/2 Conn Screwless 12GA
TBG1	052525 ²	Terminal Block, 4ga GND
TBG2	052460	Terminal Block, 12GA GND Screwless
U1	052481	AC Drive Assembly, w/Software
VR1	052451	Potentiometer Assembly, 1K SHR Feed Control
VR2	024590	Potentiometer Assembly, Lube-Mizer Control (LMS Option Only)

¹ Was 052453, ECN: 39084

² 052525 replaced 052459 after 8/22/2022 per ECN 38687

6.3 Electrical Component List (HR300EB25-1)

Component	Wood-Mizer Part No.	Description
1M	053604	Contactors, 65A 3P 24VDC D-A Series
2M	025290	Contactors, 24VAC Coil 3 Pole 9A
BR1	E10456	Rectifier, 200 PIV 35A Bridge
CB1	052463	Breaker, 13A 1 Pole Curve D
CR1, CR2	052464	Relay, 2NO 24VAC Control
D1	052616	Diode Assembly, SHR Lube (LMS Option Only)
F1-F3	052515	Fuse, 90A Class J Delay
F4, F5	052513	Fuse, 15A 600V CCMR Time Delay
F6	052456	Fuse, 6A 600V CCMR Time Delay
F7, F8	052511	Fuse, 5A 600V KLDR Time Delay (SHR10/SHR20-L/SHR25-L Only)
F9	052455	Fuse, 20A Midget 250VAC Delay
F10	024150-4	Fuse, 4A ATO Blade Pink (LMS Option Only)
HM1	015401	Hour Meter, 12 Volt DC
M1	038485	Motor, 25HP 1775RPM
M2	047486	Motor, 1HP AC Feed
M3	050029	Pump Assembly, Lube (LMS Option Only)
OL1	069636	Overload Relay, 48-65A
Q1	050906-1	Disconnect, 100Amp 3P Non-Fused 6mm
	050907-1	Operator, Red/Yellow Pistol Grip 6mm
	050908-1	Shaft, Pistol Grip Disconnect 290mm x 6mm
R1, R2	024591	Resistor Assembly, 47K Yellow Lube Timer (LMS Option Only)
S1	052497	Switch, E-Stop Complete Push-Pull XB5
	050540	Contact, NC ZBE102
S2	052503	Switch, PB Green Flush Illum ZB5
	052502	Switch Body, 22mm Grn LED 1NO 24V XB5
S3/S4	052499	Switch, 2 PBw/Pilot Green Flush Red Extend
	052498	Switch Body, 22mm Red LED 1NO 1NC 24V XB5
	050540	Contact, NC ZBE102 (Qty. 2)
S5/S6	052499	Switch, 2 PBw/Pilot Green Flush Red Extend
	052498	Switch Body, 22mm Red LED 1NO 1NC 24V XB5
SW7	114063	Switch Body, 22mm Clear LED 2NO 24V
	052613	Switch Head, 22mm Illum Green Selector (LMS Option Only)
T1	112655 ¹	Transformer, 500VA 240x480 - 12x24
TM1	052614	Timer Control, Repeat Cycle 24VAC 5 A (LMS Option Only)
TB1-TB5	052461	Terminal Block, 1 Tier Screwless 12GA
TB6	052462	Term Block, 1 Tier/2 Conn Screwless 12GA
TBG1	052525	Terminal Block, 4GA GND Screwless
TBG2	052460	Terminal Block, 12GA GND Screwless
U1	052518-1	AC Drive Assembly, w/Software (ATV320)
VR1	052451	Potentiometer Assembly, 1K SHR Feed Control
VR2	024590	Potentiometer Assembly, Lube-Mizer Control (LMS Option Only)

¹ Was 052453, ECN: 39084

6.4 Electrical Component List (HR300EC20-1)

Component	Wood-Mizer Part No.	Description
1M	051322	Contactors, 3 Pole 24VDC
2M	025290	Contactors, 24VAC Coil 3 Pole 9A
BR1	E10456	Rectifier, 200 PIV 35A Bridge
CB1	052463	Breaker, 13A 1 Pole Curve D
CR1, CR2	052464	Relay, 2NO 24VAC Control
D1	052616	Diode Assembly, SHR Lube (LMS Option Only)
F1-F3	052506	Fuse, 35A Class J Delay
F4-F6	052456	Fuse, 6A 600V CCMR Time Delay
F7, F8	052454	Fuse, 3A 600V KLDR Time Delay
F9	052455	Fuse, 20A Midget 250VAC Delay
F10	024150-4	Fuse, 4A ATO Blade Pink (LMS Option Only)
HM1	015401 ¹	Hour Meter, 12 Volt DC
M1	038486	Motor, 20HP 1755RPM
M2	047486	Motor, 1HP AC Feed
M3	050029	Pump Assembly, Lube (LMS Option Only)
OL1	052505	Overload Relay, 25-32A Class 10
Q1	050903-1	Disconnect, 40A 3P Non-Fused 6mm
	050907-1	Operator, Red/Yellow Pistol Grip 6mm
	050908-1	Shaft, Pistol Grip Disconnect 290mm x 6mm
R1, R2	024591	Resistor Assembly, 47K Yellow Lube Timer (LMS Option Only)
S1	052497	Switch, E-Stop Complete Push-Pull XB5
	050540	Contact, NC ZBE102
S2	052503	Switch, PB Green Flush Illum ZB5
	052502	Switch Body, 22mm Grn LED 1NO 24V XB5
S3/S4	052499	Switch, 2 PBw/Pilot Green Flush Red Extend
	052498	Switch Body, 22mm Red LED 1NO 1NC 24V XB5
	050540	Contact, NC ZBE102 (Qty. 2)
S5/S6	052499	Switch, 2 PBw/Pilot Green Flush Red Extend
	052498	Switch Body, 22mm Red LED 1NO 1NC 24V XB5
SW7	114063	Switch Body, 22mm Clear LED 2NO 24V
	052613	Switch Head, 22mm Illum Green Selector (LMS Option Only)
T1	052453	Transformer, 208-480V/24V 500VA
TM1	052614	Timer Control, Repeat Cycle 24VAC 5 A (LMS Option Only)
TB1-TB5	052461	Terminal Block, 1 Tier Screwless 12GA
TB6	052462	Term Block, 1 Tier/2 Conn Screwless 12GA
TBG1	052525 ²	Terminal Block, 4ga GND
TBG2	052460	Terminal Block, 12GA GND Screwless
U1	052481	AC Drive Assembly, w/Software
VR1	052451	Potentiometer Assembly, 1K SHR Feed Control
VR2	024590	Potentiometer Assembly, Lube-Mizer Control (LMS Option Only)

¹ Was ENM Corp. #T14BH517BC9 (2/09).

² 052525 replaced 052459 after 8/22/2022 per ECN 38687

6.5 Electrical Component List (HR300EB20-1)

Component	Wood-Mizer Part No.	Description
1M	053601	Contactors, 50A 3P 24VDC D-A Series
2M	025290	Contactors, 24VAC Coil 3 Pole 9A
BR1	E10456	Rectifier, 200 PIV 35A Bridge
CB1	052463	Breaker, 13A 1 Pole Curve D
CR1, CR2	052464	Relay, 2NO 24VAC Control
D1	052616	Diode Assembly, SHR Lube (LMS Option Only)
F1, F2	052521	Fuse, 70A Class J Delay
F3	052521	Fuse, 70A Class J Delay
F4, F5	052513	Fuse, 15A 600V CCMR Time Delay
F6	052456	Fuse, 6A 600V CCMR Time Delay
F7, F8	052511	Fuse, 5A 600V KLDR Time Delay
F9	052455	Fuse, 20A Midget 250VAC Delay
F10	024150-4	Fuse, 4A ATO Blade Pink (LMS Option Only)
HM1	015401	Hour Meter, 12 Volt DC
M1	038486	Motor, 20HP 1755RPM
M2	047486	Motor, 1HP AC Feed
M3	050029	Pump Assembly, Lube (LMS Option Only)
OL1	069636	Overload Relay, 48-65A Everlink Thermal
Q1	050906-1	Disconnect, 100Amp 3P Non-Fused 6mm
	050907-1	Operator, Red/Yellow Pistol Grip 6mm
	050908-1	Shaft, Pistol Grip Disconnect 290mm x 6mm
R1, R2	024591	Resistor Assembly, 47K Yellow Lube Timer (LMS Option Only)
S1	052497	Switch, E-Stop Complete Push-Pull XB5
	050540	Contact, NC ZBE102
S2	052503	Switch, PB Green Flush Illum ZB5
	052502	Switch Body, 22mm Grn LED 1NO 24V XB5
S3/S4	052499	Switch, 2 PBw/Pilot Green Flush Red Extend
	052498	Switch Body, 22mm Red LED 1NO 1NC 24V XB5
	050540	Contact, NC ZBE102 (Qty. 2)
S5/S6	052499	Switch, 2 PBw/Pilot Green Flush Red Extend
	052498	Switch Body, 22mm Red LED 1NO 1NC 24V XB5
SW7	114063	Switch Body, 22mm Clear LED 2NO 24V
	052613	Switch Head, 22mm Illum Green Selector (LMS Option Only)
T1	112655 ¹	Transformer, 500VA 240x480 - 12x24
TM1	052614	Timer Control, Repeat Cycle 24VAC 5 A (LMS Option Only)
TB1-TB5	052461	Terminal Block, 1 Tier Screwless 12GA
TB6	052462	Term Block, 1 Tier/2 Conn Screwless 12GA
TBG1	052525	Terminal Block, 4GA GND Screwless
TBG2	052460	Terminal Block, 12GA GND Screwless
U1	052518-1	AC Drive Assembly, w/Software (SHR10/SHR20-L/SHR25-L Only) (ATV320)
VR1	052451	Potentiometer Assembly, 1K SHR Feed Control
VR2	024590	Potentiometer Assembly, Lube-Mizer Control (LMS Option Only)

¹ Was 052453, ECN: 39084

6.6 Electrical Component List (HR300EH20-1)

Component	Wood-Mizer Part No.	Description
1M	051322	Contactora, 3 Pole 24VDC
2M	025290	Contactora, 24VAC Coil 3 Pole 9A
BR1	E10456	Rectifier, 200 PIV 35A Bridge
CB1	052463	Breaker, 13A 1 Pole Curve D
CR1, CR2	052464	Relay, 2NO 24VAC Control
D1	052616	Diode Assembly, SHR Lube (LMS Option Only)
F1-F3	052506	Fuse, 35A Class J Delay
F4-F6	052456	Fuse, 6A 600V CCMR Time Delay
F7, F8	052454	Fuse, 3A 600V KLDLDR Time Delay
F9	052455	Fuse, 20A Midget 250VAC Delay
F10	024150-4	Fuse, 4A ATO Blade Pink (LMS Option Only)
HM1	015401	Hour Meter, 12 Volt DC
M1	038486	Motor, 20HP 1755RPM
M2	047486	Motor, 1HP AC Feed
M3	050029	Pump Assembly, Lube (LMS Option Only)
OL1	052505	Overload Relay, 25-32A Class 10
Q1	050903-1	Disconnect, 40A 3P Non-Fused 6mm
	050907-1	Operator, Red/Yellow Pistol Grip 6mm
	050908-1	Shaft, Pistol Grip Disconnect 290mm x 6mm
R1, R2	024591	Resistor Assembly, 47K Yellow Lube Timer (LMS Option Only)
S1	052497	Switch, E-Stop Complete Push-Pull XB5
	050540	Contact, NC ZBE102
S2	052503	Switch, PB Green Flush Illum ZB5
	052502	Switch Body, 22mm Grn LED 1NO 24V XB5
S3/S4	052499	Switch, 2 PBw/Pilot Green Flush Red Extend
	052498	Switch Body, 22mm Red LED 1NO 1NC 24V XB5
	050540	Contact, NC ZBE102 (Qty. 2)
S5/S6	052499	Switch, 2 PBw/Pilot Green Flush Red Extend
	052498	Switch Body, 22mm Red LED 1NO 1NC 24V XB5
SW7	114063	Switch Body, 22mm Clear LED 2NO 24V
	052613	Switch Head, 22mm Illum Green Selector (LMS Option Only)
T1	052773	Transformer, 380/400/415-12/24V 500VA (SHR20-380 Only)
TM1	052614	Timer Control, Repeat Cycle 24VAC 5 A (LMS Option Only)
TB1-TB5	052461	Terminal Block, 1 Tier Screwless 12GA
TB6	052462	Term Block, 1 Tier/2 Conn Screwless 12GA
TBG1	052525 ¹	Terminal Block, 4ga GND
TBG2	052460	Terminal Block, 12GA GND Screwless
U1	052481	AC Drive Assembly, w/Software
VR1	052451	Potentiometer Assembly, 1K SHR Feed Control
VR2	024590	Potentiometer Assembly, Lube-Mizer Control (LMS Option Only)

¹ 052525 replaced 052459 after 8/22/2022 per ECN 38687

6.7 Electrical Component List (HR300EA10-1)

Component	Wood-Mizer Part No.	Description
1M	053601	Contact, 50A 3P 24VDC D-A Series
2M	025290	Contact, 24VAC Coil 3 Pole 9A
BR1	E10456	Rectifier, 200 PIV 35A Bridge
CB1	052463	Breaker, 13A 1 Pole Curve D
CR1, CR2	052464	Relay, 2NO 24VAC Control
D1	052616	Diode Assembly, SHR Lube (LMS Option Only)
F1, F2	052733	Fuse, 60A Class J Delay
F4, F5	052513	Fuse, 15A 600V CCMR Time Delay
F6	052456	Fuse, 6A 600V CCMR Time Delay
F7, F8	052511	Fuse, 5A 600V KLDR Time Delay
F9	052455	Fuse, 20A Midget 250VAC Delay
F10	024150-4	Fuse, 4A ATO Blade Pink (LMS Option Only)
HM1	015401	Hour Meter, 12 Volt DC
M1	038487	Motor, 10HP 1725RPM Single Phase
M2	047486	Motor, 1HP AC Feed
M3	050029	Pump Assembly, Lube (LMS Option Only)
Q1	050906-1	Disconnect, 100Amp 3P Non-Fused 6mm
	050907-1	Operator, Red/Yellow Pistol Grip 6mm
	050908-1	Shaft, Pistol Grip Disconnect 290mm x 6mm
R1, R2	024591	Resistor Assembly, 47K Yellow Lube Timer (LMS Option Only)
S1	052497	Switch, E-Stop Complete Push-Pull XB5
	050540	Contact, NC ZBE102
S2	052503	Switch, PB Green Flush Illum ZB5
	052502	Switch Body, 22mm Grn LED 1NO 24V XB5
S3/S4	052499	Switch, 2 PBw/Pilot Green Flush Red Extend
	052498	Switch Body, 22mm Red LED 1NO 1NC 24V XB5
	050540	Contact, NC ZBE102 (Qty. 2)
S5/S6	052499	Switch, 2 PBw/Pilot Green Flush Red Extend
	052498	Switch Body, 22mm Red LED 1NO 1NC 24V XB5
SW7	114063	Switch Body, 22mm Clear LED 2NO 24V
	052613	Switch Head, 22mm Illum Green Selector (LMS Option Only)
T1	112655 ¹	Transformer, 500VA 240x480 - 12x24
TM1	052614	Timer Control, Repeat Cycle 24VAC 5 A (LMS Option Only)
TB1-TB5	052461	Terminal Block, 1 Tier Screwless 12GA
TB6	052462	Term Block, 1 Tier/2 Conn Screwless 12GA
TBG1	052525	Terminal Block, 4GA GND Screwless
TBG2	052460	Terminal Block, 12GA GND Screwless
U1	052518-1	AC Drive Assembly, w/Software (ATV320)
VR1	052451	Potentiometer Assembly, 1K SHR Feed Control
VR2	024590	Potentiometer Assembly, Lube-Mizer Control (LMS Option Only)

¹ Was 052453, ECN: 39084

6.8 Component Layout Diagrams

Control Box (HR300EC20-1/HR300EH20-1/HR300EC25-1)

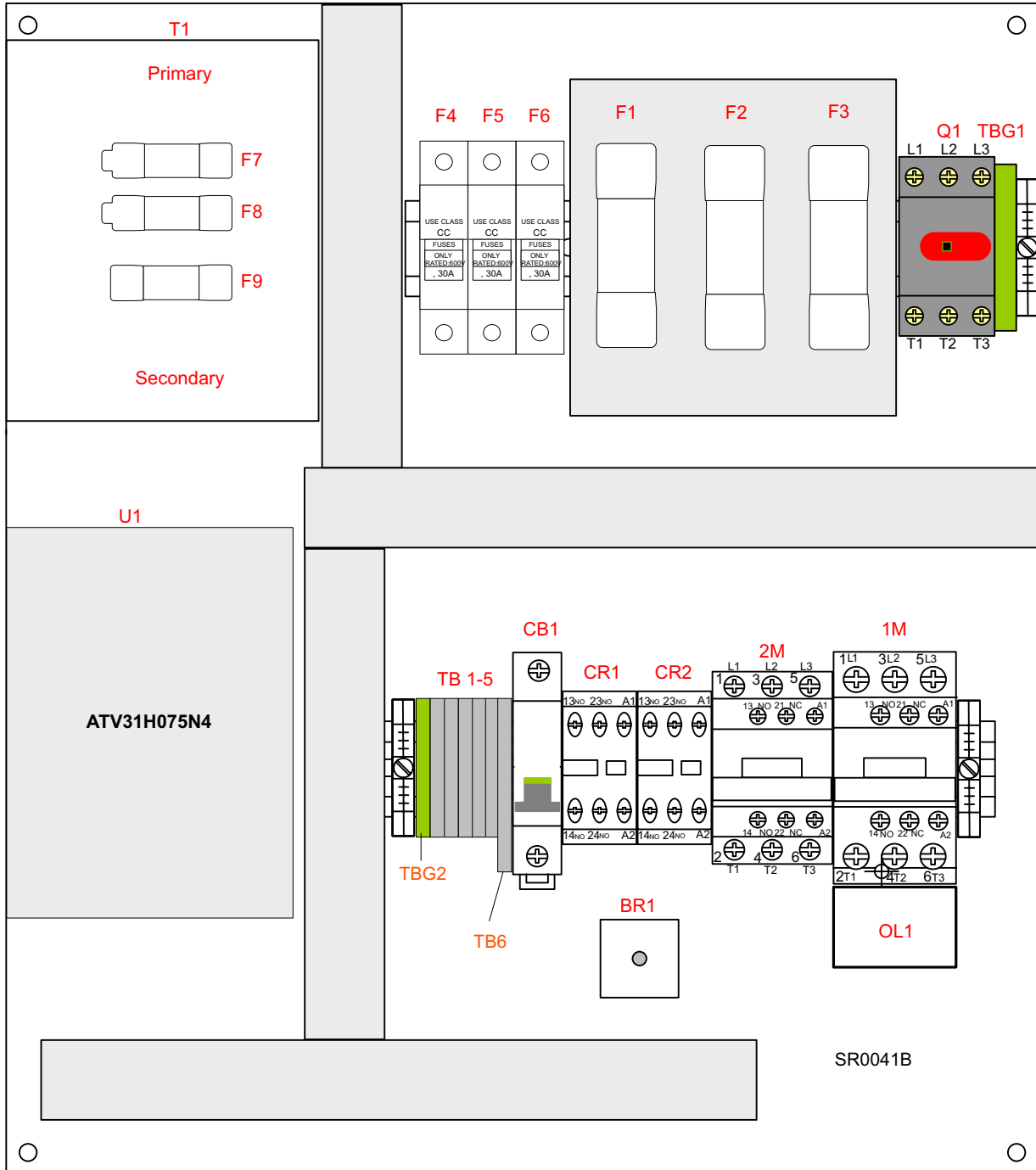

FIG. 6-7

Control Box (HR300EB20-1/HR300EB25-1)

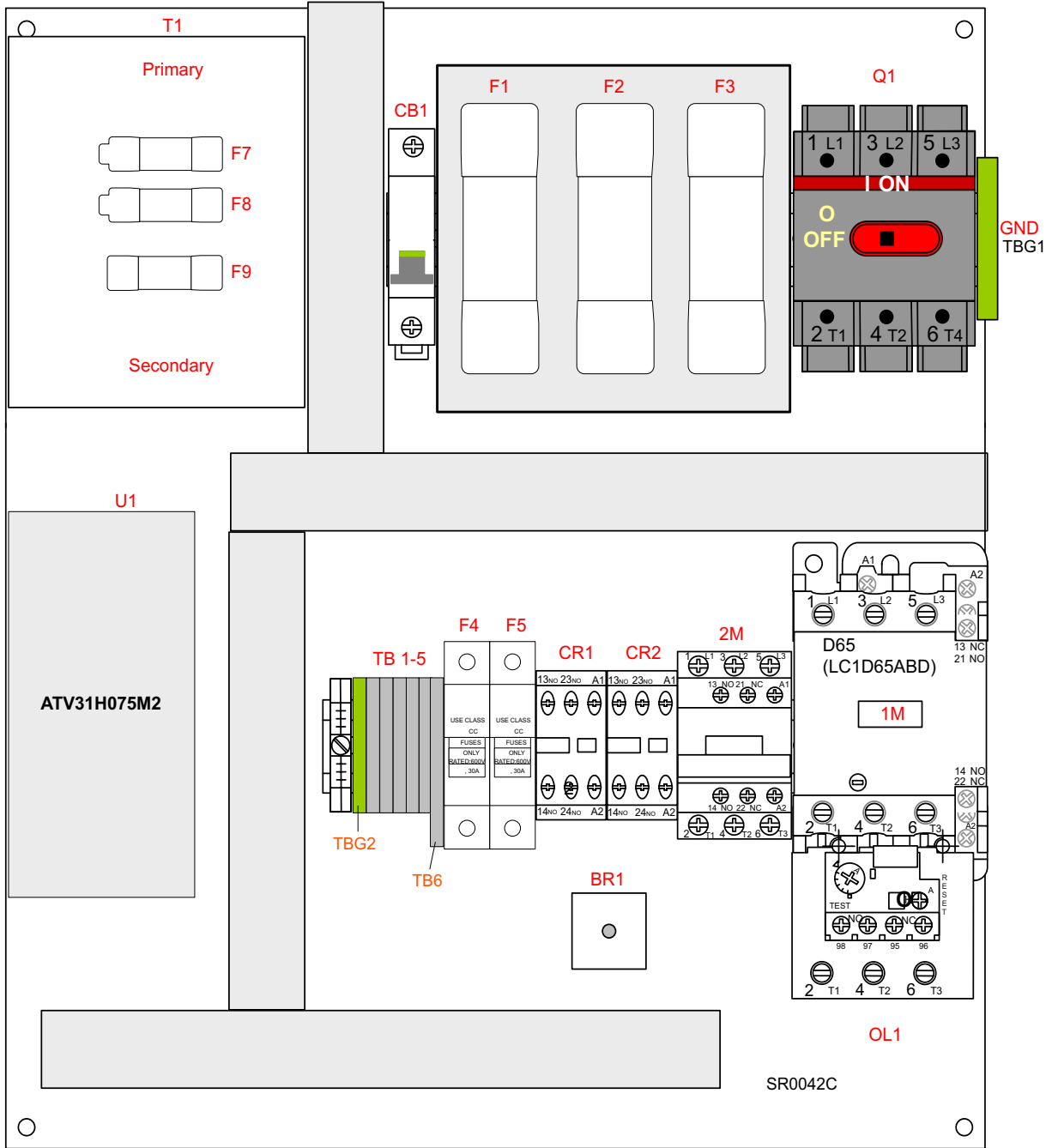

FIG. 6-7

Control Box (HR300EA10-1)

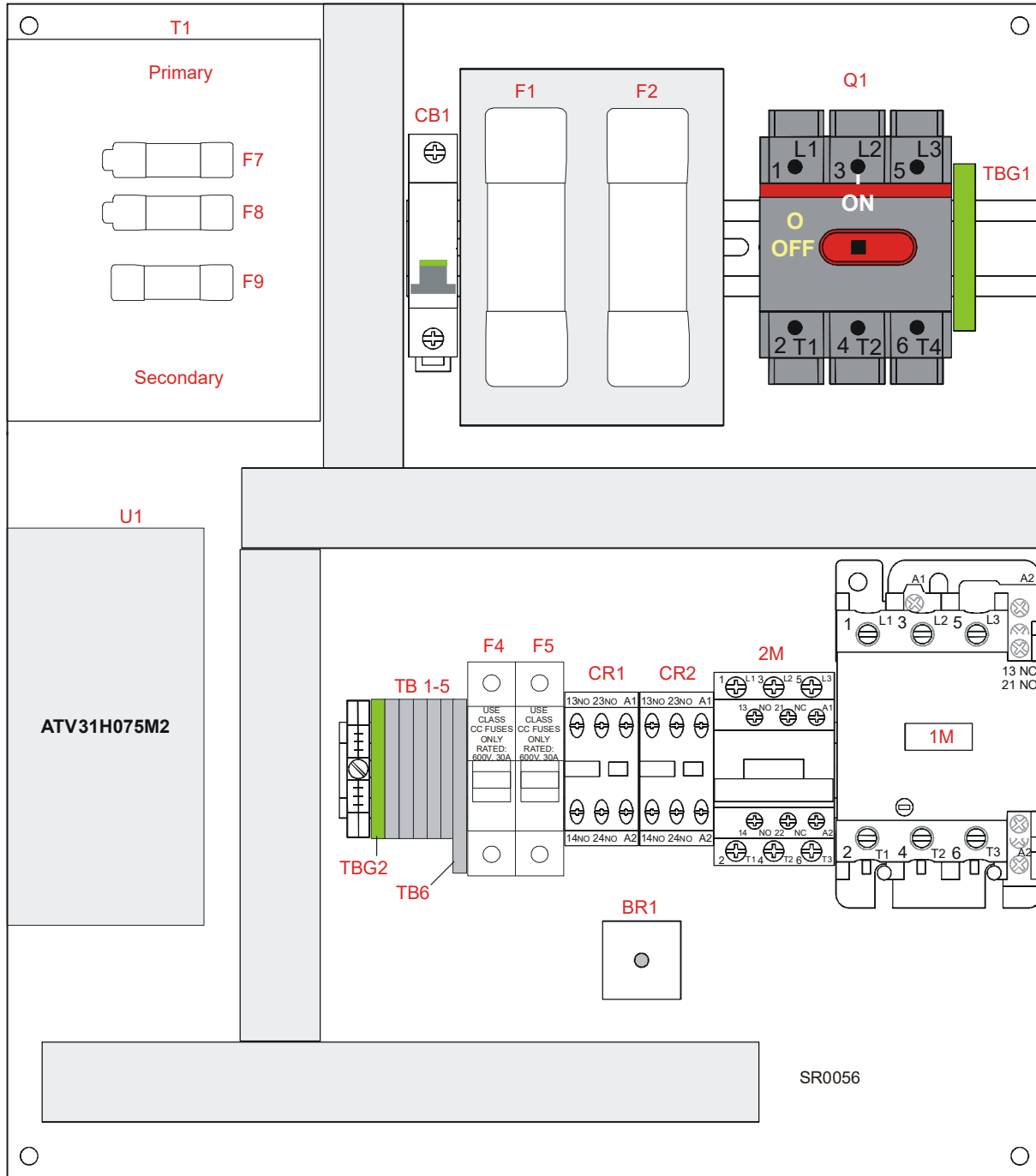

FIG. 6-7

Control Box Door Panel

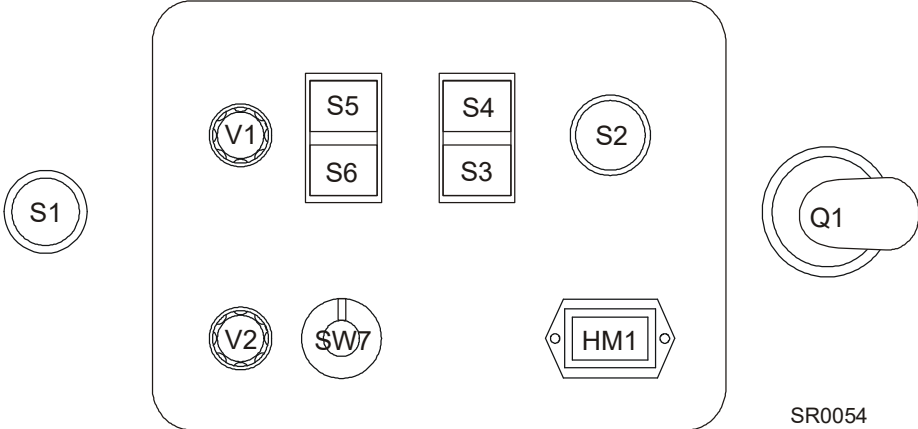

FIG. 6-7