

# BMT200/250



## ALIGNMENT & CALIBRATION QUICK START GUIDE

*A Supplement to the BMT200/250 Operator's Manuals*

### IMPORTANT!

This *Quick Start Guide* does **not** replace the need to **read the manuals**. This is only a guide to remind you of the basics involved with owning and operating your equipment.

# Table of Contents

# Section-Page

<b>SECTION 1</b>	<b>INTRODUCTION</b>	<b>1-1</b>
1.1	About This Quick Start Guide .....	1-1
1.2	Safety .....	1-1
1.3	Customer Service .....	1-4
1.4	Dimensions and Specifications .....	1-5
<b>SECTION 2</b>	<b>TOOTH SET GAUGE</b>	<b>2-1</b>
2.1	Tooth Set Gauge Calibration .....	2-1
2.2	Tooth Set Measurement .....	2-2
<b>SECTION 3</b>	<b>SETTER OPERATION</b>	<b>3-1</b>
3.1	Setter Alignment .....	3-1
	<i>The setter is properly aligned and ready for the Calibration Process when: ....</i>	<i>3-6</i>
4.2	Setter Calibration .....	4-1
	<i>Calibrate with tooth set gauge .....</i>	<i>4-1</i>
	<i>Calibrate on the setter .....</i>	<i>4-2</i>

# SECTION 1 INTRODUCTION

## 1.1 About This Quick Start Guide



**CAUTION!** This *Quick Start Guide* does **not** replace the need to **read the manuals**. This is only a guide to remind you of the basics involved with owning and operating your setter.

This Quick Start Guide is designed to serve as a reminder of the basic contents of the manuals. It is assumed that you have read the Operator's Manual and understood the safety notices that go with the individual sections. Deeper explanations of each operation are found in the manuals.

**NOTE:** Optional equipment may appear in the illustrations.

## 1.2 Safety

The following symbols and signal words call your attention to instructions concerning your personal safety. Be sure to observe and follow these instructions.



**DANGER!** indicates an imminently hazardous situation which, if not avoided, will result in serious injury or death.



**WARNING!** suggests a potentially hazardous situation which, if not avoided, could result in serious injury or death.



**CAUTION!** refers to potentially hazardous situations which, if not avoided, may result in minor or moderate injury or damage to equipment.



**IMPORTANT!** indicates vital information.

Read and observe all safety instructions before operating this equipment! Also read any additional manufacturer's manuals and observe any applicable safety instructions including dangers, warnings, and cautions.

Always be sure that all safety decals are clean and readable. Replace all damaged safety decals to prevent personal injury or damage to the equipment. Contact your local distributor, or call your Customer Service Representative to order more decals.

### ***Electrical Safety (Optional Auto Feed Only)***



**DANGER!** Make sure all electrical installation, service and/or maintenance work is performed by a qualified electrician and is in accordance with applicable electrical codes.





**DANGER!** HAZARDOUS VOLTAGE can cause shock, burns, or death. SHUT OFF & LOCK OUT POWER before performing service in any area of this machine. DO NOT restore power until all access panels are replaced and secured.



**WARNING!** Always turn off and disconnect power at control console AND at main supply circuit breaker before performing any service to the machine.

**Blade Handling**

 **WARNING!** Always wear gloves and eye protection when handling bandsaw blades. Keep all persons away from area when coiling or carrying a blade.

 **WARNING!** Before installing the blade, inspect it for damage and cracks. Always handle the blade with extreme care. Use suitable carrier equipment for transporting the blades.

**Machine Operation**

 **DANGER!** Make sure all guards and covers are in place and secured before operating the toothsetter. Failure to do so may result in serious injury.

 **DANGER!** Keep all persons away from moving parts when operating this machine. Failure to do so will result in serious injury.

 **DANGER!** Always keep hands away from moving bandsaw blade. Failure to do so will result in serious injury.

 **WARNING!** Always wear eye protection when operating this machine. Failure to do so may result in serious injury.





 **WARNING!** Secure all loose clothing and jewelry before operating this machine. Failure to do so may result in serious injury or death.

 **WARNING!** The toothsetter should be operated only by adults who have read and understood the entire operator's manuals.

 **WARNING!** The illumination at the operator's position should be at least 300 lux. The light source can not cause stroboscopic effect.

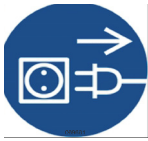
 **WARNING!** If at any time you need to immediately stop the machine, press the Emergency Stop (E-Stop) button. Before operating the machine again, turn the E-Stop button clockwise to release. The machine will not start until the E-Stop button is released.



**Dual Toothsetter Decals**

Decal	Part Number	Description
	069680	<p><b>WARNING!</b> Secure all loose clothing and jewelry before operating this machine. Failure to do so may result in serious injury or death.</p> <p><b>WARNING!</b> Always wear gloves and eye protection when handling bandsaw blades.</p> <p><b>WARNING!</b> Read the entire Operator's Manual before operating the equipment. Take notice of all safety warnings throughout this manual and those posted on the equipment. Keep this manual with this equipment at all times, regardless of ownership.</p>
	069681	<p><b>WARNING!</b> Always turn off and disconnect power at control console AND at main supply circuit breaker before performing any service to the machine.</p>
	069682	<p><b>DANGER!</b> HAZARDOUS VOLTAGE can cause shock, burns, or death. SHUT OFF &amp; LOCK OUT POWER before performing service in any area of this machine. DO NOT restore power until all access panels are replaced and secured.</p>
	069685	<p><b>WARNING!</b> Read the entire Operator's Manual before operating the equipment. Take notice of all safety warnings throughout this manual and those posted on the equipment. Keep this manual with this equipment at all times, regardless of ownership.</p>
	S20097	Motor Rotation Direction (Automatic Dual Toothsetter Only)
	053583	Manual Crank Feed Direction (Manual Dual Toothsetter Only)

# 1

## Introduction

### Customer Service

	P85070	CE Safety Certification
	069693	<b>DANGER!</b> Always be aware of and take proper protective measures against rotating shafts, pulleys, fans, etc. Always stay a safe distance from rotating members and make sure that loose clothing or long hair does not engage rotating members resulting in possible injury.

## 1.3 Customer Service

### Wood-Mizer Locations

#### USA World Headquarters

*Serving North & South America, Oceania, East Asia*

Wood-Mizer LLC  
8180 West 10th Street  
Indianapolis, IN 46214

Phone: 317.271.1542 or 800.553.0182  
Customer Service: 800.525.8100  
Fax: 317.273.1011  
Email: [infocenter@woodmizer.com](mailto:infocenter@woodmizer.com)

#### Canada Headquarters

*Serving Canada*

Wood-Mizer Canada  
396 County Road 36, Unit B  
Lindsay, ON K9V 4R3

Phone: 705.878.5255 or 877.357.3373  
Fax: 705.878.5355  
Email: [ContactCanada@woodmizer.com](mailto:ContactCanada@woodmizer.com)

#### Brazil Headquarters

*Serving Brazil*

Wood-Mizer do Brasil  
Rua Dom Pedro 1, No: 205 Bairro: Sao Jose  
Ivoti/RS CEP:93.900-000

Tel: +55 51 9894-6461/ +55 21 8030-3338/ +55 51  
3563-4784  
Email: [info@woodmizer.com.br](mailto:info@woodmizer.com.br)

#### Europe Headquarters

*Serving Europe, Africa, West Asia*

Wood-Mizer Industries Sp z o.o.  
Nagorna 114  
62-600 Kolo, Poland

Phone: +48.63.26.26.000  
Fax: +48.63.27.22.327

#### Branches & Authorized Sales Centers

For a complete list of dealers, visit [www.woodmizer.com](http://www.woodmizer.com)

## 1.4 Dimensions and Specifications

See Figure 1-1.

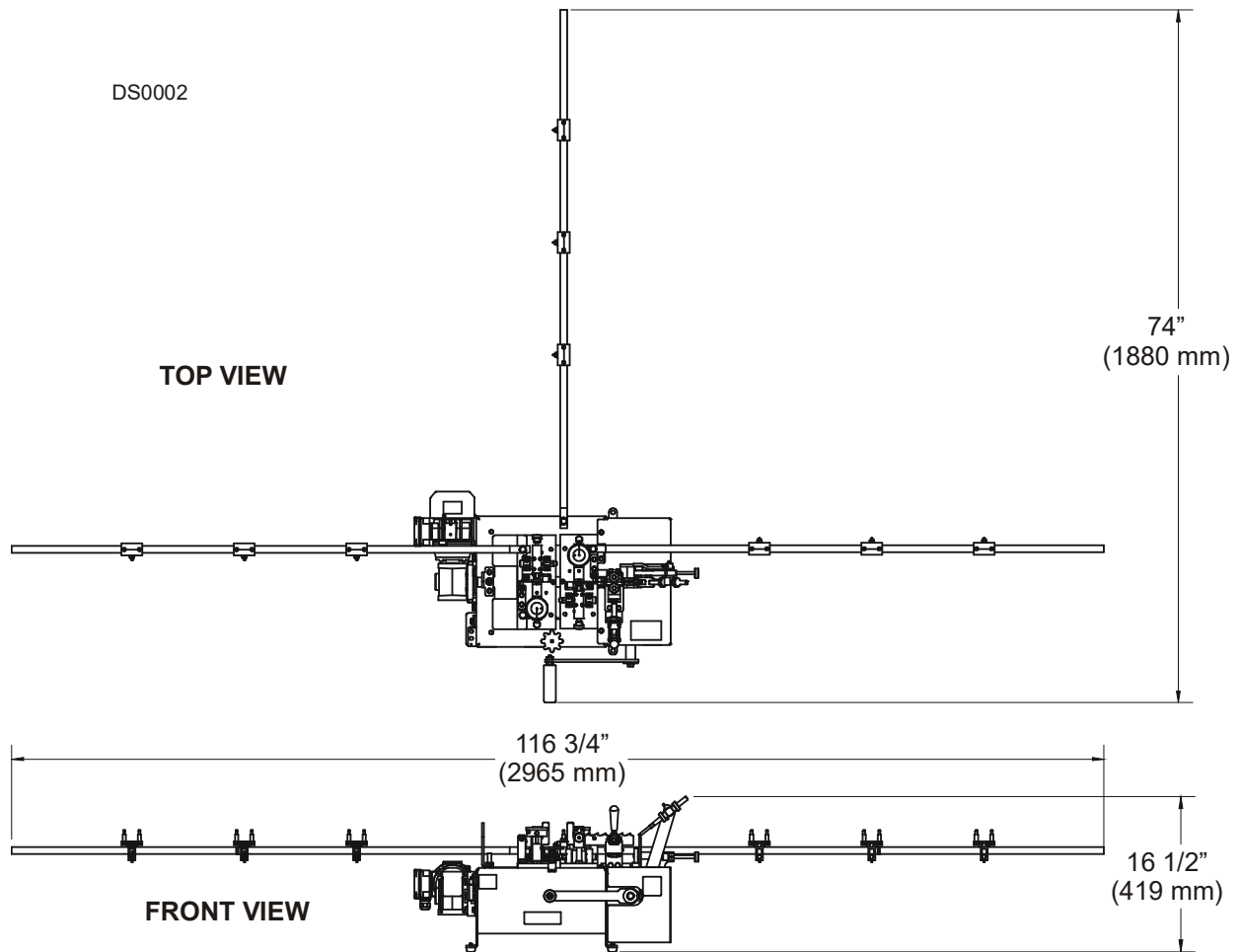

FIG. 1-1

	Length	Width	Height	Weight
<b>BMT200</b>	74" (1880 mm)	116 3/4" (2965 mm)	16 1/2" (419 mm)	90 lbs. (41 kg)
<b>BMT250</b>	74" (1880 mm)	116 3/4" (2965 mm)	16 1/2" (419 mm)	105 lbs. (47.5 kg)

## SECTION 2 TOOTH SET GAUGE

### 2.1 Tooth Set Gauge Calibration

1. Insert the dial gauge assembly into the hole in the block housing.
2. Clamp the calibrating pin in position at the center of the dial gauge foot.
3. Push the gauge assembly forward until the foot just touches the pin and dial needle moves 0.005 to 0.010.
4. Tighten the locking screw with the provided hex wrench (do not overtighten).
5. Loosen the dial lock on the gauge, rotate the dial face until the needle reads zero, and retighten.
6. Unclamp the calibrating pin from the clamp by turning the clamp knob counterclockwise.

The gauge needle should read between -0.005 and -0.010.

See Figure 2-1.

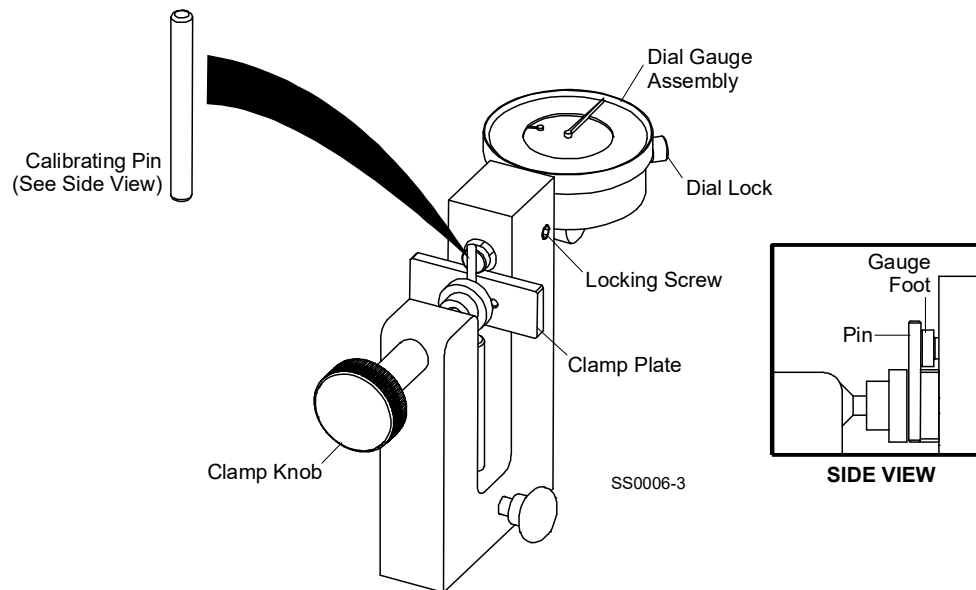

FIG. 2-1

7. If not, reclamp the pin, loosen the locking screw and move the gauge assembly back so the foot does not contact the pin.



8. Repeat the steps above until the dial needle reads zero with the calibrating clamped and between  $-0.005$  and  $-0.010$  without the pin clamped.
9. This insures the dial foot extends beyond the clamp plate a slight amount and will read zero when the foot is aligned with the clamp plate.

## 2.2 Tooth Set Measurement

1. Place the gauge around the blade.
2. Loosen the lock knob (counterclockwise) and adjust the blade height rest pin up or down.
3. When the blade rests on the pin, the gullet of the blade aligns just below the clamp plate.
4. Retighten the lock knob.

See Figure 2-2.

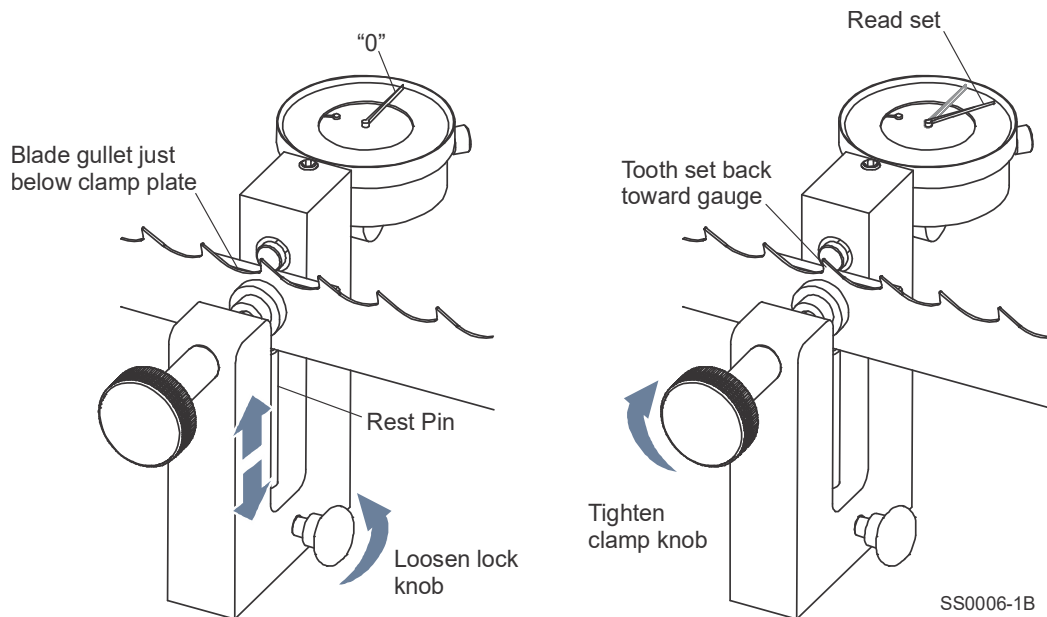

FIG. 2-2

5. Slide the blade through the gauge assembly until a tooth set back toward the gauge is positioned in front of the dial plunger.
6. Turn the clamp knob clockwise to securely clamp the blade and read the set measurement displayed by the gauge.
7. Loosen the clamp knob, remove the gauge assembly from the blade and rotate the gauge to the other side of the blade to measure teeth set in the opposite direction.

## SECTION 3 SETTER OPERATION

For calibration and alignment videos, refer to your DVD shipped with this manual, or look online at

[https://www.youtube.com/watch?v=eHWjGntODr8&ab\\_channel=Wood-Mizer](https://www.youtube.com/watch?v=eHWjGntODr8&ab_channel=Wood-Mizer)

### 3.1 Setter Alignment

Wood-Mizer blades have a raker-style set in the teeth. If you look at a blade from the top, you will see that the teeth are set (bent out) in a repeating sequence; left, right, and straight. The left and right teeth do the cutting. The straight teeth (rakers) clear the cut of sawdust. The setting process creates the clearance needed for the body of the blade to slide through the timber without dragging.

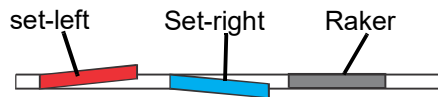

FIG. 3-1



**IMPORTANT!** A correct set of the blade is very important to the blade's cutting ability. Check used blades regularly to see if they need resetting.

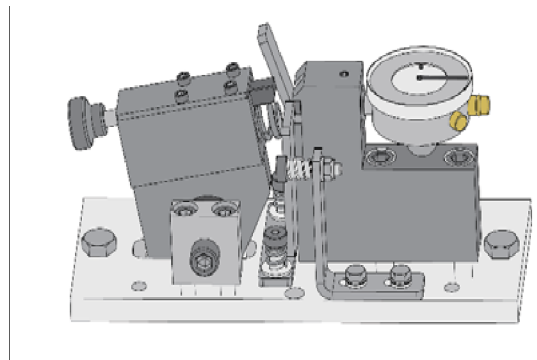

FIG. 3-2

1. Open the blade clamp handle (down) and flip the index arm up.

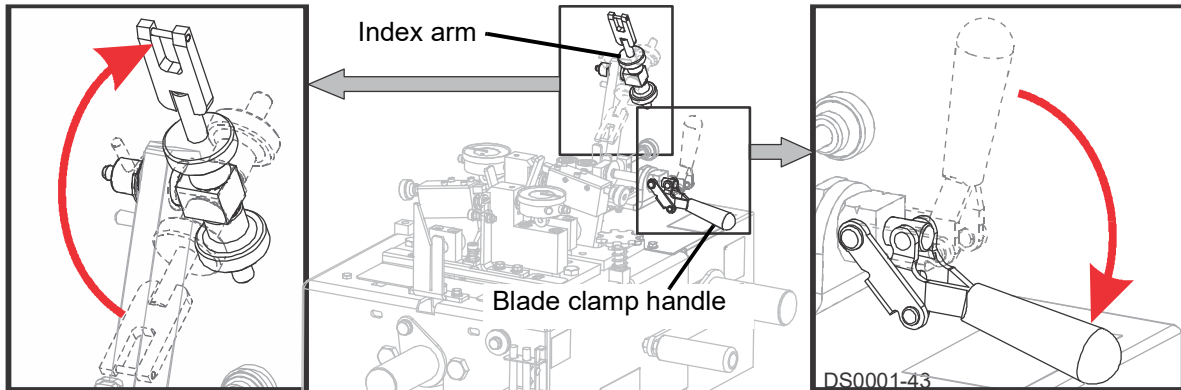

FIG. 3-3

2. Advance the blade feed (without the blade) until the setter assemblies are open.

For the manual setter, turn the feed handle counterclockwise; for automatic setters, set the feed switch to JOG (hand symbol) and press and hold the START button.

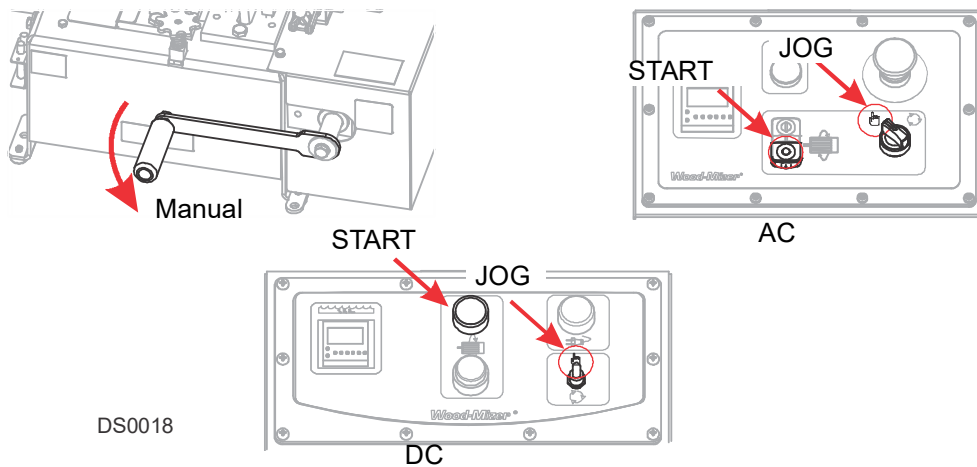

FIG. 3-4

3. Insert the blade by looping it over the setter and positioning it between the posts of the blade support guides. Place the blade between the clamp rollers and between the setter blocks, resting on the blade height adjustment pins.

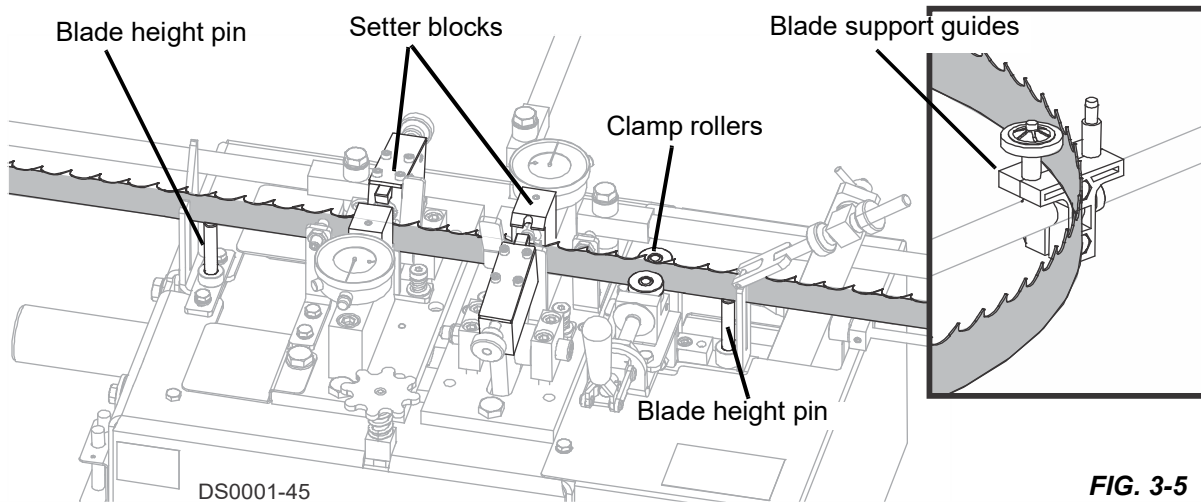

FIG. 3-5

4. Adjust the blade height pins so the gullet of the tooth is positioned approximately flush with each setter clamp plate.

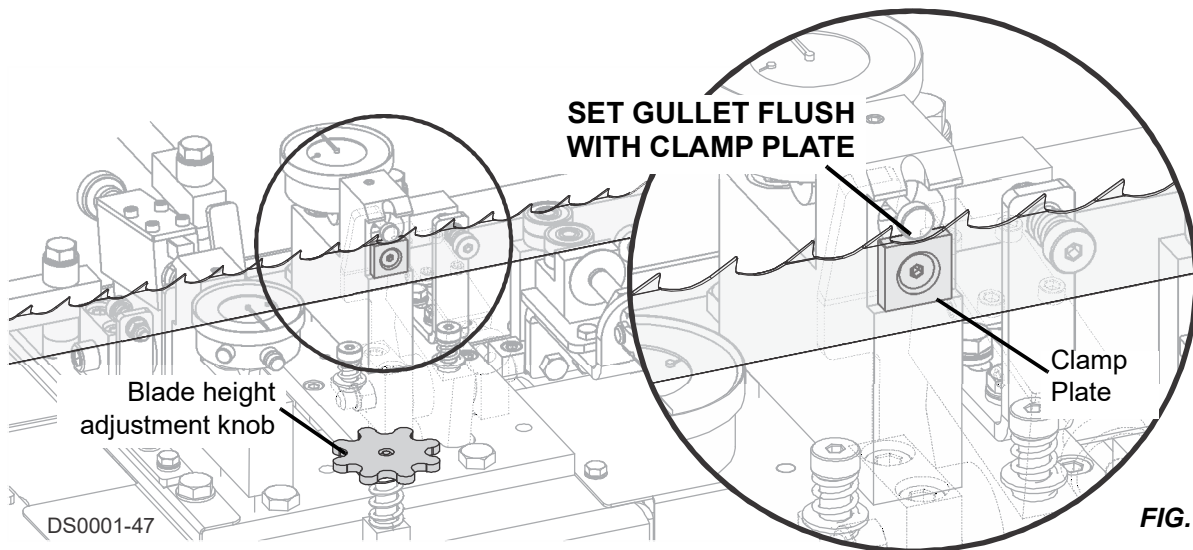

FIG. 3-6

5. Close the blade clamp handle and flip the index arm down into the blade (reverse Step 1.)
6. Advance the blade feed until the index arm pushes the blade forward.

For the manual setter, turn the feed handle counterclockwise; for automatic setters, set the feed switch to JOG (hand symbol) and press and hold the START button. (See Figure 3-4.)

7. Stop the feed before the setter assemblies start to close.
8. Open the blade clamp handle and flip the index arm up.
9. On the **right setter**, adjust the blade until a "set-left" tooth is positioned **just right of center** in relation to the set block; close the blade clamp handle.

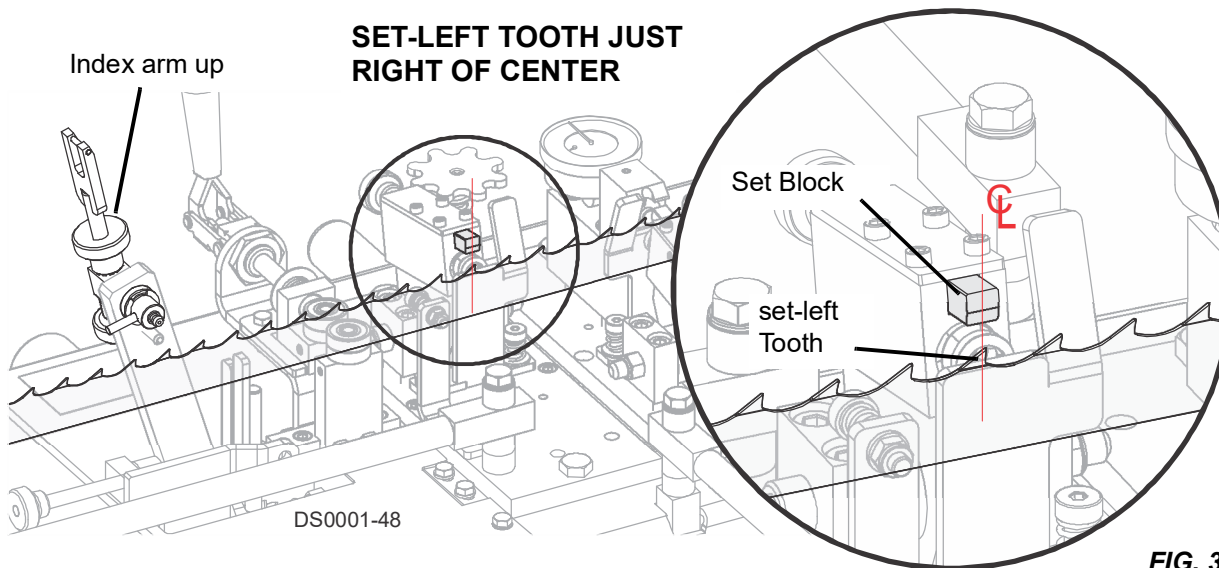

FIG. 3-7

10. While holding the index arm so it does not push the blade forward, advance the setter until the index arm has advanced as far as it can go.
11. Drop the index arm onto the blade and adjust the index arm so it is tight in the gullet of the tooth.

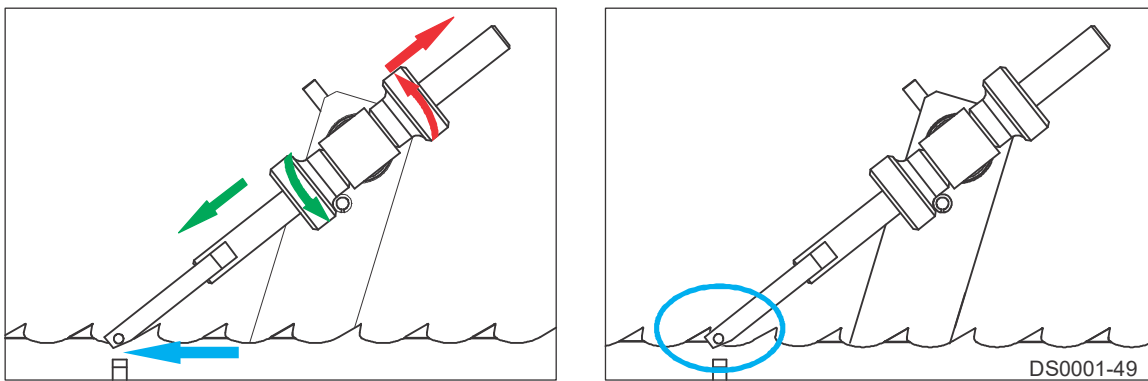

FIG. 3-8

12. Jog the blade forward to ensure the next tooth is properly aligned with the setter block. If the tooth is slightly out of position, make small adjustments with the index arm until the teeth consistently line up with the setter block.
13. Adjust the **left setter** assembly to match a "set-right" tooth by loosening the two mounting bolts and sliding the assembly.

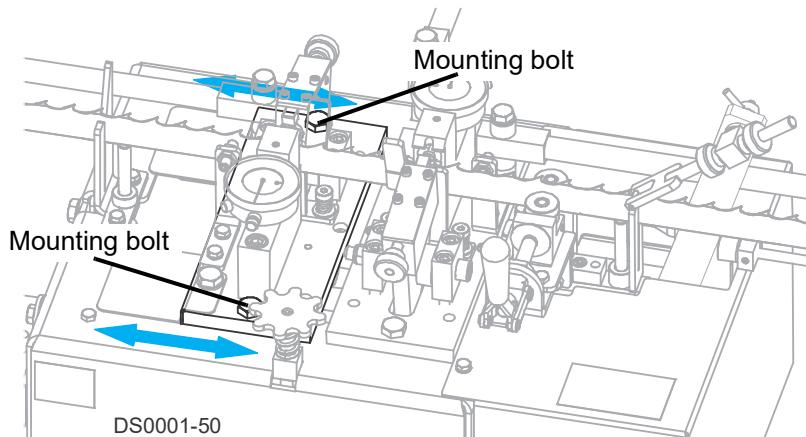

FIG. 3-9

14. Retighten the bolts when the "set-right" tooth is aligned with the setter block.
15. Move the blade forward.

The index arm should push forward three teeth from the previous one that was indexed.

16. Adjust the number of teeth the index arm picks up before pushing the blade forward by adjusting the backstop; turn the knob in to decrease return travel, or turn the knob out to increase travel.

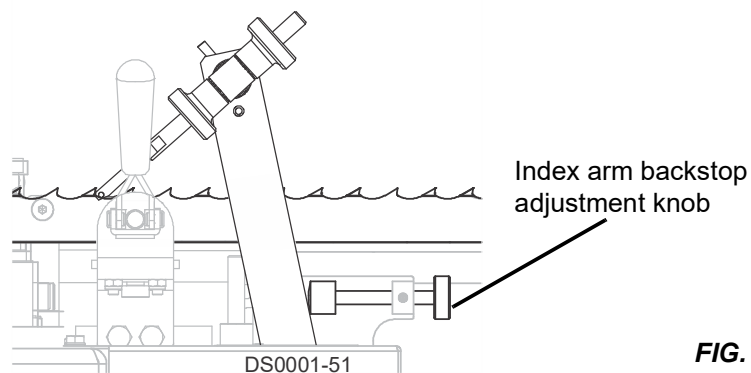
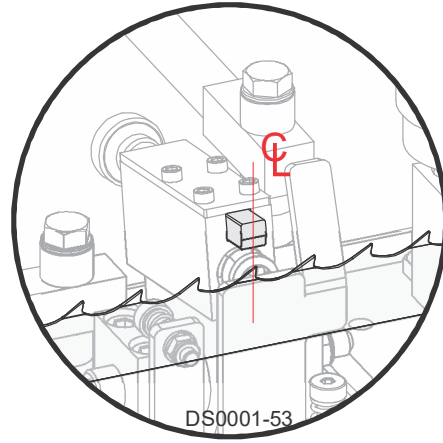
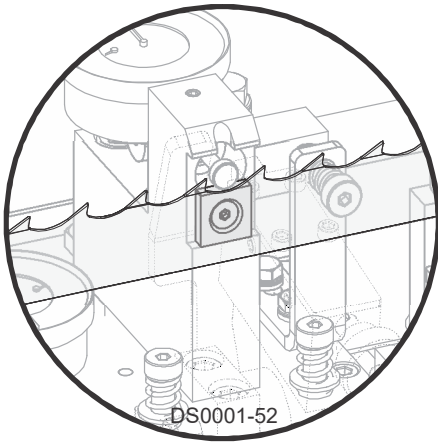

FIG. 3-10

**The setter is properly aligned and ready for the Calibration Process when:**

1. The gullet of the blade is flush with the setter clamp plate.
2. The tooth of the blade is just right of center on the pusher block.



3. The Index arm pushes the blade forward the correct amount of teeth.

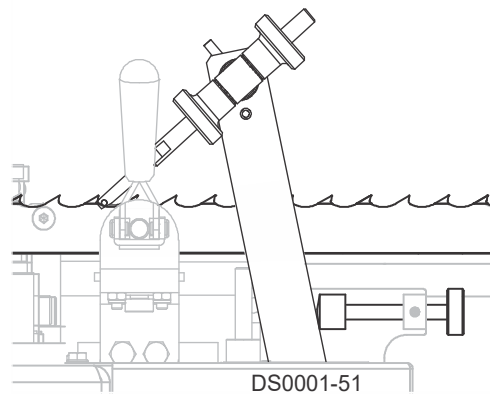

## 4.2 Setter Calibration



**IMPORTANT!** The Setter needs to be aligned before calibration.

Calibrating the BMT 200/250 is an essential step to ensure accurate setting of Wood-Mizer blades. Cutting performance is greatly increased using a blade that is accurately set.

### Calibrate with tooth set gauge

1. Select a “set-left” tooth that is to the left of the setter machine.

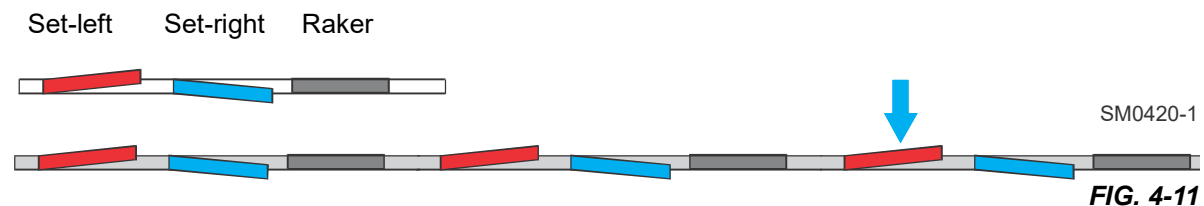

Note that set-left teeth are pointing towards the inside of the blade.

2. Bring the gullet of the blade flush with the clamp.
3. Tighten the clamp onto the blade to get the measurement.

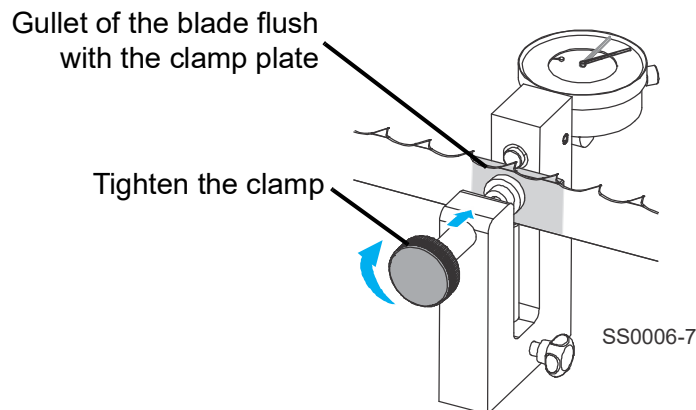

4. Record the measurement and mark the tooth for reference.



- Before releasing the clamp, raise the rest pin to the bottom of the blade to create a reference for the blade height.

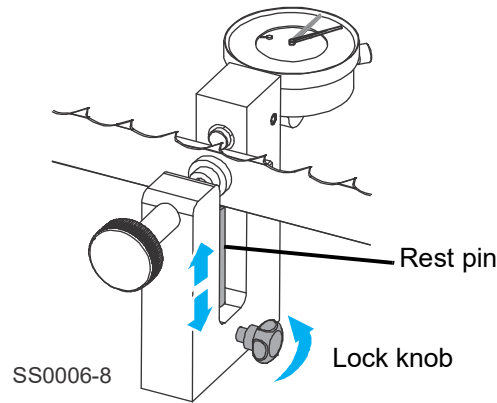

FIG. 4-13

- Count 5 teeth (for 7/8" & 1-1/8" tooth spacing) or 8 teeth (for 1/2", 5/8", & 3/4" tooth spacing) from the marked tooth.

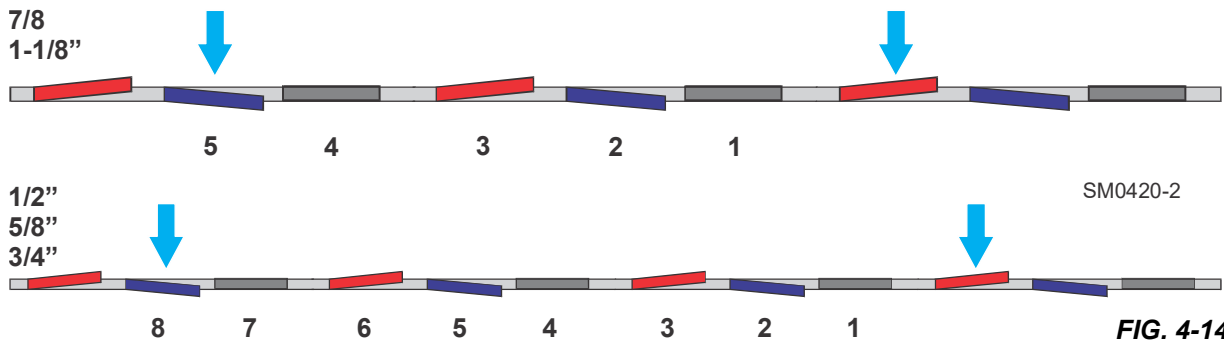

FIG. 4-14

- Measure and record the "set-right" tooth (tip pointing towards the outside of the blade) with the master gauge as described in steps 2 through 4.

**Calibrate on the setter**

- Align the marked reference teeth in the setter assemblies.

9. Clamp the blade.

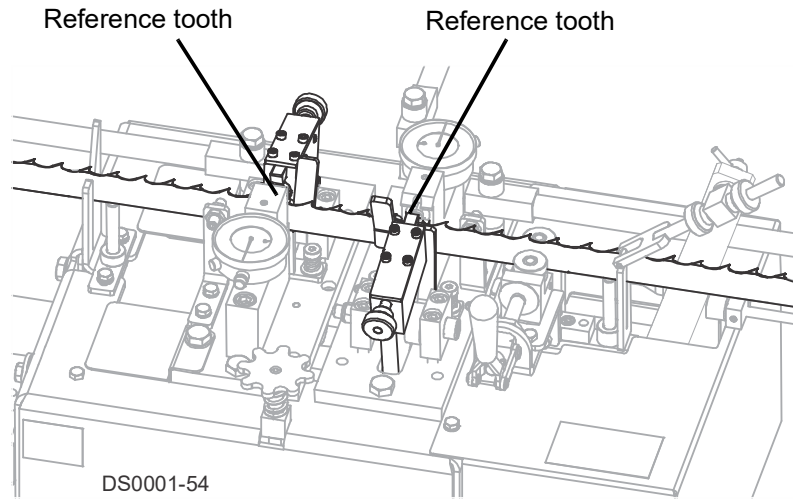

FIG. 4-15

10. Adjust the knobs on the setter assemblies to back off the setter blocks completely.

The blocks must be pushed in manually because they are not spring loaded. Be sure the blocks are backed off far enough so they will not contact the blade when you advance the blade in the next step.

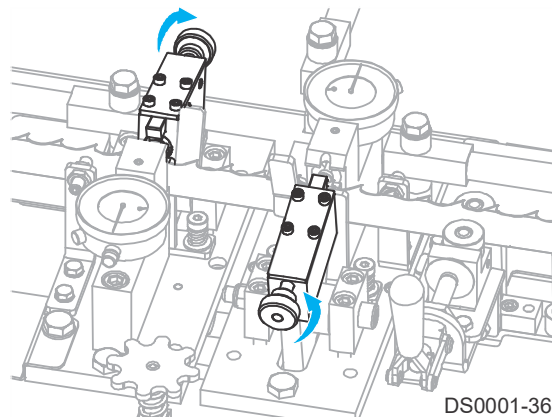
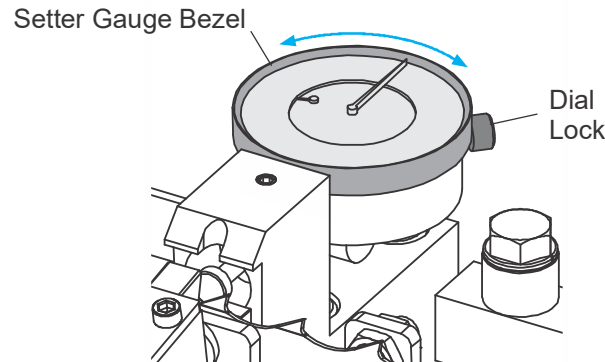

FIG. 4-16

11. Advance the blade until the setter assemblies are closed.

- Unlock the dial lock and adjust the setter gauge bezels so the needle of the gauges show the same tooth set measurements taken previously with the set master gauge.



DS0001-38

FIG. 4-17

Once the setter is calibrated you can now accurately adjust the set of the blade.

- Use the “tabs” on the gauge to bracket the desired set; typical deviation is two thousandths.

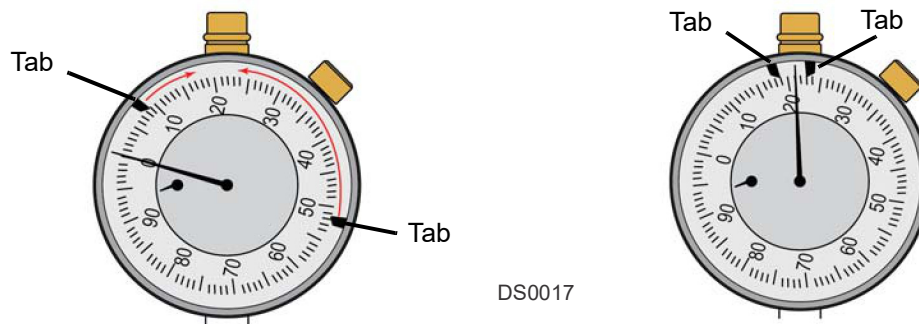

DS0017

FIG. 4-18

- Adjust the blade set by adjusting the knob on the setter to bring the setter block in.

Make small adjustments on both knobs while the setter is running. During operation, the actual set measurement will show when the gauge needle pauses for the **second** time and “hesitates”.

- Continue adjusting until the measurement is reached and the needle hesitates between the tabs.

**TIP:** With a properly aligned and calibrated setter--assuming that both sides of the set only need a minor adjustment to achieve the desired set--it is quicker and easier to raise or lower the blade using the blade height adjustment knob.

- Raising the blade will increase the set achieved.
- Lowering the blade will reduced the set achieved.