

**Wood-Mizer® PC100 Upcut Saw**  
**Safety, Setup, Operation,**  
**Maintenance and Parts**

---

PC100

rev. A1.02

---

***Safety is our #1 concern!***

*Form #2478*

**MODELS EFFECTED:**

PC100EA10-LH  
PC100EB10-LH  
PC100EC10-LH  
PC100EA10-RH  
PC100EB10-RH  
PC100EC10-RH



**WARNING! Read and understand this manual before using this machine.**

## California

### Proposition 65 Warning



**WARNING:** Drilling, sawing, sanding or machining wood products can expose you to wood dust, a substance known to the State of California to cause cancer. Avoid inhaling wood dust or use a dust mask or other safeguards for personal protection.

For more information go to **[www.P65Warnings.ca.gov/wood](http://www.P65Warnings.ca.gov/wood)**.

### Active Patents assigned to Wood-Mizer, LLC

Wood-Mizer, LLC has received patents that protect our inventions which are a result of a dedication to research, innovation, development, and design. Learn more at: [woodmizer.com/patents](http://woodmizer.com/patents)

### ©January 16, 2024 Wood-Mizer LLC

Printed in the United States of America, all rights reserved. No part of this manual may be reproduced in any form by any photographic, electronic, mechanical or other means or used in any information storage and retrieval system without written permission from

**Wood-Mizer, LLC**

**8180 West 10th Street**

**Indianapolis, Indiana 46214**

**SECTION 1 INTRODUCTION**

1.1 About This Manual ..... 1-1  
 1.2 Getting Service..... 1-1  
 1.3 Specifications ..... 1-1  
 1.4 Configurations..... 1-1  
 1.5 Options and Accessories ..... 1-1

**SECTION 2 GENERAL SAFETY**

2.1 Safety Symbols ..... 2-1  
 2.2 Safety Instructions..... 2-1  
 2.3 Electrical Lockout Procedures ..... 2-2  
 2.4 Safety Labels Description ..... 2-3

**SECTION 3 PC100 SETUP**

3.1 Site Preparation ..... 3-1  
 3.2 Uncrate and Prepare Parts ..... 3-1  
 3.3 Position PC100 for Installation ..... 3-1  
 3.4 Dust Collection ..... 3-1  
 3.5 Check Drive Belt Tension ..... 3-2  
 3.6 Initial Control Valve Adjustments ..... 3-2  
 3.7 Electrical ..... 3-2  
 3.8 Reinstall Fence ..... 3-3  
 3.9 Blade Travel Adjustments..... 3-3

**SECTION 4 PC100 ACCESSORY SETUP**

4.1 Overview ..... 4-1  
 4.2 Assemble Legs and Brackets ..... 4-1  
 4.3 Install Tables ..... 4-2  
 4.4 Install Table Supports ..... 4-2  
 4.5 Align and Level Tables ..... 4-3  
 4.6 Install Scale Decals ..... 4-3  
 4.7 Optional Reclaimed Lumber Dust Chute ..... 4-4

**SECTION 5 OPERATION**

5.1 Operation..... 5-1

**SECTION 6 MAINTENANCE**

6.1 Sawdust Removal..... 6-1  
 6.2 Blade Inspection..... 6-1  
 6.3 Blade Replacement ..... 6-1  
 6.4 Belt Inspection ..... 6-2  
 6.5 Drain Water Separator ..... 6-2  
 6.6 Lubrication ..... 6-2  
 6.7 Replace Clamp Pads..... 6-2

**SECTION 7 PARTS**

7.1	How To Use The Parts List .....	7-1
7.2	Sample Assembly .....	7-1
8.3	Overview .....	8-1
8.4	Cabinet Assembly.....	8-2
8.5	Dust Chute Components.....	8-4
8.6	Inside Cabinet.....	8-5
8.7	Pivot Assembly .....	8-6
8.8	Cylinder Assembly .....	8-8
8.9	Shock Absorber Assembly .....	8-9
8.10	3 Phase Motor Assembly.....	8-10
8.11	1 Phase Motor Assembly.....	8-11
8.12	Table Top Assembly.....	8-12
8.13	Height Adjustment Assembly.....	8-13
8.14	Air Prep Assembly .....	8-14
8.15	Clamp-Guard Assembly .....	8-15
8.16	Operator Control Assembly.....	8-17
8.17	Electrical Box Assembly .....	8-18
8.18	Decals PC100 .....	8-19
8.19	Infeed Table (Optional) .....	8-20
8.20	Outfeed Table (Optional) .....	8-21
8.21	Outfeed Table Add-on (Optional) .....	8-22
8.22	Outfeed Stops .....	8-23
8.23	Gang Stop (Optional) .....	8-24
8.24	Lower Chute Bracket Kit (Optional).....	8-25

**SECTION 8 TROUBLESHOOTING**

# Wood-Mizer® LLC Limited Product Warranty



Wood-Mizer LLC ("Warrantor"), an Indiana corporation with its principal place of business at 8180 West Tenth Street, Indianapolis, IN 46214-2400 USA, warrants to the purchaser ("Purchaser") that for the time periods specifically stated herein and subject to the terms, conditions and limitations stated herein, the equipment manufactured by the Warrantor will be free from defects in material and workmanship attributable to Warrantor so long as, during the warranty periods stated herein, the equipment is installed, operated and maintained in accordance with the instructions provided by Warrantor.

PRODUCT	MODEL CLASS	LENGTH OF WARRANTY		EFFECTIVE DATE
		USA & CANADA	NON USA & CANADA	
Portable Sawmills, Resaws, Edgers	LT, LX, HR, EG	Two years	One year	Date of purchase
Portable Sawmills with Chassis	LT28, LT35, LT40, LT50, LT70, LX450	Two years, excluding the chassis, which chassis shall have a five year warranty	One year	
Industrial Sawmills, Resaws, Edgers	WM, HR, EG, TVS, SVS	One year	One year	Date of purchase or date of installation / training (if applicable), whichever occurs first, not to exceed 6 months from date of purchase
TITAN Industrial	WB, TV, HR, EG, EA, MR	One year	One year	
Material Handling	TWC, IC, TD, LD, GC, CR, CB, CC	One year	One year	
Blade Maintenance Equipment	BMS, BMT, BMST	One year	One year	Date of purchase
Options and Accessories	Various	One year*	One year*	
Moulders, Extractors	MP, MD	Two years	One year	
Kilns	KS, KD	One year	One year	
Slab Flattener	MB	Two years	One year	
Pallet Equipment	PD, PC	One year	One year	
Log Splitters	FS	One year	One year	
Replacement Parts	Various	90 days	90 days	

\* Warranty on Options will match the warranty on the primary equipment when purchased on same invoice.

## Exclusions from 90 Day, Limited One Year and Two Year Warranty

Warrantor shall have **no** responsibility under this warranty for any wear components, including, but not limited to: belts, blade guides, blades, electric motor brushes, drum switches, filters, fuses, hoses, bearings (excluding cylindrical drive bearings), bushings, cable carriers, and spark plugs. All wear components are furnished "as is", without any warranty from Warrantor. This limited warranty does not cover any defects caused by misuse, negligence, alterations, damage due to overload, abnormal conditions, excessive operation, accident, or lack of performance of normal maintenance services.

Several components which are used in the manufacture of the equipment but not manufactured by Warrantor such as cant hooks, power plants, laser sights, batteries, tires, and trailer axles have warranties provided by the original equipment manufacturer (written copies available upon request). Warrantor does not separately warrant such items. Components or equipment manufactured by third parties are not covered by this warranty. Warrantor, however, will provide reasonable assistance to the Purchaser to make claims against any warranties applicable to such component parts as provided by such original equipment manufacturers. Components or equipment manufactured by third parties are not covered by this Warranty.

## Five Year Limited Chassis Warranty

The limited five year chassis warranty described above, DOES NOT extend to (a) any damage stemming from accident, improper towing, overload, abuse, misuse, abnormal conditions, negligence, excessive operation, or lack of maintenance, (b) rust caused by exposure to corrosive atmospheric conditions, or (c) the sawmill head, carriage, axle, brakes, or any hydraulic or electrical components attached to the chassis.

## Warrantor's Obligations as To Defects

In the event that the equipment fails to perform due to defective materials or workmanship attributable to Warrantor under normal use and service within the established warranty period, Purchaser's sole and exclusive remedy and Warrantor's sole liability shall be to replace or repair, in Warrantor's sole and subjective discretion, any defective part at Warrantor's principal place of business without cost to the Purchaser if such defect exists. The determination of whether a product is defective shall be made by Warrantor in Warrantor's sole and subjective discretion. The Purchaser must notify Warrantor prior to shipping any defective part. Warrantor, at its sole discretion, may cover expenses incurred in shipping the defective part to Warrantor for evaluation; provided, however, that Warrantor will not be responsible for labor, travel time, mileage, removal, installation or incidental or consequential damages. However, any part in excess of 140 pounds must be returned by the Purchaser, to the Warrantor's nearest authorized facility at the Purchaser's expense, if return is requested by Warrantor. Warrantor shall have a reasonable time within which to replace or repair the defective part. If Warrantor determines that the product is not defective under the terms of this warranty in Warrantor's sole and subjective discretion, then Purchaser shall be responsible for any expenses incurred by Warrantor in returning the equipment to the Purchaser.

## Limitations and Disclaimers of Other Warranties

EXCEPT FOR THE EXPRESS WARRANTY PROVISIONS STATED ABOVE, WARRANTOR DISCLAIMS ALL WARRANTIES, EXPRESS AND/OR IMPLIED, INCLUDING WITHOUT LIMITATION, THE IMPLIED WARRANTIES OF MERCHANTABILITY, AND FITNESS FOR A PARTICULAR PURPOSE, NON-INFRINGEMENT AND TITLE. No representation or other affirmation of fact by representatives of Warrantor, whether verbal or in writing, including photographs, brochures, samples, models, or other sales aids, shall constitute a warranty or other basis for any legal action against Warrantor. There are no other representations, promises, agreements, covenants, warranties, guarantees, stipulations or conditions, express or implied, by Warrantor except as expressly set forth herein. THE ORIGINAL PURCHASER AND ANY INTENDED USER OR BENEFICIARY OF THIS EQUIPMENT, SHALL NOT BE ENTITLED TO RECOVER ANY INDIRECT, SPECIAL, PUNITIVE, EXEMPLARY, CONSEQUENTIAL, SPECIAL, OR INCIDENTAL DAMAGES OR LOSSES, INCLUDING BUT NOT LIMITED TO, DAMAGES OF LOST PRODUCTION, LOST REVENUE, LOST PRODUCT, LOST PROFITS, LOST BUSINESS, LOSS OF USE, LOSS OF GOODWILL, OR BUSINESS INTERRUPTION, FROM WARRANTOR FOR ANY REASON WHATSOEVER INCLUDING WITHOUT LIMITATION WARRANTY OR DEFECT IN THE PRODUCT REGARDLESS OF THE SOLE, JOINT AND/OR CONCURRENT NEGLIGENCE, BREACH OF CONTRACT, BREACH OF WARRANTY, STRICT LIABILITY IN TORT OR STATUTORY CLAIMS OR OTHER LEGAL FAULT OR RESPONSIBILITY OF EITHER WARRANTOR OR PURCHASER OR ITS EMPLOYEES OR AGENTS. Warrantor does not warrant that its equipment meets or complies with the requirements of any particular safety code or governmental requirements.

Defective items replaced under the terms of this warranty become the property of Warrantor.

## Design Changes

Warrantor reserves the right to change the design of its products from time to time without notice and without obligation to make corresponding changes in or to its products previously manufactured.

## Rights of Purchasers

The validity and effect of this limited warranty as well as its interpretation, operation and effect, shall be determined exclusively by the principles of law and equity of the State of Indiana, USA. This limited warranty gives Purchaser specific legal rights. Purchaser may also have other rights, which may vary from state to state. Some states may not allow limitations as to the duration of implied warranties or to the exclusion or limitation of incidental or consequential damages, so some of the limitations and exclusions detailed set forth above may not apply. In the event that any one or more of the provisions of this warranty shall be or become invalid, illegal or unenforceable in any respect, the validity, legality and enforceability of the remaining provisions of this warranty shall not be affected thereby.

## Interpretations

This Warranty constitutes the entire warranty agreement between Warrantor and Purchaser and supersedes any prior understandings or agreements pertaining to the same subject matter. This warranty cannot be amended except in writing which refers to this warranty which is signed by both Warrantor and Purchaser.

## SECTION 1 INTRODUCTION

### 1.1 About This Manual

This manual replaces any previous information received on your Wood-Mizer® equipment.

The information and instructions in this manual do not amend or extend the limited warranties for the equipment given at the time of purchase.

### 1.2 Getting Service

For contact information, sales, service, parts, and additional manuals, sign into your account on <https://woodmizer.com>, or call inside the USA: 1-800-553-0182 or from outside the USA: 317-271-1542

### 1.3 Specifications

Equipment specification are included in the Online Manuals, which are found at <https://apps.woodmizer.com/Manuals/Manuals.aspx?parent=0>.

### 1.4 Configurations

The PC100 is available in both Left- and Right-Hand feed configurations. This manual pictures the Left-Hand configu-

rations only. For Right-Hand configurations, operations are mirror opposites of what is shown.

**NOTE:** Where assemblies are unique to a specific configuration, they are noted by either LH or RH.

### 1.5 Options and Accessories

Your Wood-Mizer product may have options that can be added to the machine or accessories available to purchase. Different power configurations are also available.

**Option:** Your specific product can have accessories installed at the factory, or installed in the field.

**Accessory:** Your specific product may have accessories added to the machine that are not available to be installed at the factory. They may only be installed in the field. For example, the PC100 might have Infeed and Outfeed Table accessories.

**Power Options:** Your specific product power option is detailed based on the specific product number purchased.

This product has the following accessories available:

Part #	Name	Type
122371	Assembly, Infeed Table	Accessory
122372	Assembly, Outfeed Table	Accessory
134160	Assembly, Stringer Stop	Accessory
134189	Assembly, Gang Stop	Accessory
133437	Scale Decal, PC100 Dual Directional	Accessory
122324	Blade, 18"x60T, Circular, Carbide Tip	Accessory
122325	Blade, 18"x80T, Circular, Carbide Tip	Accessory
122326	Blade, 18"x120T, Circular, Carbide Tip	Accessory

**TABLE 1-1**

## SECTION 1 GENERAL SAFETY

### 2.1 Safety Symbols

The following symbols and signal words call your attention to instructions concerning your personal safety. Be sure to observe and follow these instructions.

 **DANGER!** indicates an imminently hazardous situation which, if not avoided, will result in serious injury or death.

 **WARNING!** suggests a potentially hazardous situation which, if not avoided, could result in serious injury or death.

 **CAUTION!** refers to potentially hazardous situations which, if not avoided, may result in minor or moderate injury or damage to equipment.

**NOTICE** indicates vital information.

### 2.2 Safety Instructions

#### OWNER/OPERATOR'S RESPONSIBILITY

The procedures listed in this manual may not include all ANSI, OSHA, or locally required safety procedures. **It is the owner/operator's responsibility and not Wood-Mizer LLC to ensure all operators are properly trained and informed of all safety protocols.** Owner/Operators are responsible for following all safety procedures when operating and performing maintenance to the equipment.

#### Observe ALL Safety Instructions

**NOTICE** Read the entire Operator's Manual before operating this equipment.

Note all safety warnings throughout this manual and those posted on the machine.

Be able to access this manual at all times while operating this equipment.

Read additional manufacturer's manuals and observe their applicable safety instructions.

Only persons who have read and understood the entire operator's manual should operate this equipment.

This equipment is not intended for use by or around children.

**It is the owner/operator's responsibility to comply with all applicable federal, state, and local laws, rules, and regulations regarding the ownership, operation, and transporting your equipment.**



Operators should become thoroughly familiar with and comply with these applicable laws for operating and transporting equipment.

#### WEAR SAFETY CLOTHING

 **WARNING!** Secure all loose clothing and jewelry before operating the saw.





Always wear eye, ear, and foot protection when operating the saw.



Wear hand protection while servicing the saw blades.

#### PC100 SETUP

 **DANGER!** Do not operate the saw without all covers and guards in place.

 **WARNING!** Set up the saw on solid, level ground.

Leave clearance around the machine for cabinet access, personnel, material handling, etc.

#### KEEP HANDS AWAY

 **DANGER!** Remove power before clearing debris or any other maintenance activity.

Never place your hands or tools above or beneath the machine table while the machine is running.

 **WARNING!** Avoid contact with any hot parts (motors).

**Allow the system to cool sufficiently before beginning any service function, including debris removal.**

Avoid contact with sharp edges of saw blades.

#### KEEP PC100 AND SURROUNDING AREA CLEAN

 **WARNING!** Maintain a clean and clear path for all necessary movement around the PC100 and material stacking areas.

Do not allow children in the area of the PC100.

#### PC100 BLADE USE AND MAINTENANCE

 **WARNING!** Ensure blades are free of cracks or other defects.

Do not use the saw if there is blade vibration.

Defective blades can stick, jam, kickback, or throw teeth.

## 2 General Safety

### Electrical Lockout Procedures

When connecting/reconnecting power to PC100, verify correct blade rotation prior to use.

Incorrect rotation will cause dangerous kickback.

**NOTE:** If incorrect rotation, swap any 1 of 3 incoming lines.



**CAUTION!** Keep blade free of gum buildup.

Excessive gum buildup can accentuate kickback.

#### ONLY USE RECOMMENDED ACCESSORIES



**CAUTION!** Accessories and attachments which are not specifically recommended for the PC100 may adversely affect safe usage.

#### DISPOSE OF WOOD BY-PRODUCTS PROPERLY

**NOTICE** Properly dispose of all wood by-products, including sawdust, chips, and other debris, including operation waste such as oil, filters, etc.

#### KEEP SAFETY LABELS IN GOOD CONDITION

**NOTICE** Ensure that all safety decals are clean and readable. Replace all damaged safety decals to prevent personal injury or damage to the equipment. Contact your local distributor, or call your Customer Service Representative to order more decals.

**NOTICE** If replacing a component that has a safety decal affixed to it, ensure the new component also has the safety decal affixed.

## 2.3 Electrical Lockout Procedures

### RULES FOR USING LOCKOUT PROCEDURE

The equipment shall be locked out to protect against accidental or inadvertent operation when such operation could cause injury to personnel. Do not attempt to operate any switch or valve bearing a lock.

### LOCKOUT PROCEDURES MUST BE USED DURING, BUT NOT LIMITED TO:

- Changing or adjusting blades
- Unjamming operations
- Cleaning
- Mechanical repair
- Electrical maintenance
- Retrieval of tools/parts from work area
- Activities where guards or electrical panel guard is open or removed

### MAINTENANCE HAZARDS INCLUDE, BUT NOT LIMITED TO:

- Blade contact
- Pinch points

- Kickbacks
- Missiles (thrown blades/wood chips)
- Electrical

### FAILURE TO LOCKOUT MAY RESULT IN, BUT NOT LIMITED TO:

- Cut
- Crush
- Blindness
- Puncture
- Electrocution
- Serious injury and death
- Amputation
- Burn
- Shock

### TO CONTROL MAINTENANCE DANGERS:

- Lockout procedures must be followed (see **OSHA regulation 1910.147**).
- Never rely on machine stop control for maintenance safety (emergency stops, on/off switches, interlocks).
- Do not reach into moving blades or feed systems. Allow all coasting parts to come to a complete stop.
- Electrical power supply and air supply must both be locked out.
- Where established lockout procedures cannot be used (electrical troubleshooting or mechanical dynamic troubleshooting), alternative effective protective techniques shall be employed which may require special skills and planning.
- Always follow safe operations practices in the workplace.

### EQUIPMENT LOCKOUT PROCEDURE

Lockout procedures per OSHA regulation 1910.147, appendix A:

#### GENERAL

The following simple lockout procedure is provided to assist owner/operators in developing their procedures so they meet the requirements of **OSHA regulation 1910.147**. When the energy isolating devices are not lockable, tagout may be used, provided the owner/operator complies with the provisions of the standard which require additional training and more rigorous periodic inspections. When tagout is used and the energy isolating devices are lockable, the owner/operator must provide full operator protection (see OSHA regulation 1910.147, paragraph (c)(3)) and additional training and more rigorous periodic inspections are required. For more complex systems, more comprehensive procedures may need to be developed, documented, and utilized.

#### PURPOSE

This procedure establishes the minimum requirements for the lockout of energy isolating devices whenever maintenance or servicing is done on machines or equipment. It shall be used to ensure that the machine or equipment is stopped, isolated from all potentially hazardous energy sources and locked out before personnel perform any ser-



vicings or maintenance where the unexpected energization or start-up of the machine or equipment or release of stored energy could cause injury.

**COMPLIANCE WITH THIS PROGRAM**

All personnel are required to comply with the restrictions and limitations imposed upon them during the use of lock-out. The authorized personnel are required to perform the lockout in accordance with this procedure. All operators, upon observing a machine or piece of equipment which is locked out to perform servicing or maintenance shall not attempt to start, energize, or use that machine or equipment.

**SEQUENCE OF LOCKOUT**

1. Notify all affected personnel that servicing or maintenance is required on a machine or equipment and that the machine or equipment must be shut down and locked out to perform the servicing or maintenance.
2. The authorized employee shall refer to the company procedure to identify the type and magnitude of the energy that the machine or equipment utilizes, shall understand the hazards of the energy, and shall know the methods to control the energy.
3. If the machine or equipment is operating, shut it down by the normal stopping procedure (depress the stop switch, open switch, close valve, etc.).
4. De-activate the energy isolating device(s) so that the machine or equipment is isolated from the energy source(s).
5. Lock out the energy isolating device(s) with assigned individual lock(s).
6. Stored or residual energy (such as that in capacitors, springs, elevated machine members, rotating fly-wheels, hydraulic systems, and air, gas, steam, or water pressure, etc.) must be dissipated or restrained by methods such as grounding, repositioning, blocking, bleeding down, etc.
7. Ensure that the equipment is disconnected from the energy source(s) by first checking that no personnel are exposed, then verify the isolation of the equipment by operating the push button or other normal operating control(s) or by testing to make certain the equipment will not operate.



**CAUTION!** Return operating control(s) to neutral or "off" position after verifying the isolation of the equipment.

8. The machine or equipment is now locked out.

**RESTORING EQUIPMENT TO SERVICE**

When the servicing or maintenance is completed and the machine or equipment is ready to return to normal operating condition, the following steps shall be taken.

1. Check the machine or equipment and the immediate area around the machine to ensure that nonessential

items have been removed and that the machine or equipment components are operationally intact.

2. Check the work area to ensure that all personnel have been safely positioned or removed from the area.
3. Verify that the controls are in neutral.
4. Remove the lockout devices and re-energize the machine or equipment.
 

**NOTE:** The removal of some forms of blocking may require re-energization of the machine before safe removal.
5. Notify affected personnel that the servicing or maintenance is completed and the machine or equipment is ready for use.

**PROCEDURE INVOLVING MORE THAN ONE PERSON**

In the preceding steps, if more than one individual is required to lock out the equipment, **each shall place his own personal lock** on the energy isolating devices.



**2.4 Safety Labels Description**

See table below for safety labels description.

**TABLE 2-1**

Label View	Description
	096317 CAUTION! Read and understand operator's manual before handling the machine.
	099220 Close guards prior to operating the machine

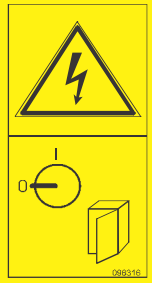
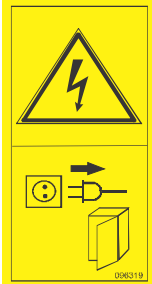
**TABLE 2-1**

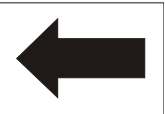
	<p>096316 Electric box opening is possible with the switch in "0" position only.</p>
	<p>096319 Always disconnect the power cord before opening the electric box.</p>
	<p>524993 Hand injury hazard</p>
	<p>S20097-US Motor rotate direction</p>

## SECTION 3 PC100 SETUP

### 3.1 Site Preparation



**DANGER!** Have a certified electrician install the power to your machine.



**WARNING!** Ensure the power supply cables are not a trip hazard.



**CAUTION!** Improper voltage will cause damage to the motors and electronic components.

**NOTICE** The power supply must meet the motor specifications concerning wire size, fused disconnect, and voltage, which are provided in the motor's manual.

The electrical installation must meet local codes.

Locate the PC100 in a dry work area on a firm, level surface.

Ensure proper lighting is available, with attention to extra lighting directly over the PC100.

Allow room for the longest piece of material to run through and exit the machine with ease of movement.

Allow space for storing and handling the material that will be sawed on your PC100.

Do not use in temperatures below freezing [32°F (0°C)].

Do not allow the power cables or dust collection hoses to become trip hazards. Plan the routes carefully.

Use a visual demarcation such as safety floor tape within the risk area.

### ONSITE SETUP



**WARNING!** Maintain a clean and clear path for all necessary movement around the machine and material stacking areas.

Keep all hoses, cables, or wire out of the walkway.

Do not allow children in the work area.

Set up machine on firm, level ground.

### 3.2 Uncrate and Prepare Parts

1. Check your PC100 as soon as it is received. Report any transport damage to Wood-Mizer and shipping agent immediately.
2. Set aside dust chutes, accessories, and other loose items.

3. Remove shipping straps/crating on flat, level surface.
4. Ensure machine includes all safety decals before installing [See Section 6.15](#).

### 3.3 Position PC100 for Installation

1. Lift machine using lifting eye and a hoist or forklift with proper lifting gear and procedures.

**NOTE:** Lifting straps/chains or carefully aligned forks can be used to lift the machine by the attached shipping fence. See FIG. 3-1

2. Position machine in desired location, leaving ample surrounding space.
3. Shim four corners of machine until leveled front-to-rear and side-to-side.
4. Anchor machine to flat level floor using 1/2" hardware (not included) in each of four footpads See FIG. 3-1.

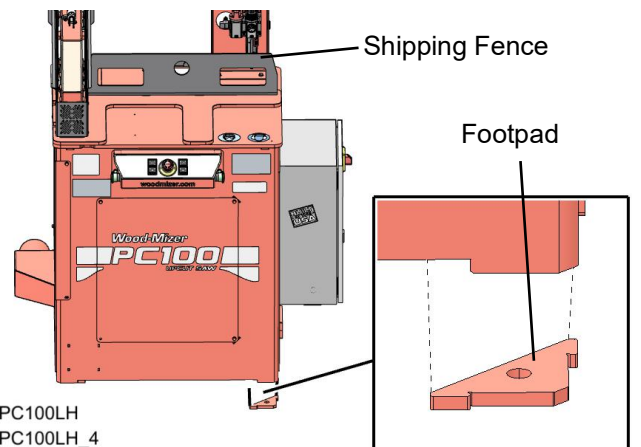

FIG. 3-1

### 3.4 Dust Collection

The PC100 has a dust collection hood with a 4" port--sized to fit flexible hose and a 12" waste chute.

A dust collection system rate approximately of 500 CFM minimum is recommended for use with the PC100.

When using a collection system, keep in mind:

- Check your local waste disposal codes before designing your dust collection system.
- Design access to your dust collection bins so that they can be easily emptied.
- Short hose runs and smooth-walled hoses reduce suction loss within the system.
- Locate the dust collector controls near the PC100 controls.
- Collection systems are loud; use ear protection.
- If you are operating this machine in a climate-controlled building and blowing the

### 3 PC100 Setup

#### Check Drive Belt Tension

dust outside, the vacuum created by the dust collector can quickly empty your building of its heated or cooled air.

- If blowing the dust to an indoor bin, an air filter will be necessary to prevent wood dust from reducing the air quality inside of your building.
  - If selling sawdust for use with livestock, do not use harsh chemicals for cleaning or lubricating machinery.
1. If cutting new lumber (in which machine will not encounter metal fasteners) connect supplied 4" dust collection hood and accompanying hardware.
  2. Connect port to building dust collection system.
  3. If cutting recycled lumber [See Section 4.7](#) for installation of optional lower chute bracket kit.

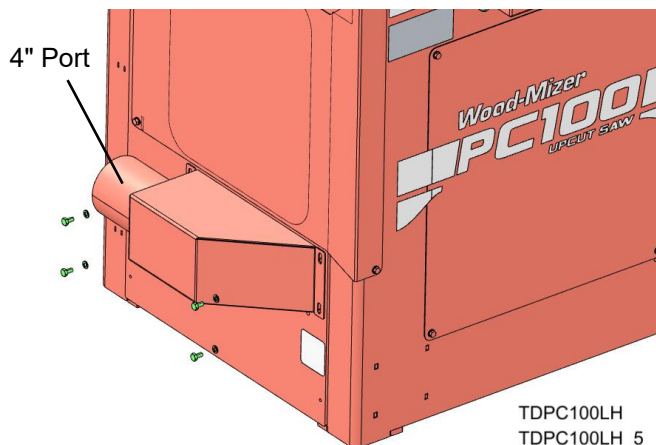

FIG. 3-2

#### 3.5 Check Drive Belt Tension

1. Remove side and front panels using 7/16" socket or wrench.
2. Check for obstructions in blade path and waste chute compartment.
3. Remove any cable ties securing pivot arbor assembly.
4. Reinstall side panel.
5. Use tension gauge to check tension of three drive belts.

**NOTE:** Tension requirements are printed on decal inside cabinet (3.6-5.1lbs@0.16in/16-23N @ 4mm)

6. Use motor adjustment slots to adjust tension.
7. Keep drive pulleys aligned.
  - Loosen four motor mounting bolts.
  - Turn two adjustment bolts.
  - Re-tighten mounting bolts..

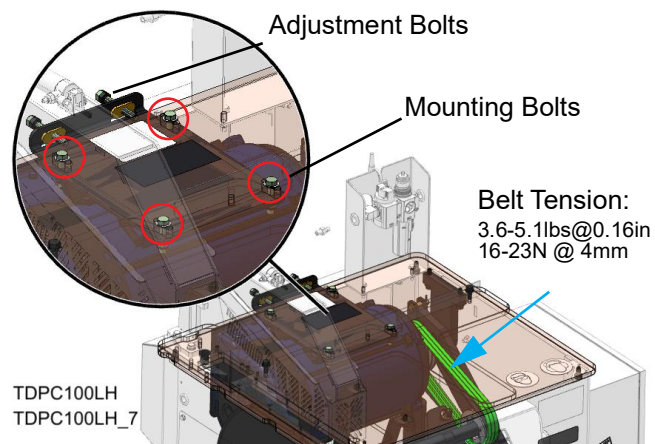

FIG. 3-3

#### 3.6 Initial Control Valve Adjustments

1. Adjust flow control valves on air cylinder clockwise until they are under half of their full operating capacity. These will be readjusted later.

**NOTES:** Clockwise restricts airflow. Counter-clockwise increases airflow.

Upper valve adjusts upward speed of blade during cutting action.

Lower valve adjusts downward speed of blade as it retracts below table.

2. Reinstall front panel.

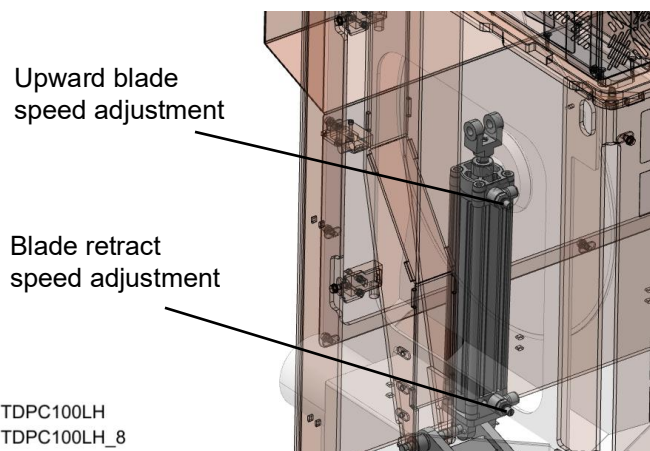

FIG. 3-4

#### 3.7 Electrical



**WARNING!** Installation must be performed by a certified electrician in accordance with all applicable local laws, rules and regulations.

All wire should have a minimum rating of 75C.

1. Connect power to the load side of Q1 on terminals L1, L2, and L3.

2. Connect ground to ground terminal on X0.

**NOTE:** L1 and L2 only for 1 Phase motor

**Table 1: PC100 Series Electrical**

Model	hp Rating	Voltage	Current	Recommended Fusing	SCCR w/Type J Fusing	Recommended Power Wiring	Recommended Min. Ground Wire
PC100EA	10	240V 1ph	40A	70A Type J	65kA	6AWG Wire 4AWG 3C cable	8AWG Wire
PC100EB	10	240V 3ph	28A	50A Type J	10kA	8AWG Wire 8AWG 3C cable	10AWG Wire
PC100EC	10	480V 3ph	13A	20A Type J	10kA	12AWG Wire 12AWG 3C cable	12AWG Wire

### 3.8 Reinstall Fence

1. Set height adjustment to maximum setting.
2. Loosely reinstall the fence.
3. Use a large square to align one side with gap cut in lower pad.
4. Align fence to perpendicular side of the square to ensure that it is perpendicular to cut.
5. Tighten three (3) bolts with a 1/2" socket or wrench to secure fence.

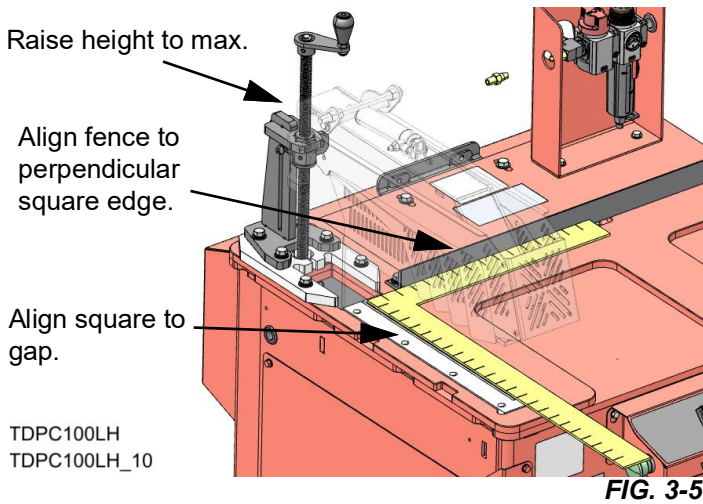

See Section SECTION 5 for operation instructions.

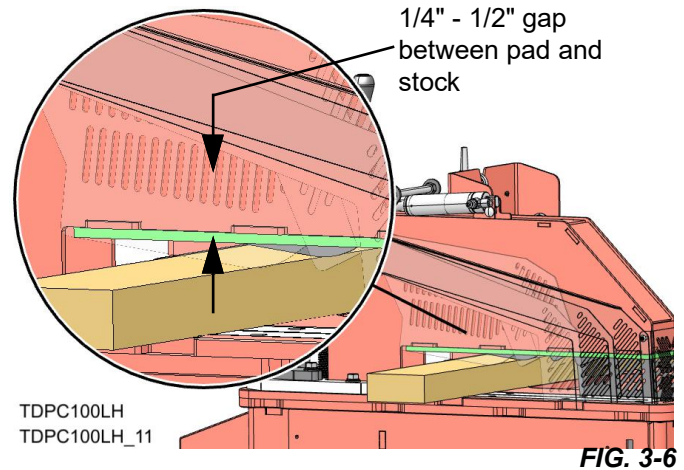

3. Gradually adjust flow control valves until blade extends and retracts at a desirable speed to produce a smooth, high quality cut. See FIG. 3-4
4. Use the checklist below to determine proper blade pivot speed.
  - Reduce blade travel speed if:
    - The machine experiences excessive load or noise during a cut or stalls the blade.
    - The chips produced are large or irregular and clog the blade gullets.
    - The cuts are wavy, scored, or irregular.
    - The blades dull prematurely due to high loading.
  - Increase blade travel speed if:
    - The cuts generate excessive heat or scorching on the material.
    - The blades dull prematurely due to heat build-up

### 3.9 Blade Travel Adjustments

1. Set height adjustment so upper pad is 1/4"-1/2" above desired stock when in raised position.
2. Cut material.



## SECTION 4 PC100 ACCESSORY SETUP

### 4.1 Overview

**All images depict left-hand machine configuration unless otherwise noted. In this configuration, material is fed from right to left from the operator's perspective.**

Check items as soon as it is received. Report any transport damage to Wood-Mizer and shipping agent immediately.

**NOTE:** Each table section is 4ft in length. Tables can be attached in series for extended support.

Understand proper orientation. From the operator's perspective:

- If using a left-handed machine (pictured):
  - Outfeed tables will be mounted to the left of the machine
  - Infeed tables will be mounted to the right.
- If using a right-handed machine:
  - Outfeed tables will be mounted to the right of the machine
  - Infeed tables will be mounted to the left.
- The rearward side of each table can be identified by the additional 3 square cutouts.

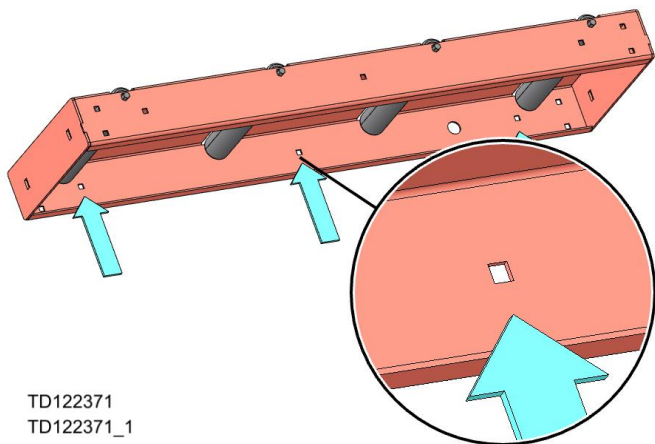

TD122371  
 TD122371\_1

**FIG. 4-1**

### 4.2 Assemble Legs and Brackets

1. Assemble legs to outermost end of each table section.  
 Use 3/8"x1 carriage bolts and 3/8" flanged locking nuts.
2. Mount leveling feet using 1/2" plain nuts.

**NOTE:** The innermost end will attach either to machine body or, in case of multiple infeed or out-feed tables, to an adjacent table.

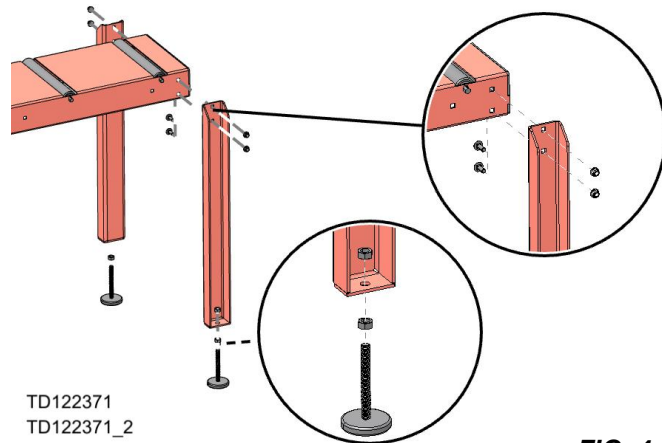

TD122371  
 TD122371\_2

**FIG. 4-2**

3. Loosely install adjustment brackets on innermost end of each table section.

Use 3/8"x1 carriage bolts and 3/8" flanged locking nuts.

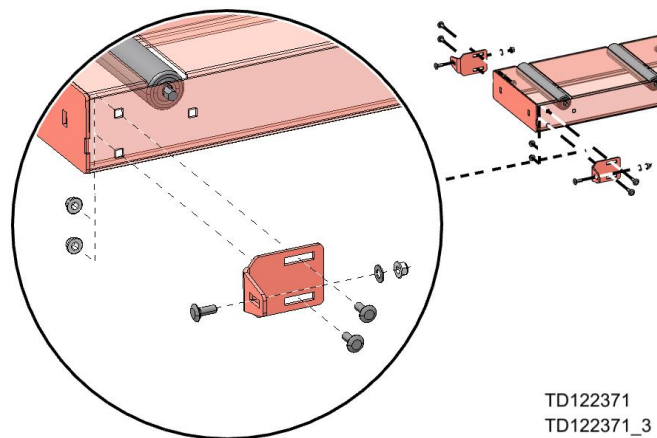

TD122371  
 TD122371\_3

**FIG. 4-3**

### 4.3 Install Tables

1. If installing outfeed table directly to PC100, locate the knockout in side of cabinet body

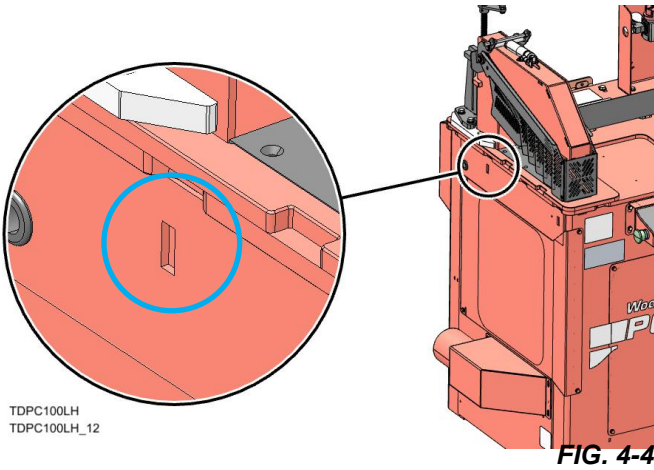

2. Raise blade guard to highest position.
3. Have a partner position two 3/8"x1 carriage bolts inside cabinet as shown in Figure 4-5.

**NOTE:** If alone, carriage bolts may be held in place with 3/8" retaining washers (not included).

4. Align table sections to mounting slots on machine and loosely secure with 3/8" flange locking nuts as shown in Figure 4-6.

#### INSIDE CABINET

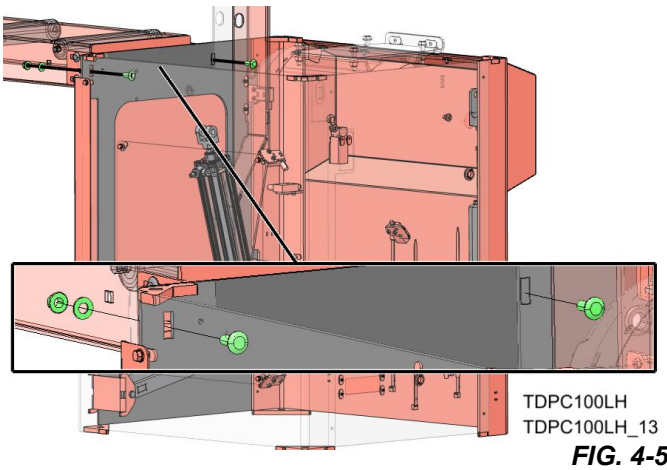

#### OUTSIDE CABINET

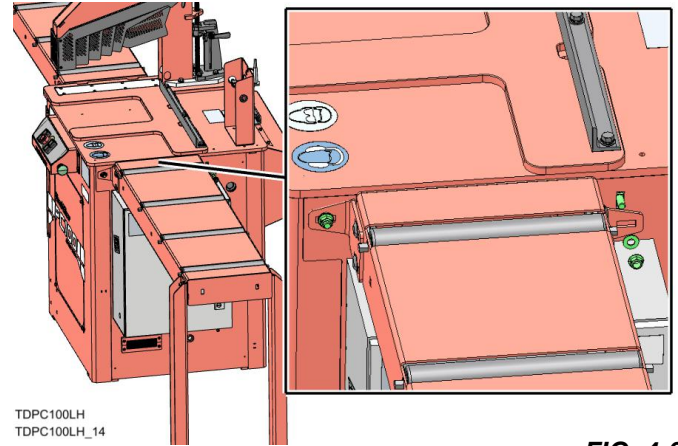

### 4.4 Install Table Supports

1. For outfeed tables, attach backer fence using (3) 3/8" carriage bolts and 3/8" flanged locking nuts.

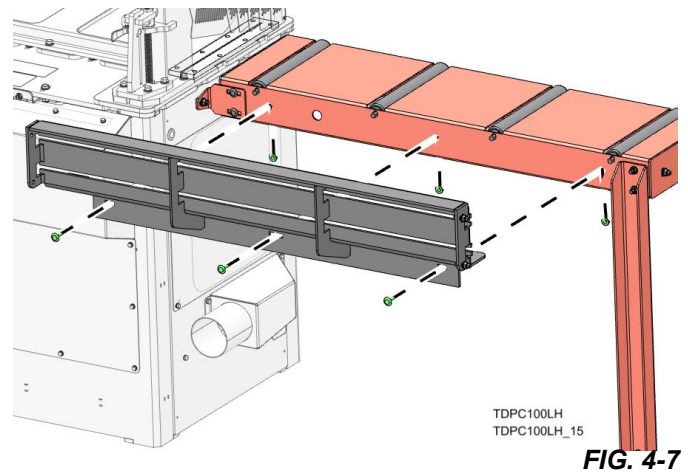

2. For infeed tables, attach backstop using three 3/8" carriage bolts and 3/8" flanged locking nuts.

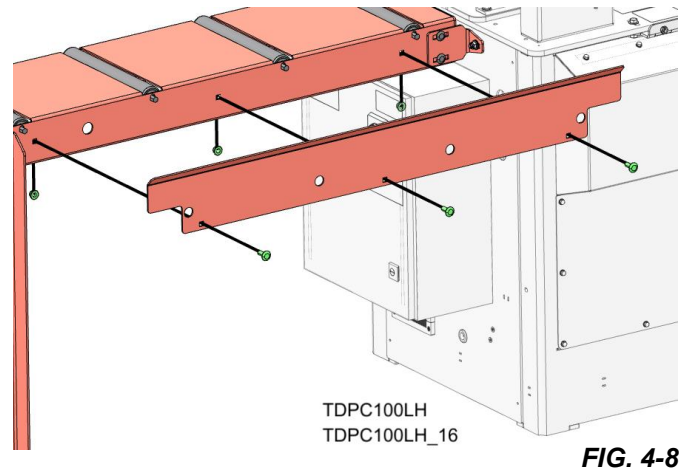

## 4 PC100 Accessory Setup

### Align and Level Tables

3. Install stringer stops backstop on scale weldment using 3/8x1 HH bolts, 3/8" serrated washers, and 3/8" flat washers.

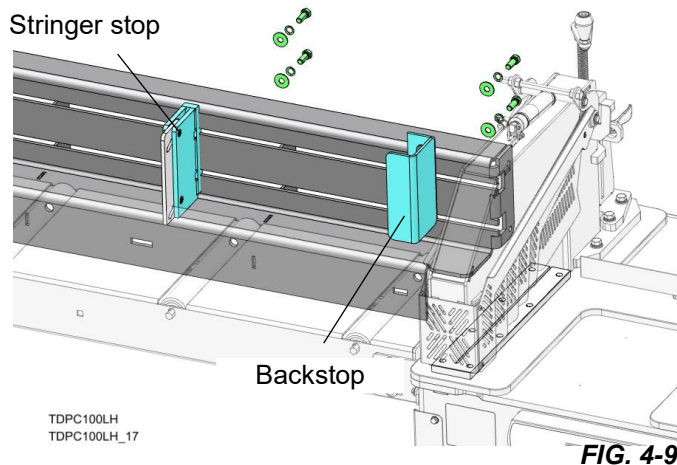

## 4.5 Align and Level Tables

1. Place a long straightedge on machine's tabletop.
2. Adjust tables vertically so rollers are flush and level with the straightedge.

Use leveling feet (See Figure 4-10) and vertical adjustment slots in machine (See Figure 4-12).

**Tip:** Lightly tighten hardware and do fine adjustments using a soft-faced mallet

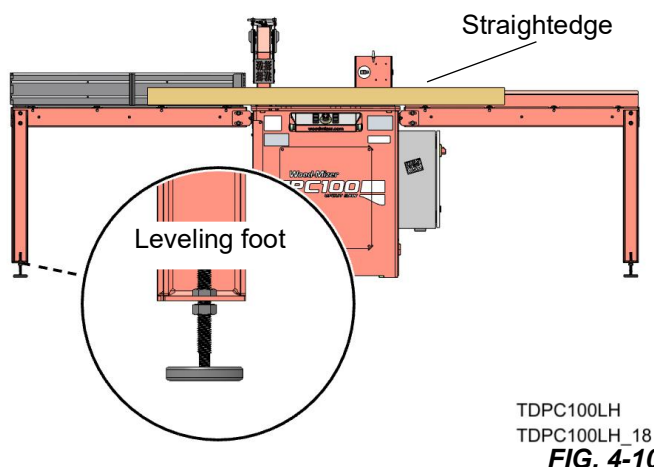

3. Align infeed and outfeed tables so that infeed backstop and outfeed boardstop mounts are just behind the straightedge.
  - Use front-to-back adjustment slots on adjustment brackets. See FIG. 4-12

**Tip:** Lightly tighten hardware and do fine adjustments using a soft-faced mallet.
4. Position tables with a 1" gap between the table end and the machine tabletop.
  - Use left to right adjustment slots on adjustment brackets. See FIG. 4-12

## TOP VIEW

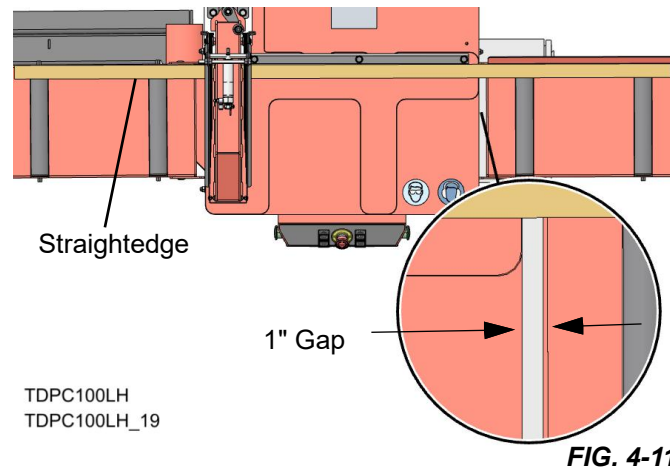

## TABLE ADJUSTMENT BRACKET

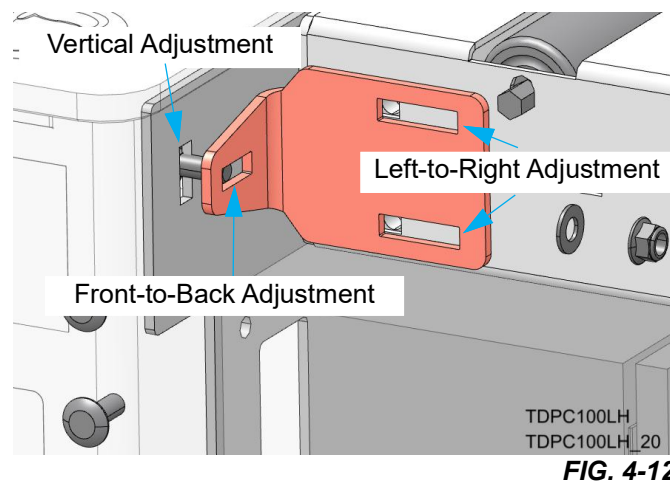

5. If installing multiple tables in series, align height of additional tables to previous table, and secure using 3/8"x1 carriage bolts and 3/8" flanged locking nuts.
6. After rechecking alignment from previous three steps, tighten all hardware on adjustment brackets and leveling feet.

## 4.6 Install Scale Decals

Each 4' outfeed table can be paired with a corresponding board measurement scale.

1. Center scale decal, on scale weldment.
2. Use sheet metal cutouts to align decal front-to-back and left-to-right.
3. Use left-to-right adjustment slots in scale weldment, position scale weldment such that a measurement from outermost edge of kerf in throat plate aligns to its correct marking on scale.
4. Repeat as needed for additional outfeed tables.



## 4.7 Optional Reclaimed Lumber Dust Chute

If cutting recycled lumber (in which machine will encounter metal fasteners) connect optional lower chute bracket kit for discharging into conveyor or collection hopper.

1. Remove (4) 1/4 x 1/2 HH bolts and (4) split lock washers.
2. Remove standard dust chute with 4" port.
3. Install chute bracket and reclaimed lumber chute using (4) 1/4 x 5/8 HH bolts and (4) split lock washers

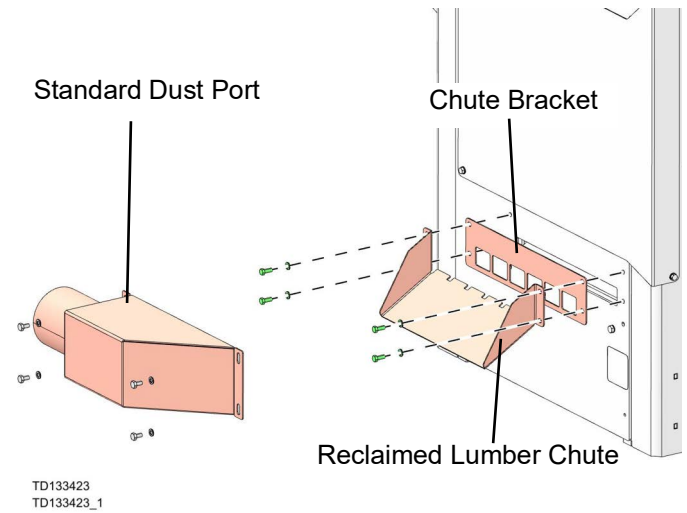

## SECTION 5 OPERATION

### 5.1 Operation

Read and understand all information and warnings contained in the **General Safety** section of this Operator's Manual before starting the PC100.

**WARNING!** Always operate the saw as designed to prevent injury.

**NOTE:** The PC100 is a 2-handed operation saw for the protection of the operator.

#### PRE-CUT ADJUSTMENTS

1. Verify air regulator is set at 90 psi.
2. Place stock on work table.
3. Adjust clamp guard until the upper clamp pad is 1/4" - 1/2" above the stock.

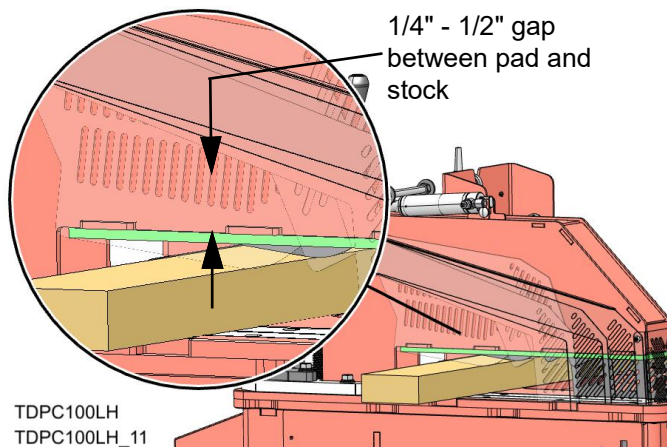

FIG. 5-1

4. If using outfeed table with end stop, slide end stop to desired length of cut and tighten with clamping handle.

#### STARTING THE PC100

**DANGER!** Do not operate the saw without all covers and guards in place.

**WARNING!** Clear the machine of any loose tools or other items before powering on.

Motor will not run if the all screws in access panels are not fully tightened, or if the Emergency Stop is depressed. If depressed, turn to the left and pull it to the correct position.

1. Press Main Power ON button.
2. Press Blade motor Power ON button.

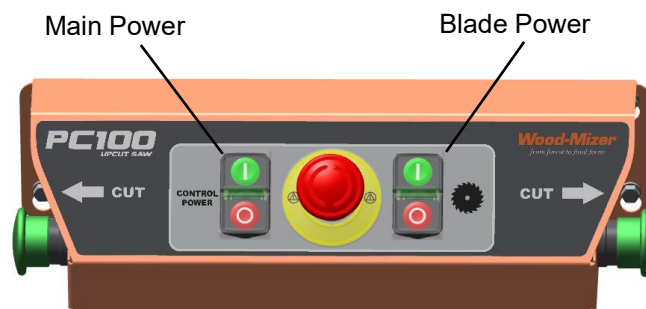

TD122370  
TD122370\_1

FIG. 5-2

3. If using powered dust collection system, power on system.

#### MAKE A CUT

1. Set stock against end stop, if installed.
2. Press stock against infeed backstop and fence on work table.
3. Fully press blade engagement buttons on left and right-hand side of operator control box.

Clamp shields lower and material is secured during cut.

Blade travels upward through stock.

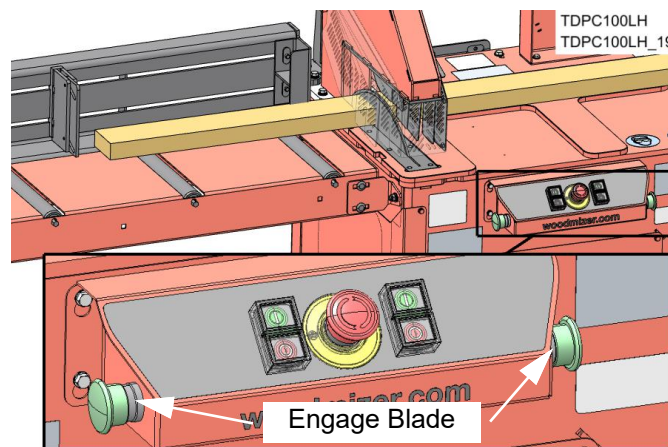

FIG. 5-3

4. Release blade engagement buttons.

Clamp releases and blade retracts below table.

#### STOPPING IN AN EMERGENCY

1. Press the Emergency Stop to stop the machine immediately.

Once this switch is pressed, the machine cannot be restarted until this switch is turned 90° and pulled out to reset.

## SECTION 6 MAINTENANCE

This section lists the maintenance procedures needed to ensure optimal machine performance and durability.

**! DANGER!** Disconnect and lock out power supply before performing any maintenance work, cleaning, or servicing the PC100. Failure to do so will result in death or serious injury.

### 6.1 Sawdust Removal

**! WARNING!** Clean sawdust from all guards, vents, control boxes, or any area where sawdust may gather **after every 8-hour shift**. Failure to do so may result in fire, causing death or serious injury.



1. Remove front and side access panels to clean.
2. Use compressed air to clean dust and debris from cabinet, blade compartment, and dust chute daily.
3. Fully tighten all fasteners when reinstalling panels.

**NOTE:** Safety mechanisms will not allow the machine to run if the panels are not completely secured.

### 6.2 Blade Inspection

1. Check blades weekly for sharpness.
2. Check for cracks and missing carbides before each use.

**! WARNING!** Using a broken or dull blade may cause injury or equipment damage.

3. If cutting new lumber, change or sharpen approximately every 90 days.

**NOTE:** Time will vary based on usage and wood species.

If cutting recycled material, blades will dull more quickly depending on prevalence of fasteners.

**NOTICE** Dull blade use places excessive strain on machine components, creates erratic, unpredictable cutting action, and generates excessive heat while cutting.

### 6.3 Blade Replacement

**! WARNING!** Before changing the blade on this machine, lockout the electrical supply to the machine.

Wear gloves when working with the blade.

4. Remove side and front panels using 7/16" socket or wrench.
5. Use 1" open-ended wrench to brace arbor shaft.
6. Loosen arbor nut using a 1-1/2" socket and remove outer blade collar.

**NOTE:** Arbor nut loosens in same direction as blade cutting rotation.

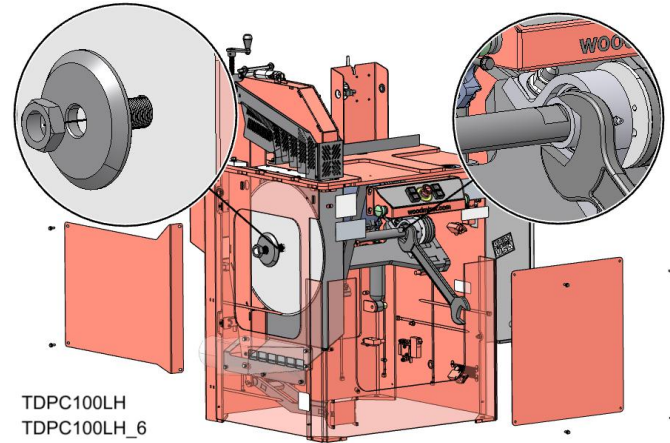

TDPC100LH  
TDPC100LH\_6

FIG. 6-1

**NOTE:** RH machines have a LH threaded arbor nut.

7. Slide existing blade off of blade arbor shaft.
8. Install 18" blade according to blade direction decal using blade pass-through slot as shown in Figure 6-2.

**NOTE:** Blade must have 1" arbor hole.

Blades sold separately. (WM offers 60-tooth, 80-tooth, and 120-tooth options.)

9. With 1" wrench bracing arbor shaft, tighten arbor nut to 150 +/- 10 ft-lbs using 1-1/2" socket.

**! CAUTION!** Over-tightening the arbor nut can damage the blade collar.

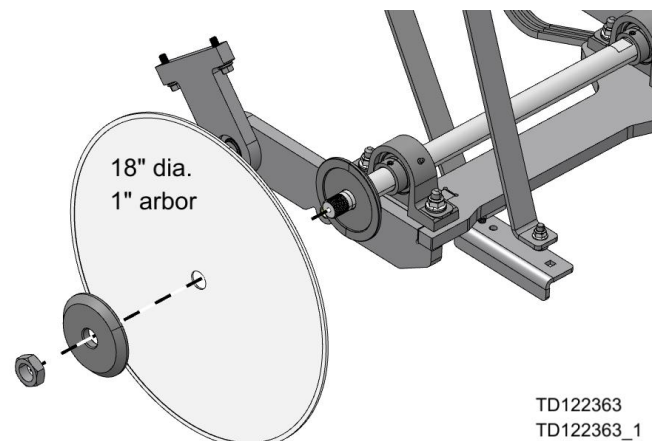

TD122363  
TD122363\_1

FIG. 6-2

## 6.4 Belt Inspection

1. Check belts for wear and excessive stretching every 90 days.

**NOTE:** Belt tension specification: 3.6-5.1lbs@0.16 / 16-23 N @ 4mm

[See Section 3.5](#) for adjustment instructions.

2. Replace belts every 12 months.

**NOTE:** Worn belts can lead to poor machine performance.

## 6.5 Drain Water Separator

Drain water from the air filter/regulator unit weekly by turning stopcock to “open” position momentarily. Figure 6-1 shows stopcock in “closed” position.

**NOTE:** Water in air lines can cause performance issues and shorten machine life span.

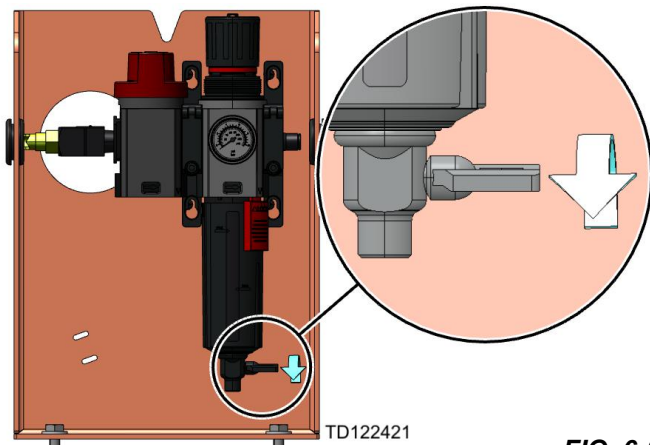

**FIG. 6-3**

## 6.6 Lubrication

1. Lubricate arbor bearings every 2-4 weeks.
2. Apply Lithium-based NLGI #2 grease through 2 integrated grease ports.

**NOTE:** Bearings are factory prelubricated and **do not** require supplemental grease before service life begins. Over-lubrication is a major cause of bear-

ing failures. Relubricate according to the recommended schedule.

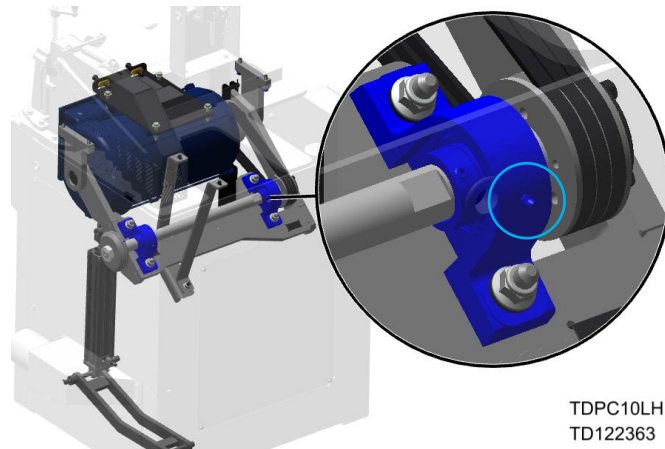

TDPC10LH  
TD122363

**FIG. 6-4**

## 6.7 Replace Clamp Pads

Periodically, upper and lower clamp pads will wear and to be replaced.



**WARNING!** Before changing the clamp pads on this machine, lockout the electrical supply to the machine.

1. Raise clamp assembly to maximum height.
2. Remove (8) screws from top pad and (8) screws from lower pad.
3. Install new pads. See FIG. 6-5
4. Verify the air pressure regulator is set at 90 psi.
5. Verify all guards are in place.
6. Power on machine and energize blade according to operation instructions and safety warnings included in this manual.

[See Section SECTION 5](#) for operation instructions.

7. With no stock loaded, use dual operator buttons so blade cuts a kerf in upper and lower plastic clamp pads.
8. Turn off blade motor and machine power.

**NOTE:** Do not disconnect air supply. This will keep the blade guard in raised position.

Upper clamp pad

Lower clamp pad

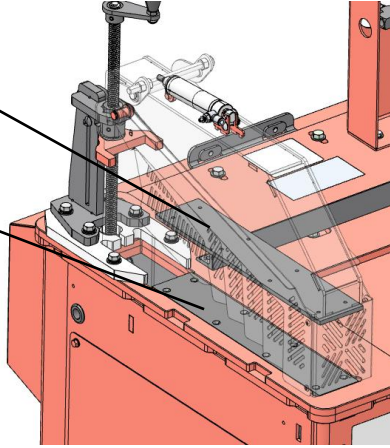

TDPC100LH  
TDPC100LH\_9

**FIG. 6-5**

## SECTION 7 PARTS

### 7.1 How To Use The Parts List

- Use the table of contents to locate the assembly that contains the part you need.
- Go to the appropriate section and locate the part in the illustration.
- Use the number pointing to the part to locate the correct part number and description in the table.
- Parts shown indented under another part are included with that part.

#### *To Order Parts*

- From the continental US, call **1-800-525-8100** to order parts. Have your customer number, vehicle identification number, and part numbers ready when you call.
- From other international locations, contact the Wood-Mizer distributor in your area for parts.

### 7.2 Sample Assembly

REF	PART #	DESCRIPTION	COMMENTS	QTY.
	012345	SAMPLE ASSEMBLY, COMPLETE	INCLUDES ITEMS 1-6	1
1	F02222-22	Sample Part		1
2	F03333-33	Sample Part		2
	098765	Sample Subassembly	Includes items 3-6	1
3	S04444-44	Subassembly Sample Part		1
4	K55555	Subassembly Sample Part		1
	054321	Sample Sub-Subassembly	Includes items 5-6	2
5	022222	Sub-Subassembly Sample Part		1
6	F10234-56	Sub-Subassembly Sample Part		1

The Sample Assembly, Complete, part number 02345 (top level assembly) includes two parts (F0222-22 and F0333-33) and the 098765 subassembly.

Subassembly 098765 contains two parts(S04444-44 and K55555) and two copies of sub-subassembly 054321.

Each sub-subassembly 054321 contains two parts (022222 and F10234-56).



### 8.3 Overview

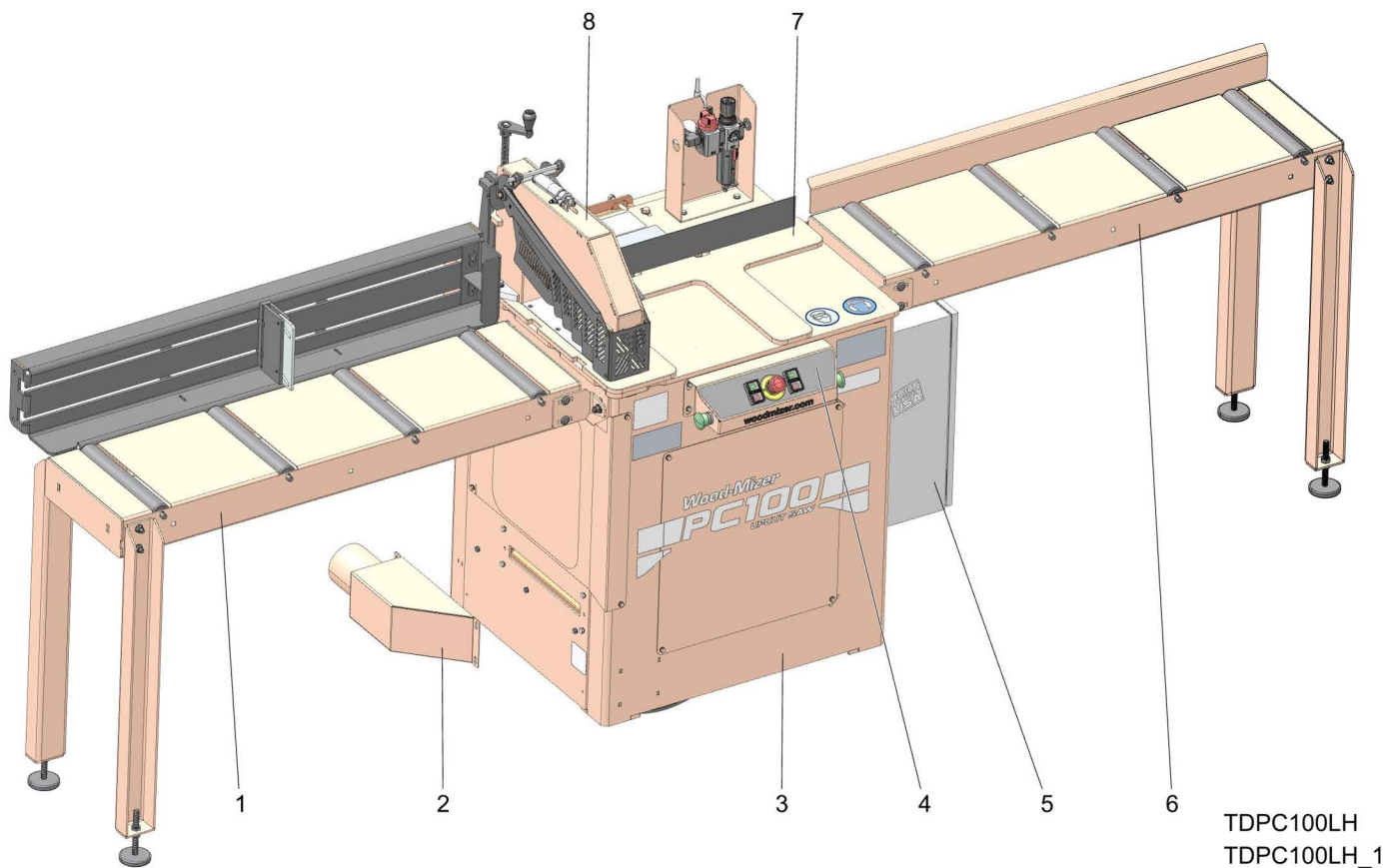

TDPC100LH  
TDPC100LH\_1

REF	PART #	DESCRIPTION	COMMENTS	QTY.
	PC100EA10-LH	SAW, UPCUT, 240V 1PH 10HP 18" BL, LH		1
	PC100EB10-LH	SAW, UPCUT, 240V 3PH 10HP 18" BL, LH		1
	PC100EC10-LH	SAW, UPCUT, 480V 3PH 10HP 18" BL, LH		1
	PC100EA10-RH	SAW, UPCUT, 240V 1PH 10HP 18" BL, RH		1
	PC100EB10-RH	SAW, UPCUT, 240V 3PH 10HP 18" BL, RH		1
	PC100EC10-RH	SAW, UPCUT, 480V 3PH 10HP 18" BL, RH		1
1	122372	Assy, Outfeed Table	Optional <a href="#">(See Section 8.20)</a>	1
2		Dust Chute Components	<a href="#">(See Section 8.5)</a>	1
3		Assembly, Cabinet	<a href="#">(See Section 8.4)</a>	1
		Inside Cabinet	<a href="#">(See Section 8.6)</a>	
4	122370	Operator Assembly, PC100	<a href="#">(See Section 8.16)</a>	1
5		Assembly, Elec. Box, PC100	<a href="#">(See Section 8.17)</a>	1
6	122371	Assembly, Infeed Table	Optional <a href="#">(See Section 8.19)</a>	1
7		Assembly, Table Top	<a href="#">(See Section 8.12)</a>	1
8	122369	Assembly, Clamp-Guard	<a href="#">(See Section 8.15)</a>	1
	122368	Kit, PC100 Decals	<a href="#">(See Section 8.18)</a>	1

## 8.4 Cabinet Assembly

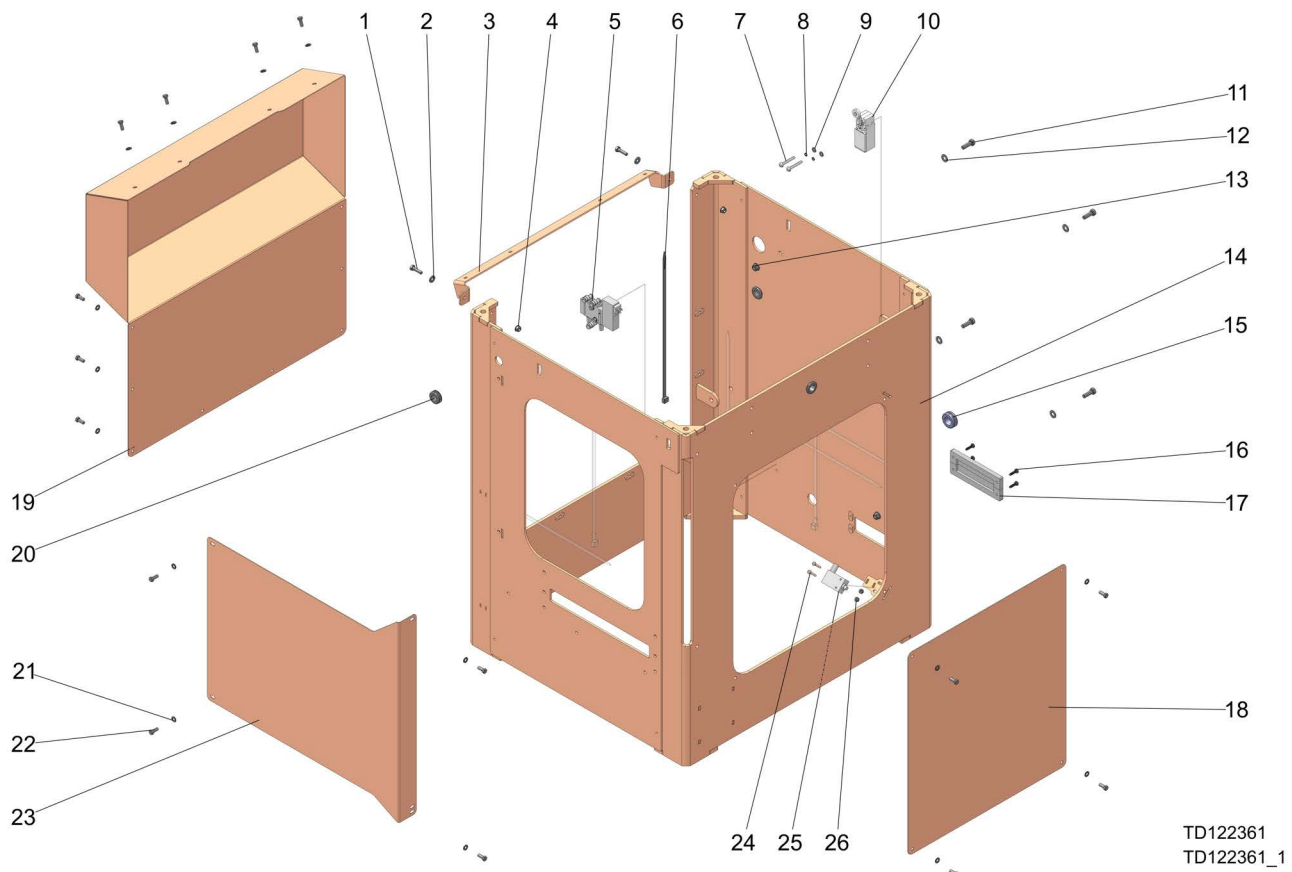

REF	PART #	DESCRIPTION	COMMENTS	QTY.
	122361	<b>CABINET ASSEMBLY - LH</b>		1
	122381	<b>CABINET ASSEMBLY - RH</b>	Right hand configuration not shown	1
1	F05005-101	Bolt, 1/4-20 X 1 Hex Head Gr5		2
2	F05011-11	Washer, 1/4 SAE Flat		2
3	122398	Weldment, Rear Cover Support		1
4	F05010-220	Nut, 1/4-20 Flanged Hex Nylock		2
5	122400	Assembly, Valve		1
	122559	Assy, Valve RH		1
6	F05089-5	Wire Tie, 14 In. Black		9
7	F05004-71	Bolt, #8-32x1 1/2 SI Round Head		1
8	F05011-84	Washer, #8 Split Lock		2
9	F05011-41	WASHER, #8 SAE FLAT ZINC		2
10	116567	Switch, XCKN2118G11 Limit		1
11	F05006-27	Bolt, 5/16-18 x 1 Gr 5 HH		4
12	F05011-17	Washer, 5/16 SAE Flat		4
13	F05010-221	Nut, 5/16-18 Flanged Hex Nylock		4
14	122389	Weldment, Cabinet		1
	122555	Wldmnt, Cabinet RH		1
15	025247	Grommet, Rubber 3/4 ID		1



REF	PART #	DESCRIPTION	COMMENTS	QTY.
16	F05015-42	Screw, #10-24x3/4 Ph Pan Hd, Type 23		4
17	068656	Brush Plate, 36x112mm Cable		1
18	122403	Plate, Access Panel		1
19	122402	Bracket, Rear Guard		1
20	033475	Grommet, 5/8 ID 3/16 GW Rubber		3
21	F05011-14	Washer, 1/4 Split Lock		20
22	F05005-137	Bolt, 1/4-20x5/8 HH GR5		20
23	122401	Bracket, Access Panel LH		1
	122558	Bracket, Access Panel RH		1
24	F05004-34	Screw, #8-32x1 S1 PH Machine Brass		1
25	121014	Safety Limit Switch, 1NO 1NC Plunger		7
26	F05010-41	Nut, #8-32 Self Locking		14

## 8.5 Dust Chute Components

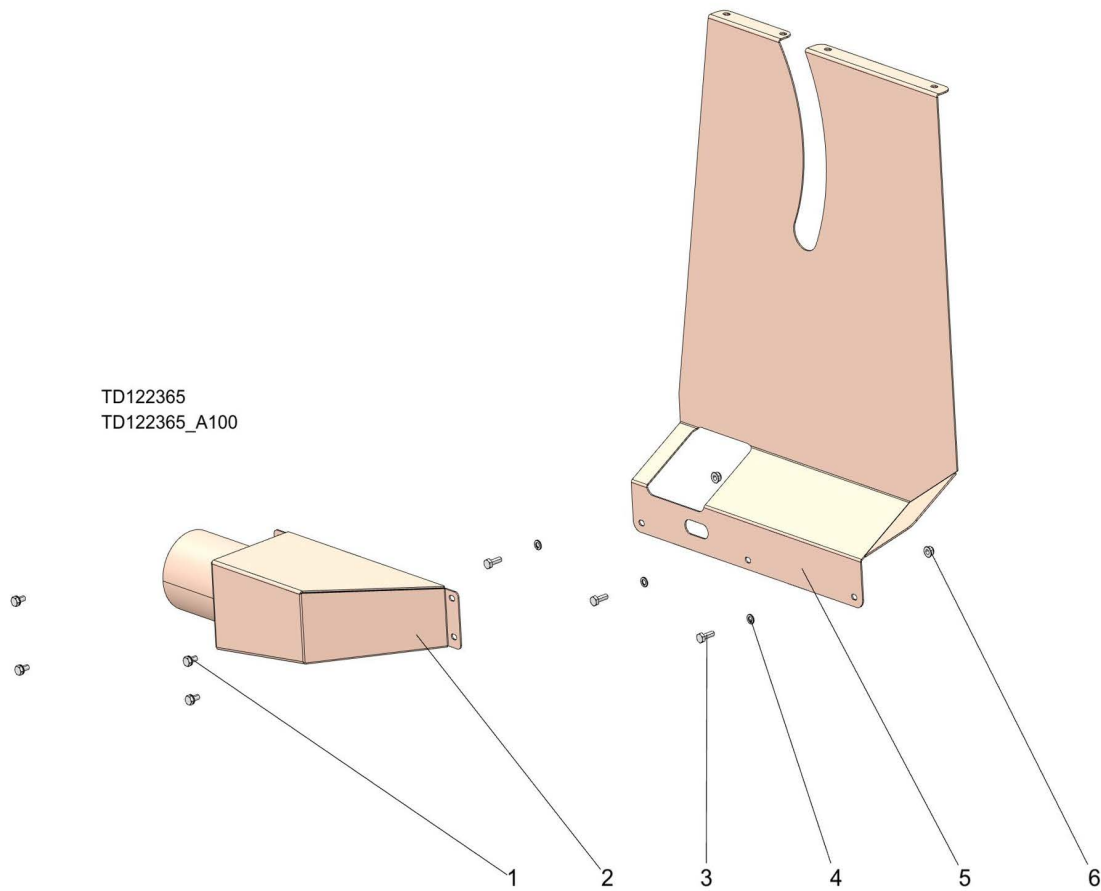

REF	PART #	DESCRIPTION	COMMENTS	QTY.
1	F05005-15	Bolt, 1/4-20x1/2 HH		4
2	122543	Wldmnt, Dust Chute LH		1
3	F05005-123	Bolt, 1/4-20x3/4 HH Gr5		3
4	F05011-14	Washer, 1/4 Split Lock		7
5	122450	Bracket, Blade Compartment LH		1
	122565	Bracket, Blade Compartment RH	Right hand configuration not shown	1
6	F05010-220	Nut, 1/4-20 Flanged Hex Nylock		3

### 8.6 Inside Cabinet

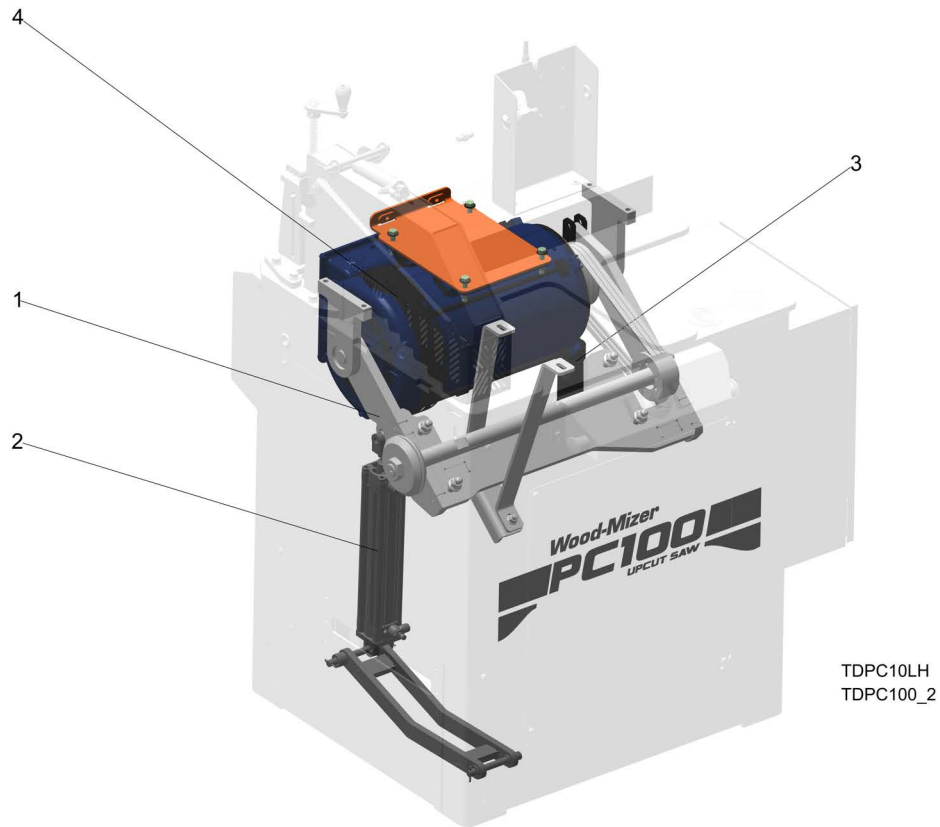

REF	PART #	DESCRIPTION	COMMENTS	QTY.
1	122363	Assy, Pivot LH ( <a href="#">See Section 8.7</a> )		1
2	122366	Assy, Cylinder LH ( <a href="#">See Section 8.8</a> )		1
3	122367	Assy, Shock Absorber LH ( <a href="#">See Section 8.9</a> )		1
4		Assy, Motor 10hp 3ph, 230/460v ( <a href="#">See Section 8.10</a> )	PC100EB10 and PC100EC10	1
		Assy, Motor 10hp 1ph, 230v ( <a href="#">See Section 8.11</a> )	PC100EA10	1
	122324	Blade, 18"x60T, Circular, Carbide Tip		1
	122325	Blade, 18"x80T, Circular, Carbide Tip	Option Purchased Separately	1
	122326	Blade, 18"x120T, Circular, Carbide Tip	Option Purchased Separately	1

## 8.7 Pivot Assembly

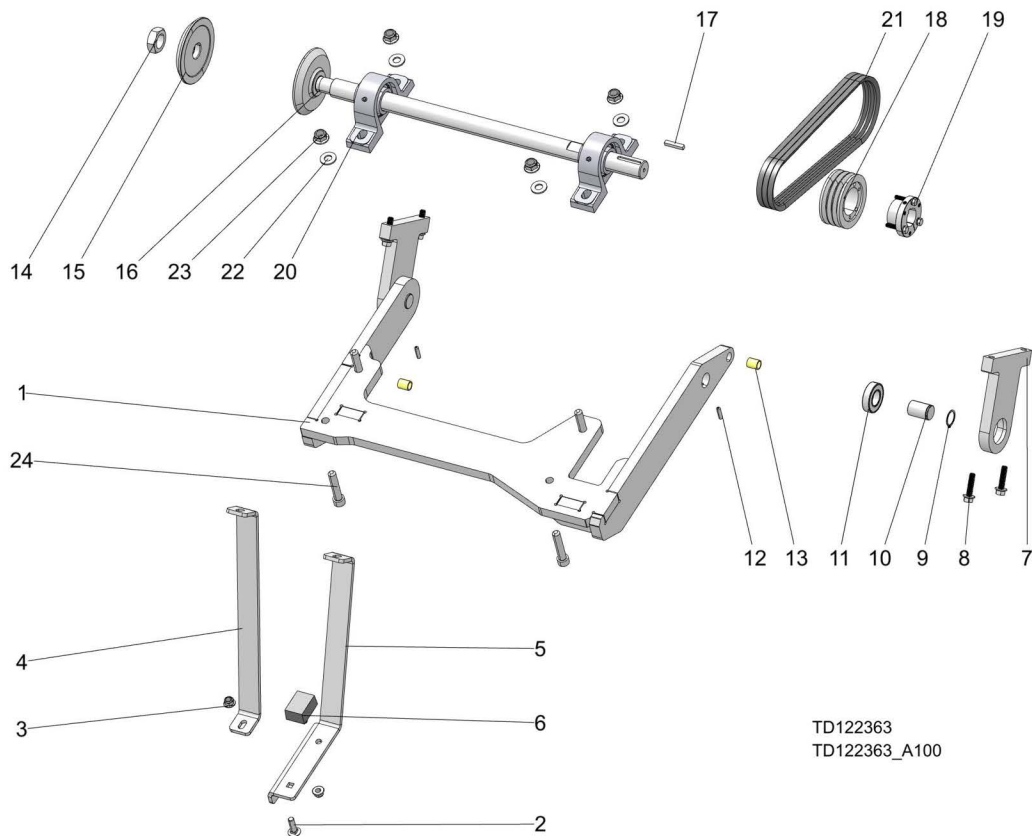

REF	PART #	DESCRIPTION	COMMENTS	QTY.
	122363	<b>PIVOT ASSEMBLY - LH</b>		1
	122383	<b>PIVOT ASSEMBLY - RH</b>	Right hand configuration not shown.	1
<b>1</b>	122425	Wldmnt, Pivot Arm LH		1
	122449	Wldmnt, Pivot Arm RH	Right hand configuration not shown.	1
	122433	Assy, Pivot Stop		1
<b>2</b>	F05007-11	Bolt, 3/8-16x1 1/4 Carriage		1
<b>3</b>	F05010-222	Nut, 3/8-16 Flanged Hex Nylock		2
<b>4</b>	122435	Bracket, Pivot Stop		1
<b>5</b>	122434	Bracket, Pivot Stop		1
<b>6</b>	106113	Bumper, Rectangular - 3/8-16 x 1 Stud		1
<b>7</b>	122424	Plate, Pivot Mount		2
<b>8</b>	F05007-272	Bolt, 3/8-16x1 1/2 FT HH Flange Gr5		4
<b>9</b>	F04254-15	Ring, 1 OR 3100-100 Retaining		2
<b>10</b>	122436	Shaft, Pivot		2
<b>11</b>	042360	Bearing, R16 Sealed		2
<b>12</b>	F05005-55	Screw, 1/4-20x1/2 SH Set Cup Pt Nyl		2
<b>13</b>	046976	Bushing, Bronze 1/2IDx5/8ODx3/4 L		2
	122430	Assy, 18" Circular Saw Arbor LH		1

REF	PART #	DESCRIPTION	COMMENTS	QTY.
	122564	Assy, 18" Circular Saw Arbor RH	Right hand configuration not shown.	1
<b>14</b>	F05010-118	Nut, 1-14 Hex Jam Zinc		1
	F05010-172	Nut, 1-14 Hex LH Thread Jam Zinc	Right hand configuration not shown.	1
<b>15</b>	122432	Collar, Blade		1
<b>16</b>	122379	Assy, Blade Arbor, RH Thread		1
	122563	Assy, Blade Arbor, LH Thread	Right hand configuration not shown.	1
<b>17</b>	017832	Key, 1/4Sq x 1 3/8		1
<b>18</b>	119083	Sheave, 3/3Vx365 SH		1
<b>19</b>	119082	Bushing, SH 1-1/4	Available in assemblies only.	1
<b>20</b>	122566	Bearing, 1-1/4" Pillow Block NAP206-20		2
<b>21</b>	122437	Belt, 3VX335		3
<b>22</b>	F05011-2	Washer, 1/2 SAE Flat		4
<b>23</b>	F05010-223	Nut, 1/2-13 Flanged Hex Nylock		4
<b>24</b>	F05008-39	Bolt, 1/2-13x2 1/2 SH BO		4

## 8.8 Cylinder Assembly

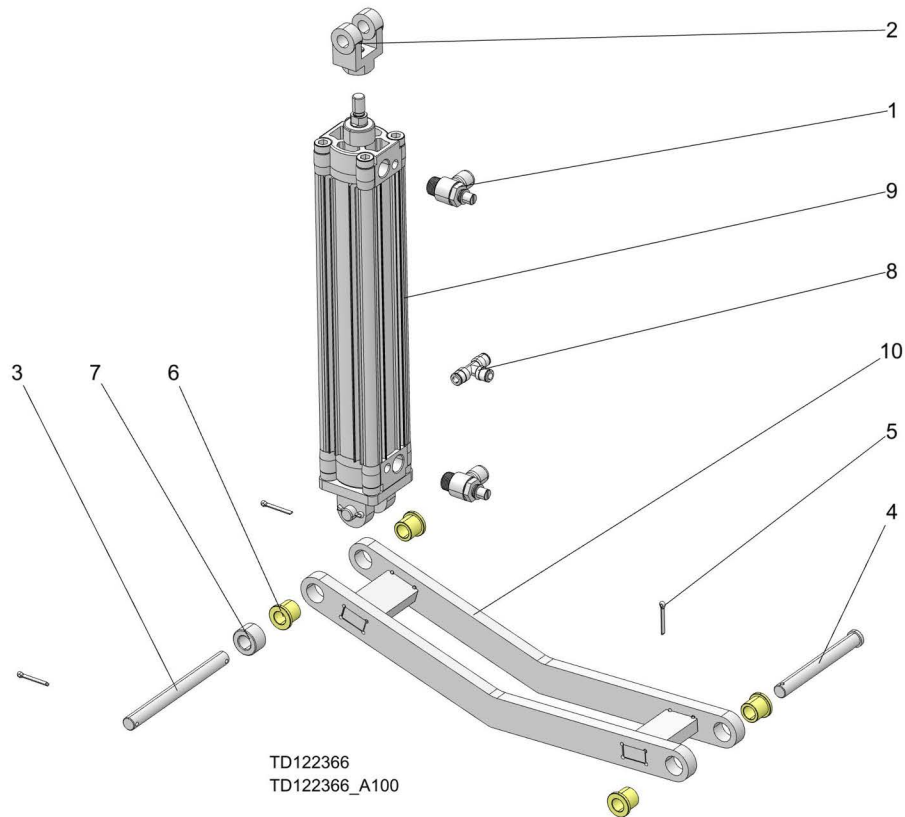

REF	PART #	DESCRIPTION	COMMENTS	QTY.
	122366	<b>CYLINDER ASSEMBLY - LH</b>		1
	122386	<b>CYLINDER ASSEMBLY - RH</b>	Right hand configuration not shown.	1
1	122490	Valve, 3/8NPT x 1/4Tube, Flow Ctrl		2
2	122491	Clevis, 7/16-20x1-1/2		1
3	122492	Pin, 1/2 x 5-7/32, Headless		1
4	F05012-171	Pin, 1/2x4-1/2 Clevis, Zinc		1
5	F05012-1	Pin, 1/8x1 Cotter		3
6	P22317	BUSHING, 1/2 X 3/4 BRONZED FLANGED		4
7	072015	Spacer, 1 ODX .53 IDx 5/8 Long		1
8	P21544	Fitting, 1/4 In Air Tee		1
9	122486	Cylinder, 2 Bore x 10 Stroke, Air		1
10	122487	Wldmnt, Linkage		1

## 8.9 Shock Absorber Assembly

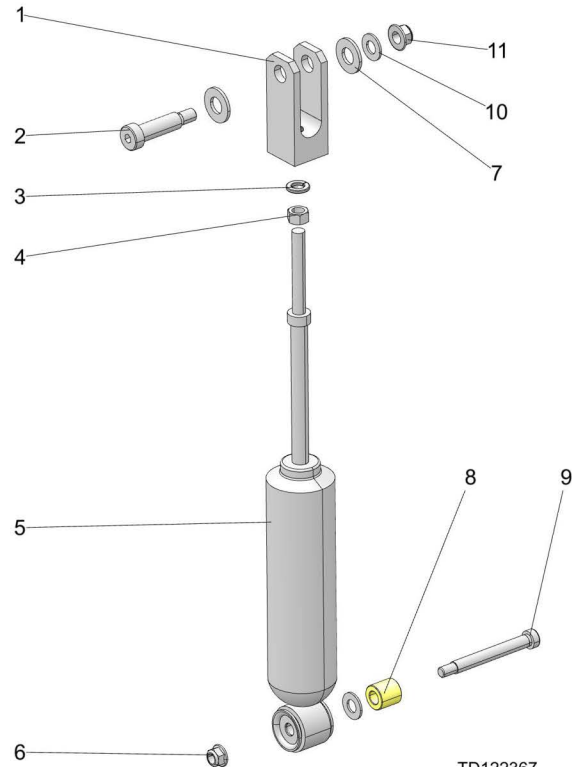

TD122367  
TD122367\_A100

REF	PART #	DESCRIPTION	COMMENTS	QTY.
	122367	<b>ASSEMBLY, SHOCK ABSORBER</b>		1
1	122494	Rod End, 3/8-16 Clevis		1
2	F05008-36	Bolt, 3/8-16x2-1/8 Socket Shoulder		1
3	F05011-4	Washer, 3/8 Split Lock		1
4	F05010-1	Nut, 3/8-16 Hex		1
5	P20263	Shock, Feed Roller		1
6	F05010-221	Nut, 5/16-18 Flanged Hex Nylock		1
7	F05011-2	Washer, 1/2 SAE Flat		2
8	T215	Spacer, 3/4 OD x 25/64 ID x 3/4 Lng		1
9	F05007-202	Bolt, 3/8x2 1/2 Soc Hd Shoulder		1
10	F05011-3	Washer, 3/8 Flat SAE		2
11	F05010-222	Nut, 3/8-16 Flanged Hex Nylock		1

### 8.10 3 Phase Motor Assembly

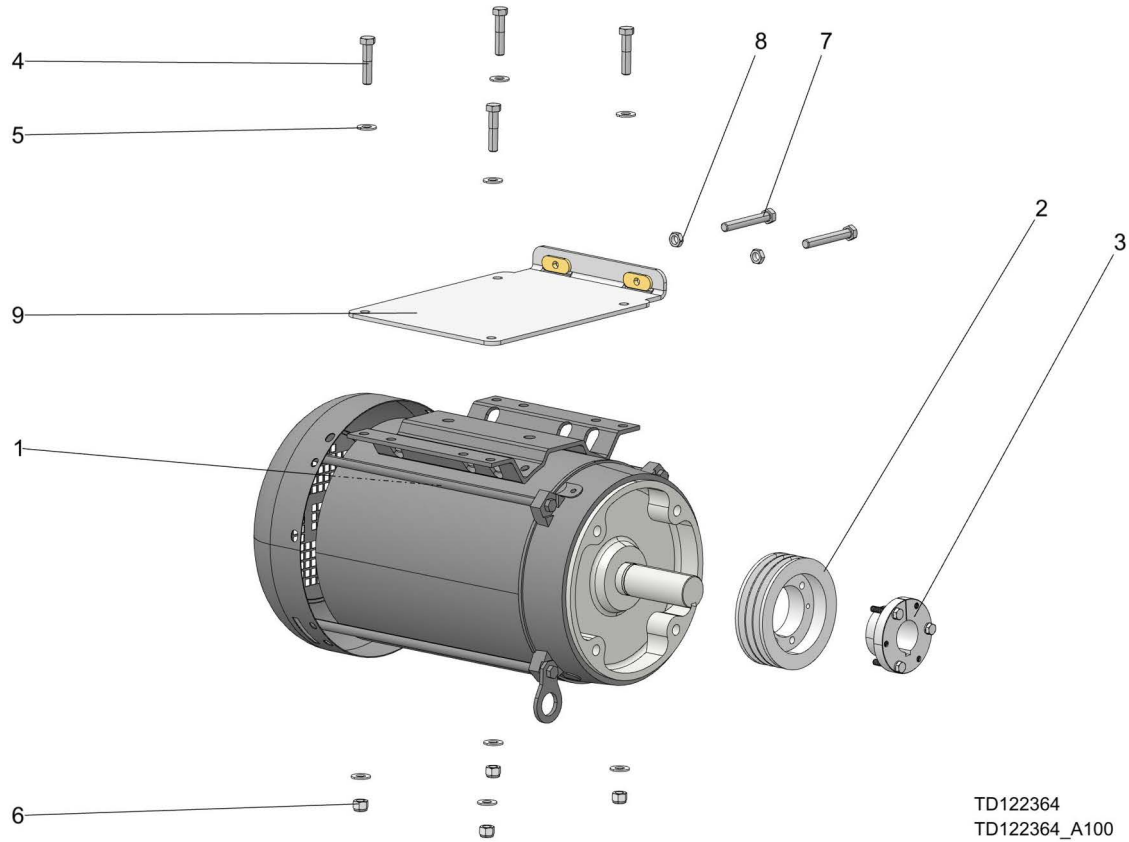

TD122364  
TD122364\_A100

REF	PART #	DESCRIPTION	COMMENTS	QTY.
<b>Used with PC100EB10 and PC100EC10</b>				
	122364	<b>ASSY, MOTOR LH 10HP 3PH, 230/460V</b>		1
	122384	<b>ASSY, MOTOR RH 10HP 3PH, 230/460V</b>	Right hand configuration not shown.	1
<b>1</b>	130076	Motor, 10HP 1800RPM Marathon Premium Eff		1
<b>2</b>	119077	Sheave, 3/3Vx475 SDS		1
<b>3</b>	119076	Bushing, SDS 1-3/8	Available in assemblies only.	1
<b>4</b>	F05007-119	Bolt, 3/8-16x1 3/4 HH Gr5		4
<b>5</b>	F05011-3	Washer, 3/8 Flat SAE		8
<b>6</b>	F05010-10	Nut, 3/8-16 Hex Nyl Lock		4
<b>7</b>	F05007-157	Bolt, 3/8-16x2 1/2 FT HHC Gr2		2
<b>8</b>	F05010-29	Nut, 3/8-16 Jam		2
<b>9</b>	122438	Weldmnt, Motor Adj.		1



### 8.11 1 Phase Motor Assembly

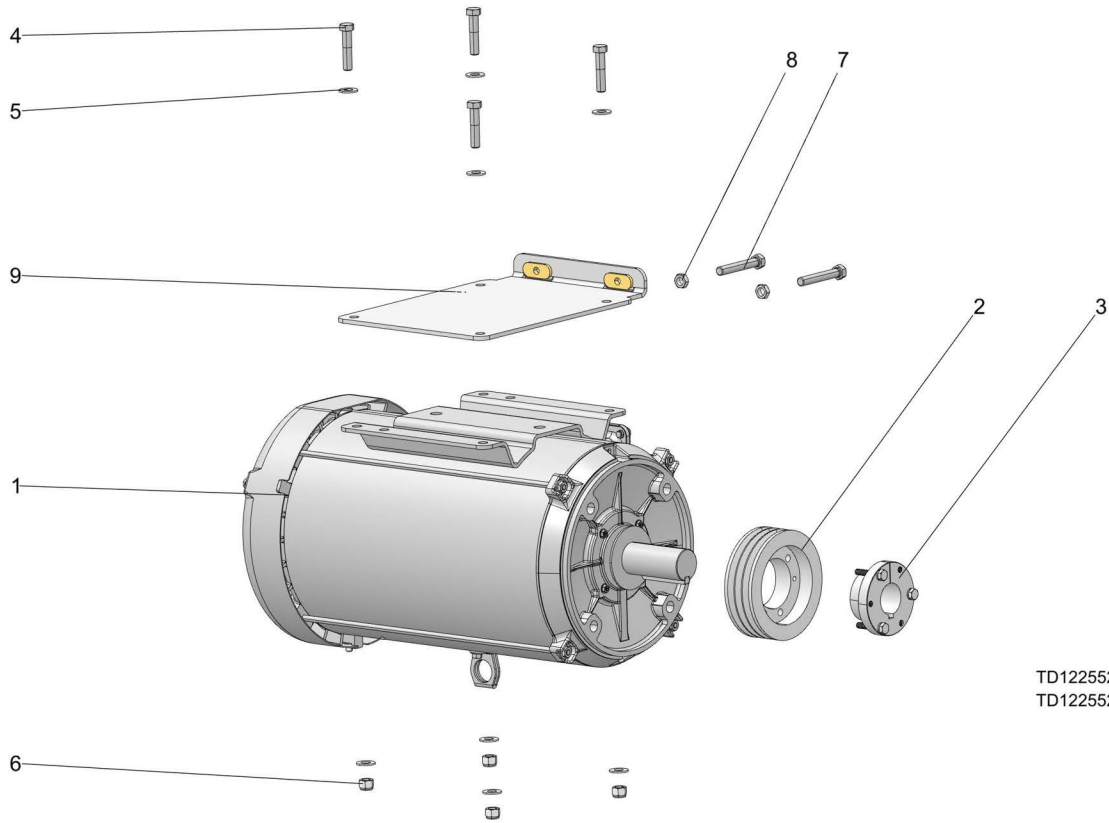

TD122552  
TD122552\_A100

REF	PART #	DESCRIPTION	COMMENTS	QTY.
<b>Used with PC100EA10</b>				
	122552	<b>ASSY, MOTOR LH 10HP 1PH, 230V</b>		1
	122554	<b>ASSY, MOTOR RH 10HP 1PH, 230V</b>	Right hand configuration not shown.	1
<b>1</b>	079949	Motor, 10HP 230V 1Ph 60Hz 1740RPM		1
<b>2</b>	119077	Sheave, 3/3Vx475 SDS		1
<b>3</b>	119076	Bushing, SDS 1-3/8	Available in assemblies only.	1
<b>4</b>	F05007-119	Bolt, 3/8-16x1 3/4 HH Gr5		4
<b>5</b>	F05011-3	Washer, 3/8 Flat SAE		8
<b>6</b>	F05010-10	Nut, 3/8-16 Hex Nyl Lock		4
<b>7</b>	F05007-157	Bolt, 3/8-16x2 1/2 FT HHC Gr2		2
<b>8</b>	F05010-29	Nut, 3/8-16 Jam		2
<b>9</b>	122438	Wldmnt, Motor Adj.		1

## 8.12 Table Top Assembly

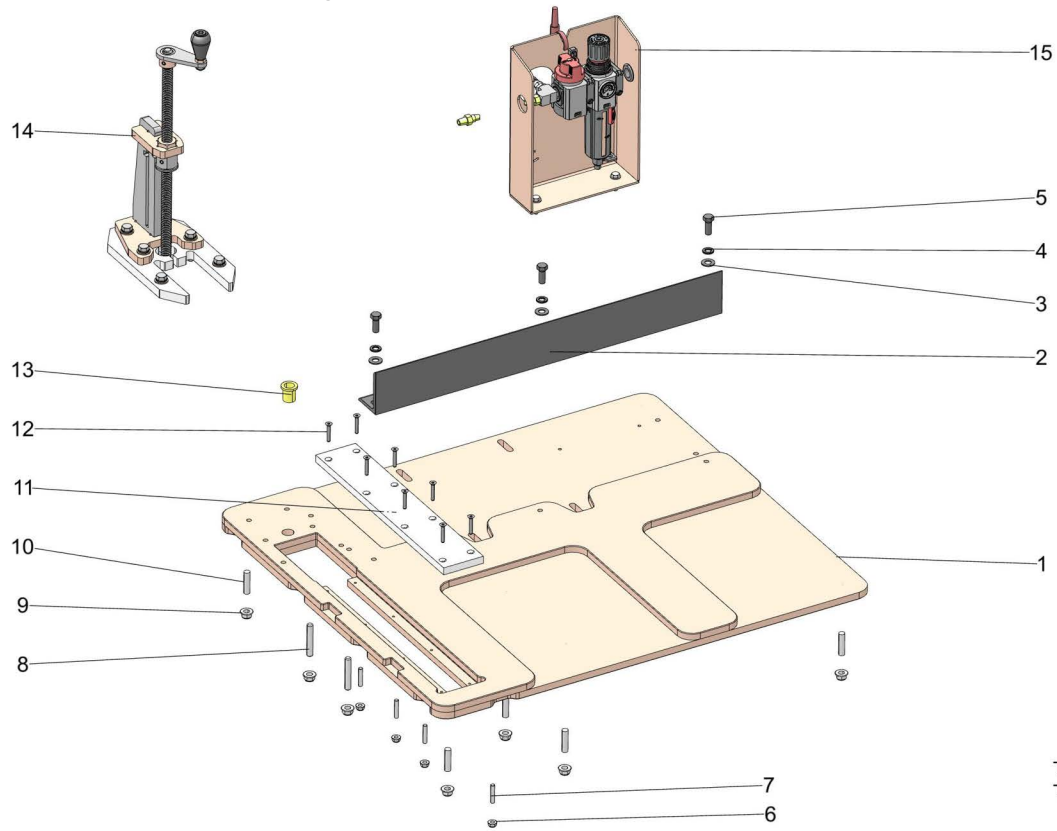

TD122362  
TD122362\_A100

REF	PART #	DESCRIPTION	COMMENTS	QTY.
	122362	TABLE TOP ASSEMBLY - LH		1
	122382	TABLE TOP ASSEMBLY - RH	Right hand configuration not shown.	1
1	122404	Weldment, Top LH		1
	122560	Wldmnt, Top RH	Right hand configuration not shown.	1
2	122418	Angle, Fence		1
3	F05011-3	Washer, 3/8 Flat SAE		3
4	F05011-4	Washer, 3/8 Split Lock		3
5	F05007-87	Bolt, 3/8-16x1 Gr5 HH		3
6	F05010-220	Nut, 1/4-20 Flanged Hex Nylock		4
7	076140	Stud, 1/4-20x1-1/4		4
8	074347	Rod, Threaded 3/8-16UNCx2-1/4		4
9	F05010-222	Nut, 3/8-16 Flanged Hex Nylock		10
10	014702	Stud, 3/8-16x1 1/2 Thrd Rod		6
11	122419	Pad, Throat		1
12	F05005-66	Screw, 1/4-20x1-1/4 FH		8
13	123407	Bushing, 5/8IDx3/4ODx1 Flanged, Bronze		1
14	122408	Assembly, Height Adjust <a href="#">(See Section 8.13)</a>		1
15	122421	Assy, Air Prep, 1/4" NPT <a href="#">(See Section 8.14)</a>		1

### 8.13 Height Adjustment Assembly

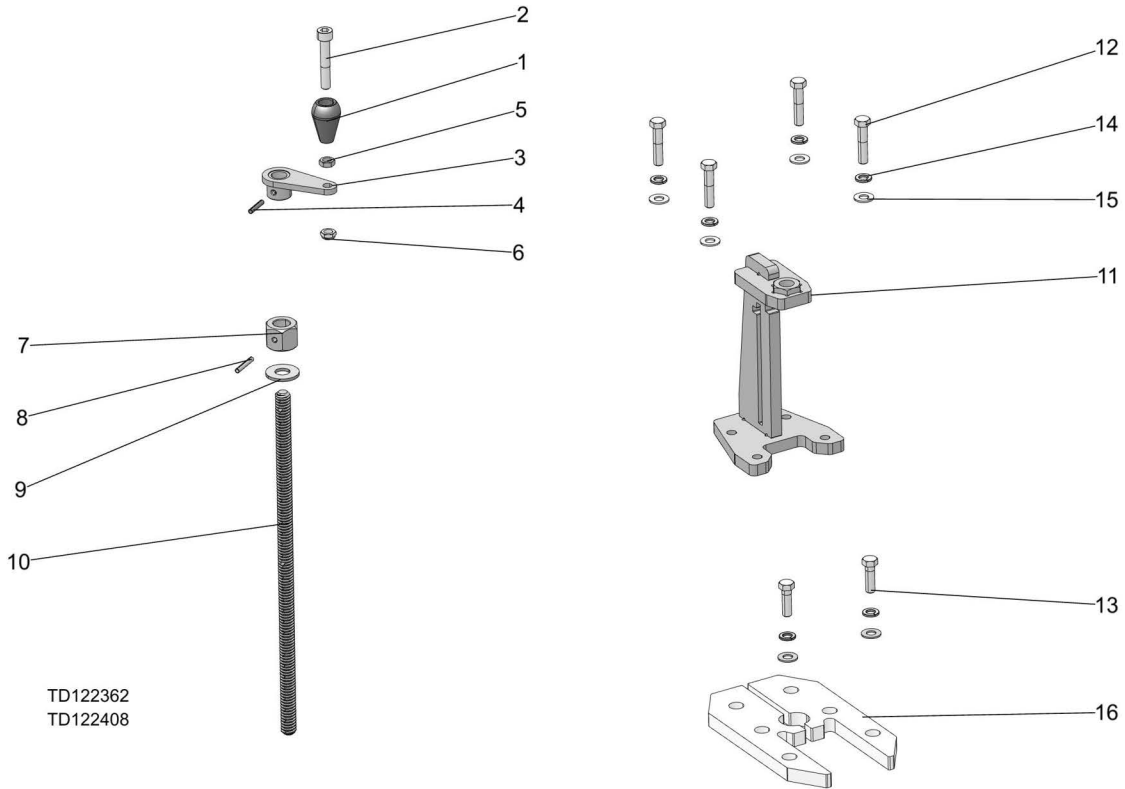

REF	PART #	DESCRIPTION	COMMENTS	QTY.
	122408	<b>HEIGHT ADJUST ASSEMBLY</b>		1
1	060169	Knob, 3/8 Bore Oval/Tapered Plastic		1
2	F05007-177	Bolt, 3/8-16 x 2 1/4 SHC		1
3	122415	Wldmnt, Handle		1
4	F05012-11	Pin, 3/16x1 Zinc Roll		1
5	F05010-29	Nut, 3/8-16 Jam		1
6	F05010-124	Nut, 3/8-16 Half Nylock		1
7	122413	Collar, 5/8 ID x 1 L, Hex		1
8	F05012-16	Pin, 3/16x1 1/4 Roll		1
9	107815	Washer, 5/8x1-3/8x1/8 Nylon, Black		1
10	122414	Shaft, Height Adjust		1
11	122409	Wldmnt, Height Adjust		1
12	F05007-119	Bolt, 3/8-16x1 3/4 HH Gr5		4
13	F05007-123	Bolt, 3/8-16x 1 1/4 HH Gr5		2
14	F05011-4	Washer, 3/8 Split Lock		6
15	F05011-3	Washer, 3/8 Flat SAE		6
16	122375	Pad, Guide		2

## 8.14 Air Prep Assembly

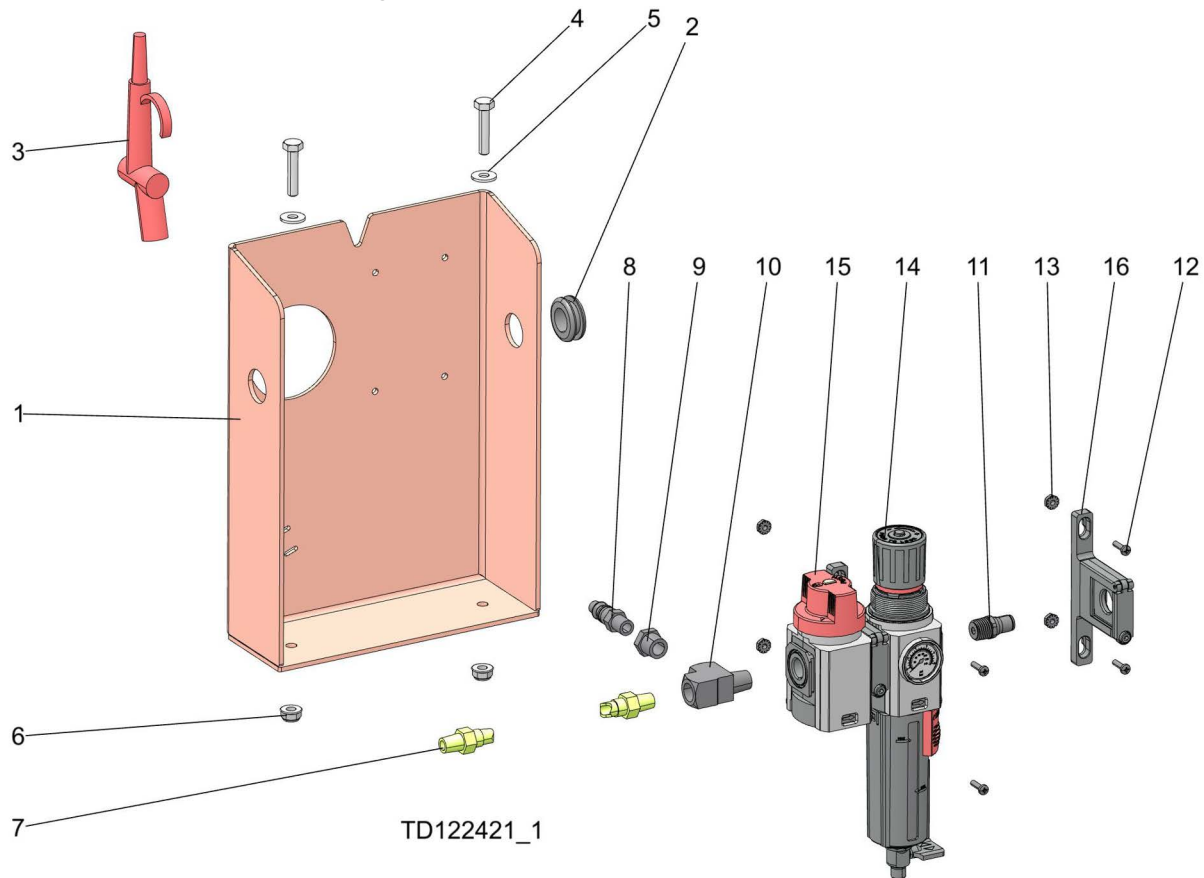

REF	PART #	DESCRIPTION	COMMENTS	QTY.
	122421	<b>ASSY, AIR PREP, 1/4" NPT</b>		1
1	122422	Bracket, Air Prep		1
2	033475	Grommet, 5/8 ID 3/16 GW Rubber		1
3	P02714	Nozzle, Coolant Spray		1
4	F05005-101	Bolt, 1/4-20x1 HH Gr5		2
5	F05011-11	Washer, 1/4 SAE Flat		2
6	F05010-220	Nut, 1/4-20 Flanged Hex Nylock		2
7	042453	Hose, 1/4 x 6 Ft Coiled Air		1
8	P22681	Coupling, 1/8 NPT Male Air		1
9	P22680	Reducer, 1/4npt To 1/8npt		1
10	P05382	Fitting, 1/4 FMF Tee		1
11	106456	Fitting, Air 1/4MPT x 1/4Tubing Str.		1
12	F05015-28	Screw, #6-32X1/2 Phil Pan HD T23, ZN		4
13	F05010-59	Nut, #6-32 Keps		4
	122423	Assy, Filter/Regulator, Air 1/4 NPT		1
14	133067	Regulator, Pnuematic 0-145 PSI		1
15	133066	Valve, Pnuematic Shut Off		1
16	122377	Clamp, Norgren FRL		2

### 8.15 Clamp-Guard Assembly

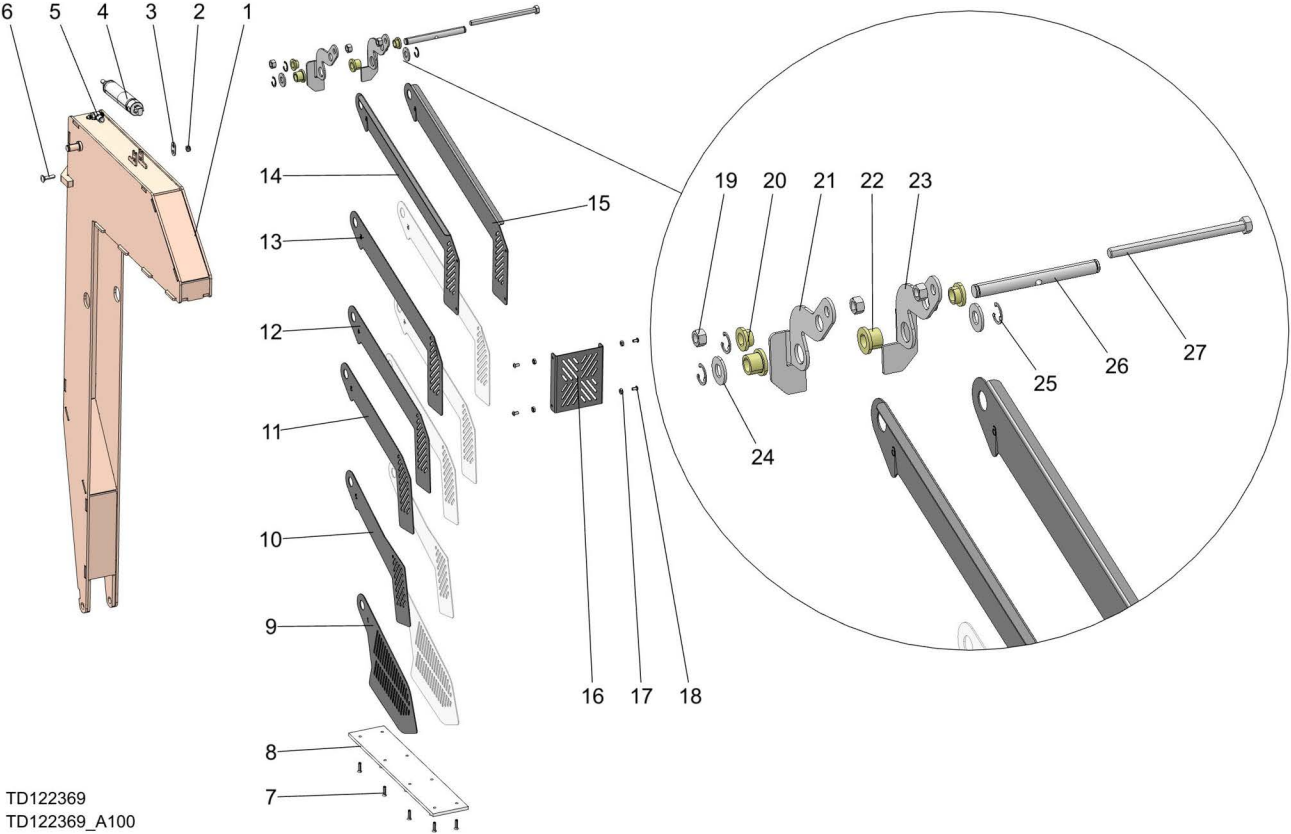

TD122369  
TD122369\_A100

REF	PART #	DESCRIPTION	COMMENTS	QTY.
	122369	<b>CLAMP-GUARD ASSEMBLY</b>		1
1	122451	Wldmnt, Blade Guard		1
2	F05010-156	Nut, 1/4-20 Half Nyl Lock		1
3	122477	Plate, Capture		1
4	122473	Cylinder, 1 1/16 Bore x 2 Stroke, Air		1
5	122474	Valve, 1/8NPT x 1/4Tube, Flow Ctrl		1
6	F05005-34	BOLT, 1/4-20 X 1 CARR		1
7	F05004-159	Screw, 10-24x1 1/4 FH SHC BO		8
8	122461	Pad, Clamp		1
	122462	Auxiliary Guard Assembly		1
9	122471	Plate, Shield 1		2
10	122470	Plate, Shield 2		2
11	122469	Plate, Shield 3		2
12	122468	Plate, Shield 4		2
13	122467	Plate, Shield 5		2
14	122472	Plate, Shield 6 LH		1
15	122466	Plate, Shield 6 RH		1
16	122373	Bracket, Front Shield		1
17	F05010-14	Nut, #10-24 Keps		4
18	F05004-218	Screw, 10-24 x 3/8 BSHS SS		4

REF	PART #	DESCRIPTION	COMMENTS	QTY.
19	F05010-1	Nut, 3/8-16 Hex		3
20	049007	Bushing, 1/2IDx5/8ODx3/8 Long FI		2
21	122464	Bracket, Pivot Lift, LH		1
22	122332	Bushing, 17/32x3/4x1/2 Flanged		2
23	122463	Bracket, Pivot Lift, RH		1
24	F05011-2	Washer, 1/2 SAE Flat		2
25	P22342	E-Clip, 1/2 Dia Shaft Reinforced		4
26	122465	Rod, Linkage		1
27	F05007-34	Bolt, 3/8-16x5 1/2 FT HH Tap		1

### 8.16 Operator Control Assembly

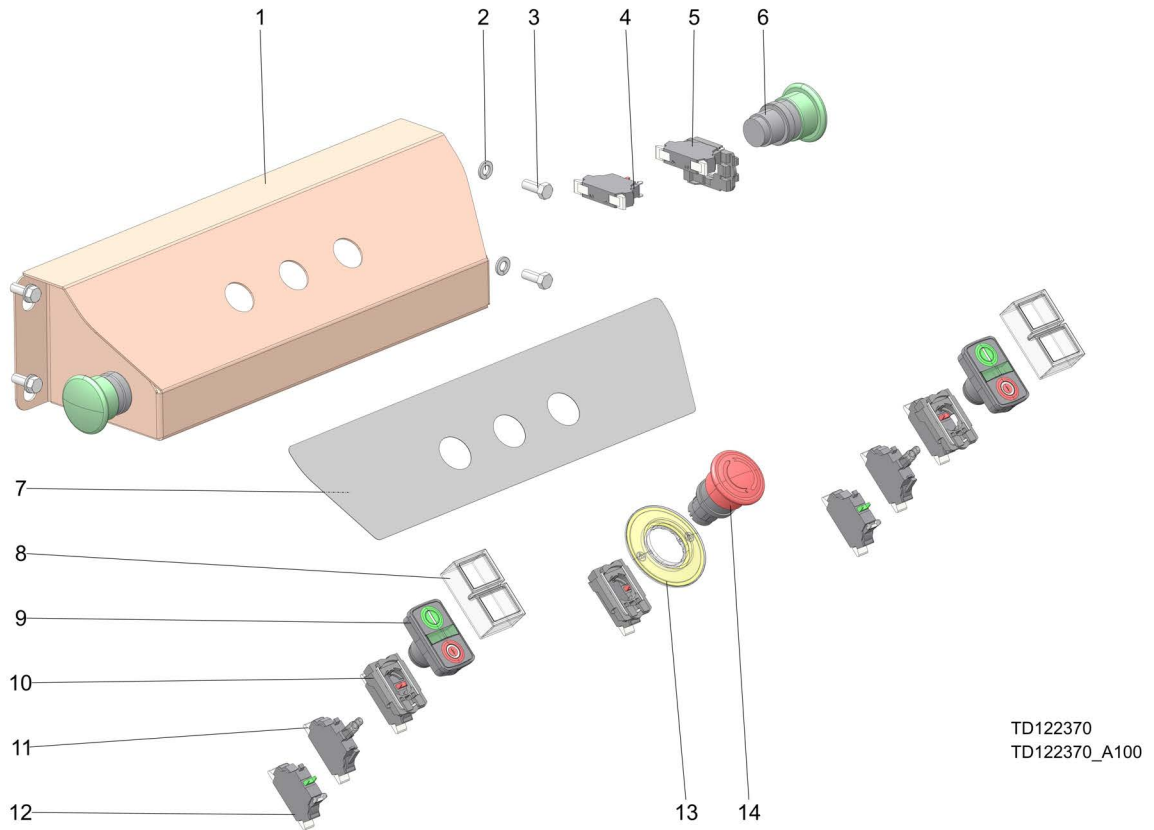

REF	PART #	DESCRIPTION	COMMENTS	QTY.
	122370	<b>OPERATOR CONTROL ASSEMBLY</b>	See Electrical Information for more details.	1
1	122495	Bracket, Control Station		1
2	F05011-14	Washer, 1/4 Split Lock		4
3	F05005-137	Bolt, 1/4-20x5/8 HH GR5		4
4	068921	Contact Block, NC ZB5		1
5	068952	Collar, Mount 1NO ZB5		1
6	131001	Push-Button, Mshrm, Grn, Spg Rtn, ZB5		2
7	121160	Control Overlay, PC100		1
8	052501	Boot, Clear Sealing ZB Sw		2
9	068909	Push-Button, Grn/Red Flush Illuminated		2
10	068950	Collar, Mount 1NC ZB5		3
11	068912	Light Module, White ZB5		2
12	068920	Contact Block, NO ZB5		2
13	050992	Legend, Ø60mm E-Stop		1
14	068940	Push-Button, Mshrm Mntnd Red TrnRI ZB5		1

## 8.17 Electrical Box Assembly

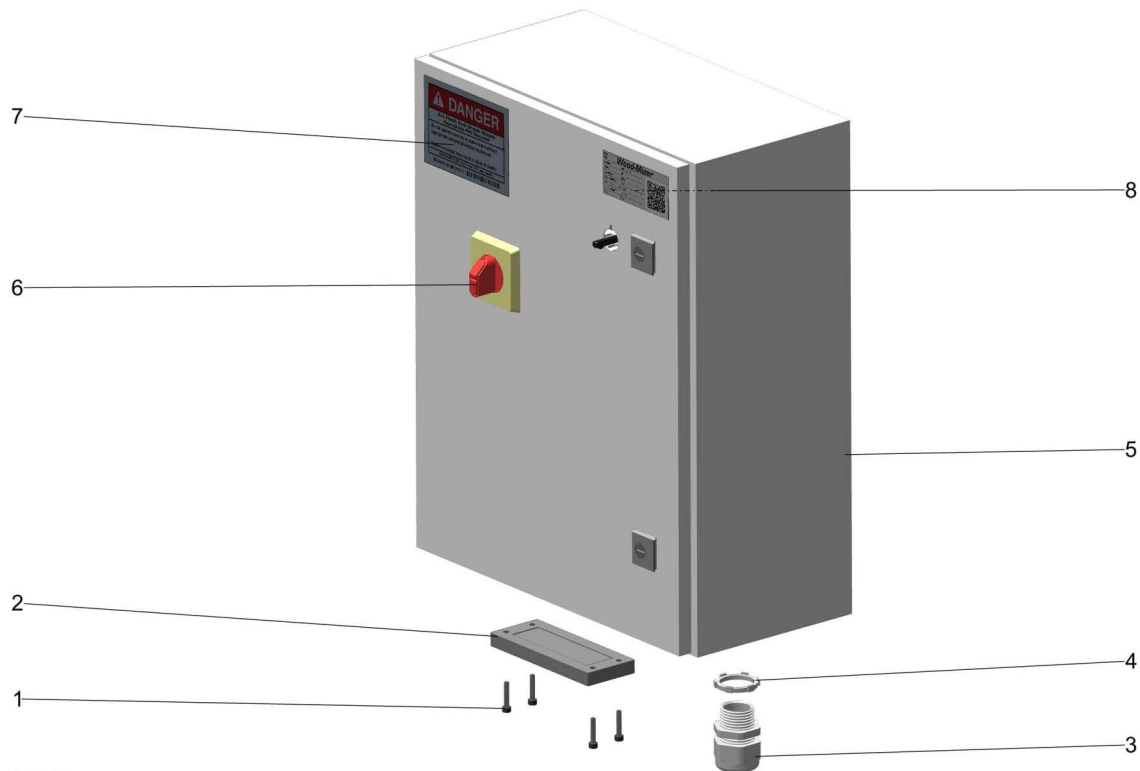

TDPC100LH  
TD121161

REF	PART #	DESCRIPTION	COMMENTS	QTY.
	121163	ASSY, CONTROL ENC, PC100EA 240V 1PH	See Electrical Information for more details.	1
	121162	ASSY, CONTROL ENC, PC100EB 240V 3PH		1
	121161	ASSY, CONTROL ENC, PC100EC 480V 3PH		1
1	F05020-89	Screw, M5x-0.8x25mm SHCS BO PK/50		4
2	121233	Cable Entry Plate, 15 x 7.2-12mm		1
3	069861	Connector, 1" NPT 0.59-1.00		1
4	053735	Nut, 1" NPT Connector Lock Sealing		1
5	121135	Enclosure, Modified, PC100		1
6	050883-1	Handle, Disconnect RED/YEL 6mm Shaft		1
7	068573	Decal, Arc Flash Warning		1
8	121163-NPLBL	Label, 121163 Nameplate		1
	121162-NPLBL	Label, 121162 Nameplate		1
	121161-NPLBL	Label, 121161 Nameplate		1



## 8.18 Decals PC100

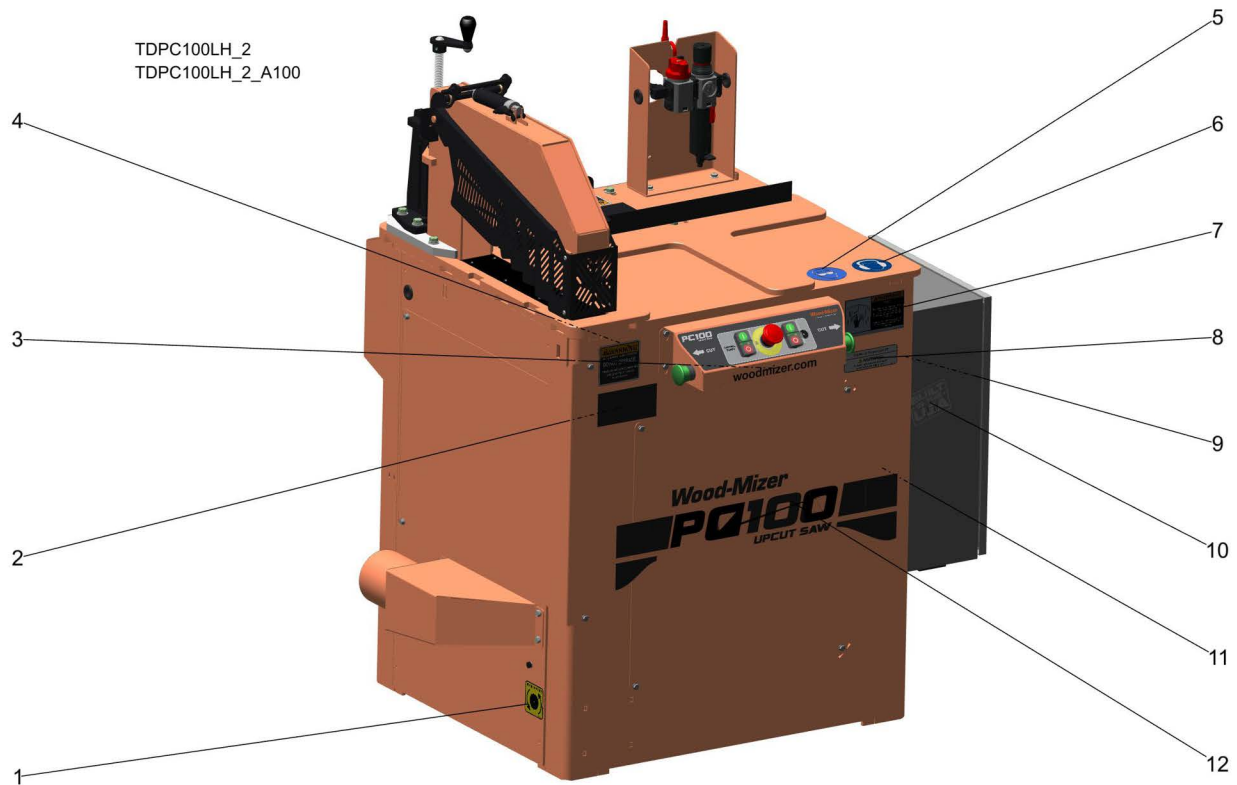

REF	PART #	DESCRIPTION	COMMENTS	QTY.
	122368	<b>DECAL KIT, PC100 - LH</b>		1
1	122512	Decal, Blade Rotation, CW		1
	122513	Decal, Blade Rotation, CW	Right hand configuration not shown.	
2	033254	Decal, Moving Parts Danger		2
3	003235	Decal, Wood-Mizer Website Logo		1
4	040911	Decal, Warning Operate With Guards		2
5	S12004G	Decal, Eye Warning		1
6	S12005G	Decal, Ear Warning		1
7	016402	Decal, Read Manual Warning		1
8	111375	Decal, California Prop 65		1
9	S20061	Decal, Electrical Danger		1
10	074008	Decal, Built In The USA		1
11	122493	Decal, Belt Tension		1
12	122514	Decal, PC100 Front		1

## 8.19 Infeed Table (Optional)

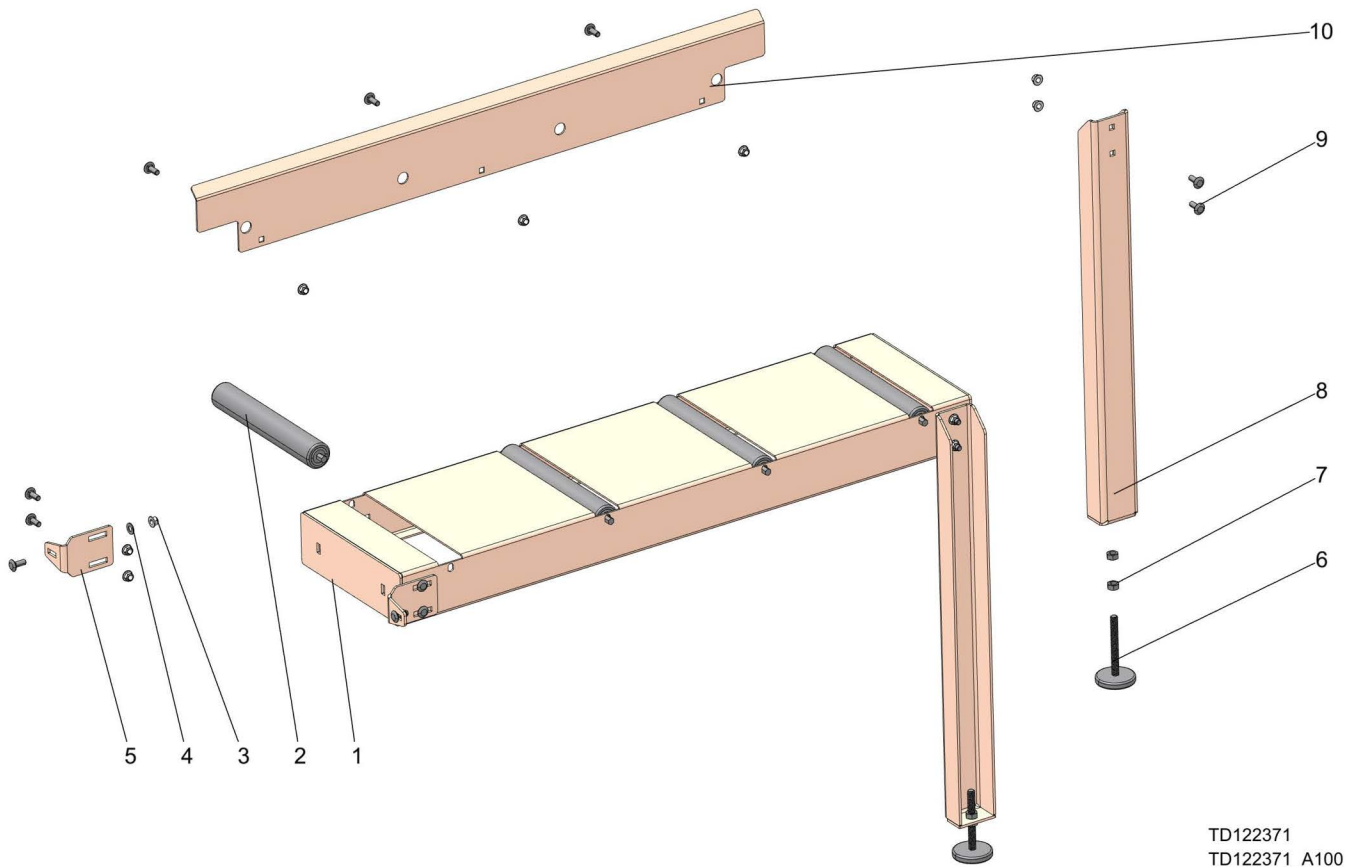

REF	PART #	DESCRIPTION	COMMENTS	QTY.
	122371	<b>INFEEED TABLE ASSEMBLY</b>		1
1	122496	Wldmnt, Feed Table		1
2	059563	Roller, 1.90 ODx12		4
3	F05010-222	Nut, 3/8-16 Flanged Hex Nylock		13
4	F05011-3	Washer, 3/8 Flat SAE		2
5	122500	Bracket, Table Adjustment		2
6	122501	Foot, Leveling, 1/2-13 x 4 1/2 Stud		2
7	F05010-35	NUT, 1/2-13 FREE HEX, ZINC		4
8	122499	Bracket, Leg		2
9	F05007-165	Bolt, 3/8-16x1 Carriage, Zinc Gr 5		13
10	122498	Bracket, Infeed/Outfeed Backstop		1

8.20 Outfeed Table (Optional)

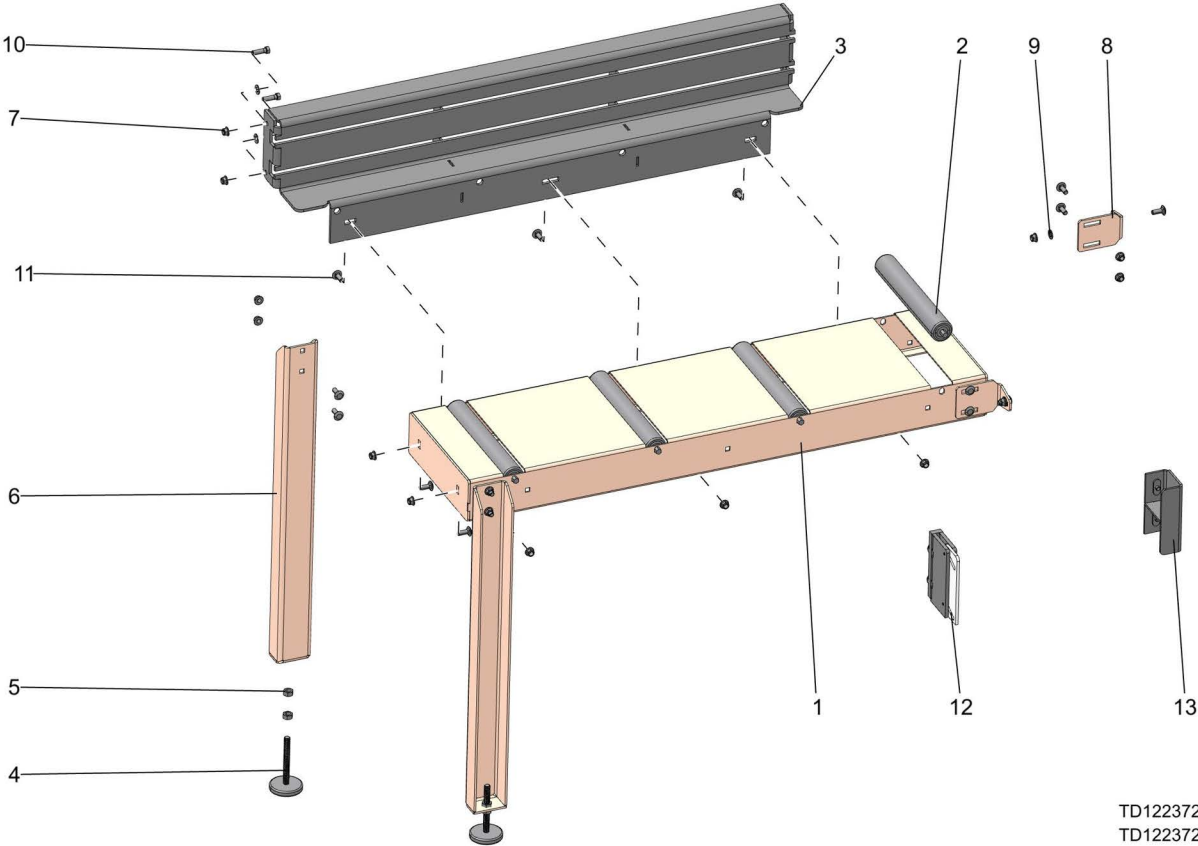

TD122372  
TD122372\_2

REF	PART #	DESCRIPTION	COMMENTS	QTY.
	122372	<b>OUTFEED TABLE ASSEMBLY</b>		1
1	122496	Wldmnt, Feed Table		1
2	059563	Roller, 1.90 ODx12		4
3	134170	Wldmnt, Backer Fence		1
4	122501	Foot, Leveling, 1/2-13 x 4 1/2 Stud		2
5	F05010-35	Nut, 1/2-13 Free Hex, Zinc		4
6	122499	Bracket, Leg		2
7	F05010-222	Nut, 3/8-16 Flanged Hex Nylock		17
8	122500	Bracket, Table Adjustment		2
9	F05011-3	Washer, 3/8 Flat SAE		4
10	F05007-123	Bolt, 3/8-16x1 1/4 FT HH Gr5		2
11	F05007-165	Bolt, 3/8-16x1 Carriage, Zinc Gr 5		15
12	134160	Assembly, Stringer stop 3	<a href="#">(See Section 8.22)</a>	1
13	134176	Assembly, Backstop	<a href="#">(See Section 8.22)</a>	1
	133437	Scale Decal, PC100 Dual Directional	Not shown	1

## 8.21 Outfeed Table Add-on (Optional)

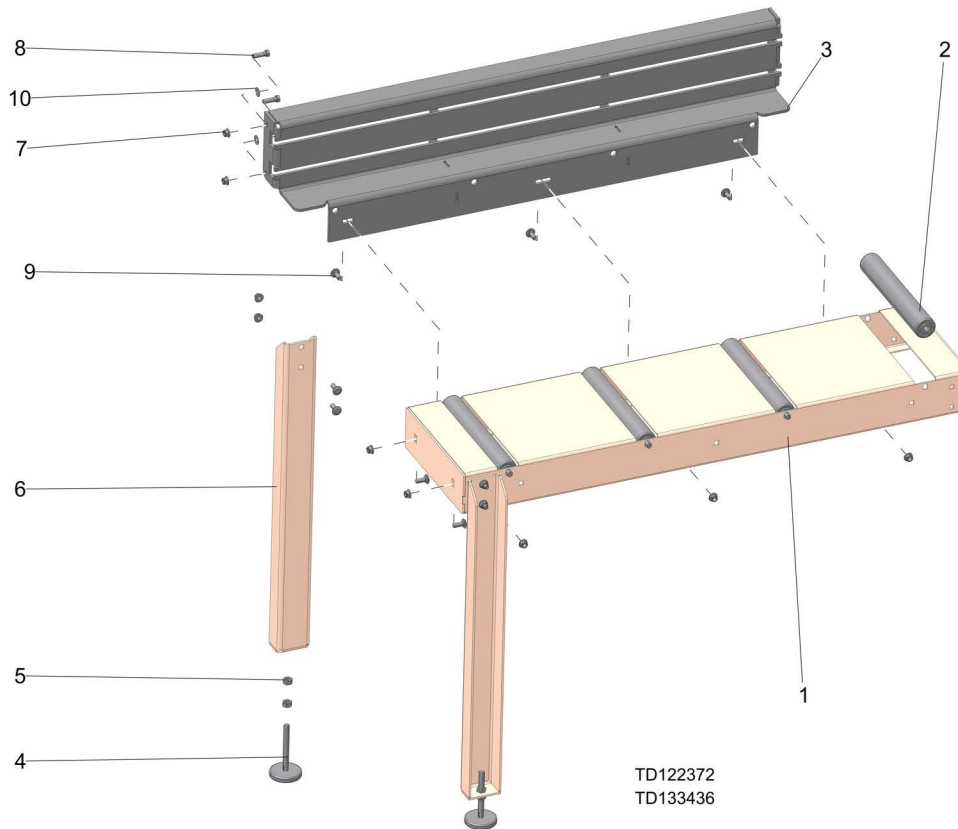

REF	PART #	DESCRIPTION	COMMENTS	QTY.
	133436	<b>OUTFEED TABLE ADDITIONAL ASSEMBLY</b>		1
1	122496	Weldment, Feed Table		1
2	059563	Roller, 1.90 ODx12		4
3	134170	Wldmnt, Backer Fence		1
4	122501	Foot, Leveling, 1/2-13 x 4 1/2 Stud		2
5	F05010-35	NUT, 1/2-13 FREE HEX, ZINC		4
6	122499	Bracket, Leg		2
7	F05010-222	Nut, 3/8-16 Flanged Hex Nylock		11
8	F05007-123	Bolt, 3/8-16x 1 1/4 HH Gr5		2
9	F05007-165	Bolt, 3/8-16x1 Carriage, Zinc Gr 5		9
10	F05011-3	Washer, 3/8 SAE Flat		2

## 8.22 Outfeed Stops

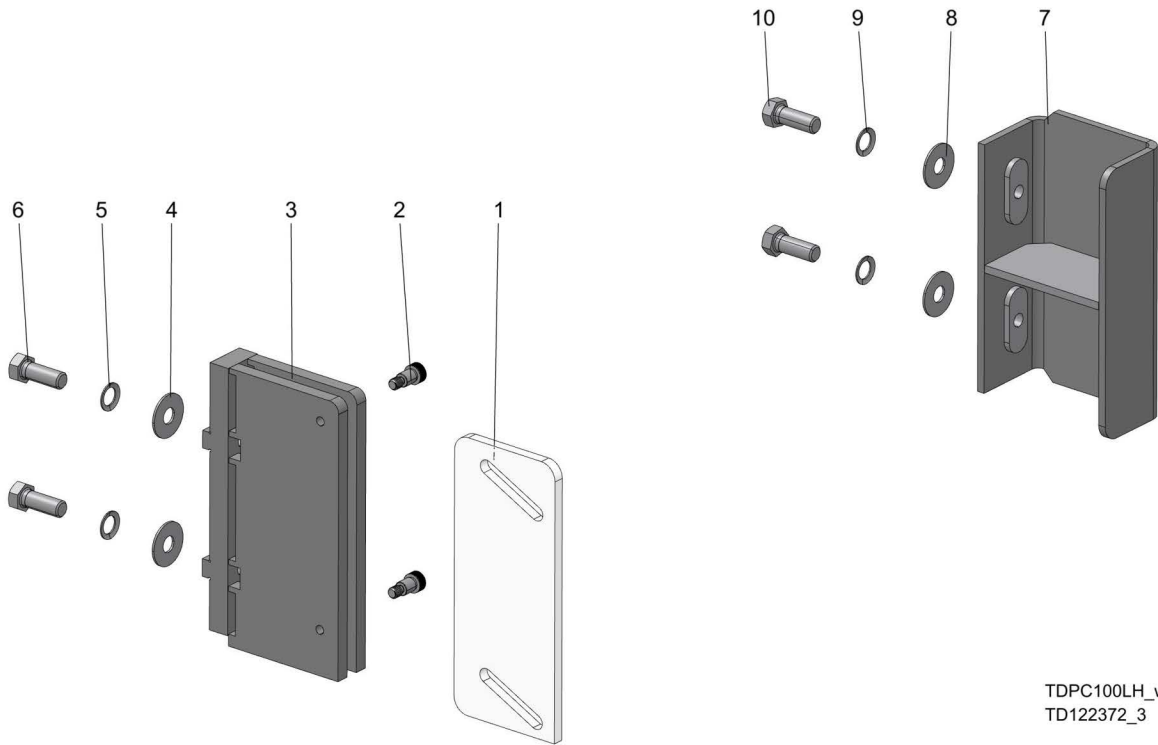

TDPC100LH\_w\_t  
TD122372\_3

REF	PART #	DESCRIPTION	COMMENTS	QTY.
	134160	<b>STRINGER STOP ASSEMBLY</b>	Included with optional outfeed table	1
1	134164	Plate, Stringer stop 3		1
2	F05006-189	Bolt, Shoulder, 1/4-28, 97832A322		2
3	134161	Weldment, Stringer Stop		1
4	F05011-126	Washer, 3/8 Standard Flat		2
5	F05011-86	Washer, 3/8 Belleville Serrated Both Sides		2
6	F05007-87	Bolt, 3/8-16x1 Gr5 HH		2
	134176	<b>BACKSTOP ASSEMBLY</b>	Included with optional outfeed table	1
7	134175	Weldment, Backstop Section		1
8	F05011-126	Washer, 3/8 Standard Flat		2
9	F05011-86	Washer, 3/8 Belleville Serrated Both Sides		2
10	F05007-87	Bolt, 3/8-16x1 Gr5 HH		2

## 8.23 Gang Stop (Optional)

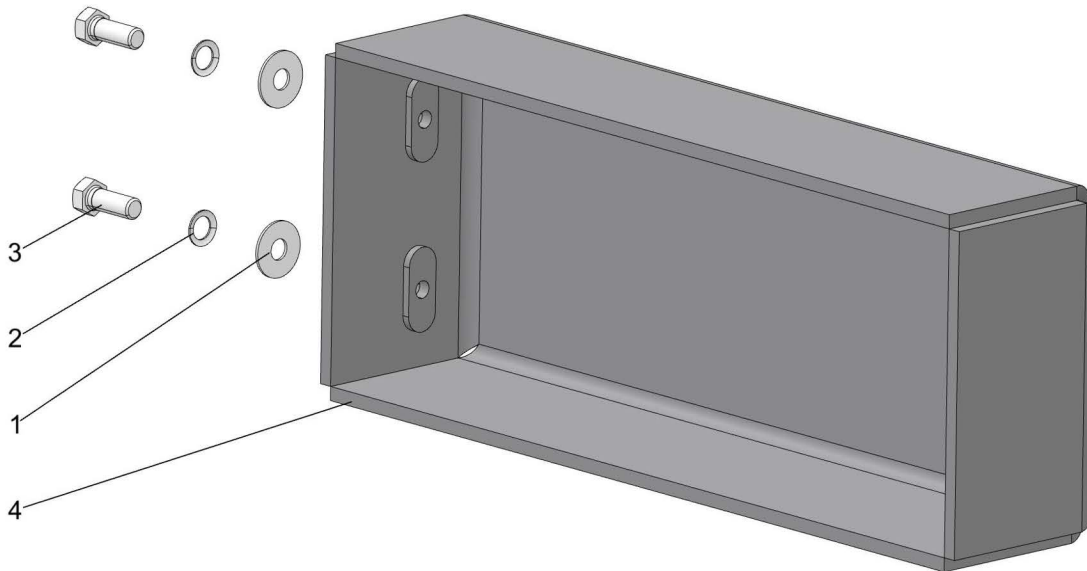

TD134189

REF	PART #	DESCRIPTION	COMMENTS	QTY.
	134189	<b>GANG STOP ASSEMBLY</b>	Optional Accessory	1
1	F05011-126	Washer, 3/8 Standard Flat		2
2	F05011-86	Washer, 3/8 Belleville Serrated Both Sides		2
3	F05007-87	Bolt, 3/8-16x1 Gr5 HH		2
4	134190	Weldment, Gang stop		1



### 8.24 Lower Chute Bracket Kit (Optional)

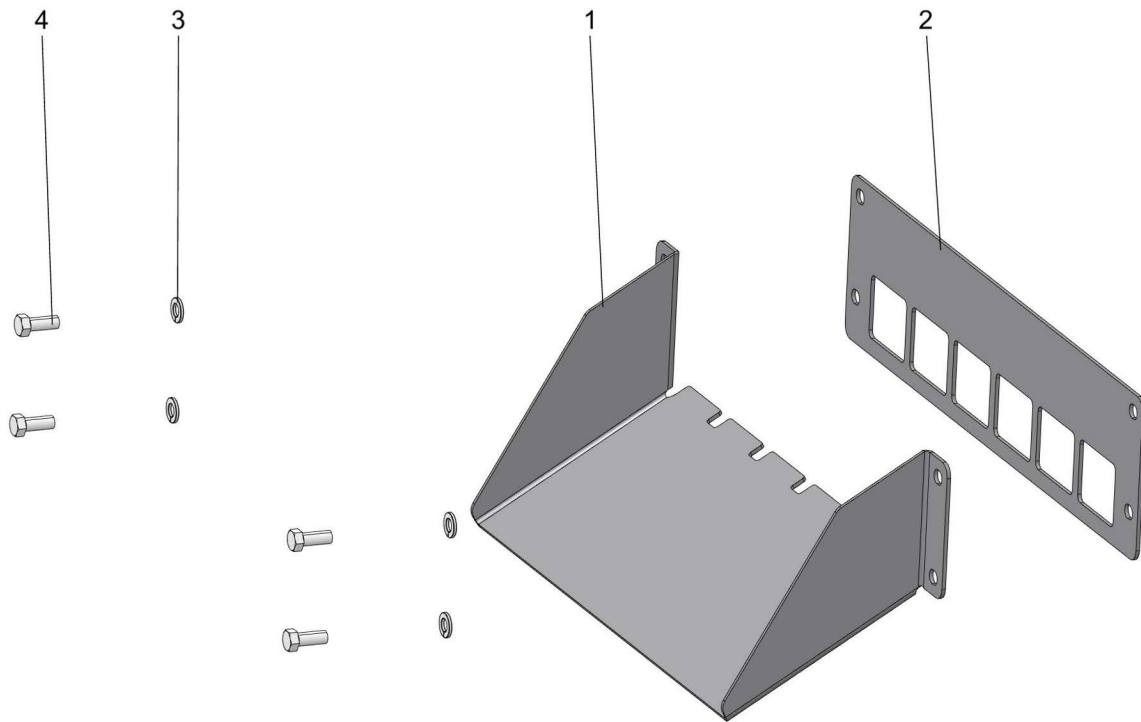

TD133423

REF	PART #	DESCRIPTION	COMMENTS	QTY.
	133423	<b>KIT, LOWER CHUTE BRACKET</b>		1
<b>1</b>	122544	Bracket, Lower Chute		1
<b>2</b>	133413	Plate, Lower Chute Bracket		1
<b>3</b>	F05011-14	Washer, 1/4 Split Lock		4
<b>4</b>	F05005-137	Bolt, 1/4-20x5/8 HH GR5		4

## SECTION 9 TROUBLESHOOTING



**DANGER!** Disconnect power before clearing debris or **any other maintenance activity**. Failure to follow this will result in serious injury or death.

Follow the OSHA lockout procedures reprinted in the Safety section.

Keep hands away from the blade.

Do not operate the PC100 without all covers and guards in place.

Problem	Possible Cause	Solution
Saw clamp not contacting material	1. Dust/debris buildup in cabinet on mechanical parts.	1. Open access panels and clean dust and debris. 2. Utilize minimum 500 CFM dust collection system if cutting new lumber.
Blade will not engage	1. Safety switches not fully depressed.	1. Tighten loose screws on all access panels.