

**MD400, MD500 Chip Extractor:  
Safety, Operation,  
Maintenance, and Parts Manual**

---

<b>MD400</b>	<b>B1.00</b>
<b>MD500</b>	<b>B1.00</b>

---

***Safety is our #1 concern!***

*Form #2358-US*

**MODELS EFFECTED:**

MD400EA3U  
MD400EA3U-A  
MD400EA3U-SYS  
MD400EA3U-SYS-A  
MD400EB3U  
MD400EB3U-A  
MD400EB3U-SYS  
MD400EB3U-SYS-A  
MD500EB5U  
MD500EB5U-A  
MD500EB5U-SYS  
MD500EB5U-SYS-A



**WARNING! Read and understand this manual before using this machine.**

**California**  
Proposition 65 Warning



**WARNING:** Breathing gas/diesel engine exhaust exposes you to chemicals known to the State of California to cause cancer and birth defects or other reproductive harm.

Always start and operate the engine in a well-ventilated area.  
If in an enclosed area, vent the exhaust to the outside.  
Do not modify or tamper with the exhaust system.  
Do not idle the engine except as necessary.

For more information go to **[www.P65warnings.ca.gov](http://www.P65warnings.ca.gov)**.



**WARNING:** Drilling, sawing, sanding or machining wood products can expose you to wood dust, a substance known to the State of California to cause cancer. Avoid inhaling wood dust or use a dust mask or other safeguards for personal protection.

For more information go to **[www.P65Warnings.ca.gov/wood](http://www.P65Warnings.ca.gov/wood)**.

**Active Patents assigned to Wood-Mizer, LLC**

Wood-Mizer, LLC has received patents that protect our inventions which are a result of a dedication to research, innovation, development, and design. Learn more at: [woodmizer.com/patents](http://woodmizer.com/patents)

**©2024 Wood-Mizer LLC**

Printed in the United States of America, all rights reserved. No part of this manual may be reproduced in any form by any photographic, electronic, mechanical or other means or used in any information storage and retrieval system without written permission from

**Wood-Mizer, LLC**  
**8180 West 10th Street**  
**Indianapolis, Indiana 46214**

**SECTION 1 INTRODUCTION**

1.1 About This Manual ..... 1-1  
1.2 Getting Service..... 1-1

**SECTION 2 GENERAL SAFETY**

2.1 Safety Symbols ..... 2-1  
2.2 Safety Instructions..... 2-1

**SECTION 3 SPECIFICATIONS**

3.1 Specifications of MD400 and MD500 chip extractors ..... 3-1  
3.2 Overall dimensions ..... 3-3

**SECTION 4 SETUP**

4.1 Attaching the Chip Extractor ..... 4-1  
4.2 Optional Cyclone Twin Bag Collector Assembly..... 4-1

**SECTION 5 OPERATION**

5.1 General Use..... 5-1  
5.2 Site Preparation ..... 5-1  
5.3 Extractor Operation..... 5-1  
5.4 Collection System Operation ..... 5-1

**SECTION 6 TROUBLESHOOTING GUIDE**

6.1 General Troubleshooting..... 6-1  
6.2 Extractor Optimization..... 6-2

**SECTION 7 GENERAL INFORMATION**

7.1 How To Use The Parts List..... 7-1  
7.2 Chip Extractor, 3kW 230v Single Phase, 3kW 230v Three-Phase ..... 7-2  
7.3 Chip Extractor, 3kW 230v Three-Phase ..... 7-3  
7.4 Motor/Fan Drive, 3kW, Single-Phase..... 7-4  
7.5 Motor/Fan Drive, 3kW, Three-Phase..... 7-5  
7.6 Motor/Fan Drive, 5.5kW Three-Phase..... 7-6  
7.7 Motor Starter ..... 7-7  
7.8 3x4", 1x5" Inlet ..... 7-8  
7.9 5x4" + 1x5" Inlet..... 7-9  
7.10 10" Inlet..... 7-10  
7.11 8" Outlet ..... 7-11  
7.12 2x8" Outlet ..... 7-12  
7.13 10" Outlet ..... 7-13  
7.14 Mounting Feet ..... 7-14  
7.15 Bagging System ..... 7-15  
7.16 Bag Clamp..... 7-17

**Wood-Mizer® LLC**  
**Limited Product Warranty**



Wood-Mizer LLC (“Warrantor”), an Indiana corporation with its principal place of business at 8180 West Tenth Street, Indianapolis, IN 46214-2400 USA, warrants to the purchaser (“Purchaser”) that for the time periods specifically stated herein and subject to the terms, conditions and limitations stated herein, the equipment manufactured by the Warrantor will be free from defects in material and workmanship attributable to Warrantor so long as, during the warranty periods stated herein, the equipment is installed, operated and maintained in accordance with the instructions provided by Warrantor.

PRODUCT	MODEL CLASS	LENGTH OF WARRANTY		EFFECTIVE DATE
		USA & CANADA	NON USA & CANADA	
Portable Sawmills, Resaws, Edgers	LT, LX, HR, EG	Two years	One year	Date of purchase
Portable Sawmills with Chassis	LT28, LT35, LT40, LT50, LT70, LX450	Two years, excluding the chassis, which chassis shall have a five year warranty	One year	
Industrial Sawmills, Resaws, Edgers	WM, HR, EG, TVS, SVS	One year	One year	Date of purchase or date of installation / training (if applicable), whichever occurs first, not to exceed 6 months from date of purchase
TITAN Industrial	WB, TV, HR, EG, EA, MR	One year	One year	
Material Handling	TWC, IC, TD, LD, GC, CR, CB, CC	One year	One year	
Blade Maintenance Equipment	BMS, BMT, BMST	One year	One year	Date of purchase
Options and Accessories	Various	One year*	One year*	
Moulders, Extractors, Kilns	MP, MD, KS, KD	One year	One year	
Slab Flattener	MB	Two years	One year	
Pallet Equipment	PD, PC	One year	One year	
Log Splitters	FS	One year	One year	
Replacement Parts	Various	90 days	90 days	

\* Warranty on Options will match the warranty on the primary equipment when purchased on same invoice.

**Exclusions from 90 Day, Limited One Year and Two Year Warranty**

Warrantor shall have **no** responsibility under this warranty for any wear components, including, but not limited to: belts, blade guides, blades, electric motor brushes, drum switches, filters, fuses, hoses, bearings (excluding cylindrical drive bearings), bushings, cable carriers, and spark plugs. All wear components are furnished “as is”, without any warranty from Warrantor. This limited warranty does not cover any defects caused by misuse, negligence, alterations, damage due to overload, abnormal conditions, excessive operation, accident, or lack of performance of normal maintenance services.

Several components which are used in the manufacture of the equipment but not manufactured by Warrantor such as cant hooks, power plants, laser sights, batteries, tires, and trailer axles have warranties provided by the original equipment manufacturer (written copies available upon request). Warrantor does not separately warrant such items. Components or equipment manufactured by third parties are not covered by this warranty. Warrantor, however, will provide reasonable assistance to the Purchaser to make claims against any warranties applicable to such component parts as provided by such original equipment manufacturers. Components or equipment manufactured by third parties are not covered by this Warranty.

**Five Year Limited Chassis Warranty**

The limited five year chassis warranty described above, DOES NOT extend to (a) any damage stemming from accident, improper towing, overload, abuse, misuse, abnormal conditions, negligence, excessive operation, or lack of maintenance, (b) rust caused by exposure to corrosive atmospheric conditions, or (c) the sawmill head, carriage, axle, brakes, or any hydraulic or electrical components attached to the chassis.

**Warrantor's Obligations as To Defects**

In the event that the equipment fails to perform due to defective materials or workmanship attributable to Warrantor under normal use and service within the established warranty period, Purchaser's sole and exclusive remedy and Warrantor's sole liability shall be to replace or repair, in Warrantor's sole and subjective discretion, any defective part at Warrantor's principal place of business without cost to the Purchaser if such defect exists. The determination of whether a product is defective shall be made by Warrantor in Warrantor's sole and subjective discretion. The Purchaser must notify Warrantor prior to shipping any defective part. Warrantor, at its sole discretion, may cover expenses incurred in shipping the defective part to Warrantor for evaluation; provided, however, that Warrantor will not be responsible for labor, travel time, mileage, removal, installation or incidental or consequential damages. However, any part in excess of 140 pounds must be returned by the Purchaser, to the Warrantor's nearest authorized facility at the Purchaser's expense, if return is requested by Warrantor. Warrantor shall have a reasonable time within which to replace or repair the defective part. If Warrantor determines that the product is not defective under the terms of this warranty in Warrantor's sole and subjective discretion, then Purchaser shall be responsible for any expenses incurred by Warrantor in returning the equipment to the Purchaser.

**Limitations and Disclaimers of Other Warranties**

EXCEPT FOR THE EXPRESS WARRANTY PROVISIONS STATED ABOVE, WARRANTOR DISCLAIMS ALL WARRANTIES, EXPRESS AND/OR IMPLIED, INCLUDING WITHOUT LIMITATION, THE IMPLIED WARRANTIES OF MERCHANTABILITY, AND FITNESS FOR A PARTICULAR PURPOSE, NONINFRINGEMENT AND TITLE. No representation or other affirmation of fact by representatives of Warrantor, whether verbal or in writing, including photographs, brochures, samples, models, or other sales aids, shall constitute a warranty or other basis for any legal action against Warrantor. There are no other representations, promises, agreements, covenants, warranties, guarantees, stipulations or conditions, express or implied, by Warrantor except as expressly set forth herein. THE ORIGINAL PURCHASER AND ANY INTENDED USER OR BENEFICIARY OF THIS EQUIPMENT, SHALL NOT BE ENTITLED TO RECOVER ANY INDIRECT, SPECIAL, PUNITIVE, EXEMPLARY, CONSEQUENTIAL, SPECIAL, OR INCIDENTAL DAMAGES OR LOSSES, INCLUDING BUT NOT LIMITED TO, DAMAGES OF LOST PRODUCTION, LOST REVENUE, LOST PRODUCT, LOST PROFITS, LOST BUSINESS, LOSS OF USE, LOSS OF GOODWILL, OR BUSINESS INTERRUPTION, FROM WARRANTOR FOR ANY REASON WHATSOEVER INCLUDING WITHOUT LIMITATION WARRANTY OR DEFECT IN THE PRODUCT REGARDLESS OF THE SOLE, JOINT AND/OR CONCURRENT NEGLIGENCE, BREACH OF CONTRACT, BREACH OF WARRANTY, STRICT LIABILITY IN TORT OR STATUTORY CLAIMS OR OTHER LEGAL FAULT OR RESPONSIBILITY OF EITHER WARRANTOR OR PURCHASER OR ITS EMPLOYEES OR AGENTS. Warrantor does not warrant that its equipment meets or complies with the requirements of any particular safety code or governmental requirements.

Defective items replaced under the terms of this warranty become the property of Warrantor.

**Design Changes**

Warrantor reserves the right to change the design of its products from time to time without notice and without obligation to make corresponding changes in or to its products previously manufactured.

**Rights of Purchasers**

The validity and effect of this limited warranty as well as its interpretation, operation and effect, shall be determined exclusively by the principles of law and equity of the State of Indiana, USA. This limited warranty gives Purchaser specific legal rights. Purchaser may also have other rights, which may vary from state to state. Some states may not allow limitations as to the duration of implied warranties or to the exclusion or limitation of incidental or consequential damages, so some of the limitations and exclusions detailed set forth above may not apply. In the event that any one or more of the provisions of this warranty shall be or become invalid, illegal or unenforceable in any respect, the validity, legality and enforceability of the remaining provisions of this warranty shall not be affected thereby.

**Interpretations**

This Warranty constitutes the entire warranty agreement between Warrantor and Purchaser and supersedes any prior understandings or agreements pertaining to the same subject matter. This warranty cannot be amended except in writing which refers to this warranty which is signed by both Warrantor and Purchaser.

## **SECTION 1 INTRODUCTION**

### **1.1 About This Manual**

This manual replaces any previous information received on your Wood-Mizer® equipment.

The information and instructions in this manual do not amend or extend the limited warranties for the equipment given at the time of purchase.

### **1.2 Getting Service**

For contact information, sales, service, parts, and additional manuals, sign into your account on <https://wood-mizer.com>.

## SECTION 2 GENERAL SAFETY

### 2.1 Safety Symbols

The following symbols and signal words call your attention to instructions concerning your personal safety. Be sure to observe and follow these instructions.



**DANGER!** indicates an imminently hazardous situation which, if not avoided, will result in serious injury or death.



**WARNING!** suggests a potentially hazardous situation which, if not avoided, could result in serious injury or death.



**CAUTION!** refers to potentially hazardous situations which, if not avoided, may result in minor or moderate injury or damage to equipment.

**NOTICE** indicates vital information.

### 2.2 Safety Instructions

#### OWNER/OPERATOR'S RESPONSIBILITY

The procedures listed in this manual may not include all ANSI, OSHA, or locally required safety procedures. **It is the owner/operator's responsibility and not Wood-Mizer LLC to ensure all operators are properly trained and informed of all safety protocols.** Owner/Operators are responsible for following all safety procedures when operating and performing maintenance to the equipment.

#### **Observe ALL Safety Instructions**

**NOTICE** Read the entire Operator's Manual before operating this equipment.

Note all safety warnings throughout this manual and those posted on the machine.

Be able to access this manual at all times while operating this equipment.

Read additional manufacturer's manuals and observe their applicable safety instructions.

Only persons who have read and understood the entire operator's manual should operate this equipment.

This equipment is not intended for use by or around children.

**It is the owner/operator's responsibility to comply with all applicable federal, state, and local laws, rules, and regulations regarding the ownership, operation, and transporting your equipment.**

Operators should become thoroughly familiar with and comply with these applicable laws for operating and transporting equipment.

## SECTION 3 SPECIFICATIONS

### 3.1 Specifications of MD400 and MD500 chip extractors

Wood-Mizer chip extractors nomenclature is given in the table below.

Chip Extractor Model	MD400EA3U	MD400EB3U	MD500EB5U
<b>Motor Type</b>	Electric Motor	Electric Motor	Electric Motor
<b>Rated Voltage</b>	1x230 V	3x230 V	3x230 V
<b>Mass</b>			
<b>Rated power</b>	3 kW	3 kW	5.5 kW
<b>HP</b>	4	4	7.5
<b>Flow rate</b>	2350 CFM (4000 m <sup>3</sup> /h)	2350 CFM (4000 m <sup>3</sup> /h)	2940 CFM (5000 m <sup>3</sup> /h)

MD400 Overview:



FIG. 3-1

MD500 Overview:

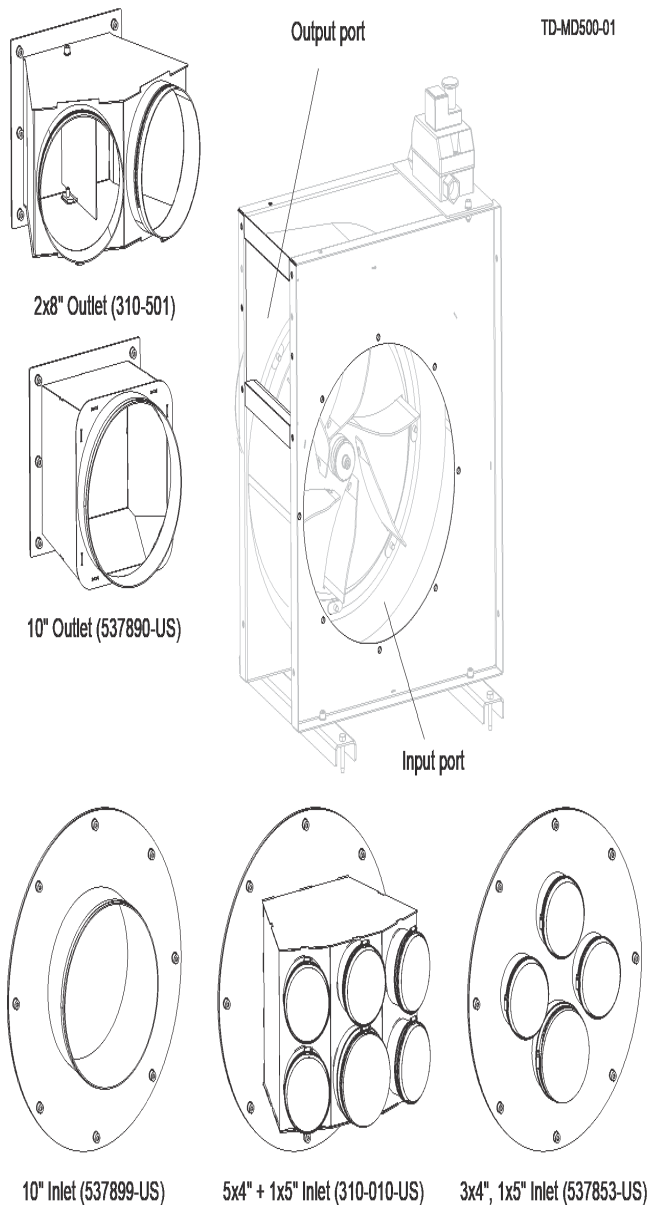

**FIG. 3-2**

When using a collection system, keep in mind:

- Check your local waste disposal codes before designing your chip collection system.
- Design access to your chip collection bins so that they can be easily emptied.
- Short hose runs and smooth-walled hoses reduce suction loss within the system.
- Locate the chip collector near the planer moulder.
- Collection systems are loud; use ear protection.
- If you are operating this machine in a climate-controlled building and blowing the chips outside, the vacuum created by the chip collector can quickly empty your building of its heated or cooled air.
- If blowing the chips to an indoor bin, an air filter will be necessary to prevent wood dust from reducing the air quality inside of your building.
- If selling chips for use with livestock, do not use harsh chemicals for cleaning or lubricating machinery



### 3.2 Overall dimensions

The overall dimensions of both MD400 and MD500 chip extractors and the bagging system are shown below (all dimensions in foot-inches).

#### MD 400 Layout

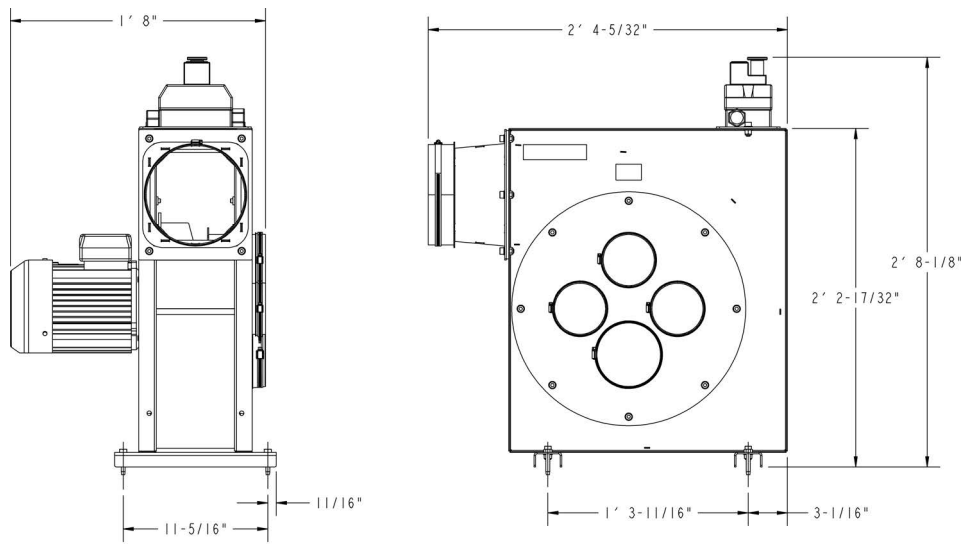

Feet and starter box may be mounted on any side

**FIG. 3-3**

#### MD500 Layout

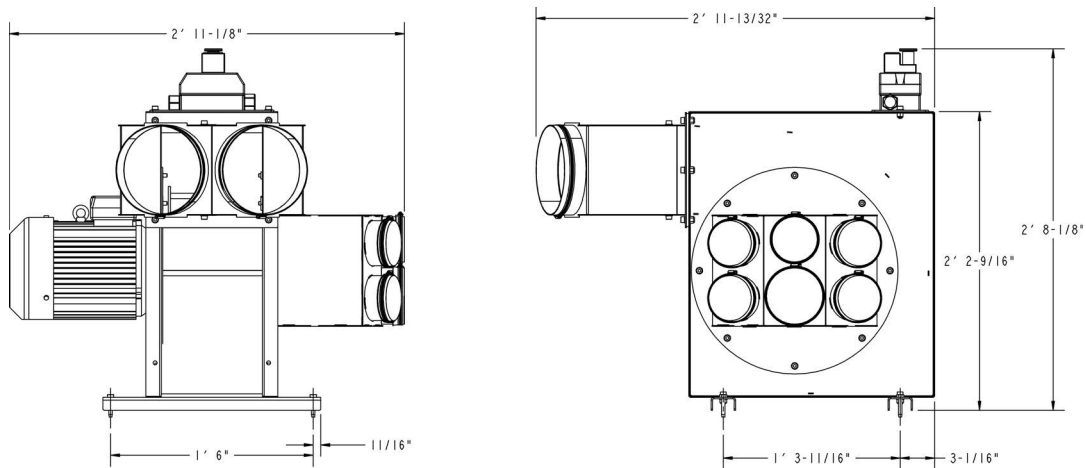

Shown with 5x4"+1x5" inlet and 2x8" outlet options  
Feet and starter box may be mounted on any side

**FIG. 3-4**

Bag Collector Assembly Layout

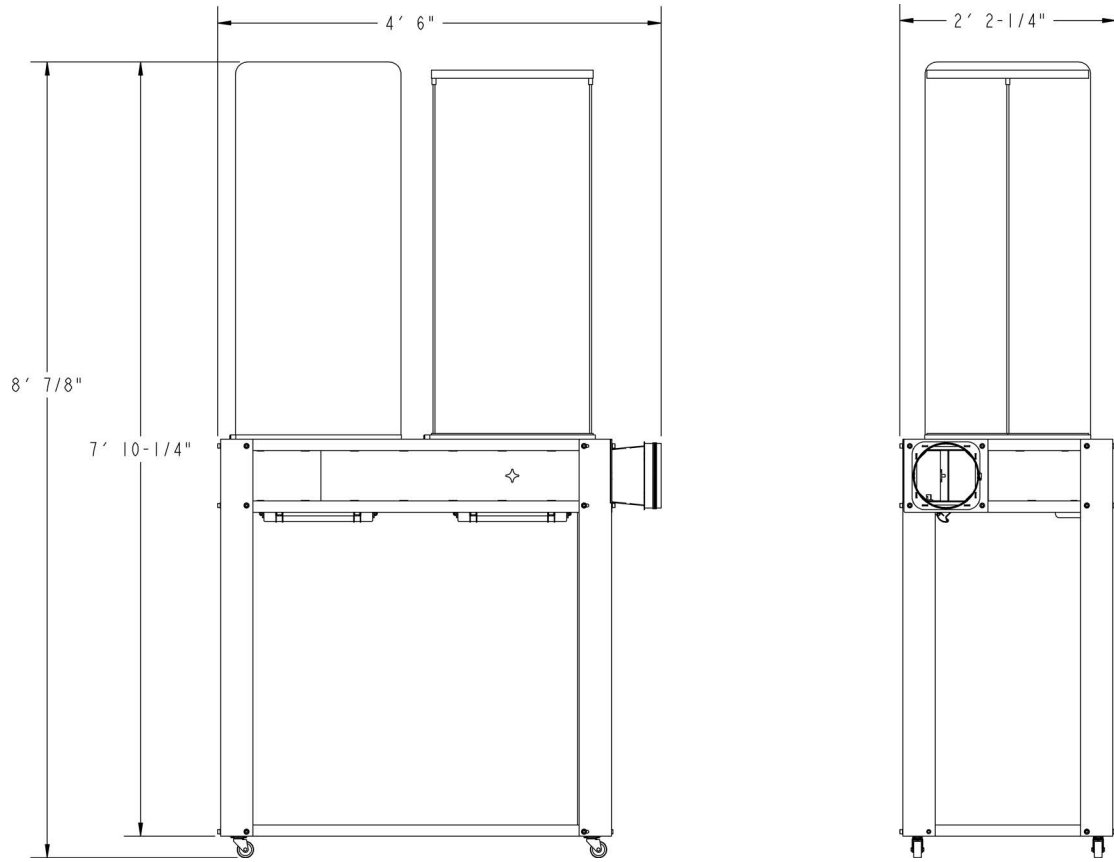

**FIG. 3-5**

## SECTION 4 SETUP

### 4.1 Attaching the Chip Extractor

**NOTICE** Do not use your Chip Extractor if flexible hoses are not attached to it.

All unused ports must be securely blocked off. Do not run your Chip Extractor with open ports.

The Chip Extractor is attached to external units by means of flexible hoses. The ports fit within the hose, and are fastened with conventional hose clamps. No special accommodations are required.



**FIG. 4-1**

### 4.2 Optional Cyclone Twin Bag Collector Assembly

Tools needed for the assembly are a 6mm hex key and a 13mm open end wrench. A power drill is recommended.

1. Unpack your Cyclone Twin Bag Collector and check that all parts are present:

- (2) Collection bags
- (2) Bag locks
- (3) Legs (no cutouts)
- (1) Frame
- (14) Short 6mm hex screws
- (14) Flat washers
- (14) 13mm nuts
- (2) Bag bands
- (4) Steel rods
- (1) Leg (with cutout)
- (1) 8" Hose adapter
- (6) Long 6mm hex screws
- (6) Lock washers
- (4) 1 1/2" x 2" Mounting Brackets

# 4 Setup

## Optional Cyclone Twin Bag Collector Assembly

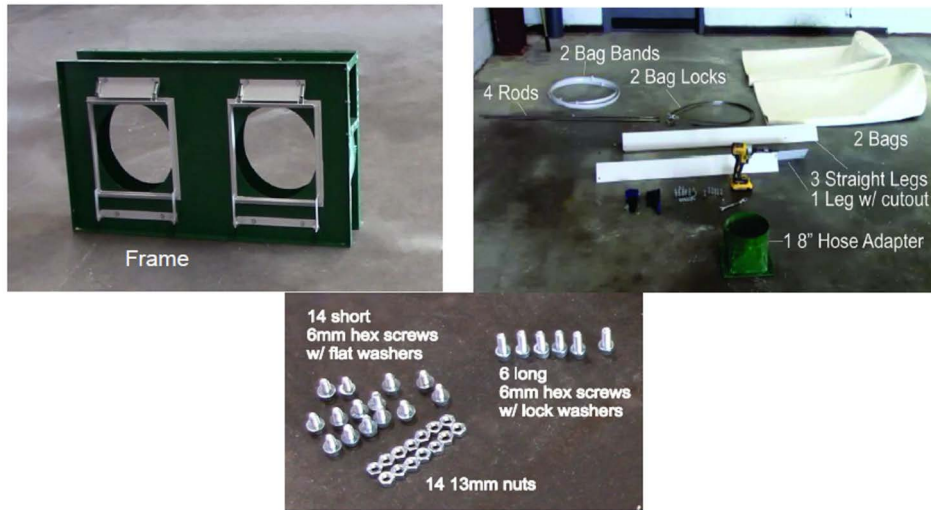

FIG. 4-2

2. Attach the hose adapter to the frame with 4 of the long screws with lock washers. Use the lower 4 holes.

**If utilizing collection bags, skip to Step 6 for leg installation.**

**If mounting the system to a chip collection container, continue with Step 3.**

3. Attach (4) mounting brackets to lower section of the bagging weldment with the short screws, flat washers and nuts.

**NOTE:** The short side of the bracket is mounted to the weldment, and the long side is mounted to the chip container. See Figure 4-3

4. Secure bracket to the chip container with fasteners not provided.
5. Proceed to Step 10

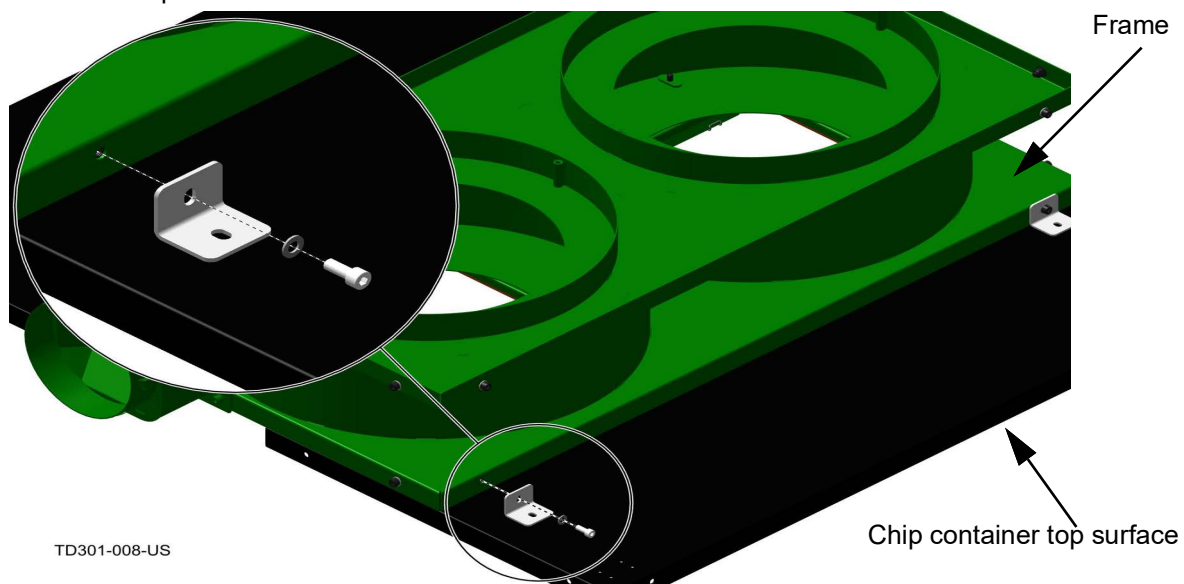

TD301-008-US

FIG. 4-3

6. Position the leg with the cutout on the corner by the hose adapter as shown below:



**FIG. 4-4**

7. Use short bolts with flat washers and nuts in top two leg holes as shown below:



**FIG. 4-5**

8. Finish tightening all six long screws with lockwashers in the hose adapter and the leg.
9. Proceed to Step 11.
10. Finish tightening all six long screws with lockwashers in the hose adapter.
11. Attach the remaining 3 legs with the short screws, flat washers and nuts.
12. Insert the rods into the bag bands as shown below:



**FIG. 4-6**

13. Place the bag bands with rods into the bags as shown below:



FIG. 4-7

14. Stand the frame and legs upright.
15. Place bag locks over the frame openings as shown below:



FIG. 4-8

16. Place the bags over the frame openings by inserting the rods into the mounting holes as shown above:
17. Tuck the bag between the frame openings and the bag locks.

18. Lock the bag locks by closing the latch, as shown below:



**FIG. 4-9**

19. Install the trash bags under the frame openings.
20. Swing the square trash bag bracket down by unclipping two latches holding the bracket.
21. Place the trash bag through the bracket as shown below:



**FIG. 4-10**

**NOTE:** Ensure that the trash bag full covers the bracket or leakage may occur.

## 4 Setup

### *Optional Cyclone Twin Bag Collector Assembly*

---

22. Refasten the trash bag clips to seal the trash bag to the frame, as shown below:



**FIG. 4-11**

23. Attach 8" hose to the inlet port with a standard hose clamp.  
Assembly complete.



## SECTION 5 OPERATION

### 5.1 General Use

Always be sure that all safety decals are clean and readable. Replace all damaged safety decals to prevent personal injury or damage to the equipment. Contact your local distributor, or call your Customer Service Representative to order more decals.

Always properly dispose of all by-products, including debris as wood shavings and dust, coolant and oil.

The chip extractor should only be used for removing sawdust and chips from the processing of wood.

Check your chip extractor as soon as you receive it. Report any transport damage to the transport company immediately.

Spare parts should be sourced through Wood-Mizer.

All electrical installation, service and/or maintenance should be performed by a qualified electrician.

### 5.2 Site Preparation



**WARNING!** Have a **qualified electrician** install the power to your machine. Failure to follow this may result in serious injury or death.



**CAUTION!** Improper voltage will cause damage to the motor and electronic components. Have a **qualified electrician** install the power supply to the Chip Extractor.



**IMPORTANT!** The power supply must meet the motor specifications concerning wire size, fused disconnect, and voltage, **which are provided in the motor's faceplate**. The electrical installation must also meet local codes.

### 5.3 Extractor Operation



**CAUTION!** Do not turn on extractor until the unit has been fully assembled. This includes inlet hoses or caps, as well as outlet hoses and collection systems. Failure to do so may result in damage to the machine.

1. Secure one end of flex hose to chip extractor inlets with hose clamps. Unused inlet ports must be blocked off. Failure to do so may result in machine damage and reduced airflow
2. Secure the other end of the flex hose to the unit producing chips.
3. Secure outlet hose to the outlet port with hose clamps. Outlet hose must go to either a chip collection system, chip container, or vent directly outside.
4. Start motor by pressing the green start button on the control box.
5. On units with multiple outlet ports, while the extractor is off and disconnected from power supply, adjust the inside baffle of the (optional bagging system) as needed to divert flow equally between the two outlet ports.

### 5.4 Collection System Operation



**CAUTION!** Before operation, ensure both the top filter bags and bottom collection bags are installed and secure. Replace any damaged filters or collection bags.

**NOTE:** Use only clean or lightly used filters. Dirty filters must be cleaned routinely for optimal airflow.

1. Connect outlet hose to collection system inlet with hose clamps.
2. Turn on extraction system.
3. Monitor the fill rate of the collection bags. If one bag is filling faster than the other one, turn the flow adjustment knob to even the flow rate.  
  
(show photo from CAD)
4. Once the collection bags reach  $\frac{3}{4}$  capacity, turn the extractor off and let all moving parts come to full rest. Remove the full collection bags and replace with empty ones.

## SECTION 6 TROUBLESHOOTING GUIDE

### 6.1 General Troubleshooting



**DANGER!** Disconnect power before clearing debris or **any other maintenance activity**. Failure to follow this will result in serious injury or death.

Follow the OSHA lockout procedures reprinted in the Safety section.

Keep hands away from the knives.

Do not operate the extractor without all covers and guards in place.

Problem	Possible Cause	Solution
<b>Inadequate chip collection or suction loss</b>	Increased static pressure or resistance	<ul style="list-style-type: none"> <li>• Clean or replace dirty filters.</li> <li>• Remove any sharp bends in hosing.</li> <li>• Keep bends larger than 45 degrees when possible.</li> <li>• Minimize hose length. Move extractor as close as possible to work piece.</li> </ul>
	Low airspeed	<ul style="list-style-type: none"> <li>• Block any unused inlet ports.</li> <li>• Use blast gates to increase suction in specific areas.</li> </ul>
	Leaks in system	Make sure all connections are airtight. Use silicone caulk or duct tape when necessary.
	Impeller spinning the wrong direction	Impeller should spin toward the outlet. Consult wiring diagram.
<b>Clogging</b>	Moisture content of wood	Use chip extractor with only dried lumber.
	Sharp bends in hosing	Keep bends under 45 degrees. Do not bend hose 90 degrees.
	Increased static pressure or resistance, low airspeed, or leaks in system	• See Solution for <b>Inadequate chip collection or suction loss</b> .
<b>Motor does not start</b>	No or inadequate power supplied to machine	Check circuit breaker. Check supply voltage. Consult electrician.
	Motor has overheated	See solution for <b>Motor has overheated</b> .
<b>The machine runs for a while but then stops</b>	Motor has overheated	See solution for <b>Motor has overheated</b> .

Problem	Possible Cause	Solution
<b>Motor has overheated</b>	Motor amperage too high and tripped overload protector	<ul style="list-style-type: none"> <li>• System running with little to no resistance. <b>Do not run the extractor without inlet and outlet hosing. Seal all unused ports.</b></li> <li>• Excessive chip volume. Reduce depth of cuts on workpiece.</li> </ul>
	Leaks in system	Check for leaks in hosing, body, and collection systems.
	Motor not properly wired	Check wiring diagram and consult electrician.
	Inadequate power supply. Supply voltage too low.	Consult electrician.

## 6.2 Extractor Optimization

- Extractors operate more efficiently when they are located closer to the unit.
- Minimize the length of hose runs to and from the extractor.
- Avoid sharp bends in hosing. Keep bends over 45 degrees whenever possible.
- If using a collection system, clean filters regularly. Replace any filters that are damaged or difficult to clean.
- Unused inlet ports must be blocked with included cap. Damaged caps should be replaced.
- Blast gates may be used to focus extraction power in certain areas.

## SECTION 7 GENERAL INFORMATION

### 7.1 How To Use The Parts List

- Use the table of contents to locate the assembly that contains the part you need.
- Go to the appropriate section and locate the part in the illustration.
- Use the number pointing to the part to locate the correct part number and description in the table.
- Parts shown indented under another part are included with that part.
- Parts marked with a diamond (◆) are only available in the assembly listed above the part.

See the sample table below.  
 Sample Part #A01111 includes part F02222-2 and subassembly A03333.  
 Subassembly A03333 includes part S04444-4 and subassembly K05555.  
*The diamond (◆) indicates that S04444-4 is not available except in subassembly A03333.*  
 Subassembly K05555 includes parts M06666 and F07777-77.  
*The diamond (◆) indicates M06666 is not available except in subassembly K05555.*

REF	PART #	DESCRIPTION	COMMENTS	QTY.
	A01111	<b>SAMPLE ASSEMBLY, COMPLETE (INCLUDES ALL INDENTED PARTS BELOW)</b>		1
1	F02222-22	Sample Part		1
	A03333	Sample Subassembly (Includes all indented parts below)		1
2	S04444-4	Sample Part (◆ Indicates part is only available with A03333)	Available in assemblies only.	1
	K05555	Sample Subassembly (Includes all indented parts below)		1
3	M06666	Sample Part (◆ Indicates part is only available with K05555)	Available in assemblies only.	2
4	F07777-77	Sample Part		1

#### To Order Parts:

- Use your online Customer Gateway Account to find and order parts.
- From the continental U.S., call **1-800-525-8100** to order parts. Have your customer number, serial number (VIN when applicable), and part numbers ready when you call.
- From international locations, contact the Wood-Mizer distributor in your area for parts.

## 7.2 Chip Extractor, 3kW 230v Single Phase, 3kW 230v Three-Phase

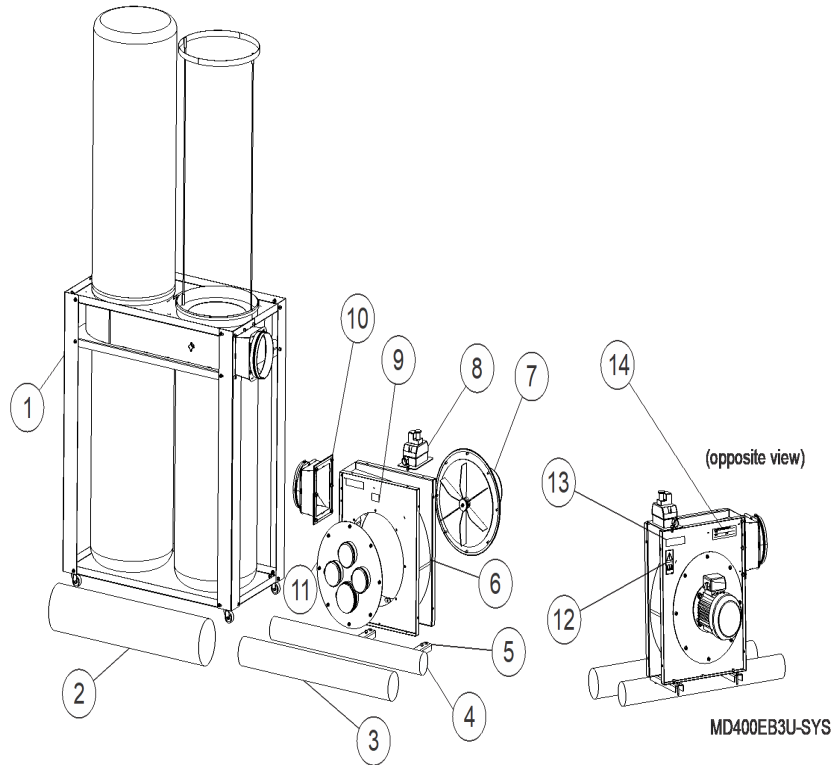

REF	PART #	DESCRIPTION	COMMENTS	QTY.
	MD400EA3U-SYS MD400EB3U-SYS	<b>CHIP EXTRACTOR, 3KW 230V 1PH COMPLETE</b> <b>CHIP EXTRACTOR, 3KW 230V 3PH COMPLETE</b>		1 1
1	301-008-US	2 Bag Dust Collection System w/Filter		1
2	116581	Dust Hose, 8" 10' PVC		1
3	116001	5" Duct Hose		1
4	116000	4" Duct Hose		1
5	537830-US	Assy, Mounting Feet		2
6	537835-US	Weldment, MD400 Frame		1
7	123361 123260	Assy, MD400 Motor/Fan Drive, 3kW, 1Ph (MD400EA3U) Assy, MD400 Motor/Fan Drive, 3kW, 3Ph (MD400EB3U)		1 1
8	123392 123393	Assy, Motor Starter, 1ph (MD400EA3U) Assy, Motor Starter, 3ph (MD400EB3U)		1 1
9	S20097	Decal, Motor Direction		1
10	537870-US	Assy, 8" Outlet		1
11	537853-US	Assy, 3x4", 1x5" Inlet		1
12	096317	Decal, Read Manual Before Operating		1
13	535402	Decal, Warning Pictograms		2
14	S20038	Plate, Multihead Name		1

### 7.3 Chip Extractor, 3kW 230v Three-Phase

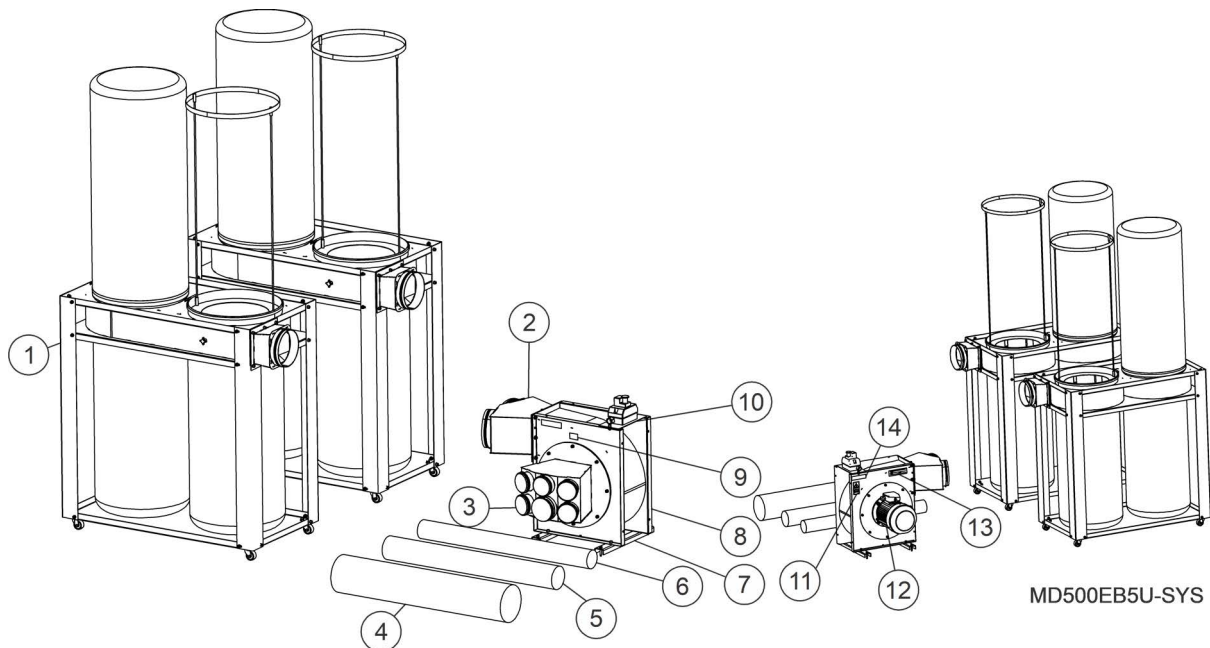

MD500EB5U-SYS

REF	PART #	DESCRIPTION	COMMENTS	QTY.
	MD500EB5U-SYS	CHIP EXTRACTOR, MD500 3PH COMPLETE SYS		1
1	301-008-US	2 Bag Dust Collection System w/Filter		2
2	310-501	Assy, 2x8" Outlet		1
3	310-010-US	Assy, 5x4" + 1x5" Inlet		1
4	116581	Dust Hose, 8" 10' PVC		2
5	116001	5" Duct Hose		1
6	116000	4" Duct Hose		1
7	537905-US	Assy, Mounting Feet		2
8	537874-US	Weldment, MD Frame		1
9	S20097	Decal, Motor Direction		1
10	123394	Assy, Motor Starter, 3ph		1
11	096317	Decal, Read Manual Before Operating		1
12	123264	Assy, MD500 Motor/Fan Drive		1
13	S20038	Plate, Multihead Name		1
14	535402	Decal, Warning Pictograms		2

## 7.4 Motor/Fan Drive, 3kW, Single-Phase

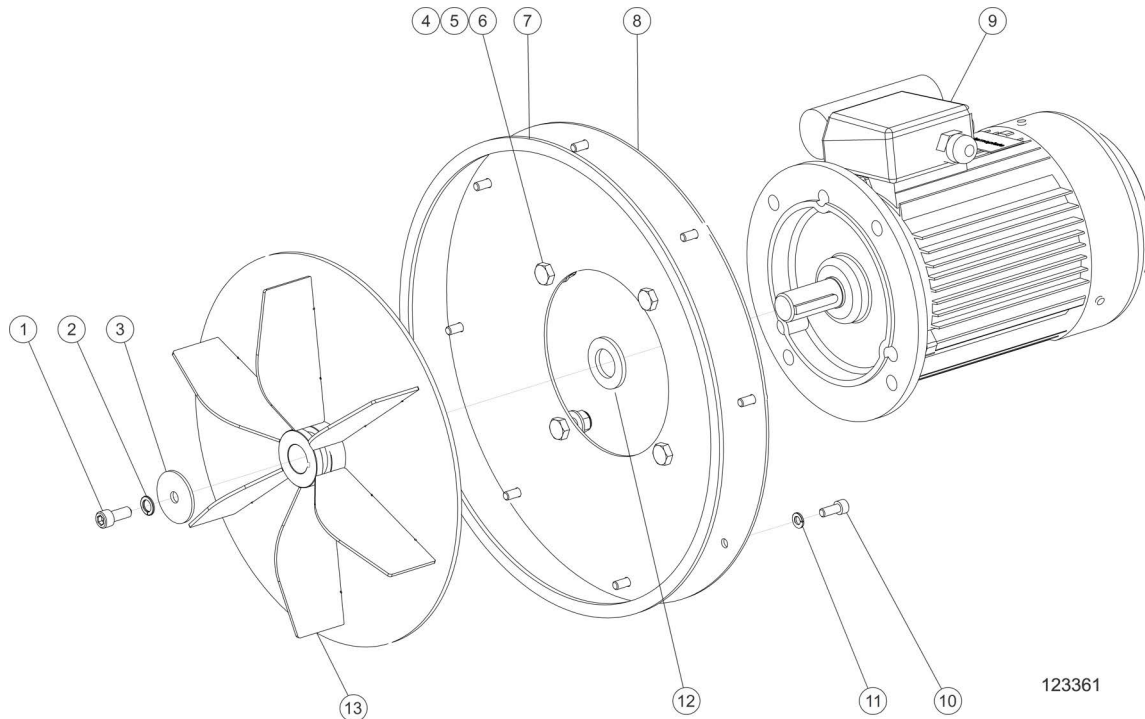

REF	PART #	DESCRIPTION	COMMENTS	QTY.
	123361	<b>ASSY, MD400 MOTOR/FAN DRIVE, 3KW, 1PH</b>		1
1	F05022-12	Bolt, M10-1.5x25 SHC		1
2	F05011-88	Washer, 10mm Split Lock		1
3	123395	Washer, .44IDx2.00ODx1/8		1
4	F05011-124	Washer, M12 Flat Zinc		4
5	F05010-209	Nut, M12x1.75 Hex Nylock Zinc		4
6	F05023-15	Bolt, M12-1.75 x 35mm 8.8 HH Zinc		4
7	537839-US	Gasket, Front Mount		1
8	537896-US	Plate, Motor Mount, 100/112 Frame		1
9	545708-UL	Motor, 100/2 3kW B5 60Hz		1
10	F05005-150	Bolt, M8x1.25x20mm SHCS		8
11	F05011-45	Washer, M8 Split Lock		8
12	123404	Washer, Spacer 1.12IDx1.97ODx.19		1
13	541540	Impeller, MD400-US, 28mm Bore		1



## 7.5 Motor/Fan Drive, 3kW, Three-Phase

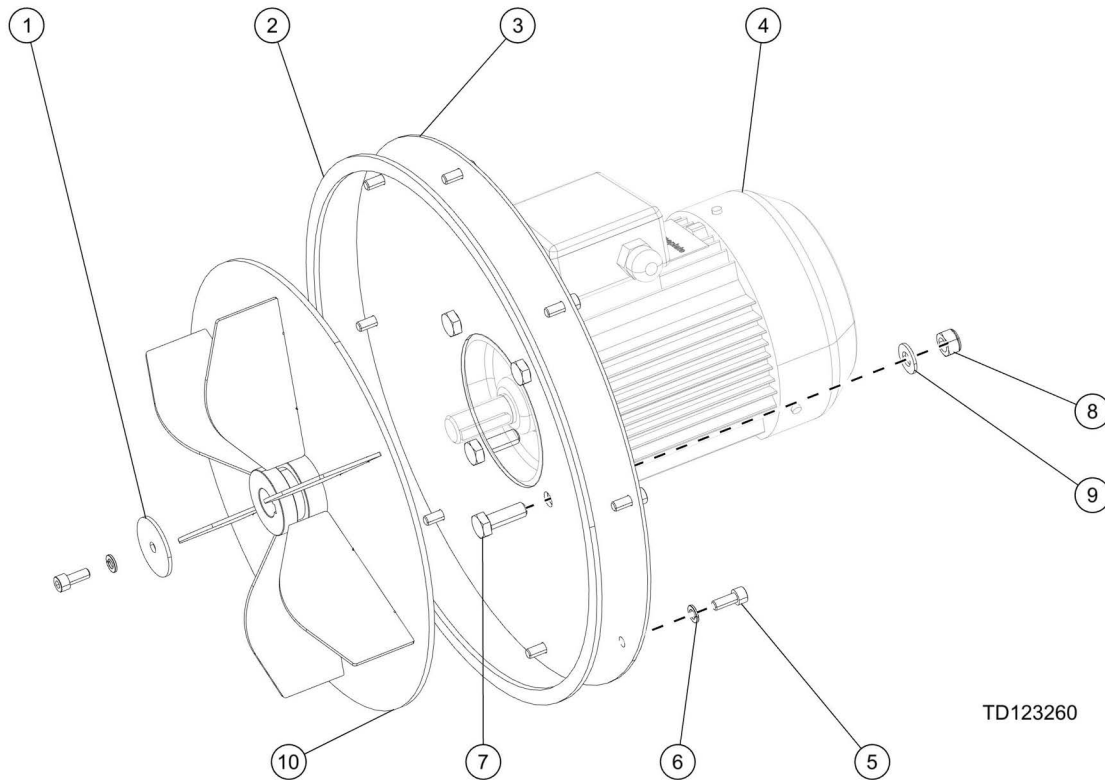

TD123260

REF	PART #	DESCRIPTION	COMMENTS	QTY.
	123260	<b>ASSY, MD400 MOTOR/FAN DRIVE, 3KW, 3PH</b>		1
1	123357	Washer, .35IDx2.00ODx1/8		1
2	537839-US	Gasket, Front Mount		1
3	537857-US	Plate, Motor Mount, 90 Frame		1
4	537859-UL	Motor, 3kW 3ph 3480RPM 230V 60Hz IMB5 UL		1
5	F05005-150	Bolt, M8x1.25x20mm SHCS		9
6	F05011-45	Washer, M8 Split Lock		9
7	F05023-15	Bolt, M12-1.75 x 35mm 8.8 HH Zinc		4
8	F05010-209	Nut, M12x1.75 Hex Nylock Zinc		4
9	F05011-124	Washer, M12 Flat Zinc		4
10	546720	Impeller, MD400 3ph 24mm Bore		1

## 7.6 Motor/Fan Drive, 5.5kW Three-Phase

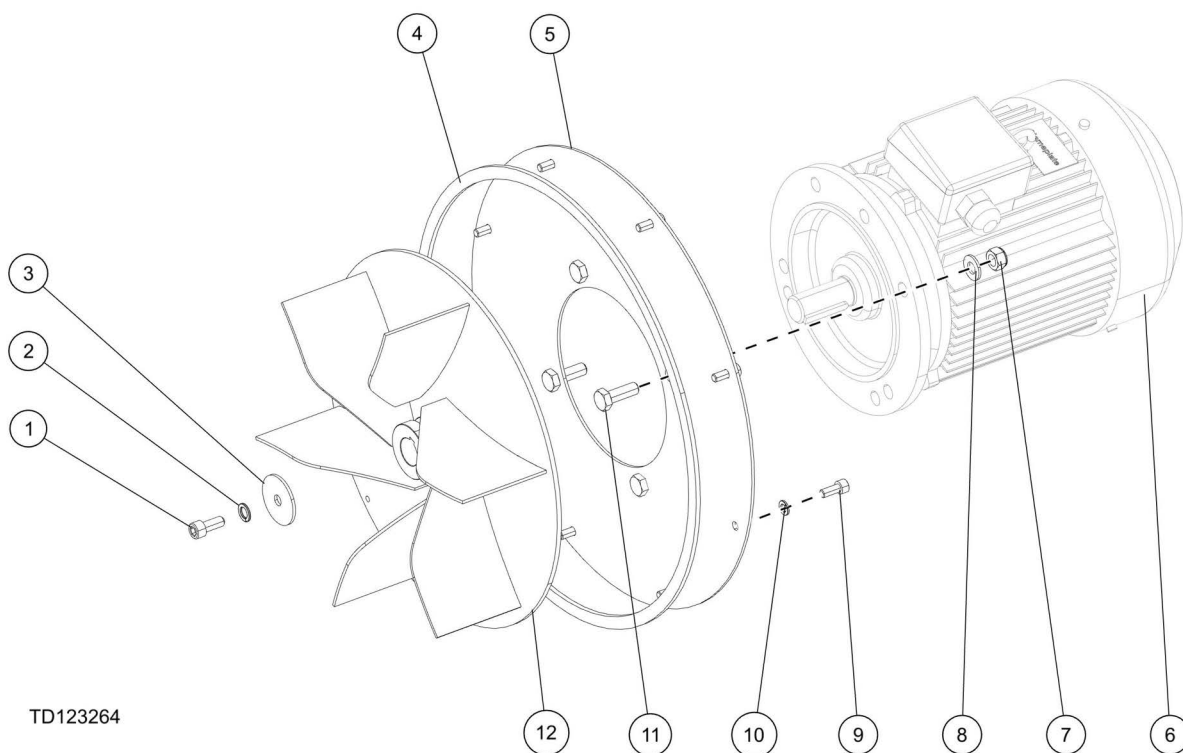

TD123264

REF	PART #	DESCRIPTION	COMMENTS	QTY.
	123264	<b>ASSY, MD500 MOTOR/FAN DRIVE</b>		1
1	F05022-12	Bolt, M10-1.5x25 SHC		1
2	F05011-88	Washer, 10mm Split Lock		1
3	123395	Washer, .44IDx2.00ODx1/8		1
4	537839-US	Gasket, Front Mount		1
5	537896-US	Plate, Motor Mount, 100/112 Frame		1
6	536933-UL 537897-UL	Motor, 5.5kW 3ph 3535 RPM 230V 60Hz IMB5 (MD500EB5U) Motor, 4kW, 3ph 3480 RPM, 60Hz, IMB5 (MD500EB4U)		1 1
7	F05010-209	Nut, M12x1.75 Hex Nylock Zinc		4
8	F05011-124	Washer, M12 Flat Zinc		4
9	F05005-150	Bolt, M8x1.25x20mm SHCS		8
10	F05011-45	Washer, M8 Split Lock		8
11	F05023-15	Bolt, M12-1.75 x 35mm 8.8 HH Zinc		4
12	541539	Impeller, MD500-UL		1

## 7.7 Motor Starter

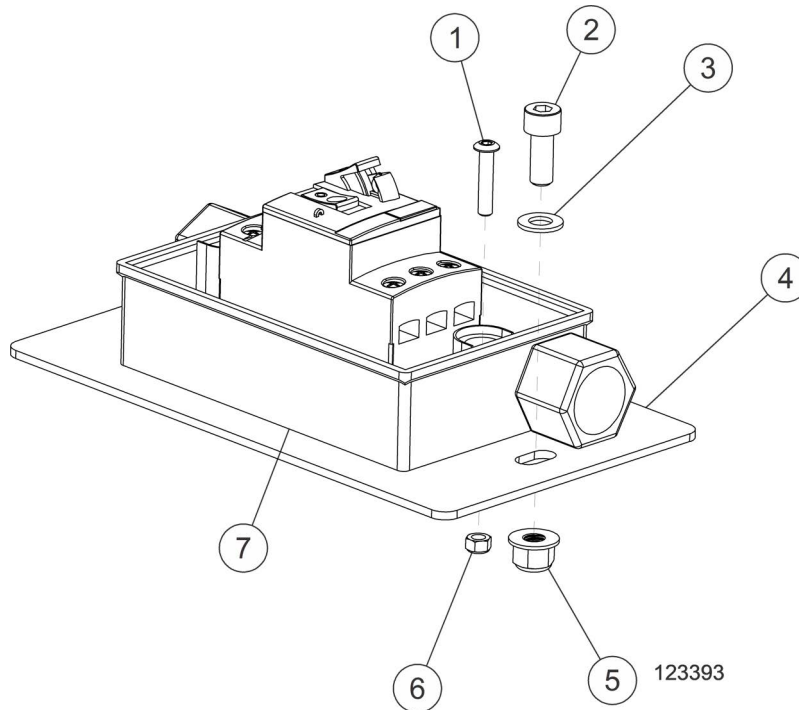

REF	PART #	DESCRIPTION	COMMENTS	QTY.
	123392	<b>ASSY, MOTOR STARTER, 1PH (MD400EA3U)</b>		1
	123393	<b>ASSY, MOTOR STARTER, 3PH (MD400EB3U)</b>		1
	123394	<b>ASSY, MOTOR STARTER, 3PH(MD500EB5U)</b>		1
1	F05020-38	Screw, M5-.8x25mm SHBC		2
2	F05005-150	Bolt, M8x1.25x20mm SHCS		2
3	F05026-4	Washer, M8 Flat		2
4	123292	Plate, Small Starter Box Mount (MD400EA3U, MD400EB3U)		1
	123355	Plate, Starter Box Mount, Large (MD500EB5U)		1
5	F05027-44	Nut, M8 x 1.25 Flanged Nylock		2
6	F05027-3	Nut, M5-.8 Class 8 Hex Nylock		2
7	121073	Assy, Motor Starter Box, 17-23A (MD400EA3U)		1
	121074	Assy, Motor Starter Box, 13-18A, 3Ph (MD400EB3U)		1
	121076	Assy, Motor Starter Box, 17-23A, 3Ph (MD500EB5U)		1
	052707	Motor Starter, Manual 17-23A Protector (MD400EA3U, MD500EB5U)		1
	052706	Motor Starter, Manual 13-18A Protector (MD400EB3U)		1
	068303	Cord Grip, M25 0.485-0.709" Black		1
	069399	Enclosure, GV2 Manual Motor Starter		1
	069400	E-Stop Button Kit, GV2		1
	121078	Cable Assy, MD400EA Motor (MD400EA3U)		1
	121079	Assy, Motor Cable, MD Series, 12AWG (MD400EB3U)		1
	121081	Assy, Motor Cable, MD Series, 10AWG, 3Ph (MD500EB5U)		1

## 7.8 3x4", 1x5" Inlet

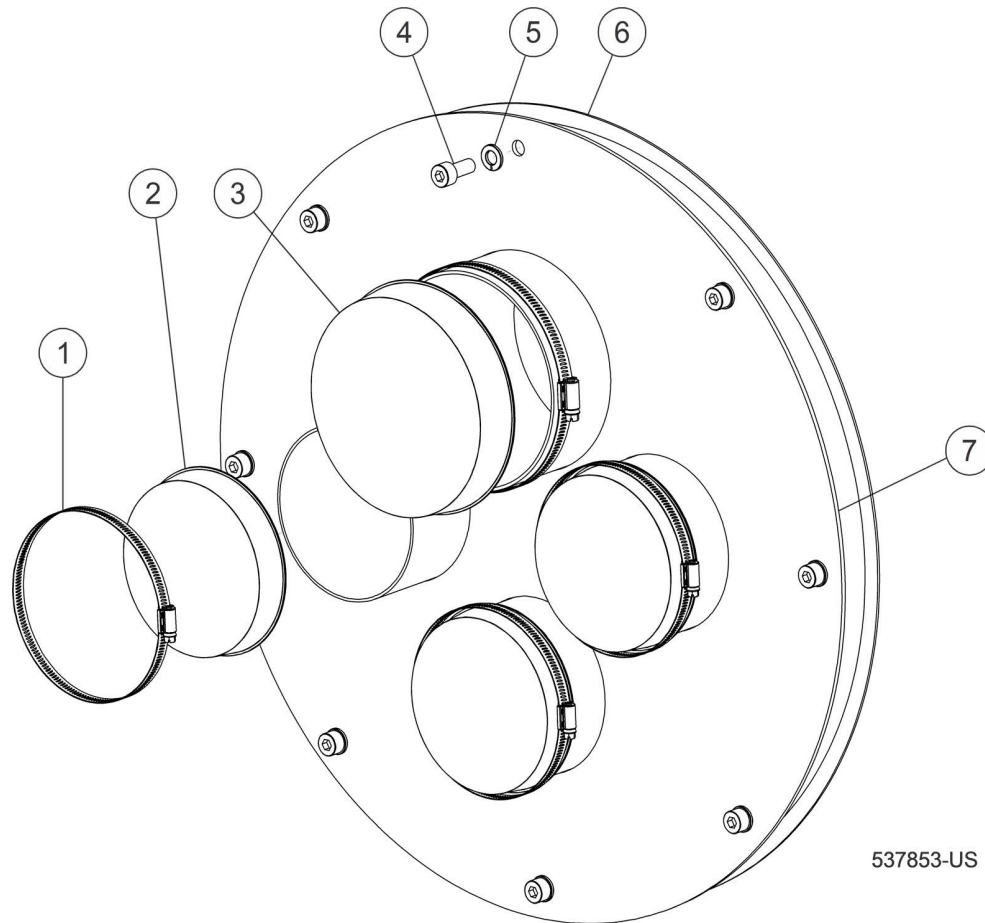

REF	PART #	DESCRIPTION	COMMENTS	QTY.
	537853-US	<b>ASSY, 3X4", 1X5" INLET</b>		1
1	123356	Clamp, Worm, 3 1/8 - 6 Dia		4
2	123295	Cap, 4" OD		3
3	123296	Cap, 5" OD		1
4	F05005-150	Bolt, M8x1.25x20mm SHCS		8
5	F05011-45	Washer, M8 Split Lock		8
6	537839-US	Gasket, Front Mount		1
7	537850-US	Weldment, 3x4", 1x5" Inlet		1

7.9 5x4" + 1x5" Inlet

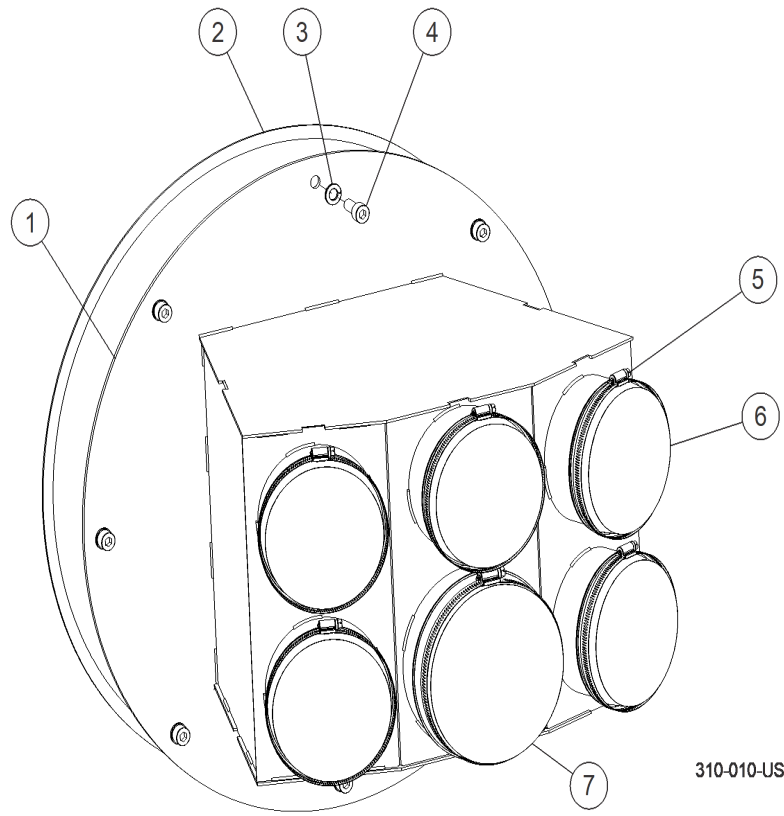

REF	PART #	DESCRIPTION	COMMENTS	QTY.
	310-010-US	<b>ASSY, 5X4" + 1X5" INLET</b>		1
1	537927-US	Weldment, 5x4", 1x5" Inlet		1
2	537839-US	Gasket, Front Mount		1
3	F05005-150	Bolt, M8x1.25x20mm SHCS		8
4	F05011-45	Washer, M8 Split Lock		8
5	123356	Clamp, Worm, 3 1/8 - 6 Dia		6
6	123295	Cap, 4" OD		5
7	123296	Cap, 5" OD		1

**7.10 10" Inlet**

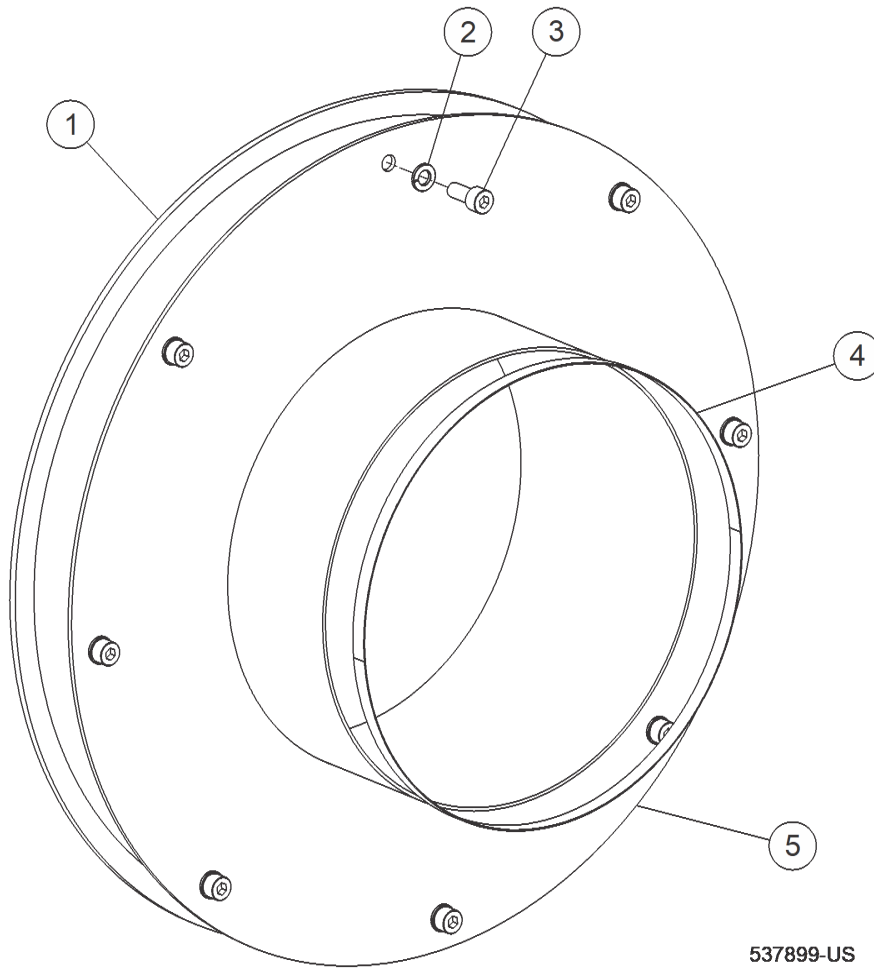

REF	PART #	DESCRIPTION	COMMENTS	QTY.
	537899-US	<b>ASSY, 10" INLET</b>		1
<b>1</b>	537839-US	Gasket, Front Mount		1
<b>2</b>	F05011-45	Washer, M8 Split Lock		8
<b>3</b>	F05005-150	Bolt, M8x1.25x20mm SHCS		8
<b>4</b>	123356	Clamp, Worm, 3 1/8 - 6 Dia		2
<b>5</b>	537230-US	Weldment, 10" Inlet		1

### 7.11 8" Outlet

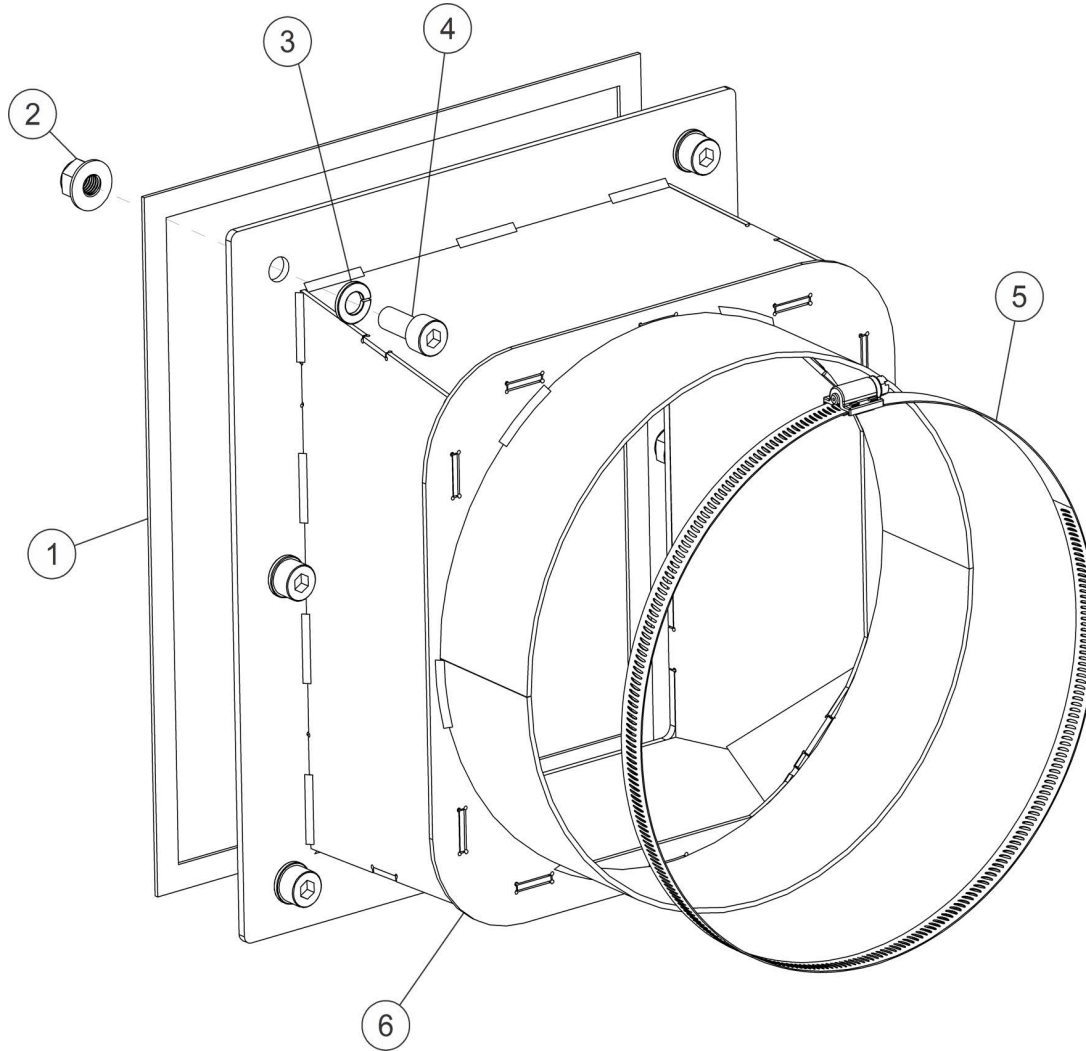

5370870-US

REF	PART #	DESCRIPTION	COMMENTS	QTY.
	537870-US	<b>ASSY, 8" OUTLET</b>		1
1	537846-US	Gasket, Small Outlet		1
2	F05027-44	Nut, M8 x 1.25 Flanged Nylock		6
3	F05011-45	Washer, M8 Split Lock		6
4	F05005-150	Bolt, M8x1.25x20mm SHCS		6
5	123378	Clamp, Worm, 7 1/8 - 10"		1
6	537869-US	Weldment, 8" Outlet		1

**7.12 2x8" Outlet**

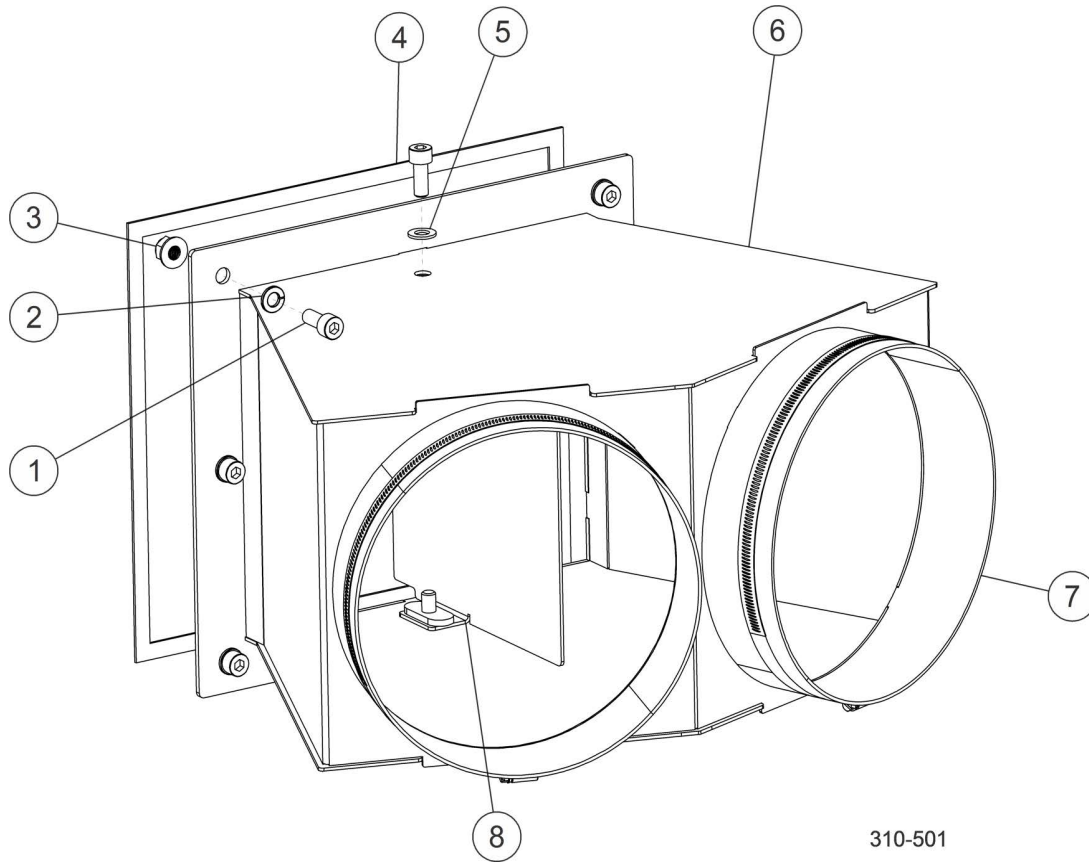

310-501

REF	PART #	DESCRIPTION	COMMENTS	QTY.
	310-501	<b>ASSY, 2X8" OUTLET</b>		1
1	F05005-150	Bolt, M8x1.25x20mm SHCS		8
2	F05011-45	Washer, M8 Split Lock		6
3	F05027-44	Nut, M8 x 1.25 Flanged Nylock		6
4	537891-US	Gasket, Outlet, Large		1
5	F05026-4	Washer, M8 Flat		2
6	537940-US	Weldment, 2x8" Outlet		1
7	123378	Clamp, Worm, 7 1/8 - 10"		2
8	537941-US	Weldment, Outlet Diverter Baffle		1



7.13 10" Outlet

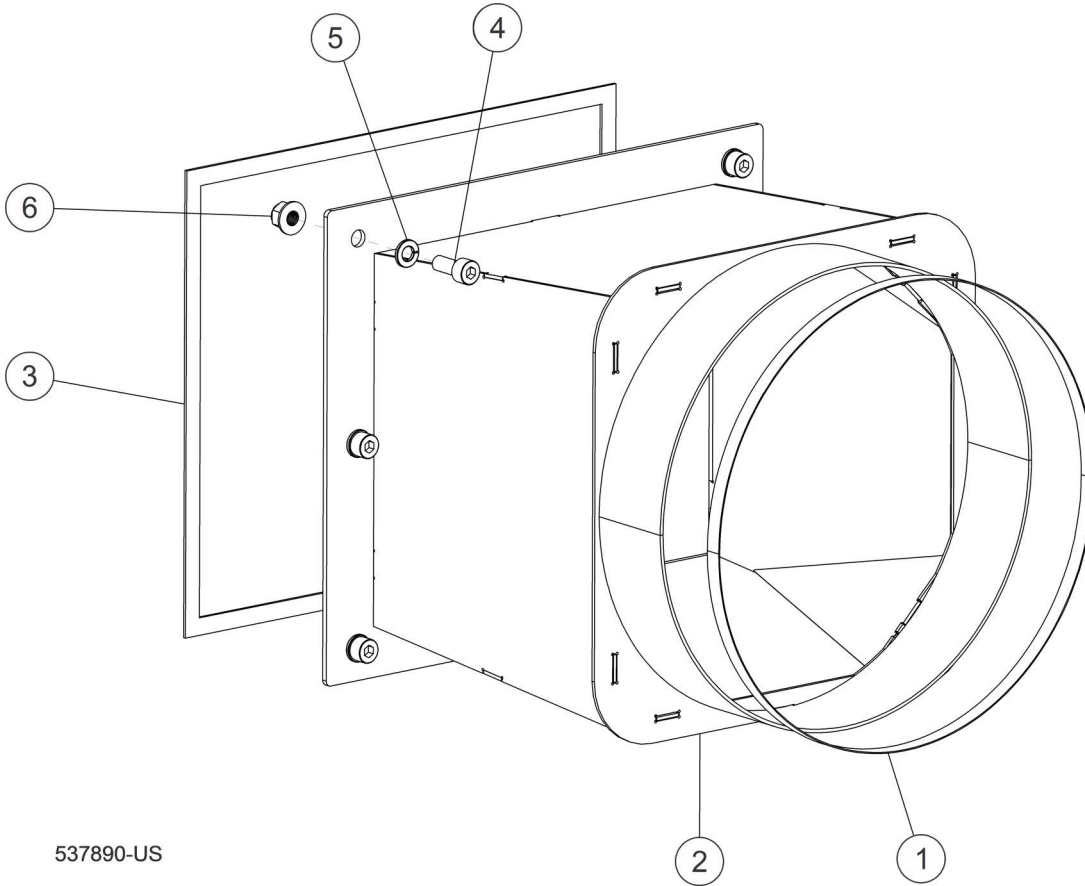

537890-US

REF	PART #	DESCRIPTION	COMMENTS	QTY.
	537890-US	<b>ASSY, 10" OUTLET</b>		1
1	123356	Clamp, Worm, 3 1/8 - 6 Dia		2
2	537889-US	Weldment, 10" Outlet		1
3	537891-US	Gasket, Outlet, Large		1
4	F05005-150	Bolt, M8x1.25x20mm SHCS		6
5	F05011-45	Washer, M8 Split Lock		6
6	F05027-44	Nut, M8 x 1.25 Flanged Nylock		6

## 7.14 Mounting Feet

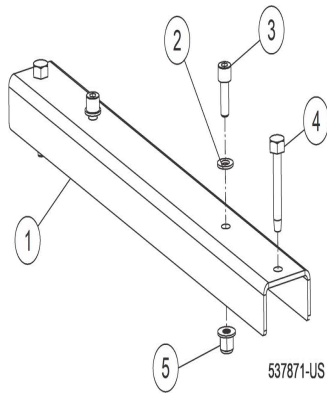

REF	PART #	DESCRIPTION	COMMENTS	QTY.
	537905-US	<b>ASSY, MOUNTING FEET</b>		2
	537830-US	<b>ASSY, MOUNTING FEET</b>		2
<b>1</b>	537871-US	Bracket, Large Stand (537905-US only)		1
	537833-US	Bracket, Small Stand (537830-US only)		1
<b>2</b>	F05026-4	Washer, M8 Flat		2
<b>3</b>	F05005-150	Bolt, M8x1.25x20mm SHCS		2
<b>4</b>	F05006-31	Screw, 5/16x2 1/2 Hex Lag		2
<b>5</b>	F05027-44	Nut, M8 x 1.25 Flanged Nylock		2

### 7.15 Bagging System

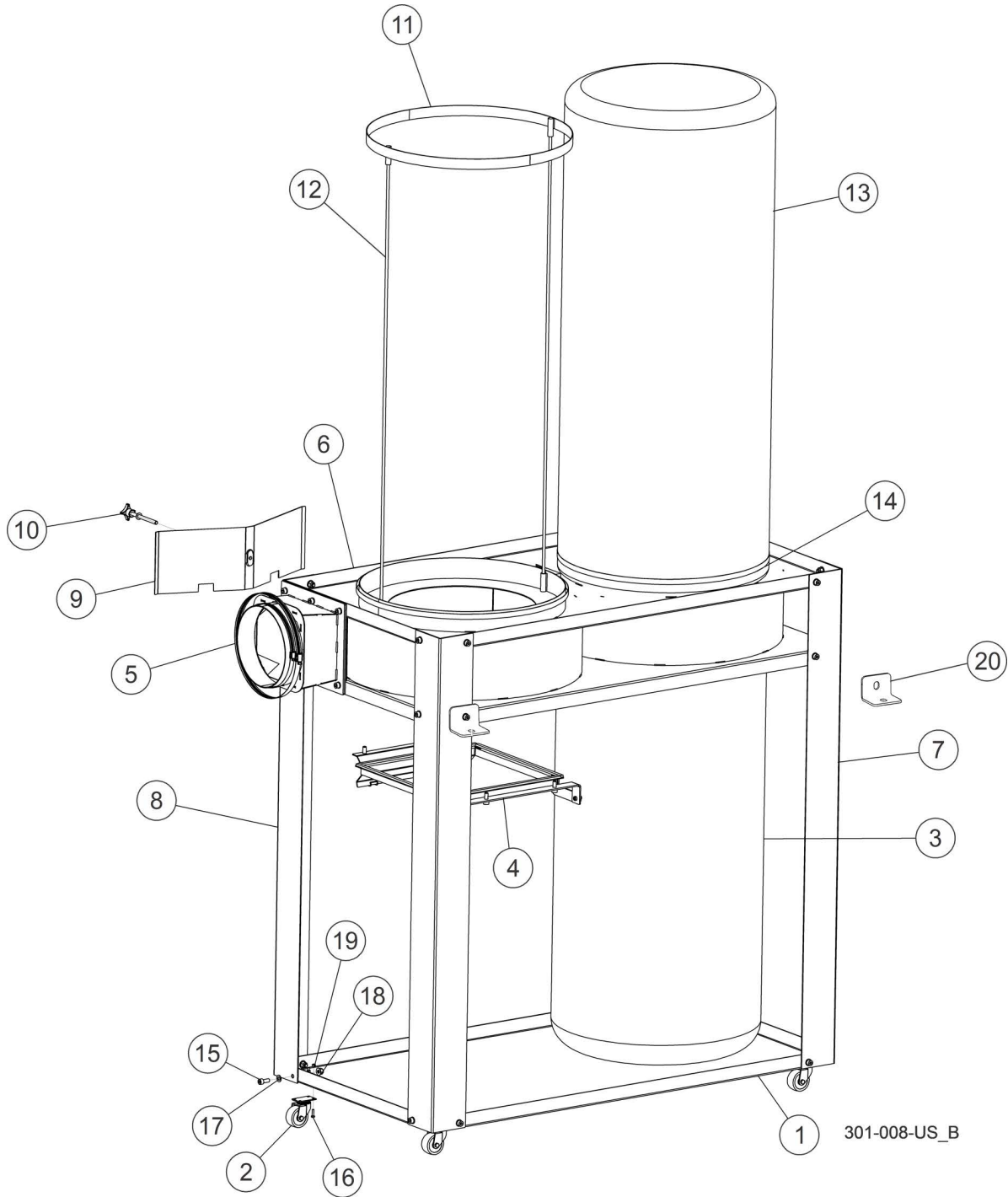

REF	PART #	DESCRIPTION	COMMENTS	QTY.
	301-008-US	<b>2 BAG DUST COLLECTION SYSTEM W/FILTER</b>		1
<b>1</b>	123297	Bracket, Top Table		1
<b>2</b>	123298	Caster, Swivel, 20Dx2 5/8 Height		4

**7** *General Information*  
*Bagging System*

REF	PART #	DESCRIPTION	COMMENTS	QTY.
3	123318	Collection Bag (65 Gallon)		2
4	123365	Assy, Bag Clamp		2
5	537870-US	Assy, 8" Outlet		1
6	537950-US	Weldment, Bagging		1
7	537972-US	Bracket, Leg		3
8	537973-US	Bracket, Leg		1
9	537974-US	Weldment, Flow Diverter		1
10	537977-US	Knob, M8		1
11	537980-US	Weldment, Filter Upright		2
12	537981-US	Rod, Filter Stand		4
13	537987	Filter Bag		2
14	537988	Clamp, 20 Dia Spring		2
15	F05005-150	Bolt, M8x1.25x20mm SHCS		22
16	F05020-10	Bolt, M4-.7 x 16 Class8 HH		16
17	F05026-4	Washer, M8 Flat		23
18	F05027-44	Nut, M8 x 1.25 Flanged Nylock		22
19	F05027-8	Nut, M4-.7 Class 8 Nylock		16
20	542341-US	Bracket, Chip Container Mount	542341-US added after 1/13/2022 per ECN 38300.	4

## 7.16 Bag Clamp

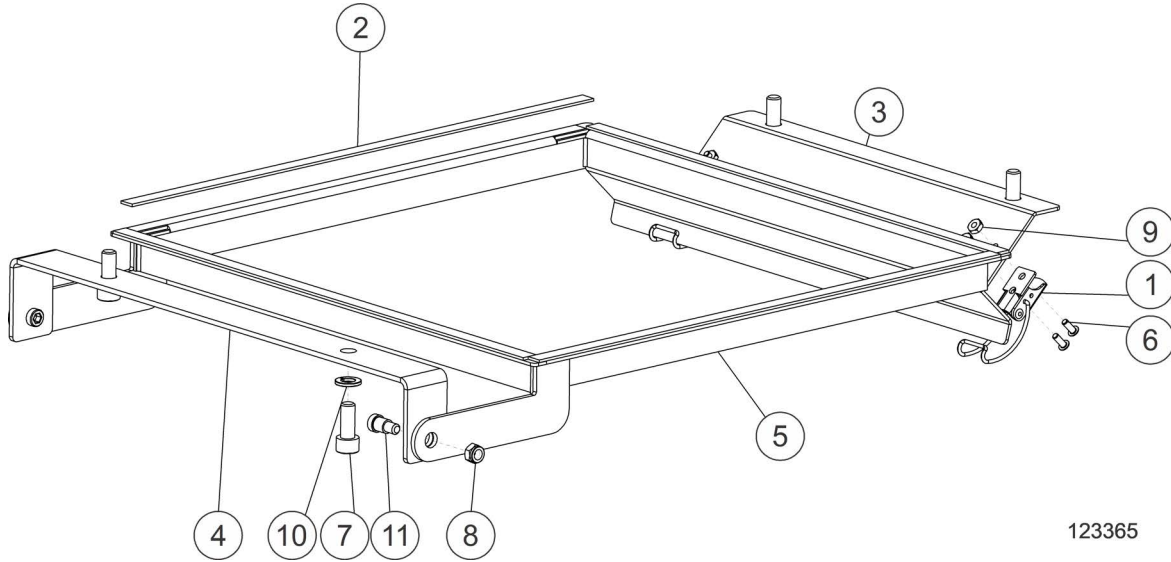

123365

REF	PART #	DESCRIPTION	COMMENTS	QTY.
	123365	<b>ASSY, BAG CLAMP</b>		1
1	123363	Latch, Draw		2
2	123366	Flat, Foam		4
3	537958-US	Bracket, Latch Mount		1
4	537961-US	Bracket, Bag Lock		1
5	537969-US	Weldment, Bag Clamp		1
6	F05004-65	Bolt, #6-32x3/8 Socket BH		4
7	F05005-150	Bolt, M8x1.25x20mm SHCS		4
8	F05010-200	Nut, M6-1.0 Nylon Lock		2
9	F05010-44	Nut, #6-32 Hex		4
10	F05011-45	Washer, M8 Split Lock		4
11	F05021-29	Bolt, M8x8mm SH Shoulder		2