

**Wood-Mizer® Moulder Planer
Parts Manual,**

MP360EB16U

rev. B1.00-B1.02

Safety is our #1 concern!

Form #2342-US



WARNING! Read and understand this manual before using this machine.

California

Proposition 65 Warning



WARNING: Breathing gas/diesel engine exhaust exposes you to chemicals known to the State of California to cause cancer and birth defects or other reproductive harm.

Always start and operate the engine in a well-ventilated area.
If in an enclosed area, vent the exhaust to the outside.
Do not modify or tamper with the exhaust system.
Do not idle the engine except as necessary.

For more information go to www.P65warnings.ca.gov.



WARNING: Drilling, sawing, sanding or machining wood products can expose you to wood dust, a substance known to the State of California to cause cancer. Avoid inhaling wood dust or use a dust mask or other safeguards for personal protection.

For more information go to www.P65Warnings.ca.gov/wood.

Active Patents assigned to Wood-Mizer, LLC

Wood-Mizer, LLC has received patents that protect our inventions which are a result of a dedication to research, innovation, development, and design. Learn more at: woodmizer.com/patents

©2024 Wood-Mizer LLC

Printed in the United States of America, all rights reserved. No part of this manual may be reproduced in any form by any photographic, electronic, mechanical or other means or used in any information storage and retrieval system without written permission from

Wood-Mizer, LLC
8180 West 10th Street
Indianapolis, Indiana 46214

SECTION 1 REPLACEMENT PARTS

1.1 How To Use The Parts List..... 1-1
 To Order Parts 1-1
 1.2 Sample Assembly..... 1-1
 1.3 Torque Values 1-2

SECTION 2 OVERVIEW

2.1 MP360 Components 2-1
 2.2 MP360 Additional Part Kit 2-2

SECTION 3 TABLES

3.1 Infeed Table 3-1
 3.2 Infeed Fence..... 3-2
 3.3 Guide Rails..... 3-3
 3.4 Outfeed Table..... 3-4
 3.5 Outfeed Fence 3-5

SECTION 4 OUTSIDE BODY

4.1 Outside Body Frame 4-1
 4.2 Top Cover 4-2
 4.3 Left Guard 4-4
 4.4 Right Guard 4-5
 4.5 Moving Plate 4-6
 4.6 Table MP360 4-7
 4.7 Left and Right Spindle Assembly 4-8
 4.8 Lower Cutterhead 4-9
 4.9 Movable Cutter Fence 4-10
 4.10 Clamp Rollers 4-11
 4.11 Pressure Roller..... 4-12
 4.12 Table Sawdust Collection 4-13
 4.13 Movable Side Cutter 4-14

SECTION 5 INSIDE BODY

5.1 Rods and Feed Assembly..... 5-1
 5.2 Drive Shaft Assemblies 5-2
 5.3 Up/Down Limiter 5-3
 5.4 Up/Down Feed System 5-4
 5.5 Upper Cutterhead 5-6
 5.6 Guard Set 5-7
 5.7 Inside Body Frame 5-8

SECTION 6 MOTOR KITS

6.1 Motor Kit 6-1
 6.2 Feed Motor Assembly 6-2
 6.3 Upper Cutter Motor Assembly..... 6-3
 6.4 Side Cutter Motor Assemblies 6-4
 6.5 Bottom Cutter Motor Assembly..... 6-5

Table of Contents

Section-Page

6.6 Safety Switches6-6
6.7 Electrical Box Mount6-7
6.8 Electrical Box Mount (rev B1.00)6-8
6.9 Electrical Control Panel.....6-9
6.10 Insert Panel (rev A1.00)6-10
6.11 Control Box (rev B1.00)6-12

SECTION 7 DECALS

7.1 Decals MP3607-1

SECTION 1 REPLACEMENT PARTS

1.1 How To Use The Parts List

- Use the table of contents to locate the assembly that contains the part you need.
- Go to the appropriate section and locate the part in the illustration.
- Use the number pointing to the part to locate the correct part number and description in the table.
- Parts shown indented under another part are included with that part.

To Order Parts

- From the continental US, call **1-800-525-8100** to order parts. Have your customer number, vehicle identification number, and part numbers ready when you call.
- From other international locations, contact the Wood-Mizer distributor in your area for parts.

1.2 Sample Assembly



REF	PART #	DESCRIPTION	COMMENTS	QTY.
	012345	SAMPLE ASSEMBLY, COMPLETE	INCLUDES ITEMS 1-6	1
1	F02222-22	Sample Part		1
2	F03333-33	Sample Part		2
	098765	Sample Subassembly	Includes items 3-6	1
3	S04444-44	Subassembly Sample Part		1
4	K55555	Subassembly Sample Part		1
	054321	Sample Sub-Subassembly	Includes items 5-6	2
5	022222	Sub-Subassembly Sample Part		1
6	F10234-56	Sub-Subassembly Sample Part		1

The Sample Assembly, Complete, part number 02345 (top level assembly) includes two parts (F0222-22 and F0333-33) and the 098765 subassembly.

Subassembly 098765 contains two parts(S04444-44 and K55555) and two copies of sub-subassembly 054321.

Each sub-subassembly 054321 contains two parts (022222 and F10234-56).

1.3 Torque Values

Grade		Units	SAE 5	SAE 8
Grade Mark				
Bolt Dia.	Threads. Per In.	Units	SAE 5	SAE 8
6	32	in-lbs (Nm)	20 (2.3)	-
8	32	in-lbs (Nm)	24 (2.7)	30 (3.4)
10	24	in-lbs (Nm)	35 (4.0)	45 (5.1)
10	32	in-lbs (Nm)	40 (4.5)	50 (5.7)
12	24	in-lbs (Nm)	50 (5.7)	65 (7.3)
1/4	20	in-lbs (Nm)	95 (10.7)	125 (14.1)
1/4	28	in-lbs (Nm)	95 (10.7)	150 (17.0)
5/16	18	ft-lbs (Nm)	17 (22.6)	23 (31.2)
5/16	24	ft-lbs (Nm)	20 (27.1)	25 (33.8)
3/8	16	ft-lbs (Nm)	30 (40.7)	40 (54.2)
3/8	24	ft-lbs (Nm)	35 (47.5)	45 (61.0)
7/16	14	ft-lbs (Nm)	50 (67.8)	65 (88.1)
7/16	20	ft-lbs (Nm)	55 (74.6)	70 (94.9)
1/2	13	ft-lbs (Nm)	75 (101.7)	100 (135.6)
1/2	20	ft-lbs (Nm)	85 (115.3)	110 (149.2)
9/16	12	ft-lbs (Nm)	105 (142.4)	135 (183.1)
9/16	18	ft-lbs (Nm)	115 (155.9)	150 (203.4)
5/8	11	ft-lbs (Nm)	150 (203.4)	195 (264.4)
5/8	18	ft-lbs (Nm)	160 (217.0)	210 (284.8)
3/4	10	ft-lbs (Nm)	170 (230.5)	220 (298.3)
3/4	16	ft-lbs (Nm)	175 (237.3)	225 (305.1)
7/8	9	ft-lbs (Nm)	302 (409.5)	473 (640.9)
7/8	14	ft-lbs (Nm)	300 (406.8)	400 (542.4)
1	8	ft-lbs (Nm)	466 (631.8)	714 (967.4)

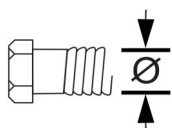

Metric Bolt Head Identification

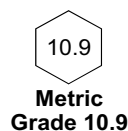
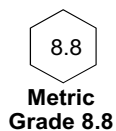

COARSE THREAD					FINE THREAD				Wrench Size	
Diameter & Thread Pitch	Metric 8.8		Metric 10.9		Diameter & Thread Pitch	Metric 8.8		Metric 10.9		
	N-m	lbs-ft	N-m	lbs-ft		N-m	lbs-ft	N-m		lbs-ft
6 x 1.0	8	6	11	8					10 mm	
8 x 1.25	20	15	27	20	8 x 1.0	21	16	29	22	13 mm
10 x 1.5	39	29	54	40	10 x 1.25	41	30	57	42	16 mm
12 x 1.75	68	50	94	70	12 x 1.25	75	55	103	76	18 mm
14 x 2.0	109	80	151	111	14 x 1.5	118	87	163	120	21 mm
16 x 2.0	169	125	234	173	16 x 1.5	181	133	250	184	24 mm
18 x 2.5	234	172	323	239	18 x 1.5	263	194	363	268	27 mm
20 x 2.5	330	244	457	337	20 x 1.5	367	270	507	374	30 mm
22 x 2.5	451	332	623	460	22 x 1.5	495	365	684	505	34 mm
24 x 3.0	571	421	790	583	24 x 2.0	623	459	861	635	36 mm
30 x 3.0	1175	867	1626	1199	30 x 2.0	1258	928	1740	1283	46 mm

SECTION 2 OVERVIEW

2.1 MP360 Components

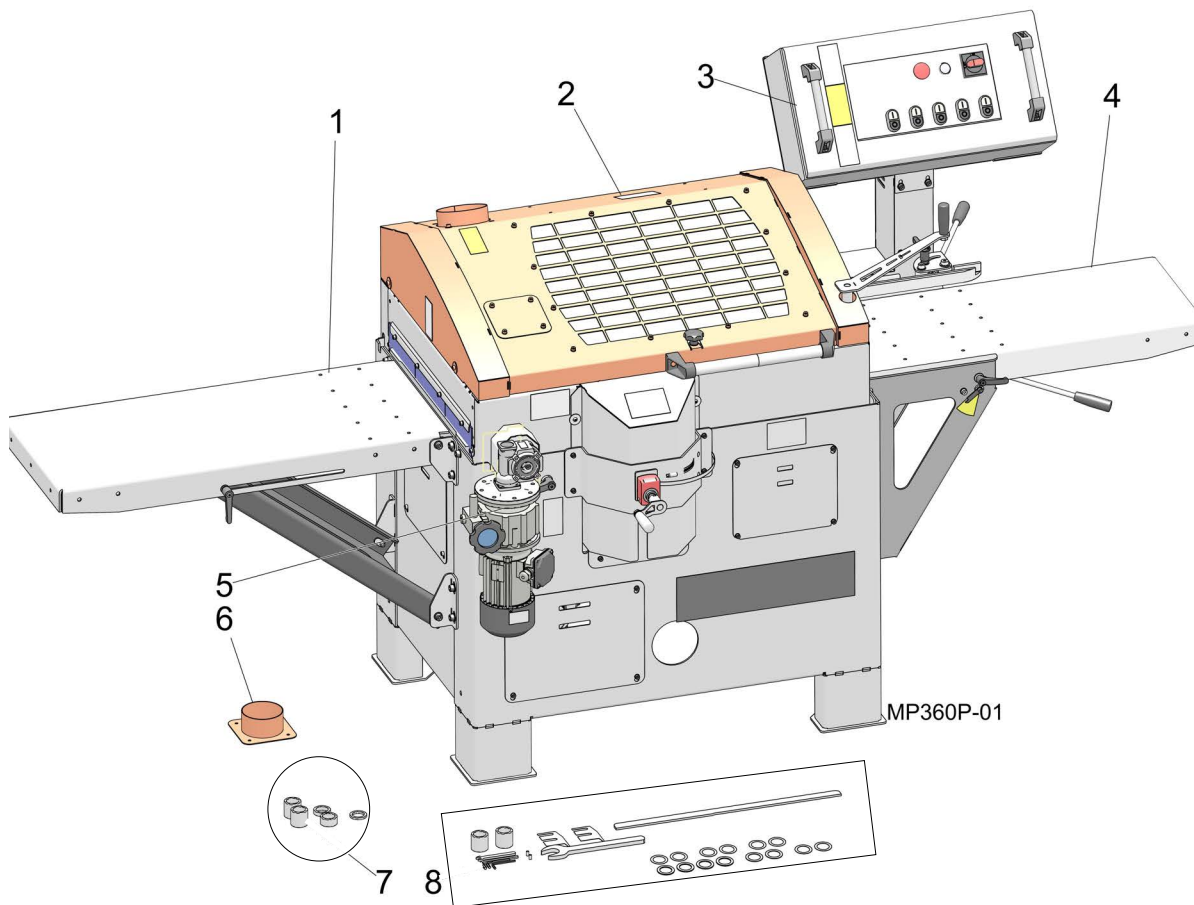

REF	PART #	DESCRIPTION	COMMENTS	QTY.
	MP360EB16U	MP360 4 SIDED MOULDER 230V 3P 60HZ W/VF		1
1	536974-US	Assembly, Outfeed Table Complete		1
2	535750-US	Assembly, MP360 Mechanical Assembly		1
3	532800-2U	Assembly, Electric Box MP360EB		
4	535800-US	Assembly, Infeed Table Complete		1
5	535745-2U-US	Assembly, Motor Kit MP360EB 3x230V		1
6	117625	Wldmnt, Extra Sawdust Outlet		1
7	117363	Kit, MP360 Bushing		1
8	537652-US	Assembly, MP360 Additional Part Kit	<i>(See Section 2.2)</i>	1
	536963	Assembly, Outfeed Fence (not shown)		1

2.2 MP360 Additional Part Kit

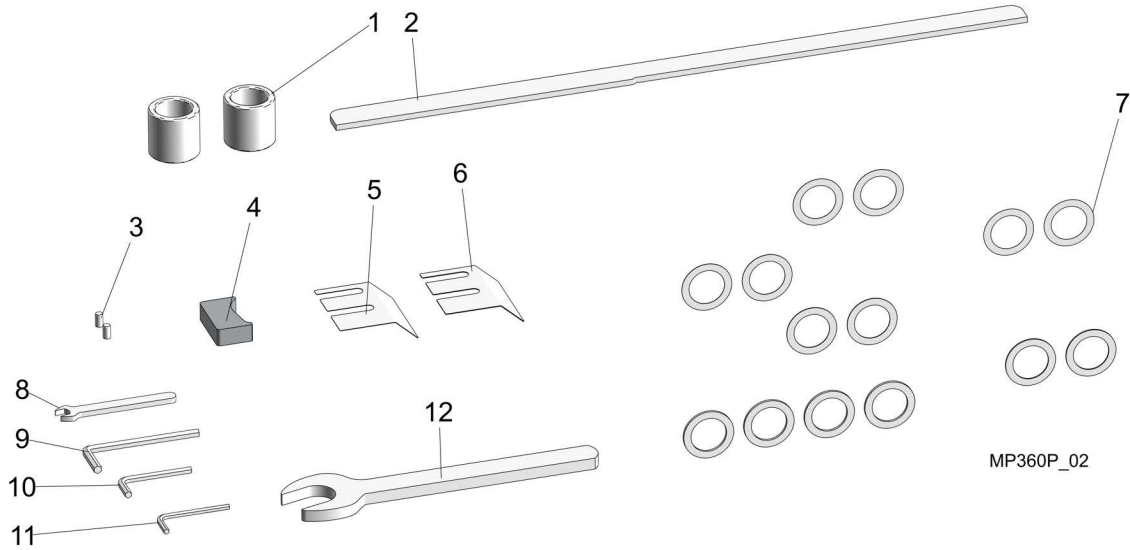

REF	PART #	DESCRIPTION	COMMENTS	QTY.
	537645-US	ASSEMBLY, MP260 ADDITIONAL PART KIT		1
1	533848-1-US	Bushing, 1-5/8ODx1.185IDx1.583		2
2	360-911	Bar, Fence Adjustment		1
3	F81048-13	Dowel Pin DIN7 6m6x12		2
4	537667	Tool, Knife Alignment		1
5	537648-US	Bracket, Cutter Guard		1
6	533502-US	Bracket, Cutter Guard		1
7	117361	Kit, MP Shims		1
	535185-US	MP160 Wrench Kit		1
8	535177-1-US	Wrench, 10mm Flat		1
9	535186-US	Wrench, 6mm Allen		1
10	092915-US	Wrench, 5mm Allen		1
11	093368-US	Wrench, 4mm Allen		1
12	537649-US	Wrench 30mm Flat DIN 894		1

SECTION 3 TABLES

3.1 Infeed Table

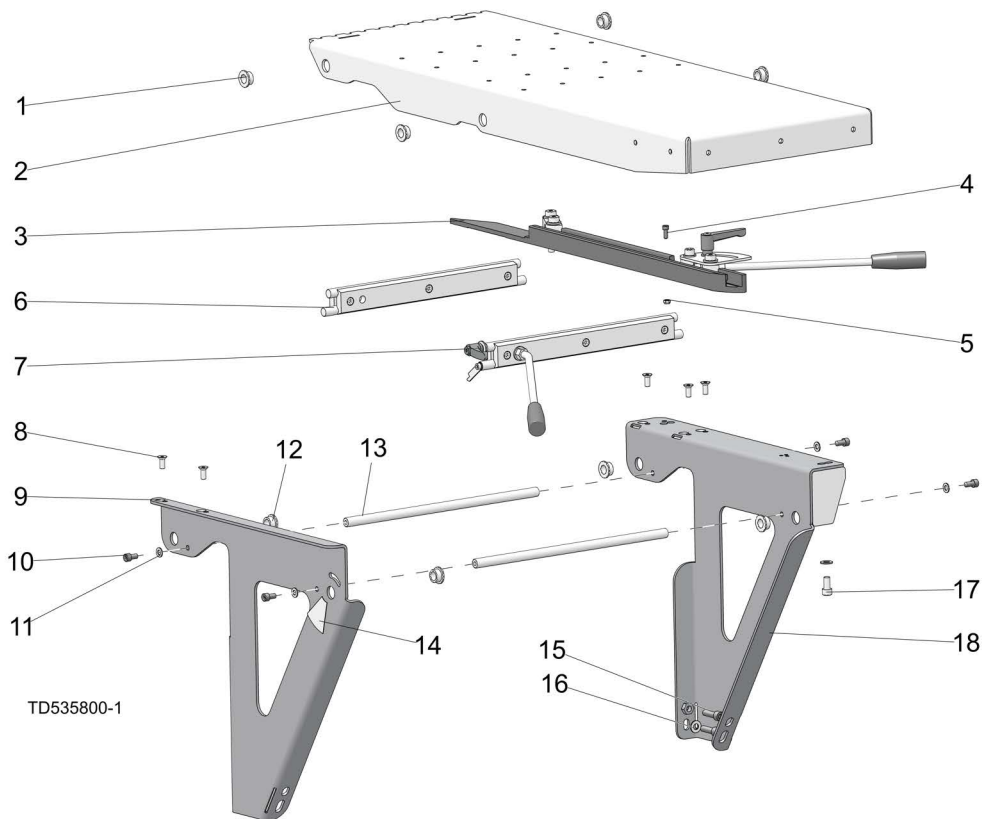

REF	PART #	DESCRIPTION	COMMENTS	QTY.
	535800-US	ASSEMBLY, INFEED TABLE COMPLETE		
	535755-US	Assembly, In-Feed Table Top		1
1	534359-US	Bushing, 0.59/0.86 -0.5 Flng 1.125-0.118		4
2	535754-1-US	Weldment, In-Feed Table Top		1
3	537516	Assembly, Infeed Fence (See Section 3.2)		1
4	F05004-206	Screw, M6-1.0 x 16mm SHCS		1
5	F05010-200	Nut, M6-1.0 Nylon Lock		1
6	535820	Assembly, Rear Guide Rail (See Section 3.3)		1
7	537505	Assembly, Front Guide Rail (See Section 3.3)		1
8	F05021-54	Bolt, M8-1.25x20 Flat SH C/S CL10.9		5
9	535764-1-US	Weldment, Left Table Bracket		1
10	F05021-10	Screw, M8-1.25x16 SHC		4
11	F05026-4	Washer, M8 Flat		4
12	534359-US	Bushing, 0.59/0.86 -0.5 Flng 1.125-0.118		4
13	535817-1-US	Round, 5/8x15 9/16 inch Rod		2
14	537504	Decal, Angular Scale		1
15	F05004-220	Bolt, M10-1.50x35mm Lg SCS		4
16	F05011-134	Washer, M10 Flat SAE		3
17	F05022-56	Bolt, M10-1.5x20 SHCS BO		1
18	535816-1-US	Weldment, Right Table Bracket		1

3.2 Infeed Fence

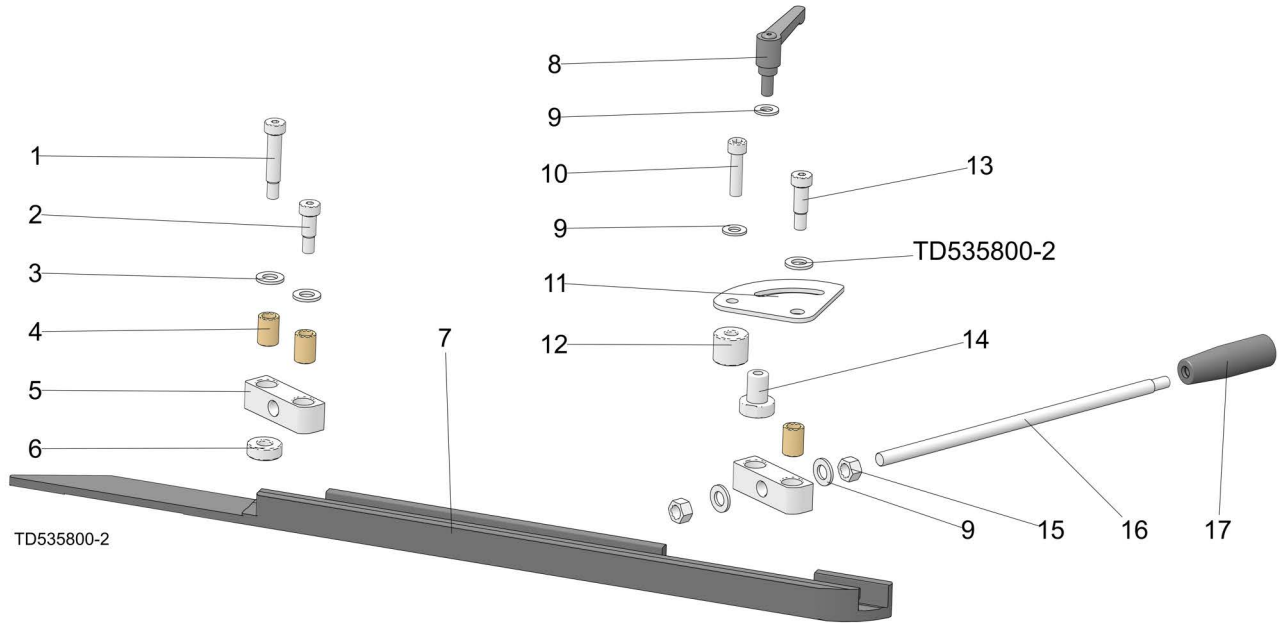

REF	PART #	DESCRIPTION	COMMENTS	QTY.
	537516	ASSEMBLY, INFEED FENCE		
1	F81003-152	Bolt 12/m10x45 Zc Shoulder 12.9 Din 9841 Iso 7379		1
2	F81003-68	Bolt, 12/m10x20 Shoulder 12.9 Din 9814 Iso 7379		1
3	F81056-1	Washer, M12 Flat Zinc		5
4	537508	Bushing 12/18-25		3
5	537506-1	Lever Block		2
6	537517-1	Bushing 12.5/30-11		1
7	537514-1	Fence 1		1
8	537518-US	Adjustable Lever Gn302-78-m10-20-sw		1
9	F81055-1	Washer, 10.5 Flat Zinc		2
10	F81003-22	Screw M10x40 Shcs Zc 8.8 Din 912 Iso 4762		1
11	537511-1	Plate		1
12	537513-1	Bushing 10.5/30-25		1
13	F81003-84	Bolt 12/m10x25 Zc Shoulder 12.9 Din 9841 Iso 7379		1
14	537512-1	Threaded Bushing		1
15	F81034-1	Nut, M12-8 Fe/zn5		2
16	537507-1	Threaded Rod		1
17	534381	Grip, K1202.11028 C Tapered		1

3.3 Guide Rails

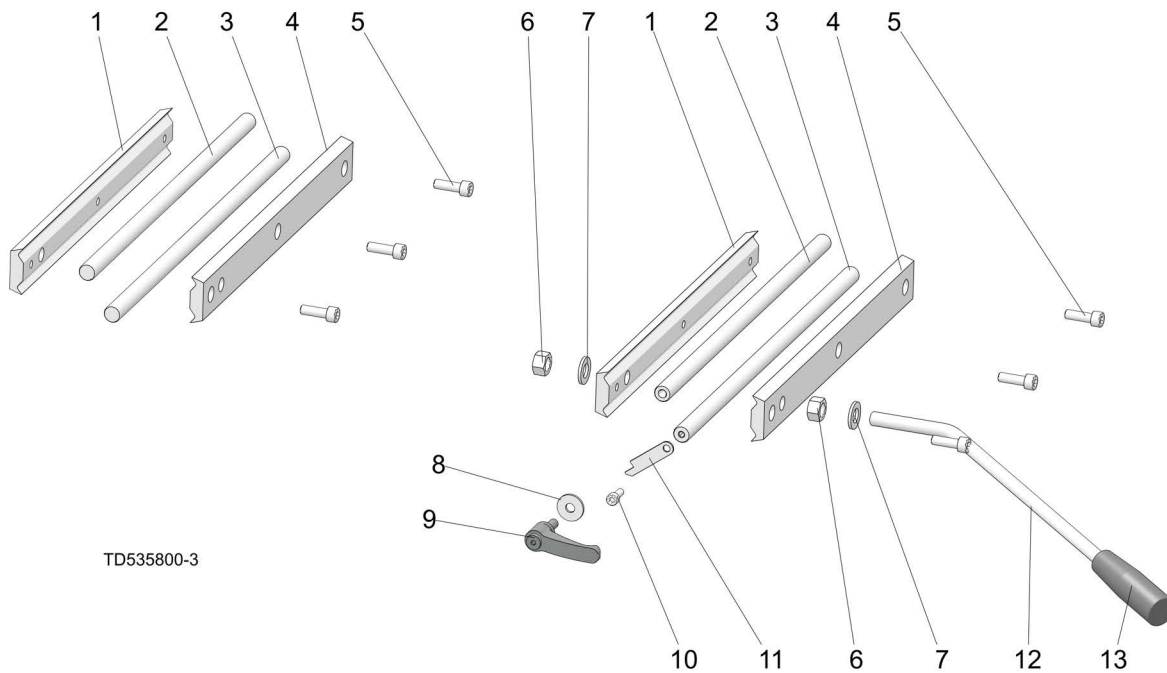

TD535800-3

REF	PART #	DESCRIPTION	COMMENTS	QTY.
-	535820	REAR ADJUSTMENT RAIL ASSEMBLY		1
1	537502	Left Bracket		1
2	535819	Rod 2		1
3	535818	Rod1		1
4	537501	Right Bracket		1
5	F81002-21	Screw M8x25 Shcs Zc 8.8 Din 912 Iso 4762		3
	537505	FRONT ADJUSTMENT RAIL ASSEMBLY		
1	537502	Left Bracket		1
2	535819	Rod 2		1
3	535818	Rod 1		1
4	537501	Right Bracket		1
5	F81002-21	Screw M8x25 Shcs Zc 8.8 Din 912 Iso 4762		3
6	F81034-1	Nut M12 Zc 8 Din 934		2
7	F81056-1	Washer 13 Zc Din 126 Iso 7091		2
8	F81054-11	Washer 8.5 Zc Fender Din 9021 Iso 7093		1
9	534378	Adjustable Handle Erz.63 P- M8x20		1
10	F81001-21	Screw M6x16 Shcs Zc 8.8 Din 912 Iso 4762		1
11	537503-1	Scale Indicator		1
12	534379-1	Rod, M12		1
13	534381	Grip, K1202.11028 Tapered		1

3.4 Outfeed Table

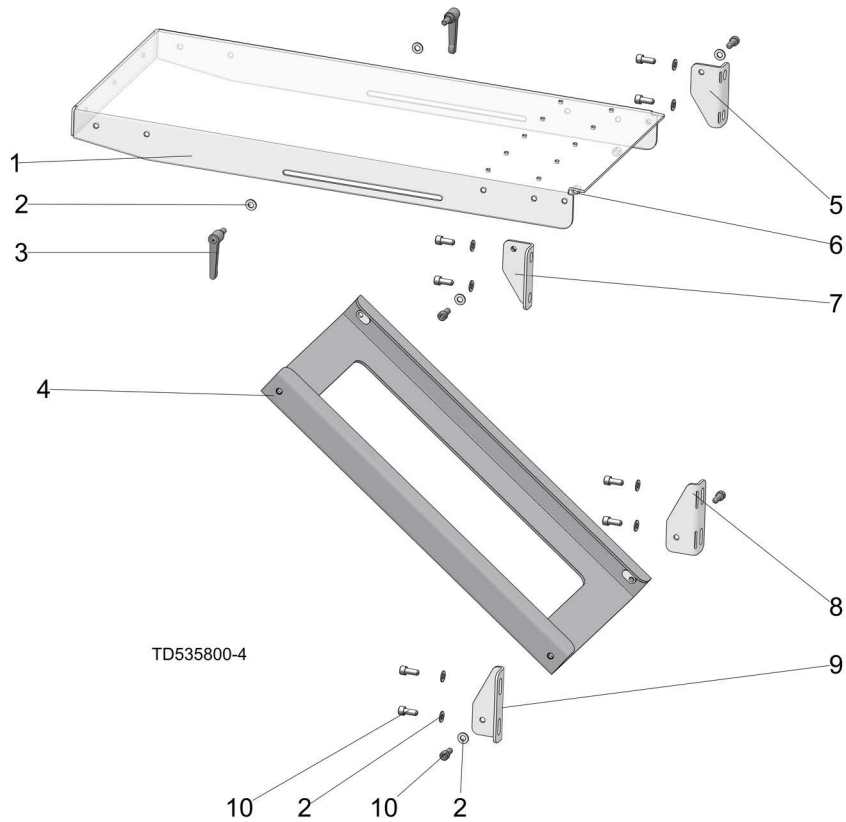

REF	PART #	DESCRIPTION	COMMENTS	QTY.
	536974-US	ASSEMBLY, OUTFEED TABLE COMPLETE		
1	536976-1-US	Bracket, Outfeed Table Top		1
2	F05011-134	Washer, M10 Flat SAE		16
3	537518-US	Lever, Adjustable GN302-78-M10-20-SW		2
4	536977-1-US	Weldment, Support Welded		1
5	536979-1-US	Bracket, Mounting Plate 4		1
6	F05004-270	Nut, M10-1.50 Hex Nyl Lock		2
7	536970-1-US	Bracket, Mounting Plate 2		1
8	536978-1-US	Bracket, Mounting Plate 3		1
9	536967-1-US	Bracket, Mounting Plate 1		1
10	F05022-12	Bolt, M10-1.5x25 SHC		12

3.5 Outfeed Fence

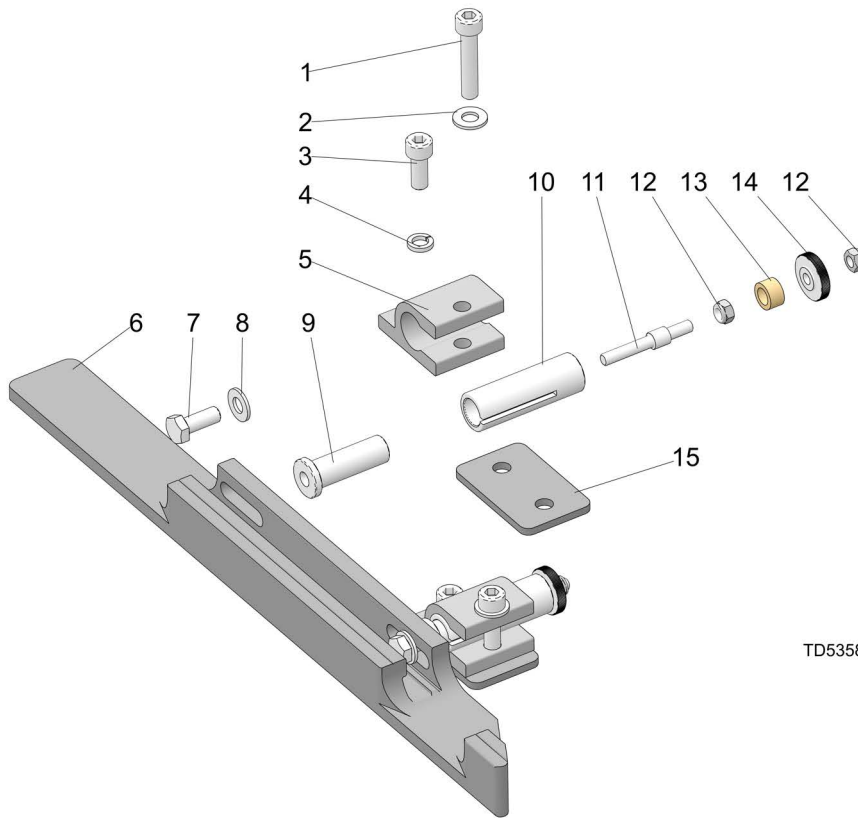

TD535800-5

REF	PART #	DESCRIPTION	COMMENTS	QTY.
	536963	ASSEMBLY, OUTFEED FENCE		
1	F81002-29	Screw M8x40 Shcs Zc 8.8 Din 912 Iso 4762		2
2	F81054-1	Washer 8.4 Zc Din 126 Iso 7091		2
3	F81002-30	Screw M8x20 Shcs Zc 8.8 Din 912 Iso 4762		2
4	F81054-4	Washer 8.2 Zc Spring Lock Din 127		2
5	536966-1	Clamp		2
6	536962-1	Fence 2		1
	536965	Adjustable Knob		2
7	F81002-4	Bolt M8x20 Hh Zc Ft 8.8 Din 933		1
8	F81054-1	Washer 8.4 Zc Din 126 Iso 7091		1
9	541455	Knob Pin		1
10	537001-1	Pin Guide		1
11	541455	Threaded Pin M6		1
12	F81031-2	Nut M6 Zc 8 Nylock Din 982 Iso 7040		2
13	537002	Insert		1
14	541454	Knurled Nut M6		1
15	536968-1	Base		2

SECTION 4 OUTSIDE BODY

4.1 Outside Body Frame

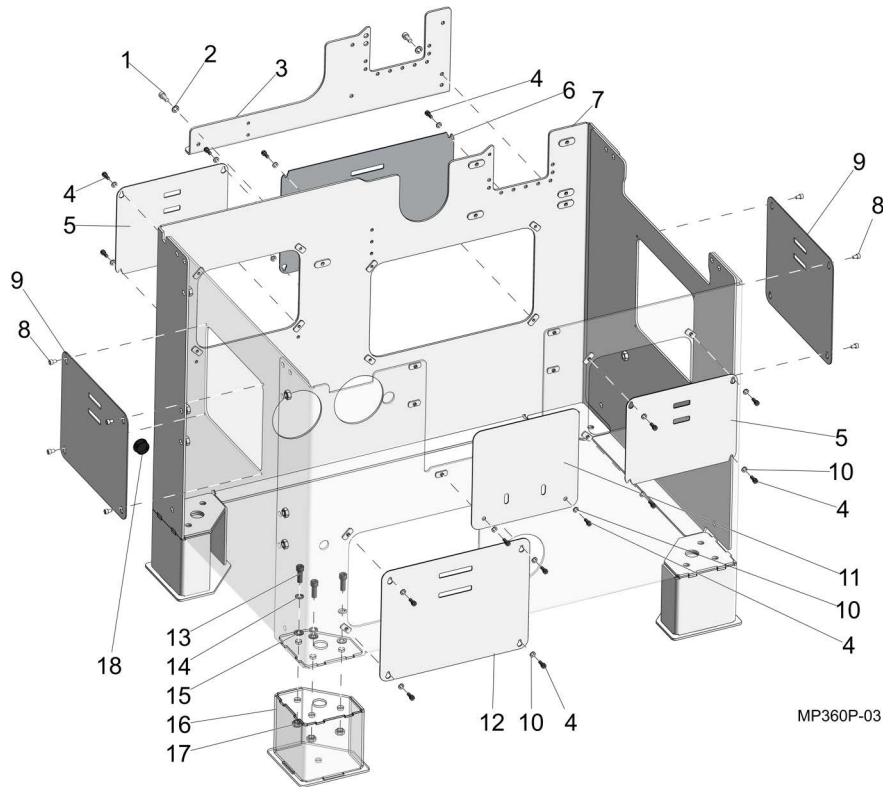

REF	PART #	DESCRIPTION	COMMENTS	QTY.
1	F05005-150	Bolt, M8x1.25x20mm SHCS		2
2	F05026-49	Washer, M8 Flat		2
3	535620-1-US	Bracket, Side Bracket		1
4	F05004-206	Bolt, M6-1.0x16mm SHCS		18
5	535642-1-US	Plate, Cover 2		1
6	535644-1-US	Plate, Cover 5		1
7	535615-1-US	Wldmnt, Outside Body		1
8	F05020-19	Screw, M6-1 x 10 SHC		8
9	535643-1-US	Plate, Cover3		2
10	F05026-15	Washer, M6 Flat Class 4		18
11	535645-1-US	Plate, Cover 4		1
12	535659-1-US	Plate, Cover 1		1
	535875-US	Assembly, Foot		4
13	F81003-110	Screw, M10-1.5x30mm SHCS		3
14	F05011-88	Washer, 10MM Split Lock		3
15	F05011-1343	Washer, M10 Flat		3
16	535622-US	Bracket, Foot Part 3		1
17	F05027-2	Nut, M10-1.5 Hex Weld		3

4.2 Top Cover

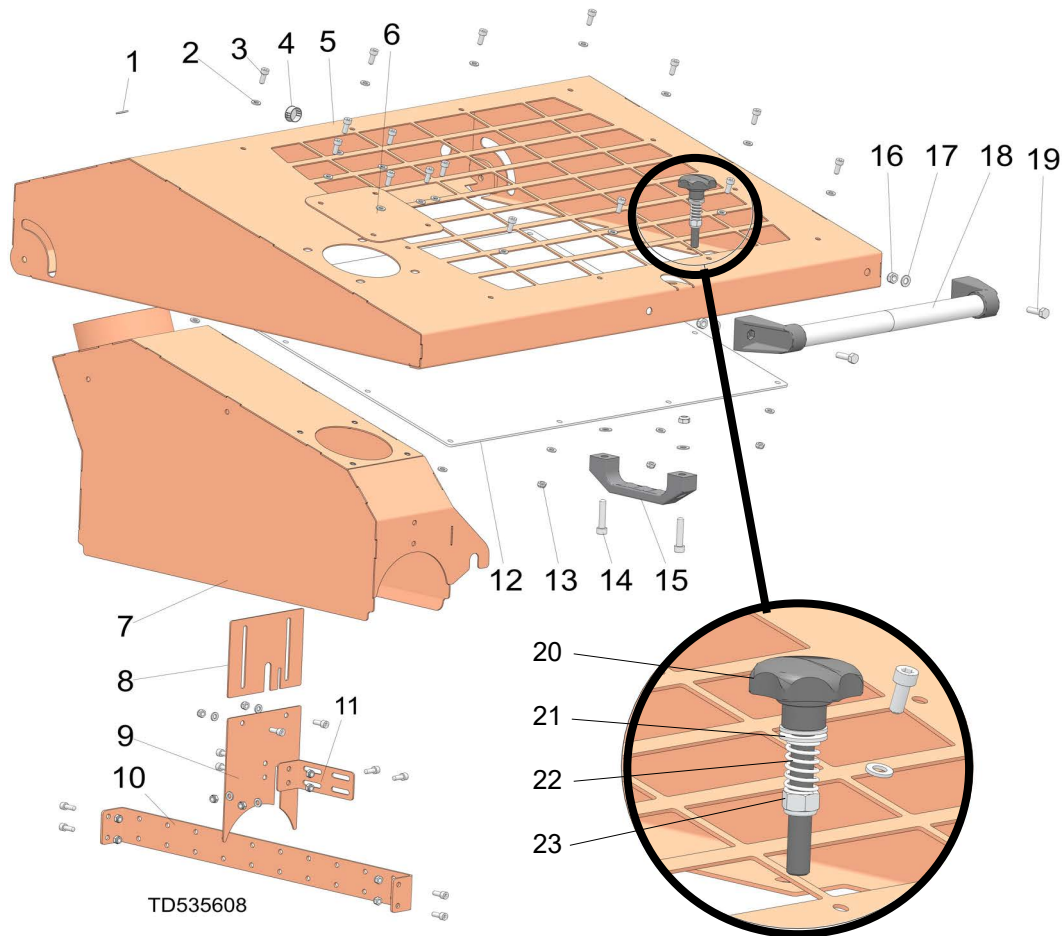

REF	PART #	DESCRIPTION	COMMENTS	QTY.
	536986-US	ASSEMBLY, TOP COVER		1
1	F05011-11	Washer, 1/4 SAE Flat		1
2	F05026-1	Washer, M6 Flat Class 4		32
3	F05004-206	Bolt, M6-1.0x16mm SHCS		27
4	086811-US	Plug, 13/16 Hole Plastic		1
5	535180-US	Wldmnt, Top Cover		1
6	535609-1-US	Plate, Cover Plate		1
7	535189-1-US	Wldmnt, Sawdust Outlet Weldment		
8	535610-1-US	Plate, Separator 1		1
9	535612-1-US	Plate, Separator 2		1
10	535193-1-US	Bracket, Mounting Angle		1
11	535611-1-US	Bracket, Separator Connector		1
12	535613-US	Plate, Inspection Window		1
13	F05010-200	Nut, M6-1.0 Nylon Lock		22
14	F05021-6	Screw, M8-1.25x40mm SHC		2
15	533506	Handle, Pull		1
16	F05010-132	Nut, M8-1.25 Hex Nylock		4

4**Outside Body***Top Cover*

REF	PART #	DESCRIPTION	COMMENTS	QTY.
17	F05026-4	Washer, M8 Flat		4
18	533506	Handle, Cover Pull		1
19	F05004-40	Bolt, M8x1.25x25 HH FT		2
	533685-US	Assembly, Star Knob		1
20	533683	Knob, Star Grip; M10-1.5 x 70mm L Stud		1
21	F05011-134	Washer, M10 Flat SAE		2
22	533677-US	Spring, .60 0Dx1 Long x.072 Wire Comp		1
23	F05004-276	Nut, M10-1.25Hex Nyl Lock		1

4.3 Left Guard

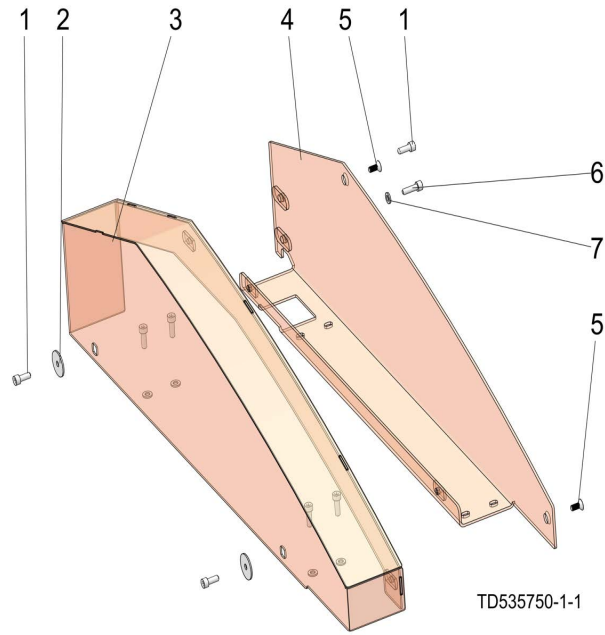

REF	PART #	DESCRIPTION	COMMENTS	QTY.
	535692-US	ASSEMBLY, LEFT GUARD COMPLETE		1
1	F05004-206	Screw, M6-1.0 x 16mm SHCS		3
2	F05011-12	Washer, 1/4 Fender		2
3	535690-1-US	Weldment, Left Guard Top		1
4	535730-1-US	Weldment, Left Guard Base		1
5	F05020-57	Bolt, M6-1.0 x 14 FSHC		2
6	F05020-15	Screw, M6-1 x 20 SHC		5
7	F05026-1	Washer, M6 Flat Class 4		5

4.4 Right Guard

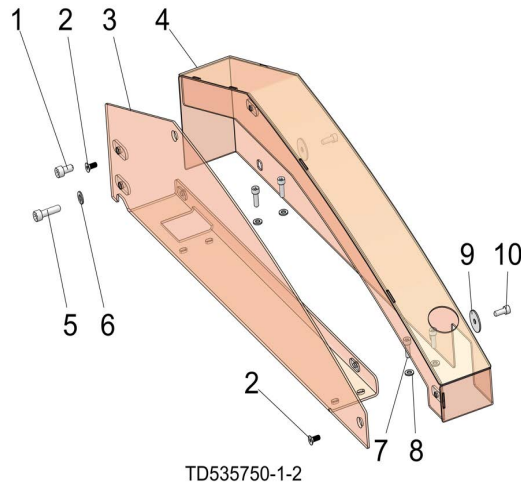

REF	PART #	DESCRIPTION	COMMENTS	QTY.
	535694-US	ASSEMBLY, RIGHT GUARD COMPLETE		1
1	F05021-10	Screw, M8-1.25x16 SHC		1
2	F05020-57	Bolt, M6-1.0 x 14 FSHC		2
3	535729-1-US	Weldment, Right Guard Base		1
4	535695-1-US	Weldment, Right Guard Top		1
5	F05021-1	Screw, M8-1.25 x 30 SHC		1
6	F05026-4	Washer, M8 Flat		1
7	F05020-15	Screw, M6-1 x 20 SHC		4
8	F05026-1	Washer, M6 Flat Class 4		4
9	F05011-12	Washer, 1/4 Fender		2
10	F05004-206	Screw, M6-1.0 x 16mm SHCS		2

4.5 Moving Plate

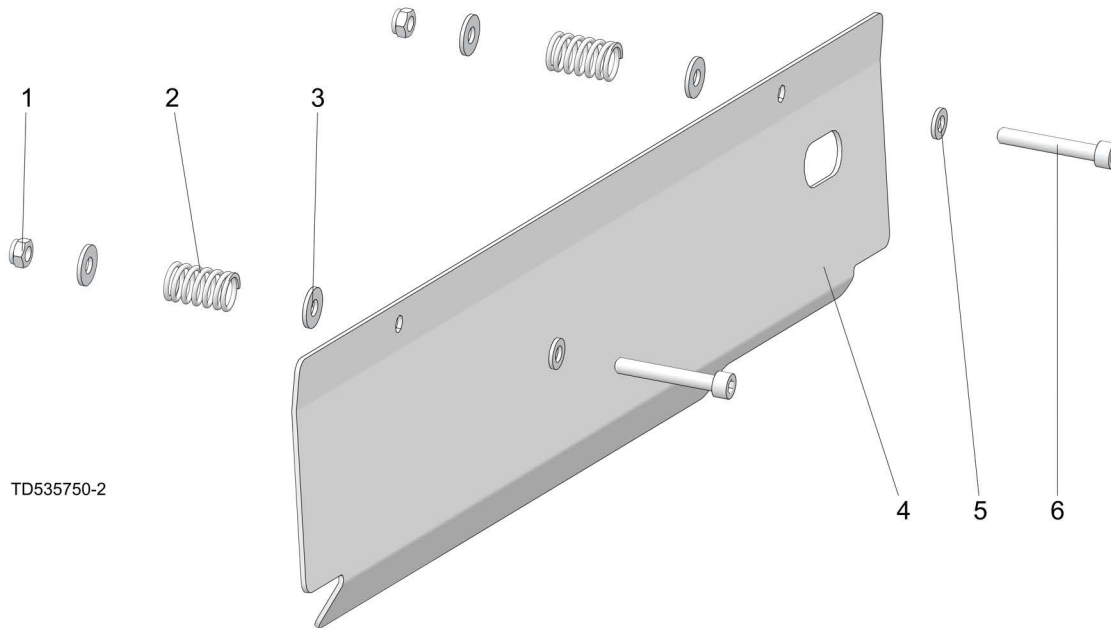

REF	PART #	DESCRIPTION	COMMENTS	QTY.
	535839-US	ASSEMBLY, MOVING PLATE		1
1	F05010-200	Nut, M6-1.0 Nylon Lock		2
2	533677-US	Spring, .60 0Dx1 Long x.072 Wire Comp		2
3	F05011-11	Washer, 1/4 SAE Flat		4
4	535838-1-US	Bracket, Moving Plate		1
5	F05026-1	Washer, M6 Flat Class 4		2
6	F05004-284	Bolt, M6-1.0x40mm SHCS		2

4.6 Table MP360

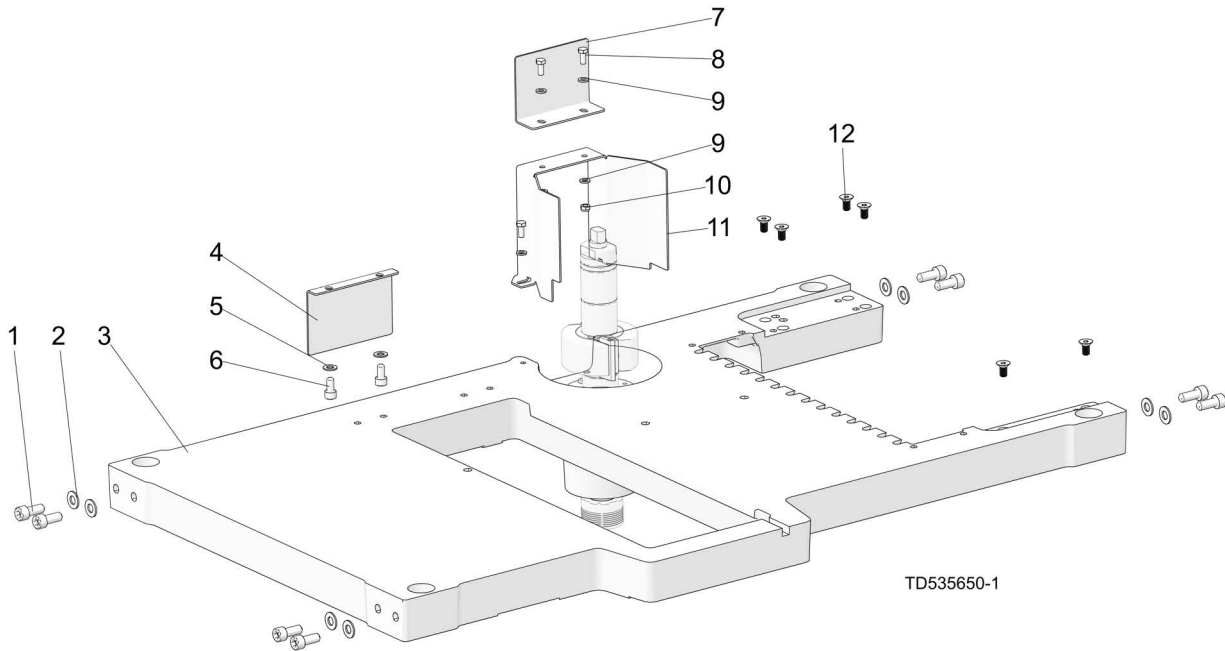

REF	PART #	DESCRIPTION	COMMENTS	QTY.
	535845-US	ASSEMBLY, MP360 TABLE COMPLETE		1
1	F05022-12	Bolt, M10-1.5 x 25 SHC		8
2	F05011-134	Washer, M10 Flat		8
3	535710-1	Table, MP360	535710-1 replaced 535710 after 3/22/2022 per ECN 38445.	1
	535710	Table, MP360		1
4	535882-1-US	Bracket, Top Guard		1
5	F05026-4	Washer, M8 Flat		2
6	F05021-10	Screw, M8-1.25x16mm SHC		2
7	535861-1-US	Bracket, Top Guard		1
8	F05020-7	Bolt, M6-1 x 14 Class 8 HH		4
9	F05026-1	Washer, M6 Flat Class 4		6
10	F05010-200	Nut, M6-1.0 Nylon Lock		2
11	535859-1-US	Bracket, Cutter Guard		1
12	F05021-42	Bolt, M8-1.25x16 Flat SHC		1
	535845-US	Spindle Assembly, Right	(See Section 4.7)	1

4.7 Left and Right Spindle Assembly

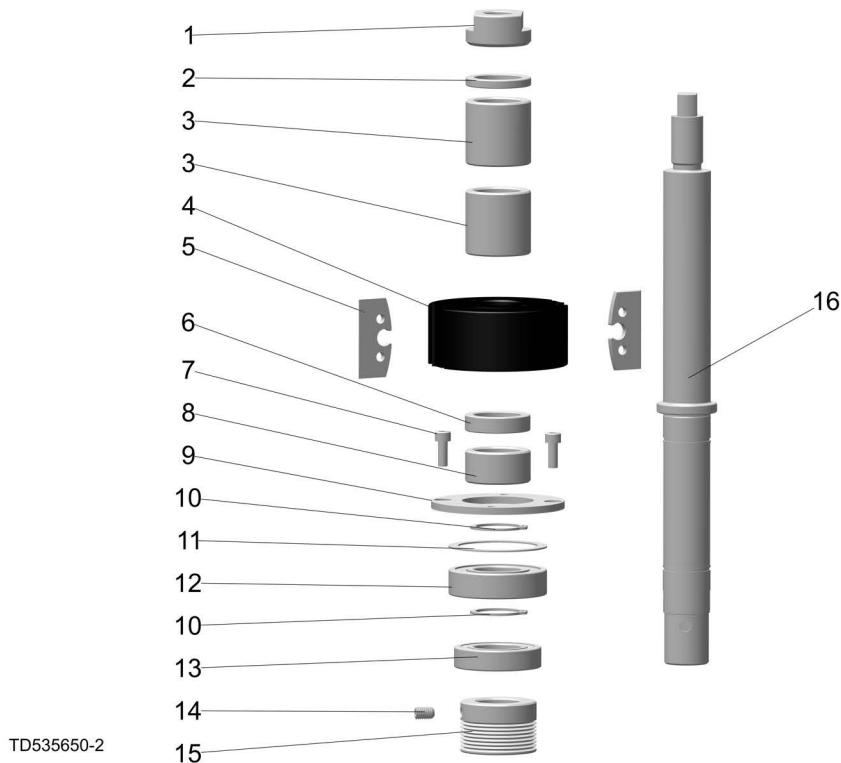

REF	PART #	DESCRIPTION	COMMENTS	QTY.
	535885-US	SPINDLE ASSEMBLY, MP360 FIXED		1
	535846-US	SPINDLE ASSEMBLY, MP360 MOVEABLE		1
1	535886-1-US	Bushing, 1-5/8xM20-1.5x25/32		1
2	533540-1-US	Bushing 1-5/8ODx1.183IDx0.205		2
3	533848-1-US	Bushing 1-5/8ODx1.183IDx1.583		2
4	TG56.2K	Cutterhead, 93D x 40L x 30B mm; Side 2kn	<i>Left/right cutterheads are mounted in opposite directions. Check for proper rotation.</i>	1
	240-010	Cutterhead, TB90-92 Steel		1
	533587	Cutter head		1
5	533588	Knife		2
6	533539-1-US	Bushing 1-5/8ODx1.183IDx0.394		1
7	F81001-21	Screw, M6-1.0x16 SHCS		2
8	533541-1-US	Bushing 1-5/8ODx1.183IDx0.795		1
9	533542-1-US	Plate, Clamping		1
10	F81090-23	Ring, 30 mm External Retaining		2
11	533543-US	Plate, Washer MP260		2
12	100787	Bearing, 6206 2RSR P6 Rolling (FAG, NSK, SKF)		2
13	096191	Bearing, 6006 2RSR		4
14	F05021-53	Screw, M8-1.25x12mm, Cup-Point Set		1
15	533586	Pulley, 8PJx48mmx28mm		1
16	535887-US	Shaft, MP360 Fixed Spindle	<i>Used with 535885-US</i>	1
	535847-US	Shaft, MP360 Moveable Spindle	<i>Used with 535846-US</i>	1

4.8 Lower Cutterhead

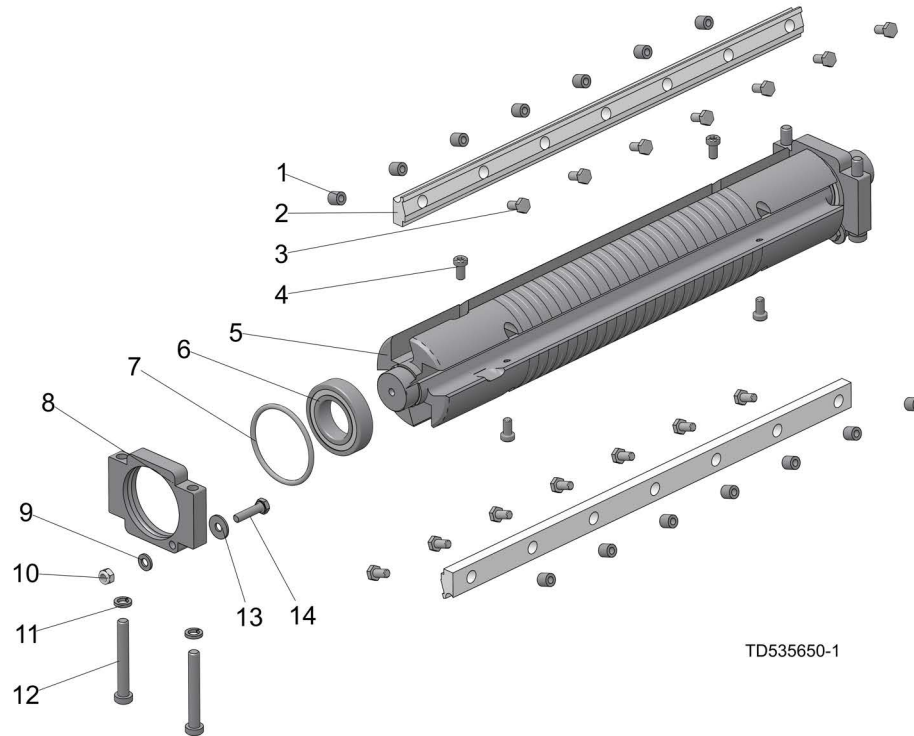

REF	PART #	DESCRIPTION	COMMENTS	QTY.
	536960-1	Assy, Cutterhead; 72D x 410L mm; 4kn	Replaced 536960 after 6/14/22 per ECN 38599	1
	536960	Assy, Cutterhead; 72D x 410L mm; 4kn	OBS	1
	241-060	KOMPLET KLINÓW MOCUJ?CYCH		1
1		Bushing M6	Not sold separately	14
2		Listwa dociskowa	Not sold separately	2
3	083595	Screw, M6x12 10.9 DIN933 ISO4017		14
4	F81001-80	Screw, M6x12-10.9		4
5	360-840	Lower Cutting Head MP360		1
6	096191	Bearing, 6006 2RSR		2
7	536959	O-RING		2
8	536958-1	Bearing Housing 1		2
9	F81053-1	Washer, 6.4 FE/ZN5 PN-78/M-82005		2
10	F81031-2	Nut, M6 Hex Nylon Lock Zinc		2
11	F81054-4	Washer, M8 Split Lock		4
12	F81002-41	Screw, M8x60-8.8 DIN 7984		4
13	F81053-11	Washer, 6.5 Zinc Flat		2
14	F81001-3	Screw, M6X25 5.8 FE/ZN5 PN-85/M-82105		2

4.9 Movable Cutter Fence

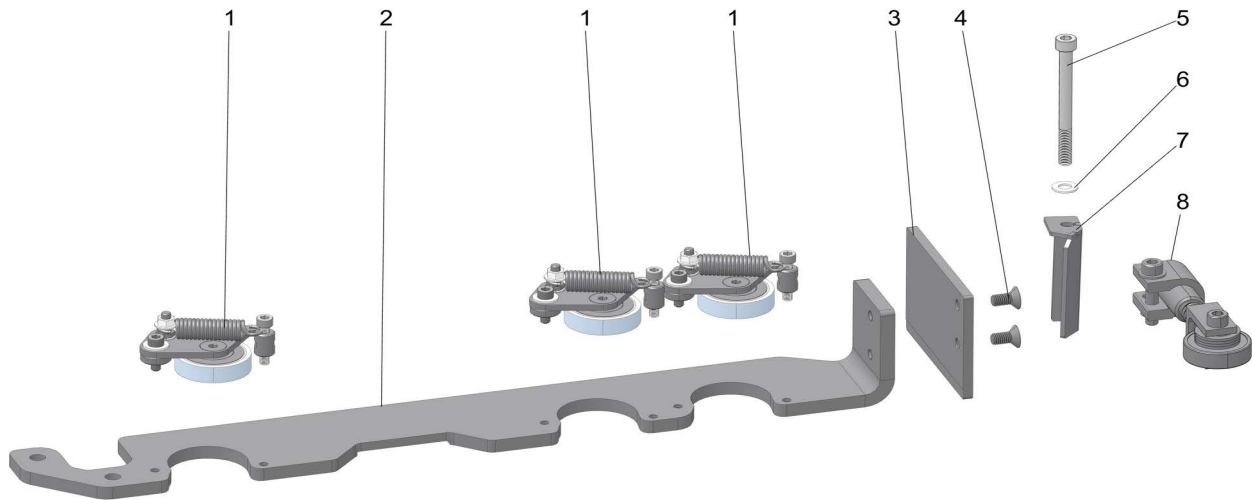

TDMP360_B101
TD535650-4

REF	PART #	DESCRIPTION	COMMENTS	QTY.
1	536980-US	Assembly, Clamp Roller Complete	(See Section 4.10)	3
2	535982-1-US	Bracket, Board Guard Fence		1
3	535983-1-US	Plate, Mount Plate		1
4	F05021-42	Bolt, M8-1.25x16 Flat SHC		2
5	F81002-44	Screw, M8-1.25x90mm SHC, Zinc		1
6	F05026-4	Washer, M8 Flat		1
7	133124	Bracket Wdmt, Guide Mount	Replaced 535984-1-US after 5/23/222 per ECN 3845	1
	535984-1-US	Bracket, Guide Mount	OBS	1
8	533550	Assembly, Pressure Roller	(See Section 4.11)	1

4.10 Clamp Rollers

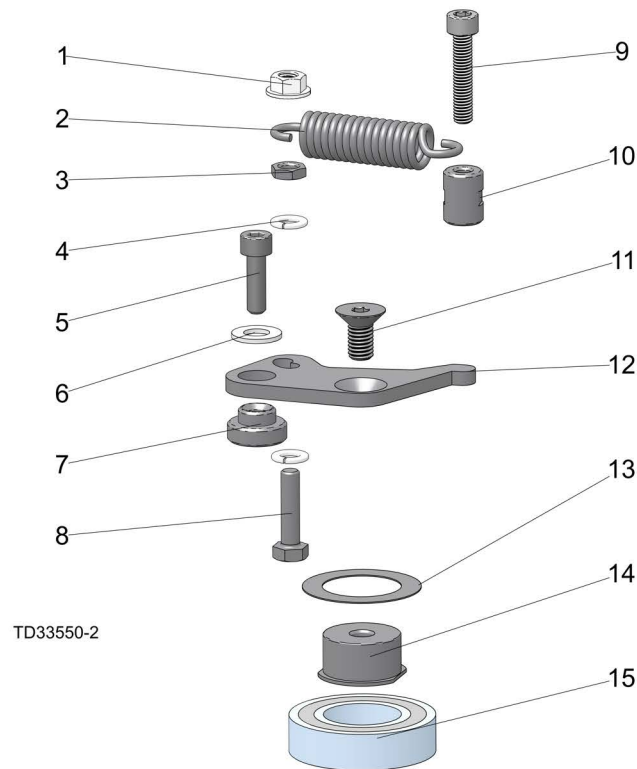

REF	PART #	DESCRIPTION	COMMENTS	QTY.
	536980-US	Assembly, Clamp Roller Complete		3
1	f05010-24	Nut, M6 x 1 Fanged Serated Lock		1
2	533571	Spring, 15mmx65mmx2.5mm Extension		1
3	f05010-226	Nut, M6X1 Metric Jam		1
4	f05026-2	Washer, M6 Split Lock		2
5	f05020-15	Screw, M6-1 x 20 SHC		1
6	f05026-4	Washer, M8 Flat		1
7	533632-us	Bushing, Flanged		1
8	f05020-33	Bolt, M6-1 x 25 Class 8 HH		1
9	f05020-25	Screw, M6-1x30 SHC		1
10	533633-1-us	Bushing, M6x1IDx0.5ODx.669		1
11	f05021-42	Bolt, M8-1.25x16 Flat SHC		1
12	533525-1-us	Plate, Bearing Movable		1
13	130466	Washer, 1IDx1.5ODx.016 SS		1
14	130465	Bushing, 25mm Bearing Mount		1
15	089652	Bearing 6005 2RS		1

4.11 Pressure Roller

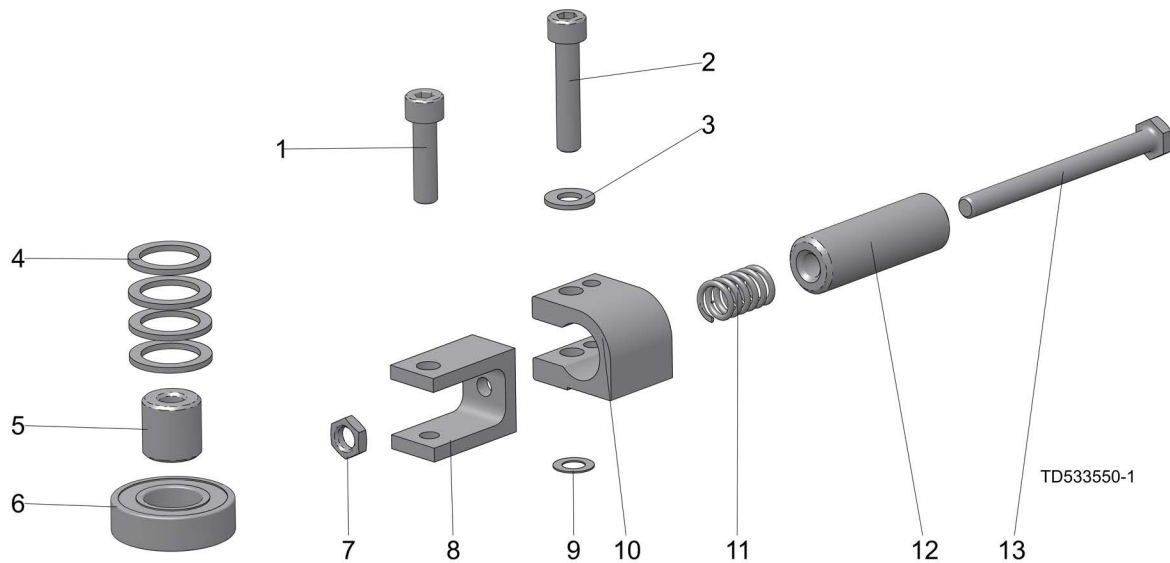

REF	PART #	DESCRIPTION	COMMENTS	QTY.
	533550	Assembly, PRESSURE ROLLER		1
1	F81002-31	Screw, Socket Head Cap M8x30- 8.8- Fe/zn5 Pn-m/82302		1
2	F81002-29	Screw M8x40 Shcs Zc 8.8 Din 912 Iso 4762		1
3	F81054-1	Washer, M8.4 Flat, Zinc		1
4	533555	Washer, 28/20-2		4
5	533554-1	Bushing, 8.2/20-20		1
6	093868	Bearing, 6004 2rs Cx Rolling		1
7	F81032-8	Nut, M8 Jam Fe/zn Class 04		1
8	533552	Connector, Aluminum		1
9	F81055-16	Ring Shim 14/8-05 Din 988		1
10	533551-1	Connector, Aluminum		1
11	533556	Spring, 12x25xn2		1
12	533553-1	Bushing, 8.5/20-60 Zinc-plated		1
13	F81002-16.	Bolt, M8 X 1.25 X 90mm Hh Ft Zinc		1

4.12 Table Sawdust Collection

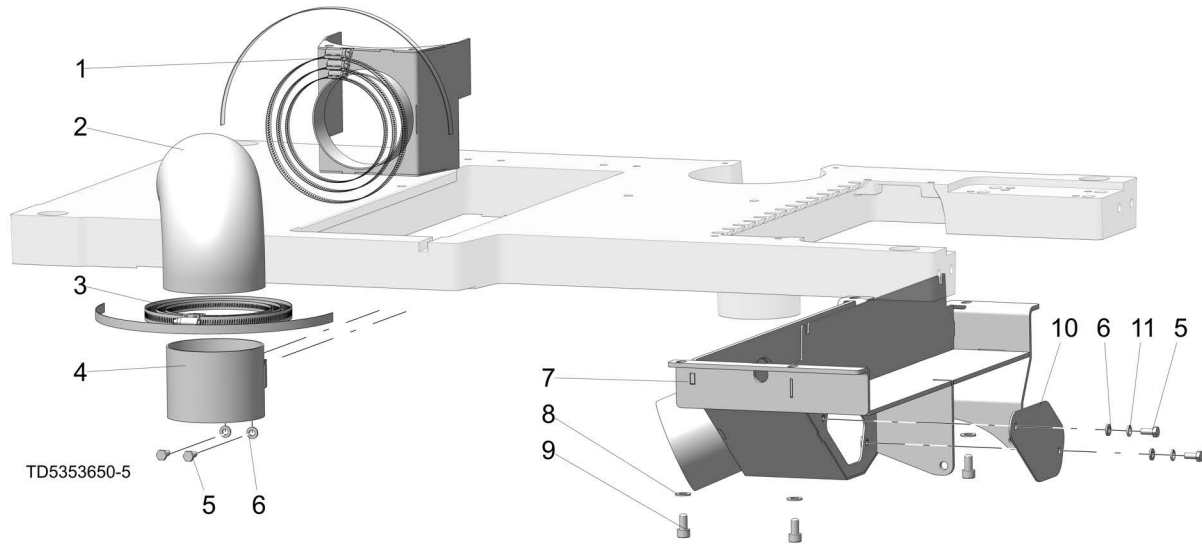

REF	PART #	DESCRIPTION	COMMENTS	QTY.
1	535979-US	Wldmnt, Sawdust Outlet		1
2	535883-US	Hose, 4x23 5/8 Clear Abrasion-Resist Duct		1
3	123356	Clamp, Worm, 3 1/8 - 6 Dia		2
4	535995-US	Wldmnt, Sawdust Outlet Connector		1
5	F05020-7	Bolt, M6-1 x 14 Class 8 HH		4
6	F05026-1	Washer, M6 Flat Class 4		4
7	535724-US	Wldmnt, Sawdust Chute Weldment		1
8	F05026-4	Washer, M8 Flat		4
9	F05021-10	Screw, M8-1.25x16mm SHC		4
10	535726-1-US	Plate, Cover		1
11	F05026-2	Washer, M6 Split Lock		2

4.13 Movable Side Cutter

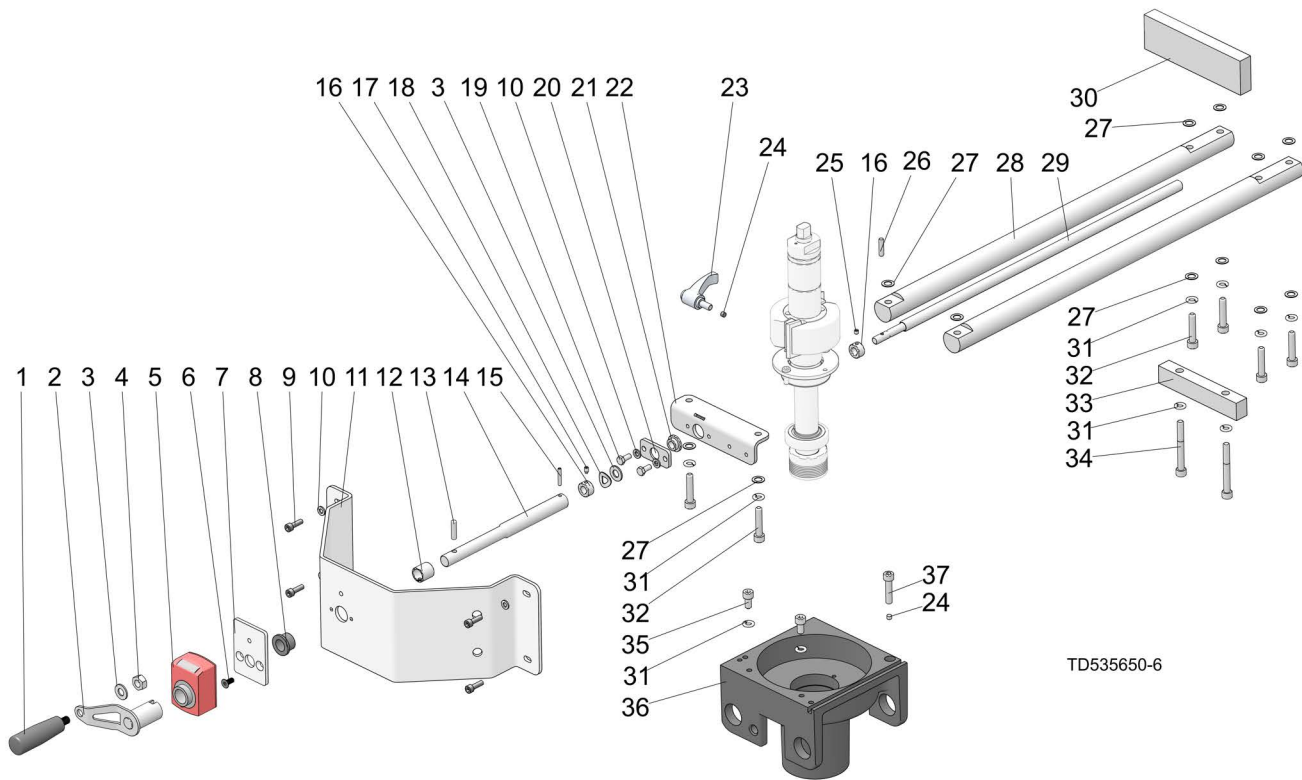

REF	PART #	DESCRIPTION	COMMENTS	QTY.
	536955-US	Assembly, Handle		1
1	533505-US	Plastic Tapered Handle with Revolving Grip		1
2	536954-US	Bracket, Side Handle		1
3	F05011-134	Washer, M10 Flat		2
4	F05010-85	Nut, M10-1.5 Hex		1
5	541149	Indicator, Spindle Digital Position		1
6	F05020-57	Screw, M6-1 x 14 Hex Flat Head		2
7	536000-1-US	Plate, Mounting of Counter		1
8	541373-US	Bushing, FL, 16mmIDx22ODx16L, Oil Bronze		1
9	F05020-15	Screw, M6-1 x 20 SHC		4
10	F05026-1	Washer, M6 Flat Class 4		8
11	535646-1-US	Bracket, Small Side Cover		1
12	541138-US	Bushing, 0.786ODx0.630IDx0.787		1
13	F05012-134	Pin, 1/4x1 Dowel		1
14	535998-1-US	Bushing, Connector		1
15	F81048-82	Pin, M4x24mm Roll		1
16	535997-1-US	Bushing, .394IDx.75ODx.394		2
17	F81014-15	Screw, M5-0.8x8mm SHSS Dog Point		1
18	F81055-18	Washer, M10 Wave DIN 137B		1
19	F05020-7	Bolt, M6-1 x 14 Class 8 HH		4

4

Outside Body*Movable Side Cutter*

REF	PART #	DESCRIPTION	COMMENTS	QTY.
20	535991-1-US	Plate, Slide Bushing Plate		1
21	541372	Self Lubricating Bearing, AMES n10/n16/n22-8		1
22	535989-1-US	Bracket, Screw Mounting Plate		1
23	535988-US	Adjustable Handle ERZ.63 p-M8x-16		1
24	535987-US	Round, Slide .236Dia x.157		2
25	F81014-14	Screw, M6-1.0x5mm SHSS Cup Point		1
26	F81045-5	Pin, M6x24mm Dowel		1
27	535990-US	Washer, Shim 0.39IDx0.63ODx0.031		12
28	535981-US	Drawn Rod 1.181x24.33		2
29	535996.	Cutter, Trapezoidal Screw		1
30	536957-1-US	Bar, 3/4x1.969x6 25/32		1
31	F05011-45	Washer, 8mm Split Lock, Zn		10
32	F05021-6	Screw, M8-1.25x40mm SHC		6
33	536956-1-US	Bar, 3/4x1x5 1/2		1
34	F05021-41	Screw, M8-1.25x70mm SHCS BO		2
35	F05021-10	Screw, M8-1.25x16mm SHC		2
36	546837-1	Base, Spindle Mount	546837-1 replaced 260-510B after 11/30/2021 per ECN 38261	1
	260-510B	Base, Spindle Mount		1
37	F81002-58	Screw, M8-1.25x35mm SHC		1

SECTION 5 INSIDE BODY

5.1 Rods and Feed Assembly

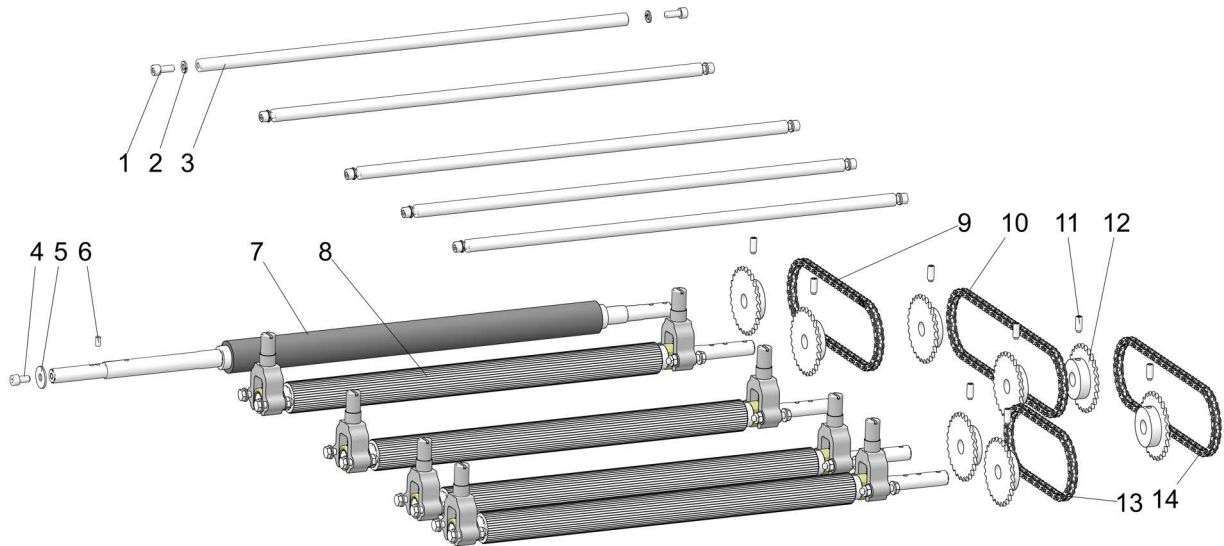

REF	PART #	DESCRIPTION	COMMENTS	QTY.
	535835-US	ASSEMBLY, ROD SET		
1	F05005-150	Bolt, M8x1.25x20mm SHCS		10
2	F05011-45	Washer, M8 Split Lock		10
3	535834-1-US	Round, 5/8x23.30 inch Rod		5
	535831-US	ASSEMBLY, FEED MP360		
4	F05021-10	Screw, M8-1.25x16 SHC		1
5	535853-1-US	Washer, 1.10ODx14Ga		1
6	F81048-13	Pin, Dowel M6x12		1
7	535740	Roller, Feed; Rubber		1
8	535732	Roller, Groove Feed; Steel		4
9	535876-US	Chain, #35x66 Pitches w/ML		1
10	535877-US	Chain, #35x81 Pitches w/Master Link	535877-US added one Pitch after 12/8/2021 per ECN 38274	1
	535877-US	Chain, #35x80 Pitches w/Master Link		1
11	F81002-77	Screw, M8-1.25x20mm SHSS Dog Point		8
12	535832-US	Assembly, Sprocket, #35, 27T		8
13	535879-US	Chain, #35x50 Pitches w/Offset & ML		1
14	535878-US	Chain, #35x72 Pitches w/ML		1

5.2 Drive Shaft Assemblies

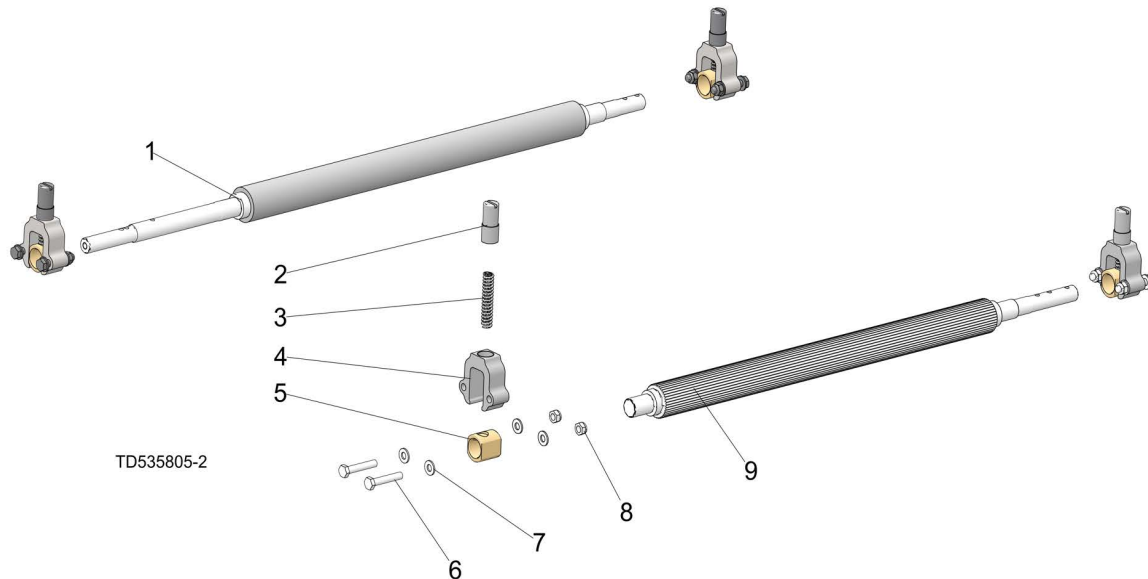

REF	PART #	DESCRIPTION	COMMENTS	QTY.
	535740	ROLLER, FEED, RUBBER		1
1	535739	Shaft with Protective Cover, MP360		1
	535737	Housing, Bearing		2
2	535734-1	Adjustment Screw		1
3	535736	Spring		1
4	535733-1	Slide Bushing Housing		1
5	535738	Slide Bushing		1
6	F81002-14	Bolt M8x45 HH Zc Ft 8.8 Din 933		1
7	F81054-1	Washer, M8.4 Flat, Zinc		1
8	F81032-2	Nut, M8-8-b, Hex, Nylon Lock Zinc		1
	535732	ROLLER, GROOVE FEED; STEEL (includes items 2 through 8)		4
9	535833-1	Steel Drive Shaft		1

5.3 Up/Down Limiter

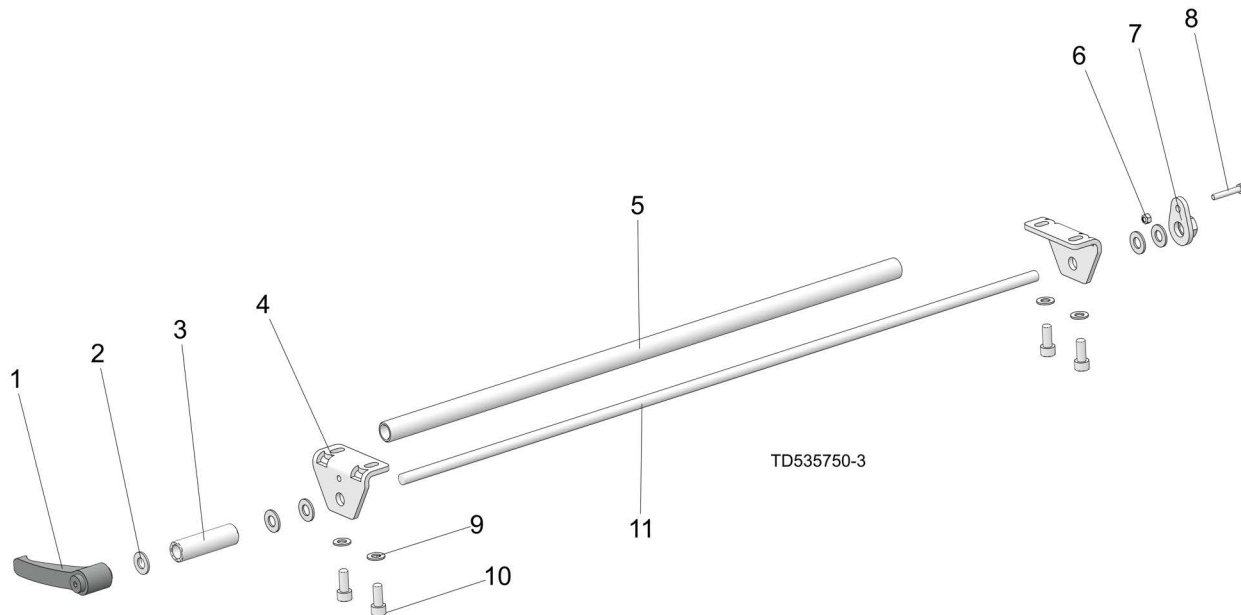

REF	PART #	DESCRIPTION	COMMENTS	QTY.
	535870-US	ASSEMBLY, UP/DOWN LIMITER		
1	535868-US	Handle, Adjustable ERZ.78 A-M10		1
2	F05011-134	Washer, M10 Flat SAE		5
3	535866-1-US	Tubing, 3/4ODx11GAx2 17/32		1
4	535863-1-US	Bracket, Screw Mounting Plate		2
5	535862-1-US	Tubing, 3/4ODx11GAx22 27/32		1
6	F05027-3	Nut, M5-.8 Class 8 Hex Nylock		1
7	535865-1-US	Weldment, Tab/Nut		1
8	F81000-9	Bolt, M5-0.8x25 HH Class 8.8		1
9	F05026-4	Washer, M8 Flat		4
10	F05005-150	Bolt, M8x1.25x20mm SHCS		4
11	535867	Rod, M10-1.5 x 720mm L		1

5.4 Up/Down Feed System

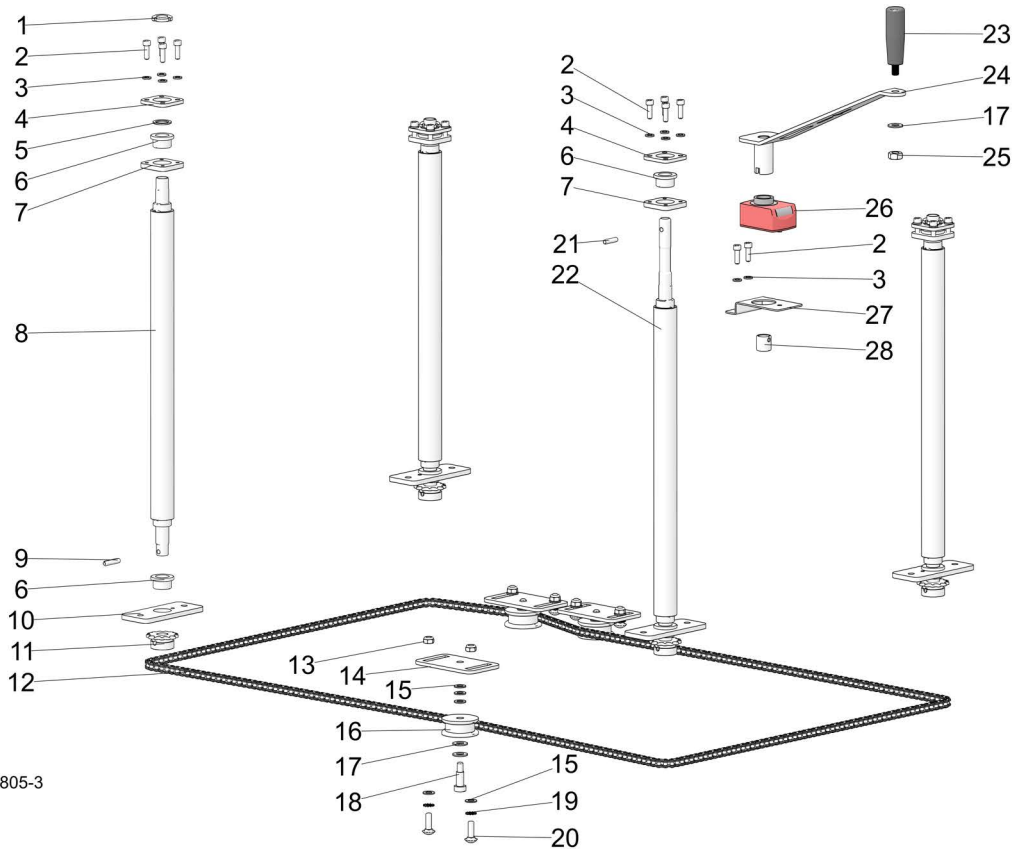

TD535805-3

REF	PART #	DESCRIPTION	COMMENTS	QTY.
	535960-US	ASSEMBLY, UP/DOWN FEED		
	F05026-4	Washer, M8 Flat		6
1	535966	Nut, KM3 M17x1 NYLOCK DIN 981		3
2	F05020-15	Screw, M6-1 x 20 SHC		18
3	F05026-1	Washer, M6 Flat Class 4		18
4	535963-1-US	Plate, 1 13/16x7Ga		4
5	535967-US	Washer, 1.00ODx0.73IDx.062		3
6	546904	Bushing 18x25x16 Flanged 32-4 Bronze	546904 replaced 535954 after 12/30/2021 per ECN 38297	8
	535954	Bushing 12.3/18-16 Flange 32-4 mm		8
7	535962-1-US	Plate, 1 13/16x1/4		4
8	535951	Screw, Tr32x6 x 540L mm		3
9	F05029-6	Pin, 6MM x 30MM Roll		4
10	535964-1-US	Plate, Support		4
11	535953-US	Sprocket, #35, 13T		4
12	536975-US	Chain, #35x328 Pitches w/ML		1
13	F05010-132	Nut, M8-1.25 Hex Nylock		6
	535970-US	Assembly, Chain Tensioner		3
14	535969-1-US	Weldment, Chain Tensioner		1
15	F05026-4	Washer, M8 Flat		3

REF	PART #	DESCRIPTION	COMMENTS	QTY.
16	533576-US	Roller, Tensioner		1
17	F05011-134	Washer, M10 Flat SAE		2
18	f05022-27	Bolt, Shoulder 10mmDia x 20mmL Plain		1
19	F81054-3	Washer, M8 Star Ext Tooth		6
20	F05021-17	Bolt, M8-1.25 x 25 Carriage Class 8.8		6
21	F81045-5	Pin, M6x24mm Dowel		1
22	535952	Screw, Tr32x6 x 620L mm		1
	535975-US	Assembly, Handle		1
17	F05011-134	Washer, M10 Flat SAE		1
23	533505-US	Plastic Tapered Handle w/ Revolving Grip		1
24	535973-1-US	Weldment, Handle		1
25	F05010-85	Nut, M10-1.5 Hex		1
26	541150	Indicator, Up/Down Digital Position		1
27	535961-1-US	Bracket, Support Counter		1
28	541138-US	Bushing, 0.786ODx0.631Dx0.787		1

5.5 Upper Cutterhead

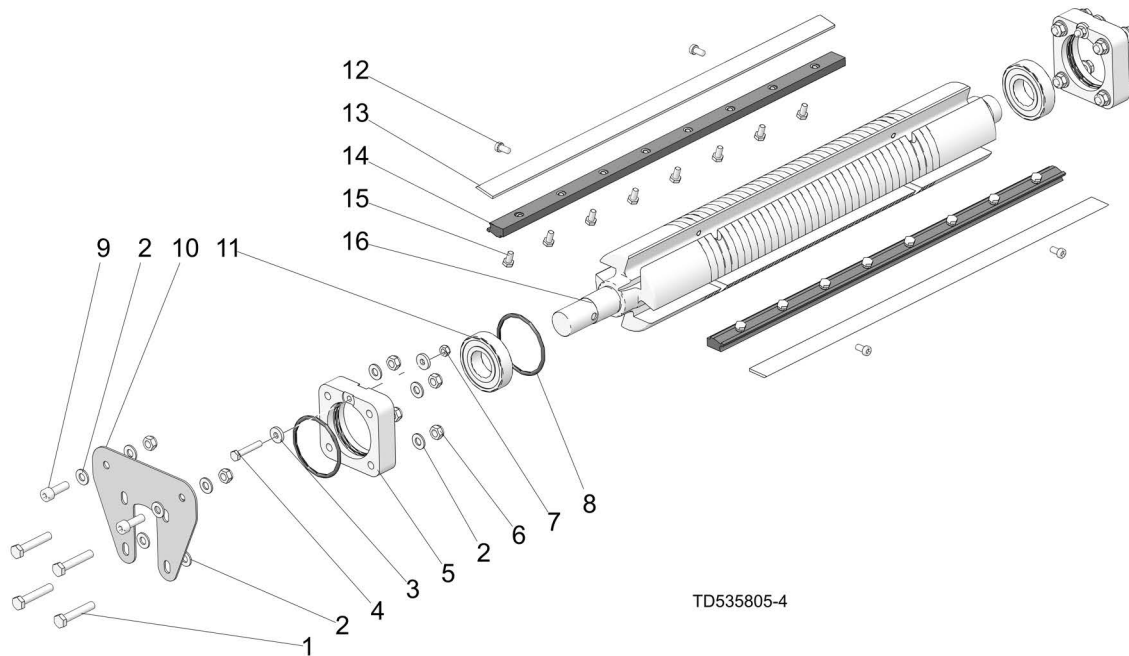

REF	PART #	DESCRIPTION	COMMENTS	QTY.
	536961	ASSEMBLY, CUTTERHEAD; 88D X 510L MM; 4KN		
	536964	Upper Cutter Bearing Housing Assembly		2
1	F81002-14	Bolt M8x45 Hh Zc Ft 8.8 Din 933		4
2	F81054-1	Washer, M8.4 Flat, Zinc		8
3	F81053-13	Washer 6,4 Zc Din 7349		2
4	F81001-71	Bolt M6x35 Hh Zc 8.8 Pt Din 931		1
5	533590-1	Housing, Bearing		1
6	F81032-2	Nut, M8-8-b, Hex, Nylon Lock Zinc		4
7	F81031-2	Nut, M6 Hex Nylon Lock Zinc		1
8	533592	O-ring, Bearing Housing		2
9	F81002-21	Screw, M8x25 Shc 8.8 Fe/zn5 Pn-m/82302		2
10	536969-1	Mounting Plate		1
11	100787	Bearing, 6206 2rsr P6 Rolling (Fag, Nsk, Skf)		1
12	F81001-80	Screw M6x12 Lshcs 10.9 Din 7984		4
13	TPK510.25MP	Knife, Planer; Hss; 510mm (20") L W/o Notch		2
14	360-103	Mounting Wedge Set		2
15	083595	Bolt M6x12 10.9 Din 933 Iso 4017		8
16	360-104-1	Upper Cutter		1

5.6 Guard Set

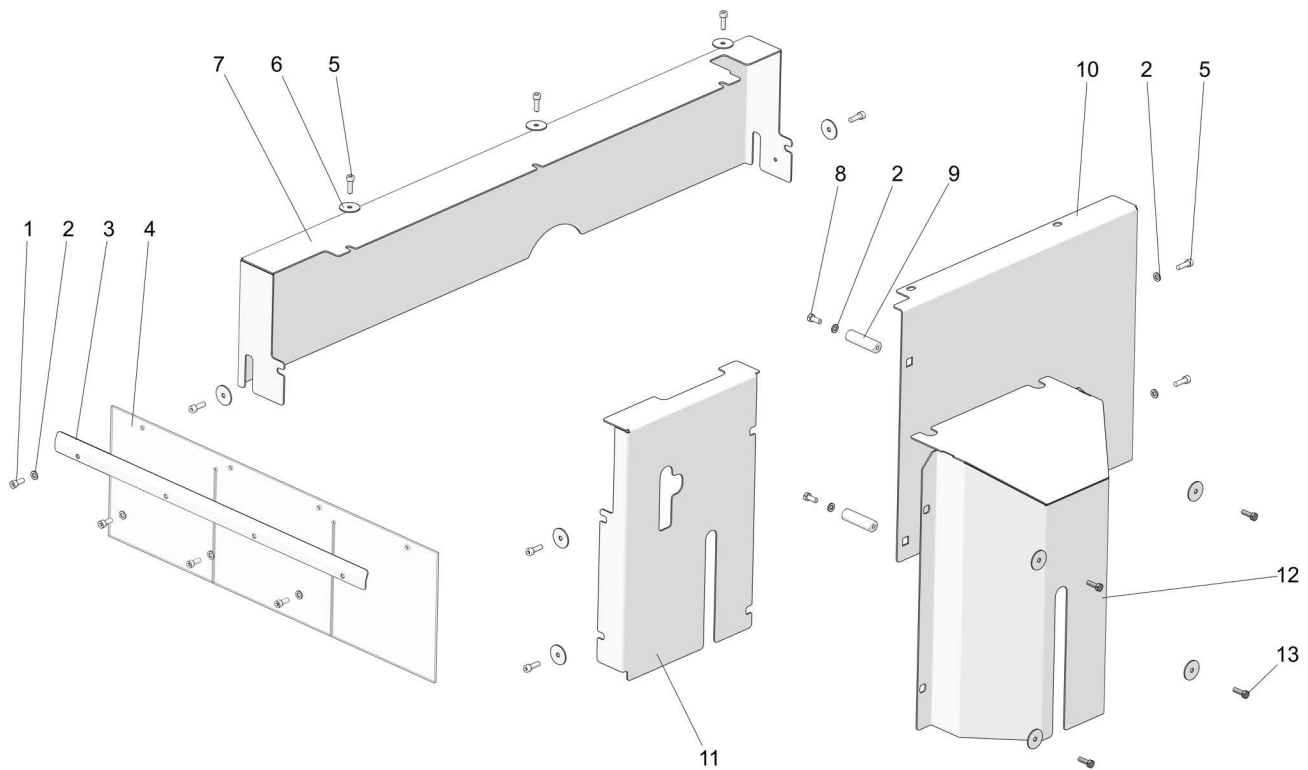

TD535805-5

REF	PART #	DESCRIPTION	COMMENTS	QTY.
	535850-US	ASSEMBLY, FLEXIBLE COVER COMPLETE		
1	F05004-206	Screw, M6-1.0 x 16mm SHCS		4
2	F05026-1	Washer, M6 Flat Class 4		4
3	535849-1-US	Bracket, Cover Support		1
4	535851-US	Plate, Flexible Cover		1
	535744-US	ASSEMBLY, GUARD SET		
2	F05026-1	Washer, M6 Flat Class 4		4
5	F05020-15	Screw, M6-1 x 20 SHC		9
6	F05011-12	Washer, 1/4 Fender		11
7	535632-1-US	Bracket, Back Guard		1
8	F05004-219	Screw, M6x1.0x16mm 8.8 HH		2
9	535743-1-US	Bushing, M6-5/8x2 1/8		2
10	535742-1-US	Bracket, Front Right Guard		1
11	535741-1-US	Bracket, Front Left Guard		1
12	535654-1-US	Weldment, Middle Guard		1
13	F05020-6	Bolt, M6-1 x 20 Class 8 HH	Replaced F05004-275 after 7/21/22 per ECN 38642	4
	F05004-275	Screw, M6-1.0 x 12mm BHCS Black Oxide		4

5.7 Inside Body Frame

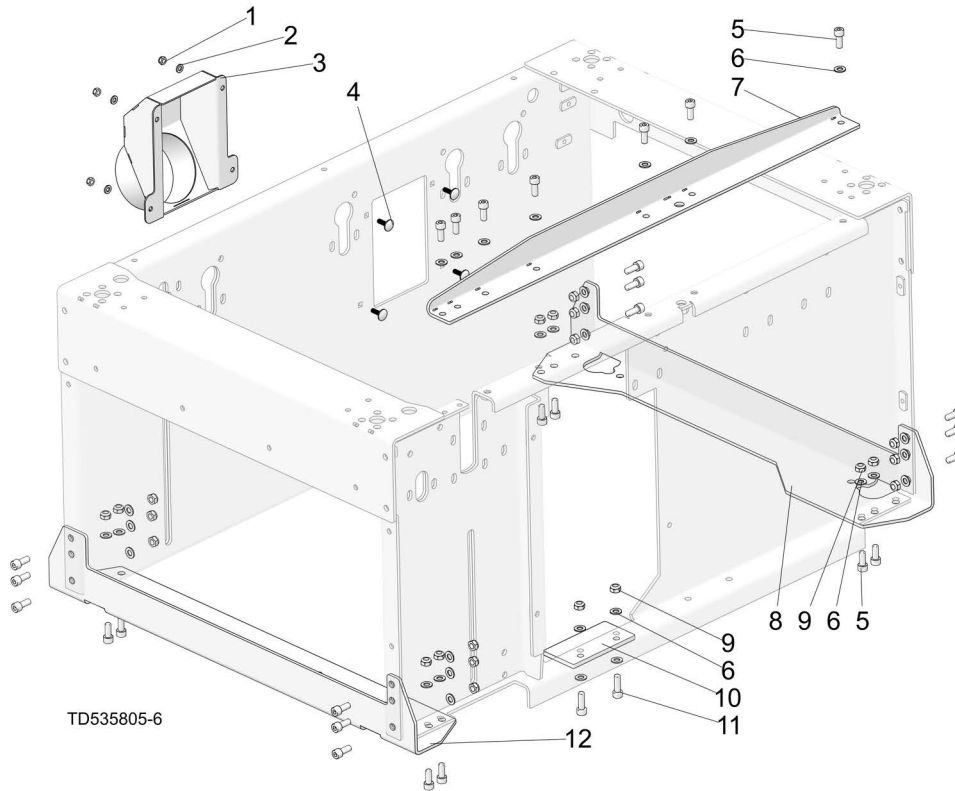

REF	PART #	DESCRIPTION	COMMENTS	QTY.
	535805-US	ASSEMBLY, INSIDE BODY COMPLETE		
1	F05010-200	Nut, M6-1.0 Nylon Lock		4
2	F05026-1	Washer, M6 Flat Class 4		4
3	535630-1-US	Wldmnt, Sawdust Chute Weldment		1
4	F05020-58	Bolt, M6-1.0 x 20 Carriage		4
5	F05005-150	Bolt, M8x1.25x20mm SHCS		27
6	F05026-4	Washer, M8 Flat		31
7	535691-1-US	Bracket, Top Cover Lock		1
8	535836-US	Bracket, Left Upper Bracket		1
9	F05010-132	Nut, M8-1.25 Hex Nylock		22
10	537662-1-US	Plate, Up/Down Limiter		1
11	F05021-33	Screw, M8-1.25x25 SHC BO		2
12	535837-US	Bracket, Right Upper Bracket		1

SECTION 6 MOTOR KITS

6.1 Motor Kit

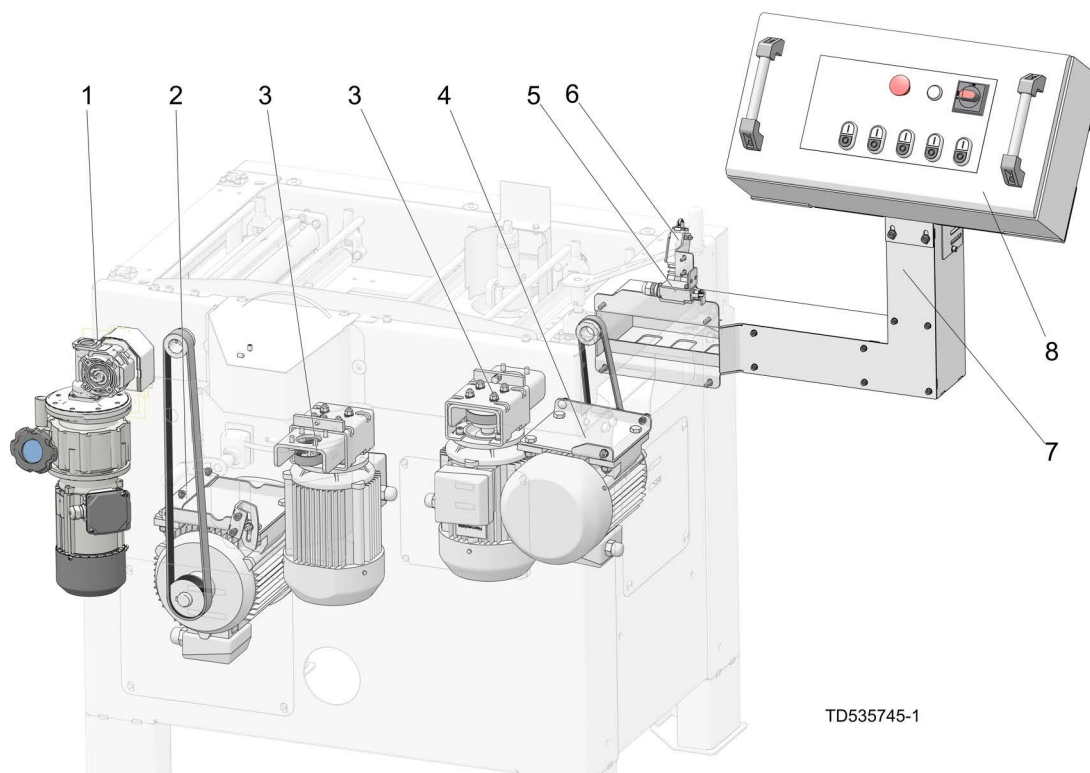

REF	PART #	DESCRIPTION	COMMENTS	QTY.
	535745-2U-US	Assembly, Motor Kit MP360EB 3x230V		1
1	535802-US	Assembly, MP360 Feed Drive	(See Section 6.2)	1
2	535810-U-US	Assembly, Horizontal Upper Cutter Drive	(See Section 6.3)	1
3	533647-U-US	Assembly, Side Cutter Drive	(See Section 6.4)	2
4	535728-U-US	Assembly, Horizontal Bottom Cutter Drive	(See Section 6.5)	1
5	535840-US	Assembly, Front Cover Safety Switch	(See Section 6.6)	1
6	535844-US	Assembly, Top Cover Safety Switch	(See Section 6.6)	1
7	133004	Assembly, Electrical Box Mount	(See Section 6.7) 133004 replaced 535715-US after 3/9/2022 per ECN 38420	1
8	121321	Assembly, Enclosure, MP360, 240V, 3Ph	(See Section 6.9) 121321 replaced 532800-2U after 3/9/2022 per ECN 38420	1
	121168	Cable Assembly, MP360 3ph, Under Cutter Mot	Cable information is found in the Electrical Information manual	1
	121169	Cable Assembly, MP360 Right Vert Cut		1
	121170	Cable Assembly, MP360 Left Vert Cut		1
	121171	Cable Assembly, MP360 Upper Cut		1
	121172	Cable Assembly, MP360 Feed		1
	121173	Cable Assembly, MP360 LS1		1
	121174	Cable Set, MP360 LS2		1

6.2 Feed Motor Assembly

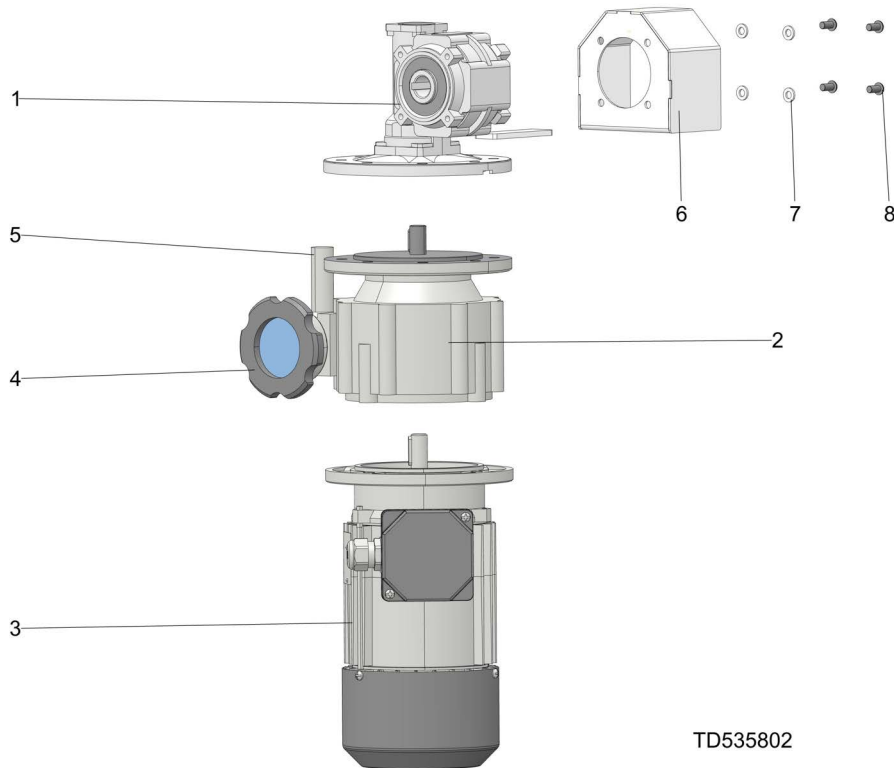

TD535802

REF	PART #	DESCRIPTION	COMMENTS	QTY.
	535802-US	Assembly, MP360 Feed Drive		1
	532808-UL	Motorgear KC 40/P15 160/14+NF005		1
1	535749	Reducer, KC40/P15 160/14 V6 H18		1
2	535748	Variator NF005 160/14 B5 V3		1
3	535747	Motor, 0.75kW, 1ph, 460V, 60Hz, IEC71B5		1
4	546928-S	Knob, Variable Speed		1
5	084671	Oil Fill Plug For Planer/Moulders		1
	535855-US	Assembly, Gearbox Cover Complete		1
6	535858-1-US	Weldment, Gearbox Cover		1
7	F05026-1	Washer, M6 Flat Class 4		4
8	F05004-275	Screw, M6-1.0 x 12mm BHCS Black Oxide		4

6.3 Upper Cutter Motor Assembly

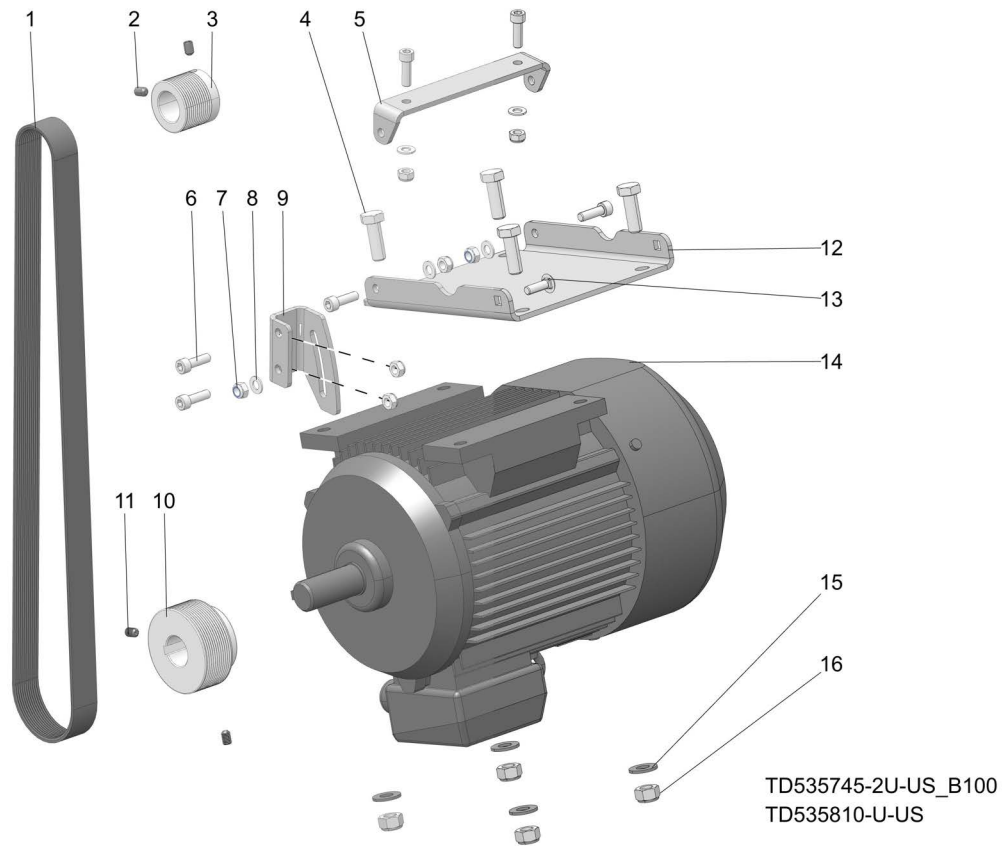

REF	PART #	DESCRIPTION	COMMENTS	QTY.
	535810-U-US	Assembly, Horizontal Upper Cutter Drive		
1	535801-US	Belt, Multi-Groove 12PJ1245		1
2	F05021-53	Screw, M8-1.25x12mm SHSS Cup Point	F05021-53 replaced F81002-105 after 1/27/2022 per ECN 38338.	2
3	535809	Pulley, 12PJx48mmx28mm		1
4	f05023-15	Bolt, M12-1.75 x 35mm 8.8 HH Zinc		4
5	535807-1-US	Bracket, Motor Handle		1
6	F05021-33	Screw, M8-1.25x25 SHC BO		6
7	F05010-132	Nut, M8-1.25 Hex Nylock		7
8	F05026-4	Washer, M8 Flat		5
9	535804-1-US	Bracket, Handle		1
10	535808-US	Pulley, 12PJx78.4mmx28mm		1
11	F05021-53	Screw, M8-1.25x12mm SHSS Cup Point	Replaced F05021-7 after 8/26/2022 per ECN 386669	2
	F05021-7	Screw, M8-1.25 x20 SHFP Set		2
12	535806-1-US	Bracket, Motor Plate		1
13	F05021-17	Bolt, M8-1.25 x 25 Carriage Class 8.8		1
14	537388-UL	MTR, 5.5kW, 3ph, 230/460, 60Hz, IE3 IMB3		1
15	F05011-124	Washer, M12 Flat Zinc		4
16	F05010-209	Nut, M12x1.75 Hex Nylock Zinc		4

6.4 Side Cutter Motor Assemblies

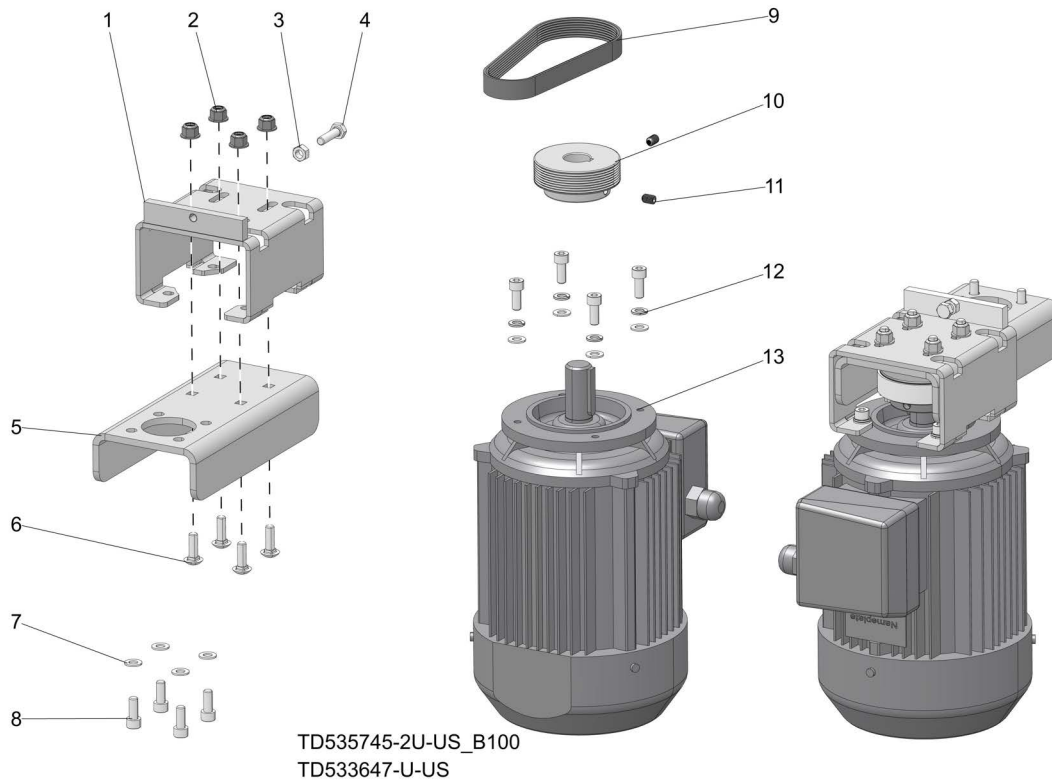

REF	PART #	DESCRIPTION	COMMENTS	QTY.
	533647-U-US	Assembly, SIDE CUTTER DRIVE		2
1	533649-1-US	Weldment, MP200 Motor Mount		1
2	F05027-44	Nut, M8 x 1.25 Flanged Nylock		4
3	F05010-162	Nut, M8-1.25 Free Zinc Plate	Replaced F05027-17 after 9/21/22 per ECN 38723	1
	F05027-17	Nut, M8-1.25 Swaged Hex		1
4	F05021-18	Bolt, M8-1.25 x 30 HH FT Class 8.8		1
5	130952	Plate, Motor Adjustment		1
6	F05021-17	Bolt, M8-1.25 x 25 Carriage Class 8.8		4
7	F05026-4	Washer, M8 Flat	Replaced F05011-131 after 8/26/22 per ECN 38669	8
	F05011-131	Washer, M8 Flat Zinc 100PK		8
8	F05005-150	Bolt, M8x1.25x20mm SHCS		8
9	533680-US	Belt, Multi-Groove 8 PJ 432(170J8)		1
10	533585-US	Pulley, 8PJx78.4mmx24mm		1
11	F05021-53	Screw, M8-1.25x12mm SHSS Cup Point	(1) Added and (1) replaced F05021-7 after 8/26/22 per ECN 38669	2
	F05021-7	Screw, M8-1.25 x20 SHFP Set		1
12	F05011-45	Washer, M8 Split Lock		4
13	537385-UL	Motor Nidec 3kW,2P, M90XL IMB14/C140		1

6.5 Bottom Cutter Motor Assembly

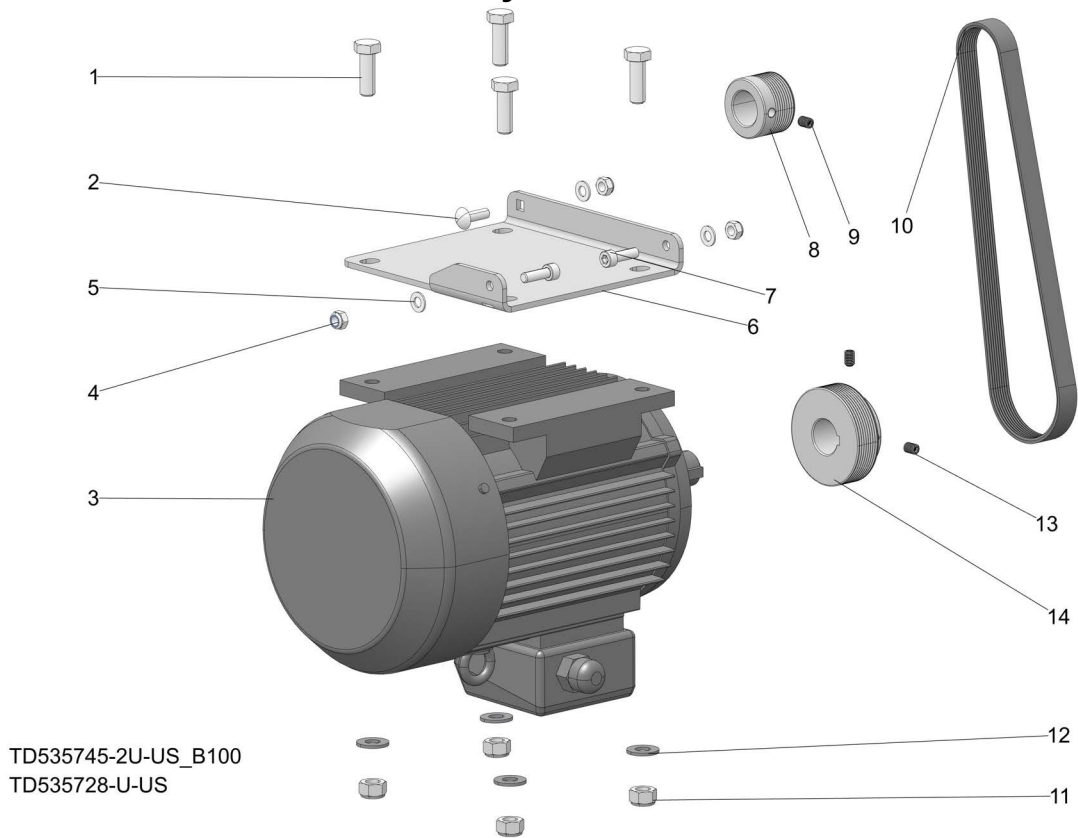

REF	PART #	DESCRIPTION	COMMENTS	QTY.
	535728-U-US	Assembly, Horizontal Bottom Cutter Drive		1
1	F05023-15	Screw, M12-1.75 x 25 Wing Head Thumb		4
2	F05021-17	Bolt, M8-1.25 x 25 Carriage Class 8.8		1
3	537387-UL	MTR, 4kW, 3ph, 230/460, 60Hz, IE3, IMB3		1
4	F05010-132	Nut, M8-1.25 Hex Nylock		3
5	F05026-4	Washer, M8 Flat	Replaced F05011-131 after 8/26/2022 per ECN 38669	3
	F05011-131	Washer, M8 Flat Zinc 100PK		3
6	535727-1-US	Bracket, Motor Plate		1
7	F05021-33	Screw, M8-1.25x25 SHC BO		2
8	533586	Pulley, 8PJx48mmx28mm		1
9	F05021-53	Screw, M8-1.25x12mm SHSS Cup Point	F05021-53 replaced F81002-105 after 1/27/2022 per ECN 38338.	1
10	535803-US	Belt, Multi-Groove 8 PJ 737(290J8)		1
11	F05010-209	Nut, M12x1.75 Hex Nylock Zinc		4
12	F05011-124	Washer, M12 Flat Zinc		4
13	F05021-53	Screw, M8-1.25x12mm SHSS Cup Point	(1) Added and (1) replaced F05021-7 after 8/26/22 per ECN 38669	2
	F05021-7	Screw, M8-1.25 x20 SHFP Set		1
14	533585-P-US	Pulley, 8PJx78.4mmx28mm		1

6.6 Safety Switches

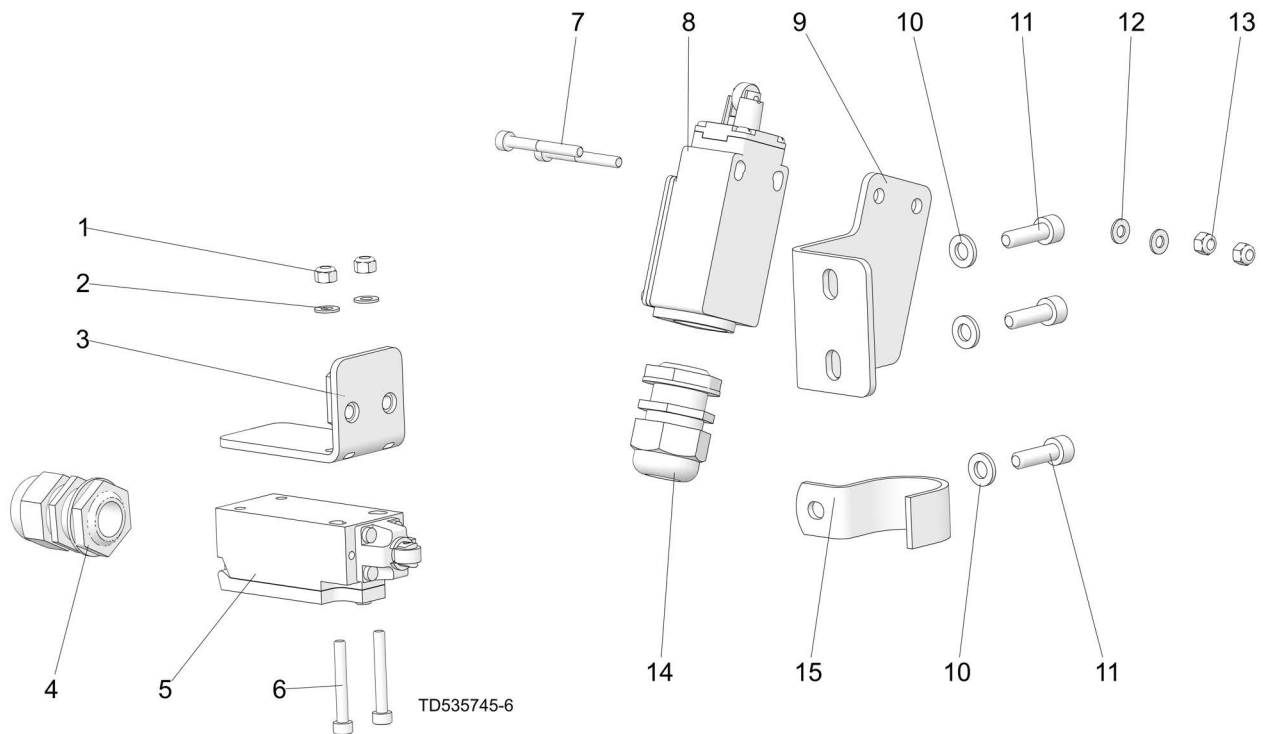

REF	PART #	DESCRIPTION	COMMENTS	QTY.
	535840-US	Assembly, Front Cover Safety Switch		1
1	F05027-8	Nut, M4-.7 Class 8 Nylock		2
2	F05011-132	Washer, M4 Flat SS PK/100		2
3	535842-US	Weldment, Front Cover Safety Switch		1
4	F81096-41	Connector, Cord Grip 20HML		1
5	537641	Switch, Safety D4N-4132		1
6	F05004-271	Screw, M4-0.7x30mm SHCS PK/100		2
	535844-US	Assembly, Top Cover Safety Switch		1
7	F05020-81	Screw, M4-0.7x35mm SHCS Blk Ox		2
8	100910	Switch, TVS Travel Limit		1
9	535843-1-US	Bracket, Safety Switch Bracket		1
10	F05026-1	Washer, M6 Flat Class 4		3
11	F05020-15	Screw, M6-1 x 20 SHC		3
12	F05011-132	Washer, M4 Flat SS PK/100		2
13	F05027-8	Nut, M4-.7 Class 8 Nylock		2
14	F81096-41	Connector, Cord Grip 20HML		1
15	P05436	Clamp, 1 EMT		1

6.7 Electrical Box Mount

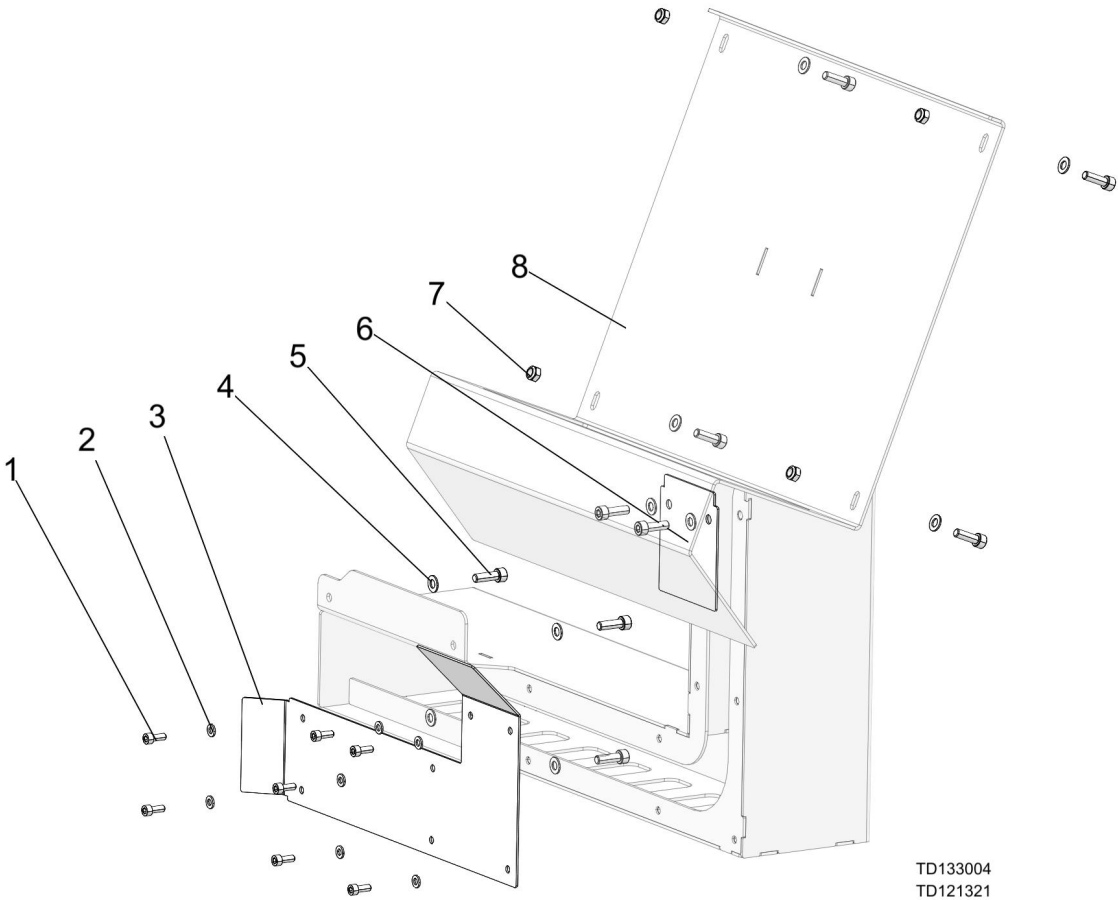

TD133004
TD121321

REF	PART #	DESCRIPTION	COMMENTS	QTY.
	133004	Assembly, Electrical Box Mount	Beginning rev. B1.01 per ECN 38420	1
1	F05004-206	Bolt, M6-1.0x16mm SHCS		7
2	F05026-1	Washer, M6 Flat Class 4		7
3	133005	Bracket, Lower Cover		1
4	F05026-4	Washer, M8 Flat		10
5	F05021-33	Screw, M8-1.25x25 SHC BO		10
6	133006	Bracket, Upper Cover		1
7	F05010-132	Nut, M8-1.25 Hex Nylock		4
8	133003	Weldment, Electric Box		1

6.8 Electrical Box Mount (rev B1.00)

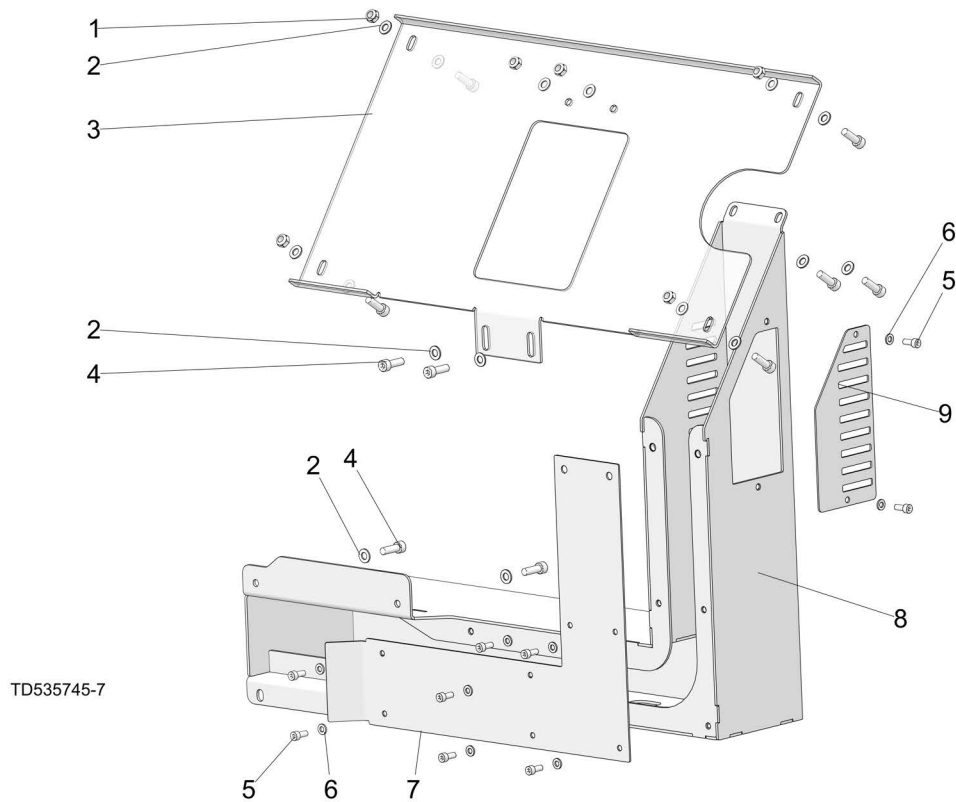

REF	PART #	DESCRIPTION	COMMENTS	QTY.
	535715-US	Assembly, Electrical Box Mount Complete	Used until rev. B1.01 changed by ECN 38420	1
1	F05010-132	Nut, M8-1.25 Hex Nylock		6
2	F05026-4	Washer, M8 Flat		18
3	533713-1-US	Bracket, Electric Box Plate		1
4	F05021-33	Screw, M8-1.25x25 SHC BO		12
5	F05004-206	Screw, M6-1.0 x 16mm SHCS		9
6	F05026-1	Washer, M6 Flat Class 4		9
7	535714-1-US	Bracket, Cover		1
8	535640-1-US	Weldment, Electric Box Mount		1
9	537669-1-US	Plate, Cover Small		1

6.9 Electrical Control Panel

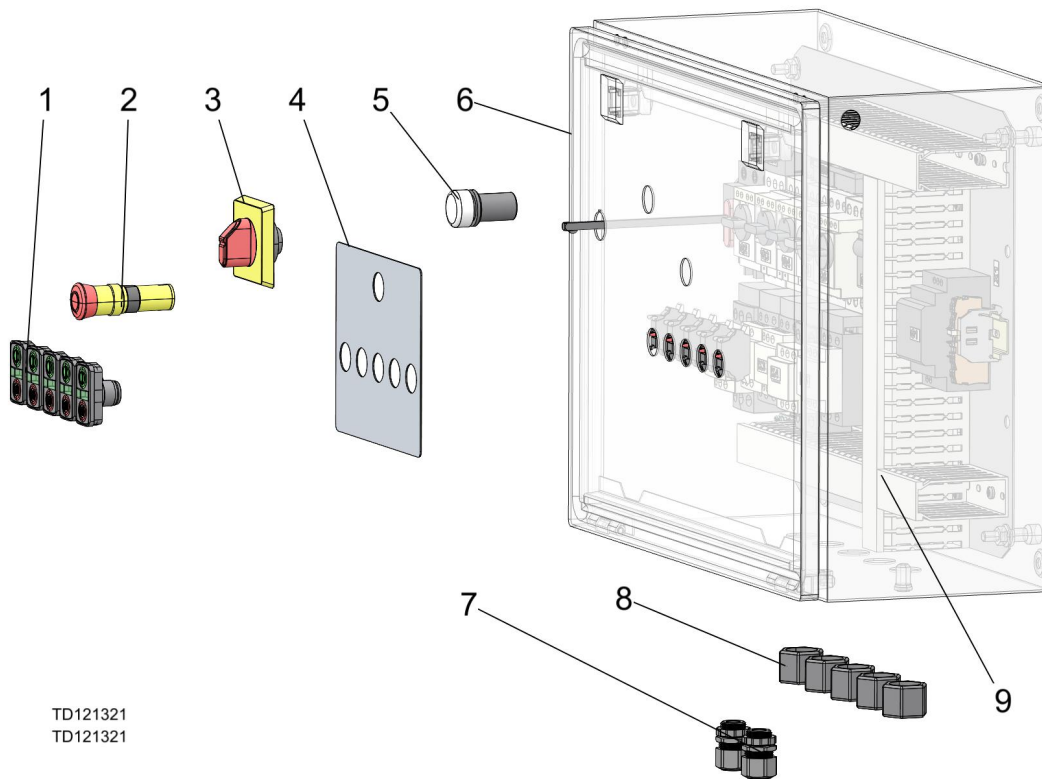

REF	PART #	DESCRIPTION	COMMENTS	QTY.
	121321	Assembly, Enclosure, MP360, 240V 3ph	Beginning rev. B1.01 per ECN 38420	1
1	068909	Push Button, Grn/Red Marked Flush		5
2	121143	E-Stop, Red, Monoblock, 1NC, Mushroom		1
3	050883-1	Handle, Disconnect RED/YEL 6mm Shaft		1
4	121167	DECAL, CONTROL, MP260		1
5	068321	Pilot Light, 24V White LED Monoblock		1
6	121323	Enc, Modified, MP360		1
7	069753	Connector, M20 0.17-0.45 Cord Grip		2
8	068303	Cord Grip, M25 0.485-0.709" Black		5
9	121322	Assy, PNL, MP360, 240V, 3Ph	See <i>Electrical Information -MP360BU rev B1.01 (US)</i> for more information.	1

6.10 Insert Panel (rev A1.00)

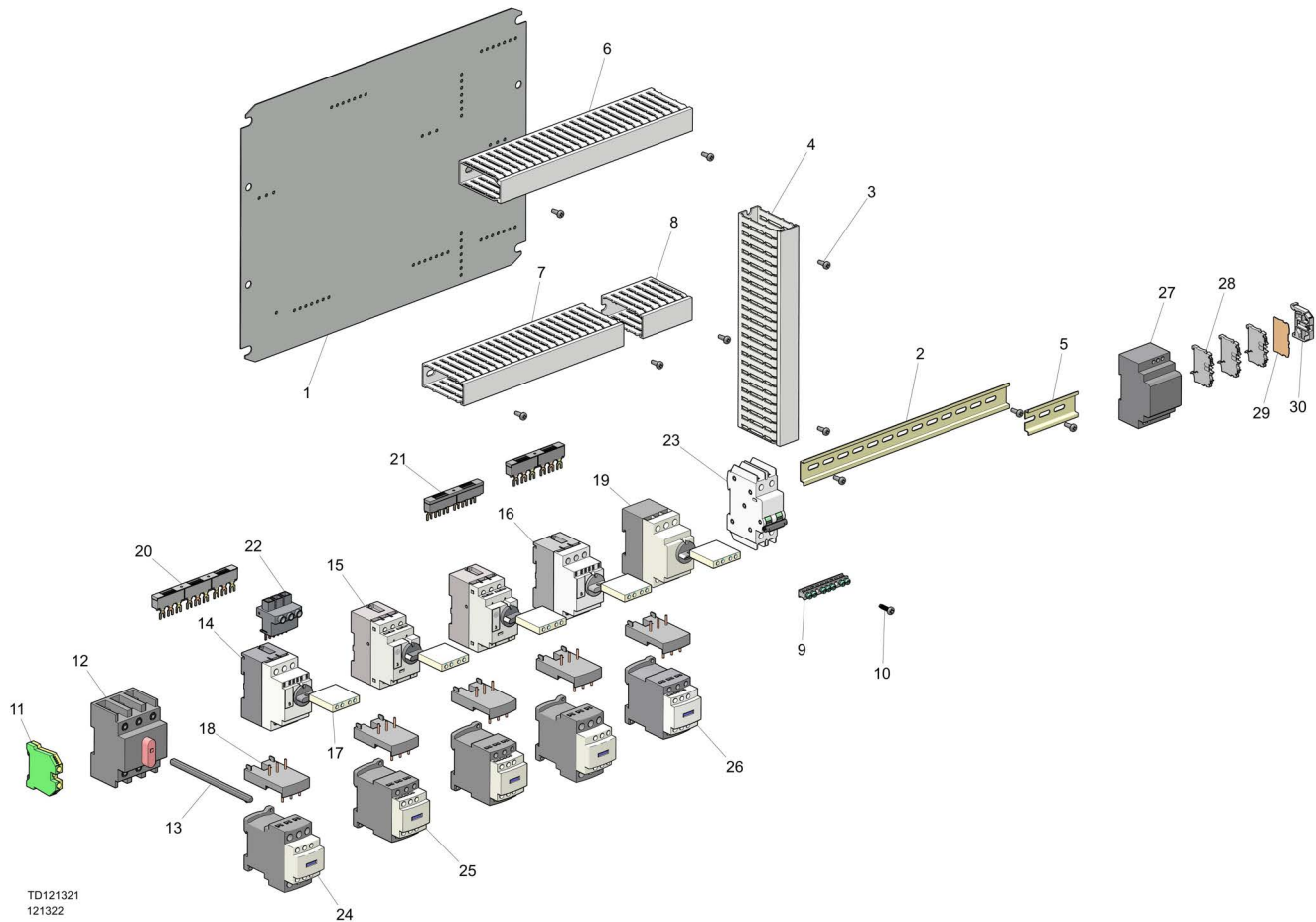

REF	PART #	DESCRIPTION	COMMENTS	QTY.
	121322	Assembly, PNL, MP360, 240V, 3Ph		1
1	121322-1	Insert PNL, Modified, MP360		1
2	024474_13_5	DIN RAIL, 13.5 LG		1
3	F05015-17	Bolt, #10-24x1/2 PH		10
4	050735_11_625	Cable Duct, 3H x 1W x 11.625L Open Slot WHT		1
5	024474-3_25	DIN RAIL, 35MMX7.5MMX3.25IN STEEL SYM		1
6	050735_12_625	Cable Duct, 3H x 1W x 12.625L Open Slot WHT		1
7	050735_10_5	Cable Duct, 3H x 1W x 10.5L Open Slot WHT		1
8	050735_3_25	Cable Duct, 3H x 1W x 3.25L Open Slot WHT		1
9	121324	Bar, Grounding 14 Circuit W/Lug		1
10	F05015-42	Screw, #10-24x3/4 Ph Pan Hd, Type 23		1
11	052525	Terminal Block, 4ga GND		1
12	050906-1	Disconnect, 100A 3Ph Non-Fused-6mm Shaft		1
13	051673-1_5_85	Shaft, Disconnect 5.85in		1
14	068583	Motor Protector, 13-18A Manual		1
15	121178	Motor Protector, 9-14A Manual		2
16	121142	Motor Protector, 17-23A Manual		1

REF	PART #	DESCRIPTION	COMMENTS	QTY.
17	068361	Contact Block, 1NO 1NC GV2		5
18	068099	Motor Protector, Interconnect LC1D09-25		5
19	102501	Motor Protector, 2.5-4.0 Manual		1
20	535506	Bussbar, 3Pos, 45mm Pitch, 63A		1
21	535502	Bussbar, 2 Pos., 45mm Pitch, 63A		2
22	078586	Motor Protector, Bussbar Terminal Block		1
23	533794	Breaker, 2A 2P C Curve UL489		1
24	069866	Contact, 25A 3P 24V Low Pwr Coil		2
25	024911	Contact, 18A 3 Pole 24V Low Pwr Coil		2
26	024890	Contact, 9A 3P 24VDC Coil		1
27	114017	Power Supply, 60W 24VDC	Move parts 28-30 over when 515294 (smaller version of Power Supply) is being replaced	1
28	068100	Terminal Block, 2Pos 1.5mm Clamp		3
29	068102	Terminal Block, 2Pos 1.5mm End Plate		1
30	051986	Din Clamp, Screwless		1

6.11 Control Box (rev B1.00)

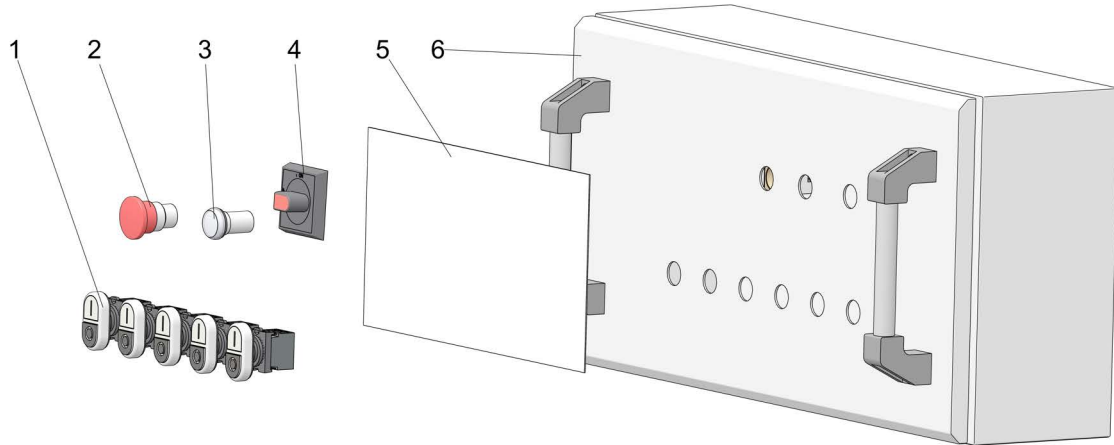

TD535745-8

REF	PART #	DESCRIPTION	COMMENTS	QTY.
	532800-2U-US	Assembly, Electric Box MP360EB	Used until rev. B1.01 changed by ECN 38420	1
1	532796	Switch Xb5aw331 M5 5		5
2	502315	Button, Emergency Stop		1
3	519612	Light, Xb7ev7bp White Control		1
4	502312-1	Knob, Ohb S2a1 Abb Switch		1
5	539447	Decal, MP360 Control Panel		1
6	532842	Electrical Box MP360	See <i>Electrical Information - WIND Manufactured - MP-360BU revA</i> for more information.	1

SECTION 7 DECALS

7.1 Decals MP360

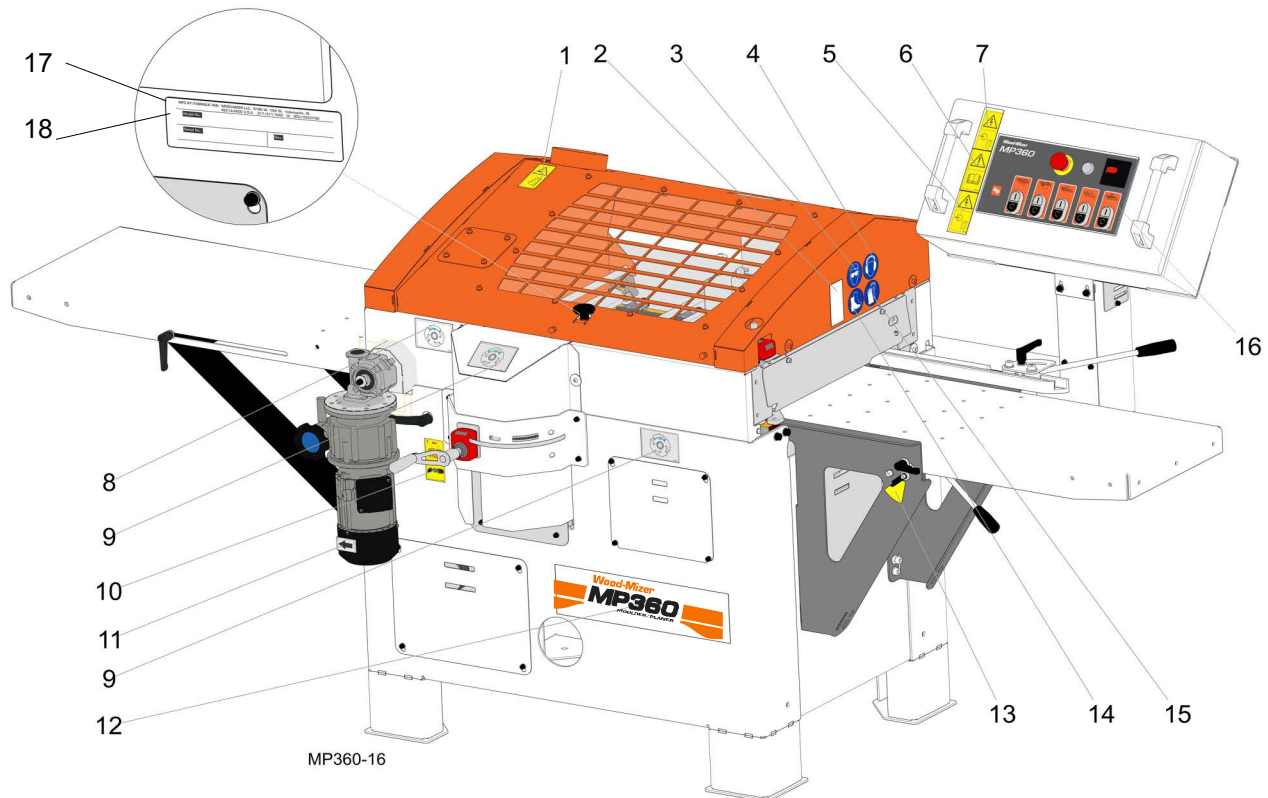

REF	PART #	DESCRIPTION	COMMENTS	QTY.
	130968	DECAL KIT, MP360		1
1	099220	Decal, Close Guards Before Operating		1
2	099221	Decal, Keep A Safe Distance		2
3	S12004G	Decal, Eye Warning		1
4	S12005G	Decal, Ear Warning		1
5	096319	Decal, Disc. Pwr Supply Before Opening		1
6	096317	Decal, Read Manual Before Operating		1
7	096316	Decal, High Voltage In Electric Box		1
8	539444-US	Decal, Shaft Rotation Direction		2
9	536401-US	Decal, Shaft Rotation Direction		2
10	535252-US	Decal, Use Only When Feed Is On		1
11	S20097	Decal, Motor Direction		1
12	539445	Decal, MP360 Planer		1
13	537504	Decal, Angular Scale		1
14	501465	Decal, Use Safety Boots		1
15	512107	Decal, Hand Protection		1
16	539477	Decal, Control Panel MP360		1
17	015820	Decal, ID Serial No.		1
18	P09971	Decal, VIN Overlay (on top of ID decal)		1