

## **APPENDIX A D24 ELECTRICAL INFORMATION**

**LX150**

**Rev. A3.02+**

# Device Tag/Parts List

Device tag	Function	Wood-Mizer Part Number	Wood-Mizer Description	Qty.	X-Ref
CB1	P/F Motor breaker	024256	Circuit Breaker, 50A	1	3.309
CB2	Up/Down Motor Breaker	024256	Circuit Breaker, 50A	1	2.205
CB3	Key Switch ST Terminal Breaker	E20430	Breaker, 15A Manual Reset	1	3.311
CB4	U/D Drum / DB In_Out Breaker	053464	Breaker, 10A Manual Reset	1	2.209
CB5	Key Switch IGN Terminal Breaker	E20430	Breaker, 15A Manual Reset	1	1.105
CB6	Key Switch ST Terminal Breaker	E20430	Breaker, 15A Manual Reset	1	1.106
CB7	Debarker Enable Breaker	E20430	Breaker, 15A Manual Reset	1	3.314
CB8	Debarker Motor Breaker	024256	Circuit Breaker, 50A	1	3.315
D1	Diode OR	069678	Wire Assembly, Up_Dn Brake Diode OR	1	1.117
D4	Diode Assy, Solenoid Coil	015426	Diode Assy, Solenoid Coil Chassis GND	2	1.114;2.206
D5	=	015426	Diode Assy, Solenoid Coil Chassis GND	2	1.116;2.209
F1	Key Switch Fuse	052370-060	MEGA Fuse 60A	1	1.101
F2	Starter Fuse	052370-150	MEGA Fuse 150A	1	1.102
G1	Battery	P12315	Battery, 12V 24M-7 (8800MF)	1	1.101
J1	Engine Harness Connector	069688	Connector, Deutsch 6P Male DT Series	1	1.106
J1	=	069689	Wedgelock, Deutsch 6P Male DT Series	1	1.106
J1	=	053429	Terminal, 16AWG Sz 16 Male Solid Deutsch Pin Gold	3	1.106
KS1	Key Switch	P04350	Switch, key	1	1.107
M3	Up/Down Motor	006747	0.50 HP DC Motor	1	2.208
M4	Feed Motor	006747	0.50 HP DC Motor	1	3.307
M5	Debarker Motor	053683	0.75 HP DC Motor	1	3.315
R1	Feed Rate Switch	024450	Pot Assy, Feed Rate Control Sawmill	1	3.303
S1	Feed Drum Switch	E20439	Drum Switch, P/F	1	3.307
S2	Up/Down Drum Swich;Up/Down Drum Swit	E20440	Drum Switch, U/D	2	1.118;2.207
S5	Blade Guide Arm Switch	024200	Switch, DPDT Toggle 21A Rev Mom Spade	1	1.109
S21	Debarker In/Out Switch - NC contact type	024200	Switch, DPDT Toggle 21A Rev Mom Spade	1	3.319
SOL4	Solenoid, 200A DPST	015417	Solenoid, 200A 12V DPST Cont. Duty	2	1.114;2.206
SOL5	=	015417	Solenoid, 200A 12V DPST Cont. Duty	2	1.116;2.209
U1	SimpleSet H-Bridge Assembly	053373	Bridge, SS	1	1.114
U2	SimpleSet Controller	053774	Controller, SimpleSet	1	1.116
U3	SimpleSet Encoder Assembly	074021	Encoder Assy, SimpleSet	1	1.116
V1	Power Feed Module	073547	Module, Consolidated P/F	1	3.304

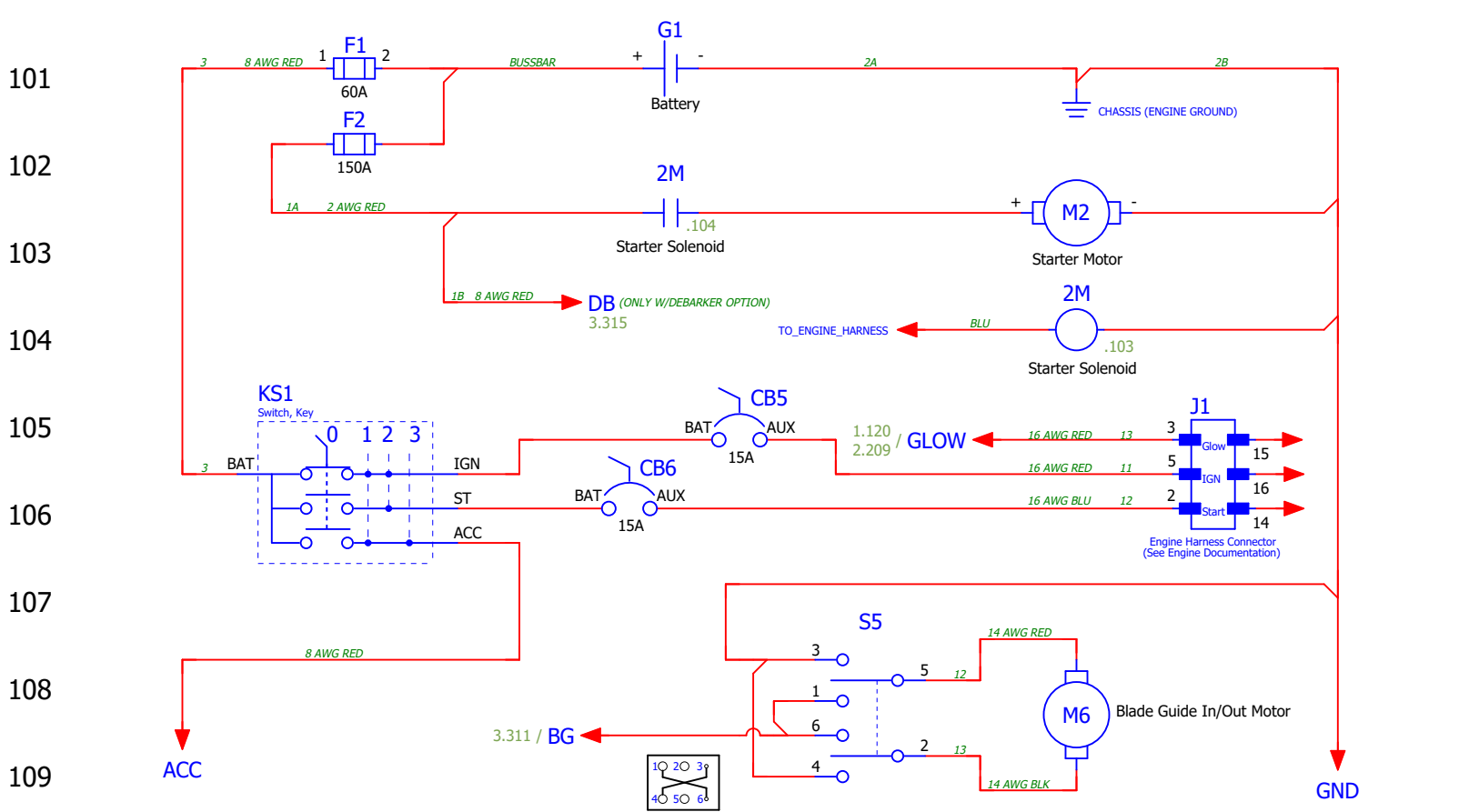

Equipped with SimpleSet

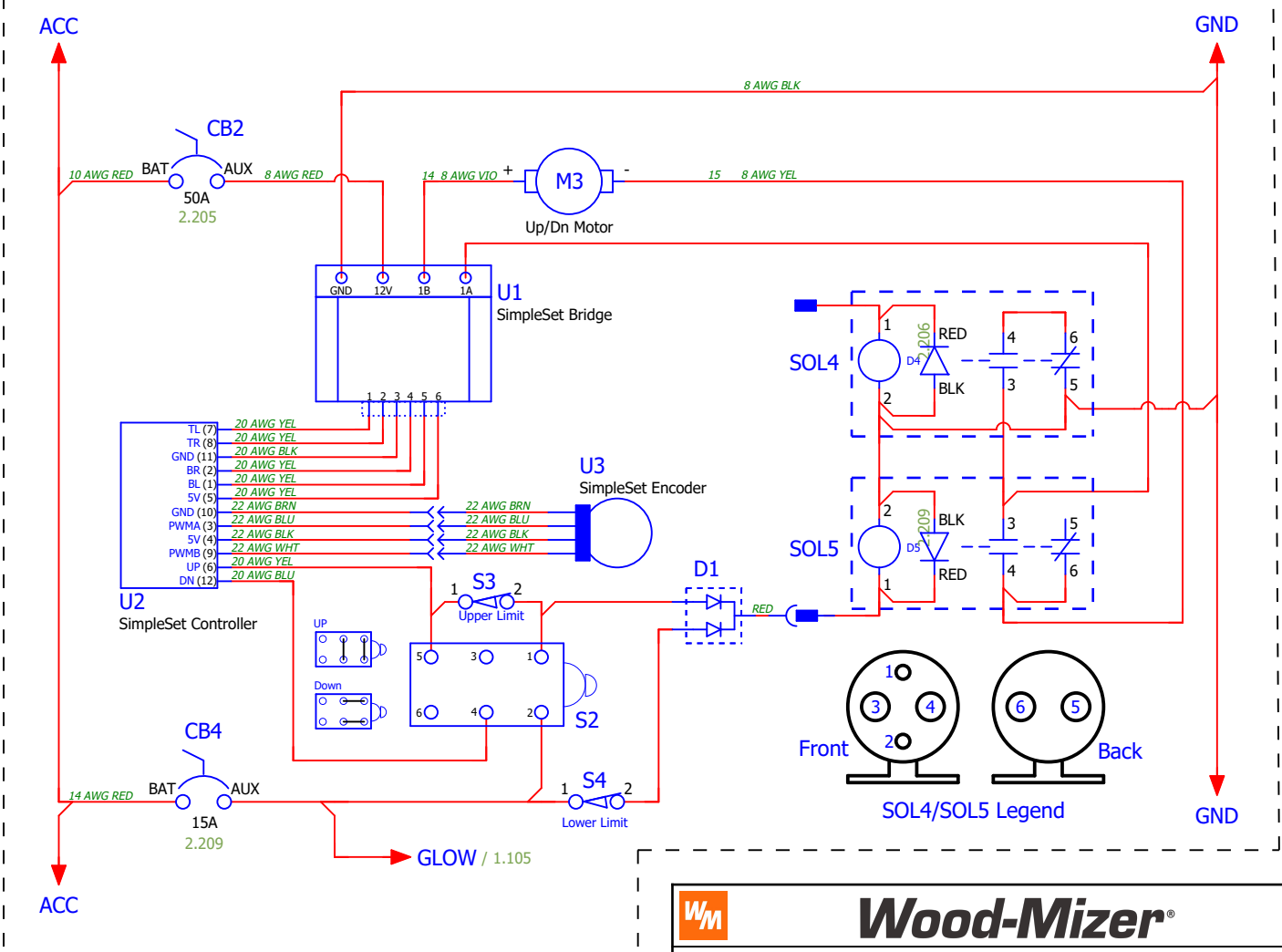

201  
202  
203  
204  
205  
206  
207  
208  
209  
210  
211  
212  
213  
214  
215  
216  
217  
218  
219  
220  
221

Without SimpleSet Option

