

**LX150 Debarker
Safety, Operation,
Maintenance, & Parts Manual**

LX150 Debarker rev.A1.00 - A1.00

Safety is our #1 concern!

September 2019

Form #2408



WARNING! Read and understand this manual before using this machine.

California
Proposition 65 Warning



WARNING: Breathing gas/diesel engine exhaust exposes you to chemicals known to the State of California to cause cancer and birth defects or other reproductive harm.

- Always start and operate the engine in a well-ventilated area.
- If in an enclosed area, vent the exhaust to the outside.
- Do not modify or tamper with the exhaust system.
- Do not idle the engine except as necessary.

For more information go to **www.P65warnings.ca.gov**.



WARNING: Drilling, sawing, sanding or machining wood products can expose you to wood dust, a substance known to the State of California to cause cancer. Avoid inhaling wood dust or use a dust mask or other safeguards for personal protection.

For more information go to **www.P65Warnings.ca.gov/wood**.

Active Patents assigned to Wood-Mizer, LLC

Wood-Mizer, LLC has received patents that protect our inventions which are a result of a dedication to research, innovation, development, and design. Learn more at: woodmizer.com/patents

©2021 Wood-Mizer LLC

Printed in the United States of America, all rights reserved. No part of this manual may be reproduced in any form by any photographic, electronic, mechanical or other means or used in any information storage and retrieval system without written permission from

Wood-Mizer, LLC
8180 West 10th Street
Indianapolis, Indiana 46214

Table of Contents

Section-Page

SAFETY

1.1	Safety Symbols.....	1-4
-----	---------------------	-----

INSTALLATION

1.1	Torque Values	1-5
1.2	Assemble Debarker	1-6
	<i>Assemble Mounting Plate.....</i>	<i>1-6</i>
	<i>Mount the Solenoid Assembly</i>	<i>1-7</i>
	<i>Mount the Cutter Motor</i>	<i>1-8</i>
1.3	Install the motor harnesses	1-8
1.4	Solenoid wiring	1-12
1.5	Control box harness installation	1-18

ALIGNMENT

1.1	Align the Debarker to the Sawblade.....	1-22
	<i>Horizontal Alignment.....</i>	<i>1-22</i>
	<i>Vertical Alignment</i>	<i>1-25</i>

OPERATION

1.1	Locking Pin Operation	1-26
1.2	Control Overview	1-26
1.3	Operation	1-27
1.4	Maintenance	1-29
1.5	Troubleshooting.....	1-30

ELECTRICAL

1.1	Components	1-32
1.2	Wiring diagram.....	1-33

PARTS

2.1	Debarker Assemblies.....	2-1
2.2	Pivot Head	2-2
2.3	Debarker Solenoid Assembly	2-4
2.4	Debarker Arm.....	2-5
2.5	Debarker Swing Arm and Stop Bracket	2-7
2.6	Cutter Head Assembly.....	2-8

SECTION 1 SAFETY

1.1 Safety Symbols

The following symbols and signal words call your attention to instructions concerning your personal safety. Be sure to observe and follow these instructions.

 **DANGER!** indicates an imminently hazardous situation which, if not avoided, will result in serious injury or death.

 **WARNING!** suggests a potentially hazardous situation which, if not avoided, could result in serious injury or death.

 **CAUTION!** refers to potentially hazardous situations which, if not avoided, may result in minor or moderate injury or damage to equipment.

NOTICE indicates vital information.

 **WARNING!** Turn the base unit's power to OFF, remove the key, and disconnect the battery ground terminal, if applicable.

On electric equipment, lock out power supply before performing any installation. See Electrical Lockout Procedures (OSHA regulation 1910.147, appendix A reprinted in the Operator's Manual).

Ensure all electrical installation, service, and/or maintenance is performed by a qualified electrician.

Ensure your unit is on a level surface and secure from movement.

SECTION 1 INSTALLATION



WARNING! Turn the base unit's power to OFF, remove the key, and disconnect the battery ground terminal, if applicable.



On electric equipment, lock out power supply before performing any installation. See Electrical Lockout Procedures (OSHA regulation 1910.147, appendix A reprinted in the Operator's Manual).

Ensure all electrical installation, service, and/or maintenance is performed by a qualified electrician.

Ensure your unit is on a level surface and secure from movement.

1.1 Torque Values

Use these torque values on this unit unless otherwise specified.

Grade		Units	SAE 5	SAE 8
Grade Mark				
Bolt Dia.	Threads Per In.	Units	SAE 5	SAE 8
6	32	in-lbs (Nm)	20 (2.3)	-
8	32	in-lbs (Nm)	24 (2.7)	30 (3.4)
10	24	in-lbs (Nm)	35 (4.0)	45 (5.1)
10	32	in-lbs (Nm)	40 (4.5)	50 (5.7)
12	24	in-lbs (Nm)	50 (5.7)	65 (7.3)
1/4	20	in-lbs (Nm)	95 (10.7)	125 (14.1)
1/4	28	in-lbs (Nm)	95 (10.7)	150 (17.0)
5/16	18	ft-lbs (Nm)	17 (22.6)	23 (31.2)
5/16	24	ft-lbs (Nm)	20 (27.1)	25 (33.8)
3/8	16	ft-lbs (Nm)	30 (40.7)	40 (54.2)
3/8	24	ft-lbs (Nm)	35 (47.5)	45 (61.0)
7/16	14	ft-lbs (Nm)	50 (67.8)	65 (88.1)
7/16	20	ft-lbs (Nm)	55 (74.6)	70 (94.9)
1/2	13	ft-lbs (Nm)	75 (101.7)	100 (135.6)
1/2	20	ft-lbs (Nm)	85 (115.3)	110 (149.2)
9/16	12	ft-lbs (Nm)	105 (142.4)	135 (183.1)
9/16	18	ft-lbs (Nm)	115 (155.9)	150 (203.4)
5/8	11	ft-lbs (Nm)	150 (203.4)	195 (264.4)
5/8	18	ft-lbs (Nm)	160 (217.0)	210 (284.8)
3/4	10	ft-lbs (Nm)	170 (230.5)	220 (298.3)
3/4	16	ft-lbs (Nm)	175 (237.3)	225 (305.1)
7/8	9	ft-lbs (Nm)	302 (409.5)	473 (640.9)
7/8	14	ft-lbs (Nm)	300 (406.8)	400 (542.4)
1	8	ft-lbs (Nm)	466 (631.8)	714 (967.4)

1.2 Assemble Debarker

Assemble Mounting Plate

1. Tighten the hardware holding the mounting plate on the debarker arm. See Figure 1.

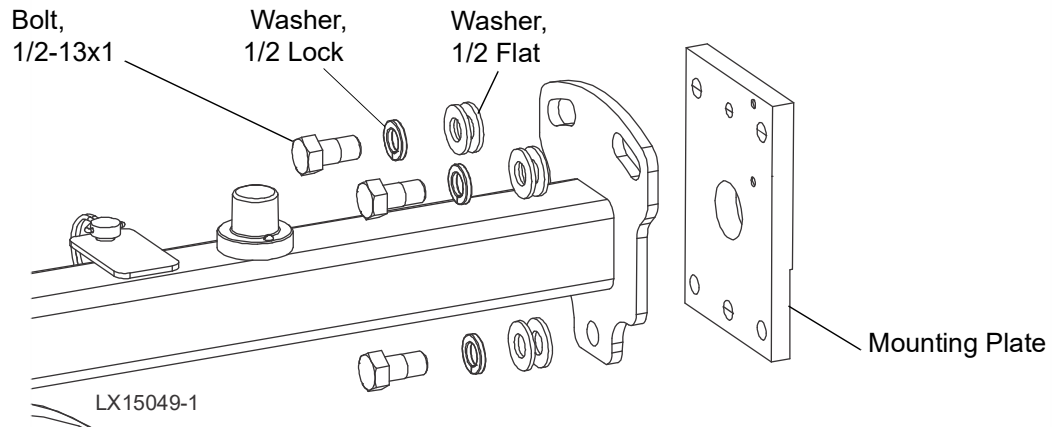

FIG. 1-1

2. Remove wire harness clamp hardware from the mounting hole on the sawhead.
3. Align the debarker hardware into the mounting holes. See Figure 1-2.

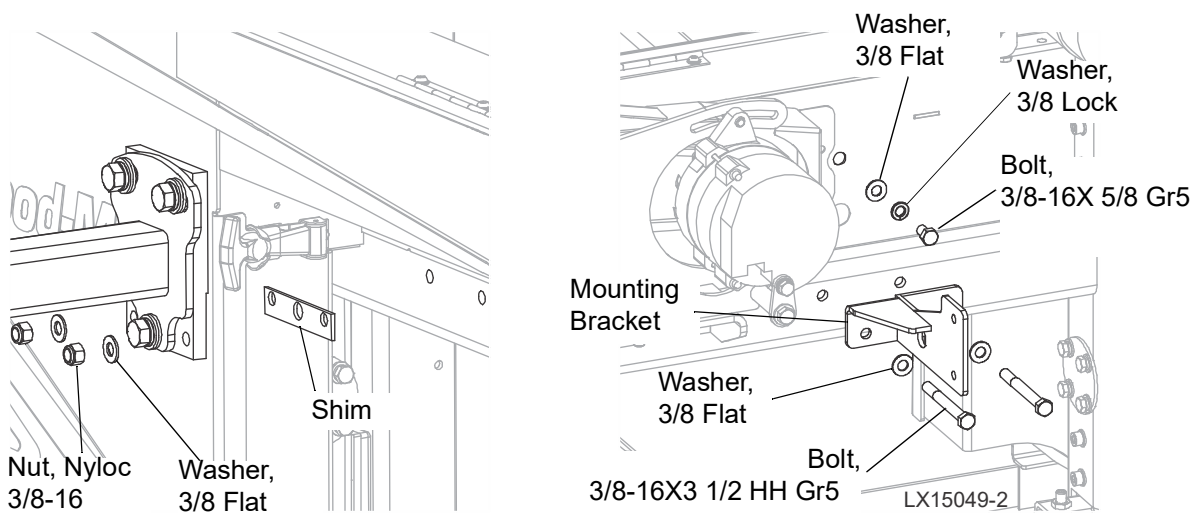

FIG. 1-2

4. Ensure the debarker is square to the sawhead before tightening.

Mount the Solenoid Assembly

1. Install the solenoid/breaker box to the mounting bracket. See Fig. 1-3.

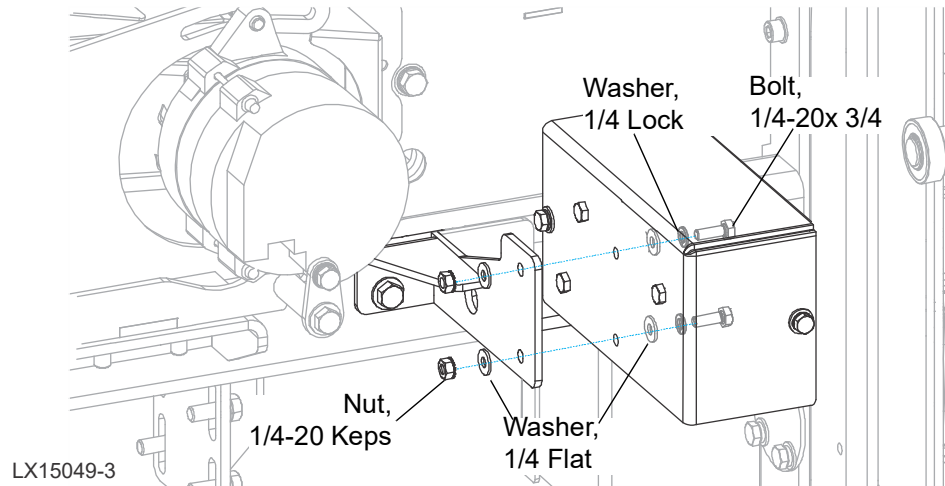

FIG. 1-3

1 Installation

Mount the Cutter Motor

Mount the Cutter Motor

1. Install the cutter head to the pivot arm mounting bracket. See Fig. 1-4.

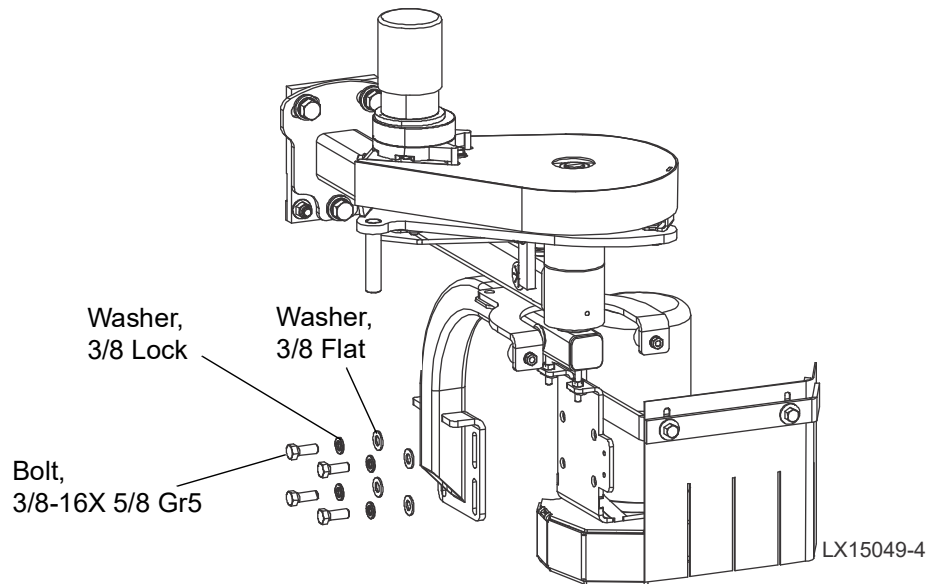

FIG. 1-4

1.3 Install the motor harnesses

NOTICE: Avoid pinch and pivot points, unnecessary wire bending, and open spaces where the wire could get caught by a log, etc.

1. Unclip the strobe light wire coming out of the debarker arm and thread it through the starred grommet from the hardware bag.

2. Install the grommets from the hardware bag into the arms as shown in Fig.1-5

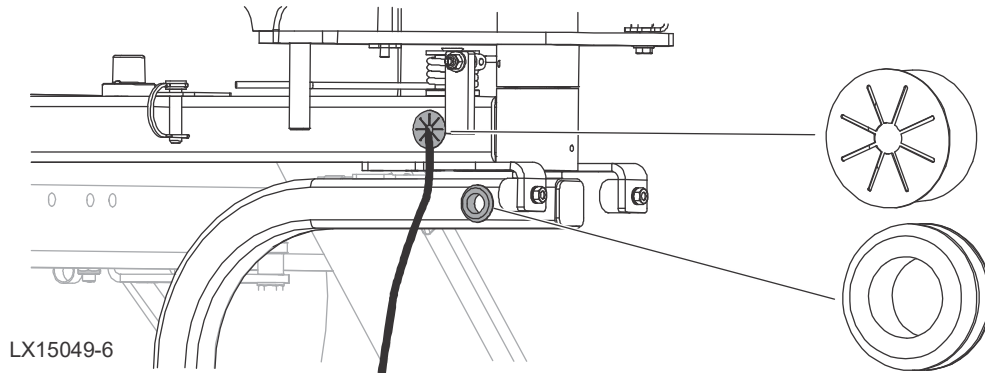

FIG. 1-5

3. Thread the rest of the strobe light wire through lower grommet and through the pivot arm.
4. Remove the cap from the cutter motor.
5. Remove the motor terminal nuts. (Set aside for reuse.)
6. Place the strobe light ring terminals over the motor terminals -- **red to positive, black to negative.** See Fig. 1-6.

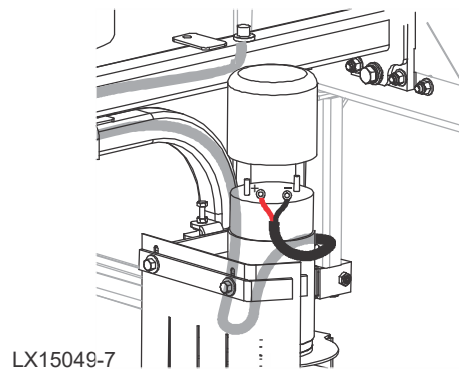

FIG. 1-6

NOTICE: The main mill wiring harness has the wires to the debarker in/out motor (#21 and 22) and the debarker solenoid coil pre-wired on it and bundled near the engine. Clip the ties and unfold the wires.

1 Installation

Install the motor harnesses

7. Route the debarker in/out motor harness through the saw head frame hole as shown in Fig. 1-7.

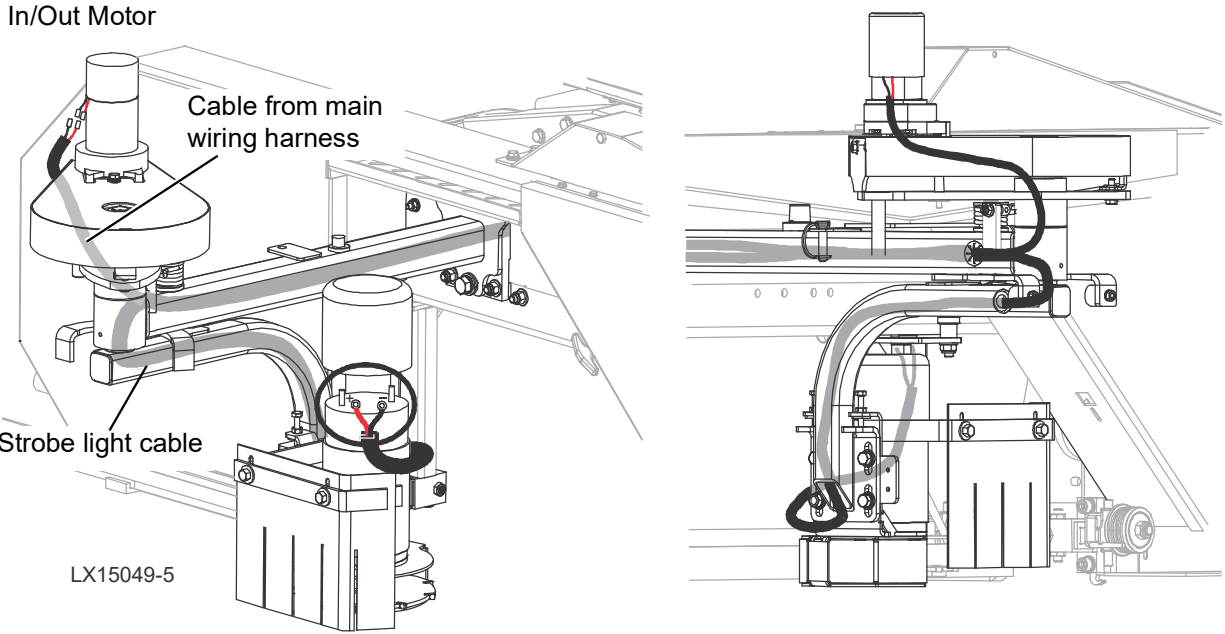
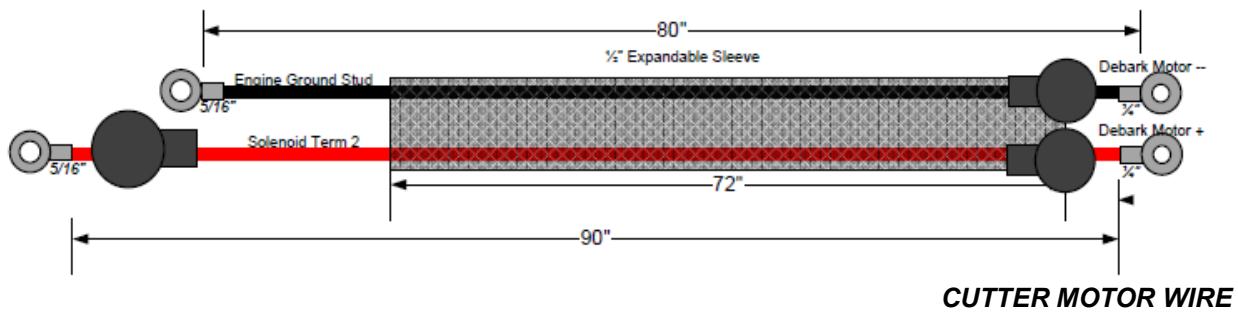

FIG. 1-7

8. Crimp the male disconnect terminals (blue) (from the hardware bag) to the motor wires.
9. Connect the in/out motor wires red-to-red and black-to-black.
10. Install the cutter motor wire (longest) from the engine area to the cutter motor.



- a. Thread the cable end with the two boots through the straight arm and the pivot arm, similar to the strobe light wire. See Fig.

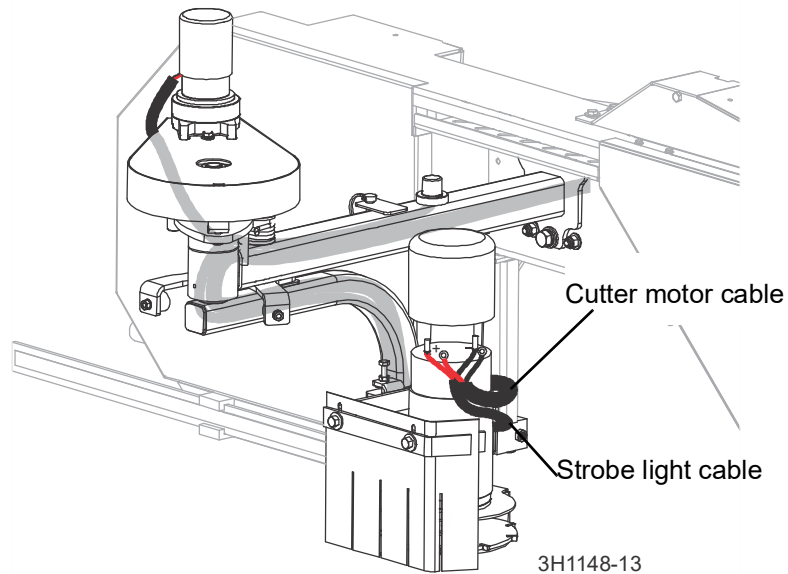

FIG. 1-8

- b. Place the ring terminals on the motor -- **red to positive, black to negative.**
- c. Replace the terminal nuts removed in step 5.

NOTICE: Ring terminals must not touch the motor.

- d. Slide the rubber boots over the motor terminal studs.
11. Replace the motor cap.
 12. Use wire ties as necessary to bundle the cables neatly.

1 Installation

Solenoid wiring

1.4 Solenoid wiring

1. Remove the solenoid/breaker box cover for easier access. See Fig.1-9.

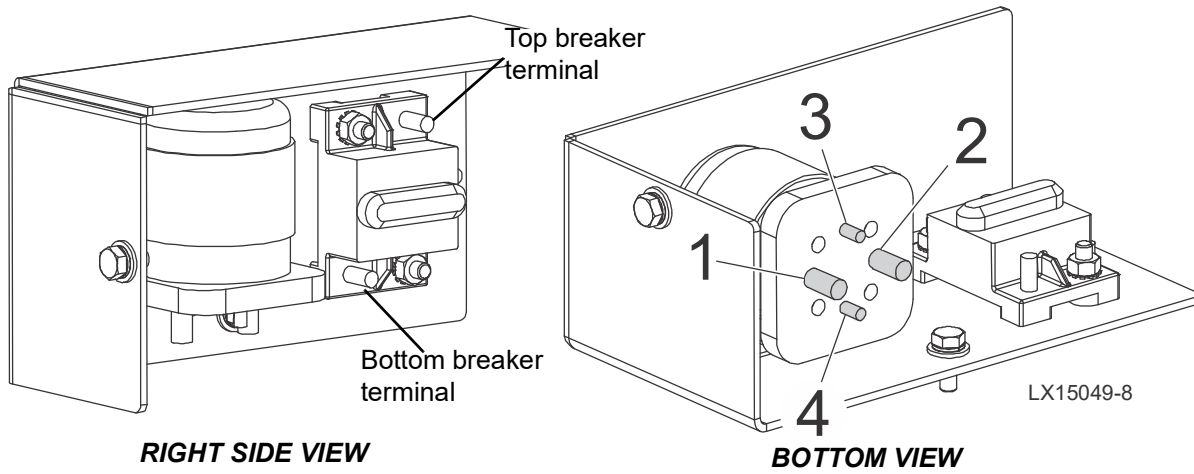

FIG. 1-9

2. Remove the nuts from the terminal posts and retain them for reinstallation.

3. From the mill's main wiring harness (located for step 6), place the remaining wire (201) on solenoid terminal 3. (See Fig. 1-10.)

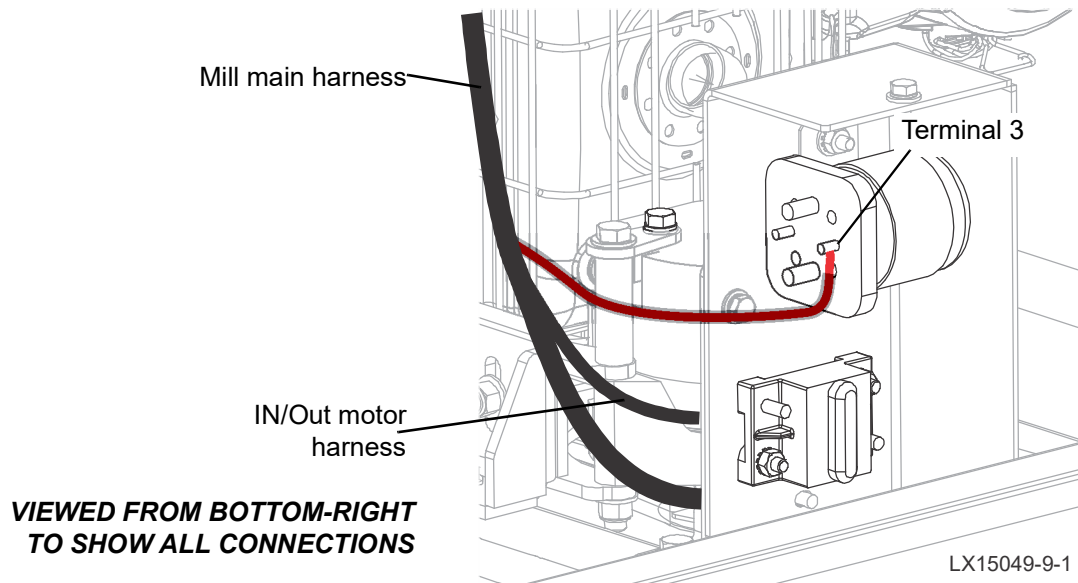

FIG. 1-10

1 Installation

Solenoid wiring

4. Connect the red 27" wire between the alternator battery terminal and the top breaker terminal. See Fig. 1-11.

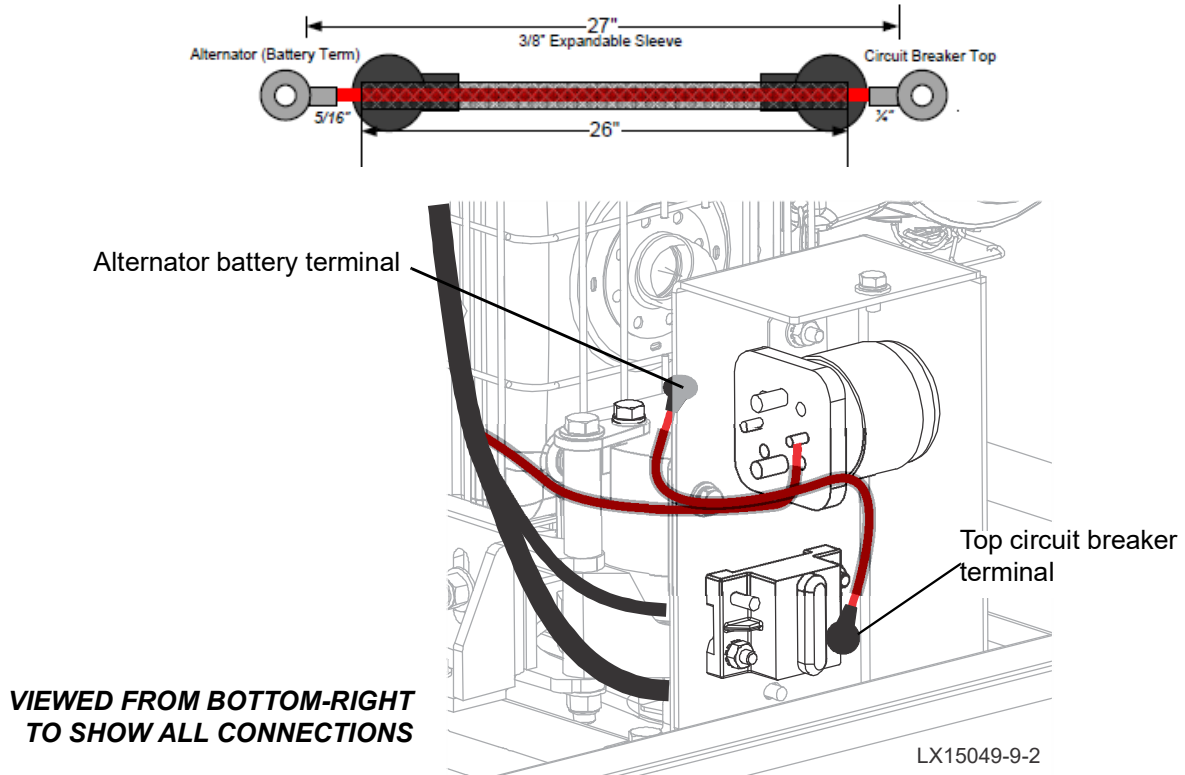

FIG. 1-11

5. Reinstall terminal nuts and slide the boot on the terminal.

6. Connect the 18" black wire between the alternator ground stud and solenoid terminal 4.

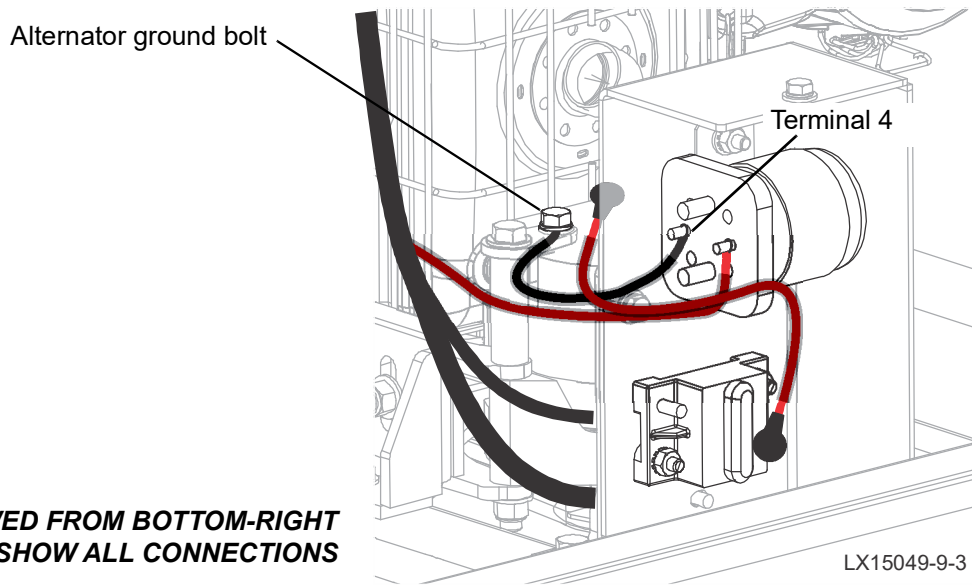
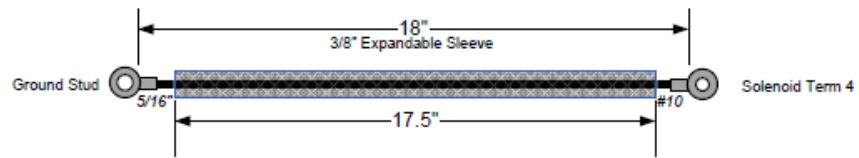
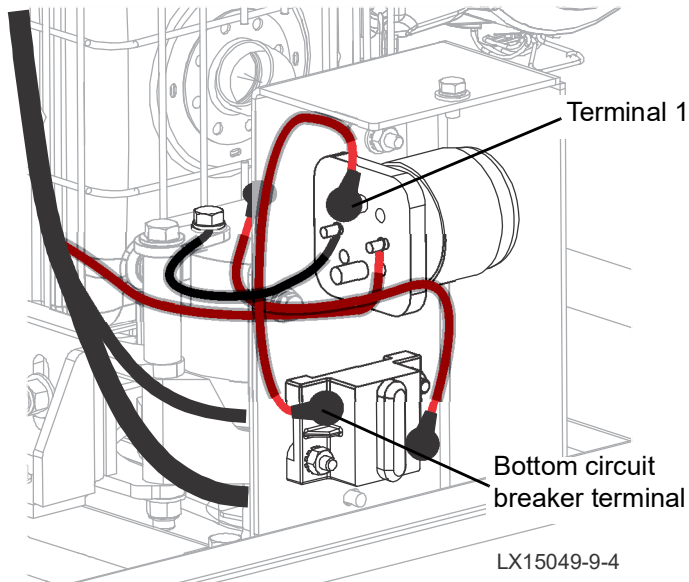
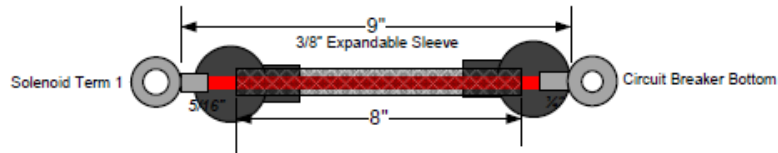

FIG. 1-12

1 Installation

Solenoid wiring

7. Connect the 9" red wire between the bottom circuit breaker and solenoid terminal 1.



**VIEWED FROM BOTTOM-RIGHT
TO SHOW ALL CONNECTIONS**

FIG. 1-13

8. Reinstall terminal nuts and slide the boots on the terminal.

9. Connect the 7" diode assembly (from the hardware bag) between solenoid terminal 3 (red end) and solenoid terminal 4 (black end).

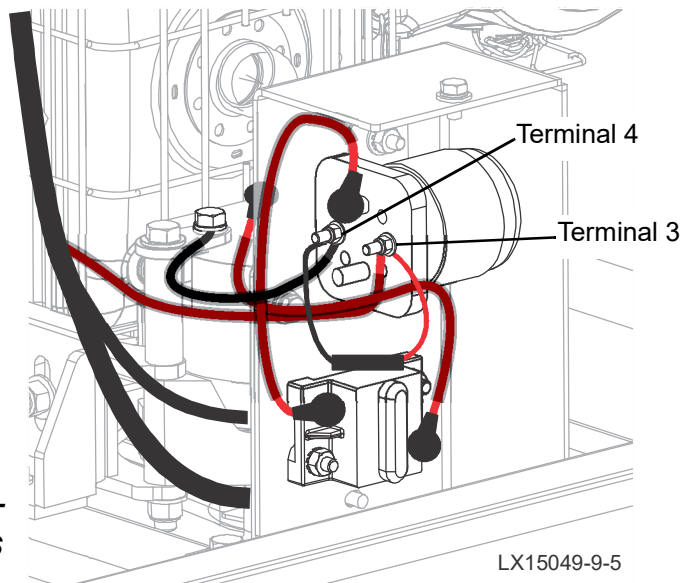
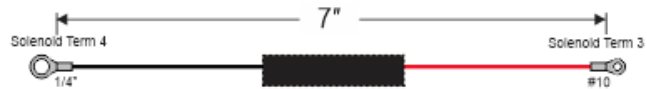

**VIEWED FROM BOTTOM-RIGHT
TO SHOW ALL CONNECTIONS**

LX15049-9-5

FIG. 1-14

10. Replace the terminal 3 and 4 nuts.

1

Installation

Control box harness installation

11. Connect the 90" cutter motor cable red wire to the solenoid terminal 2 and the black wire to the alternator ground bolt.

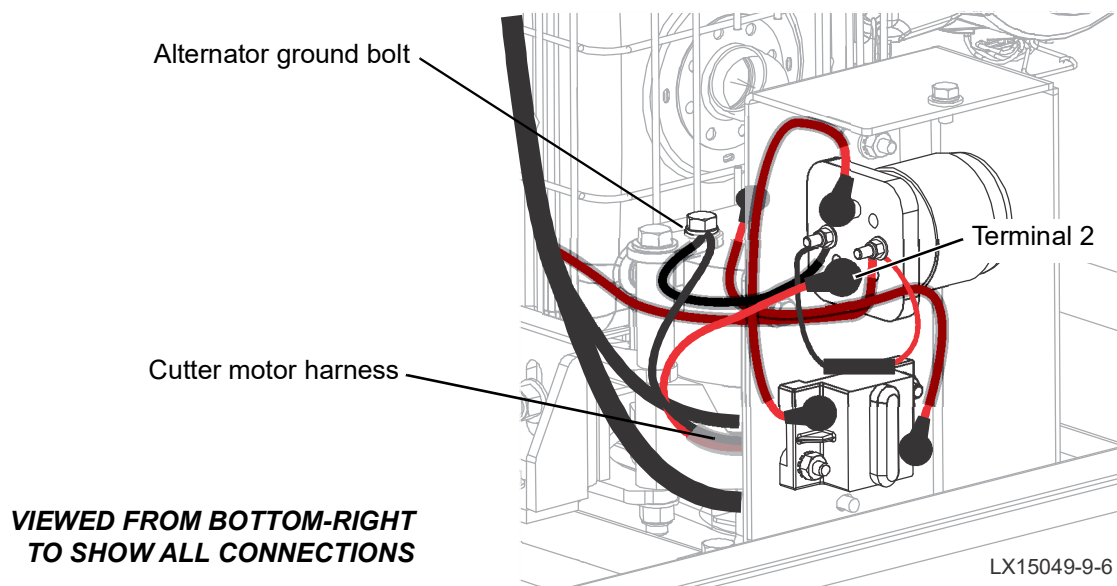
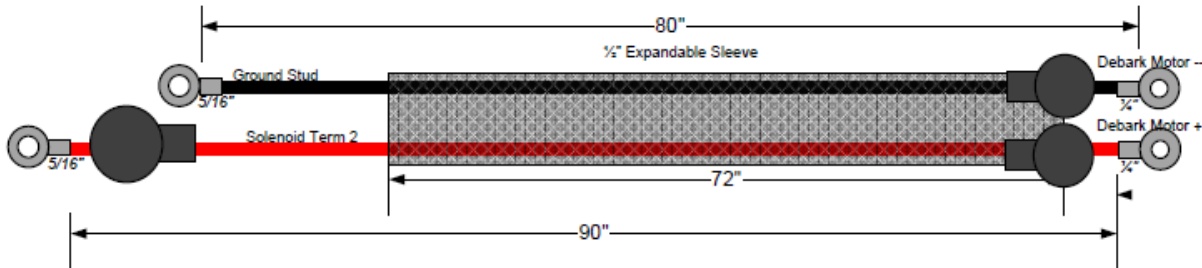

FIG. 1-15

12. Reinstall terminal nuts and slide the boots on the terminal. Tightened alternator ground bolt.
13. Check all nuts for tightness and secure protective boots over terminals.

1.5 Control box harness installation

1. Remove the front panel (**leave wires connected**) from the control box.
2. Cut out debarker on/off and in/out switch holes in the front panel decal.

3. Install the debarker on/off and in/out switches, 1/16" nylon washers, and rubber boots in place. See Fig. 1-16.

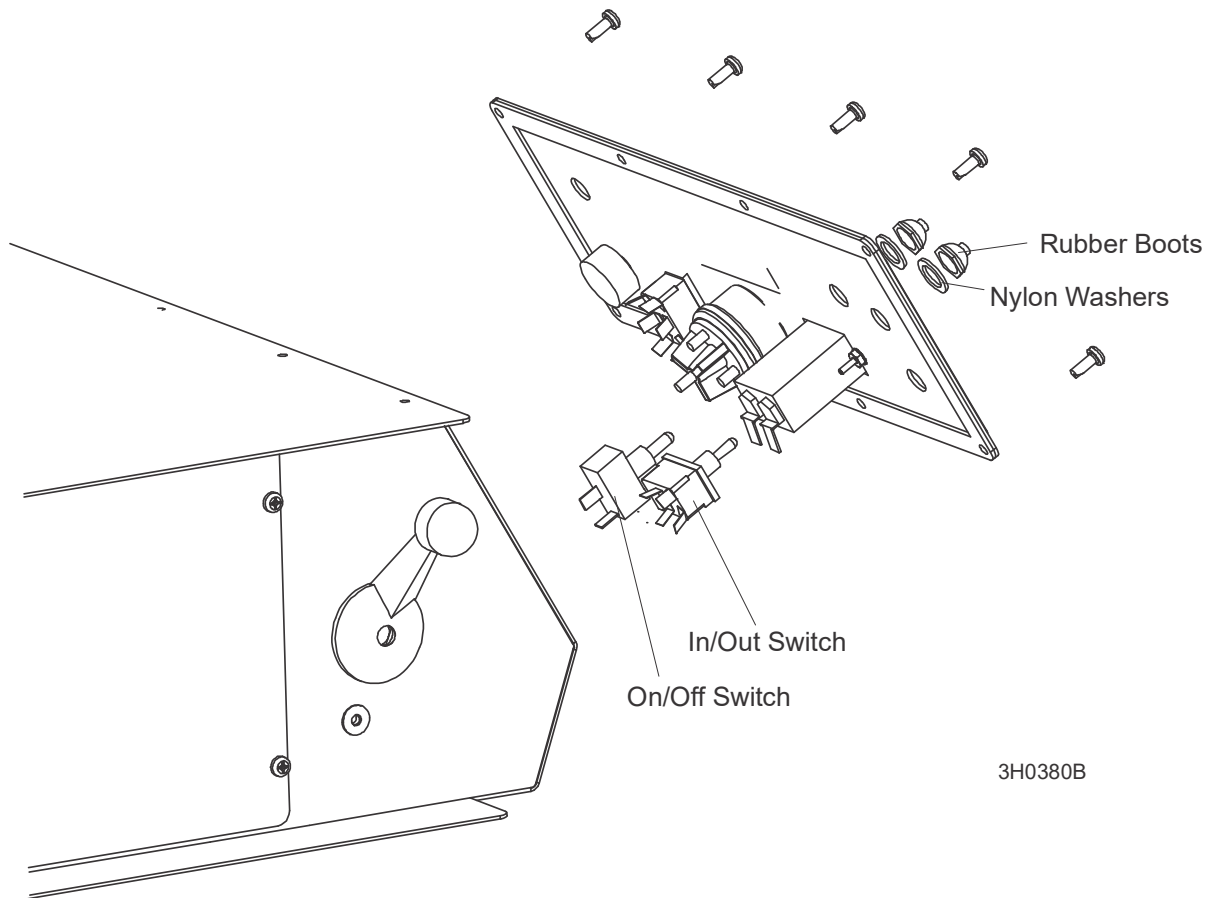

FIG. 1-16

4. Connect the red wire "200" from the AUX post of the circuit breaker CB7 to the top terminal on the debarker on/off switch.
5. Connect the red wire labeled "201" from the debarker harness to the bottom terminal on the debarker on/off switch.
6. Connect the black wire labeled "22" from the debarker harness to the top middle terminal on the debarker in/out switch.
7. Connect the red wire labeled "21" from the debarker harness to the bottom middle terminal on the debarker in/out switch.

1

Installation

Control box harness installation

8. Connect the red wire "205" from the AUX post of the circuit breaker CB3 to the top end terminal on the debarker in/out switch.
9. Connect the black wire from the ground stud to the bottom end terminal on the debarker in/out switch.
10. Reinstall the front panel to the control box.

NOTE: Only wires referred to above are shown in Fig. 1-17.

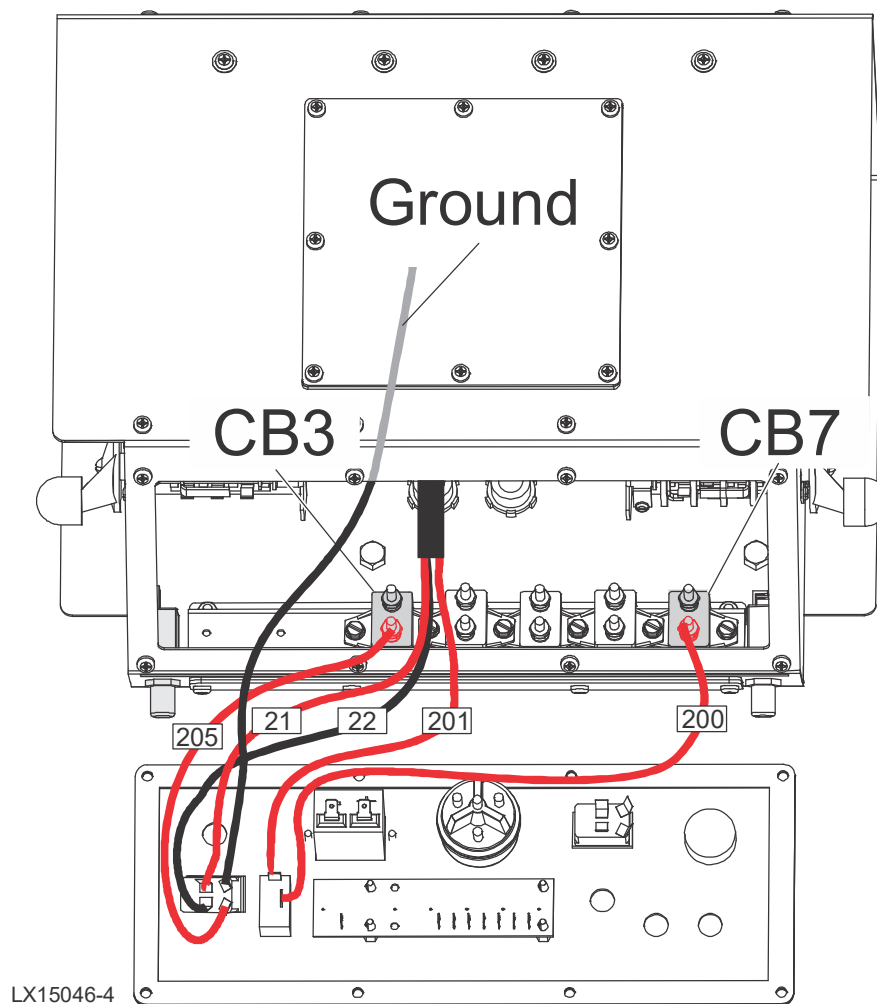

FIG. 1-17

SECTION 1 ALIGNMENT

1.1 Align the Debarker to the Sawblade

Horizontal Alignment

1. Turn the power key to ACC (3) and use the debarker in/out switch to move the debarker completely inward.



WARNING! Turn the base unit's power to OFF, remove the key, and disconnect the battery ground terminal, if applicable.

2. Clip the blade guide alignment tool (or an appropriate straight edge) to the sawmill blade.

NOTE: Ensure the tool lies flat on the blade and does not contact a tooth or burr.

3. Check the squareness of the debarker with the sawmill blade.
 - a. Mark the position of the debarker blade in relationship to the bottom of the blade guide alignment tool. (Measurement A in Fig. 1-1.)
 - b. Turn the key to ACC (3) and use the debarker in/out switch to move the debarker all the way inward.



WARNING! Turn the base unit's power to OFF, remove the key, and disconnect the battery ground terminal, if applicable.

- c. Mark the position of the debarker blade in relationship to the bottom of the blade guide alignment tool. (Measurement B in Fig 1-1.)

The debarker blade should be the same distance from the sawmill blade during the entire swing of the debarker. (Measurement A=B)

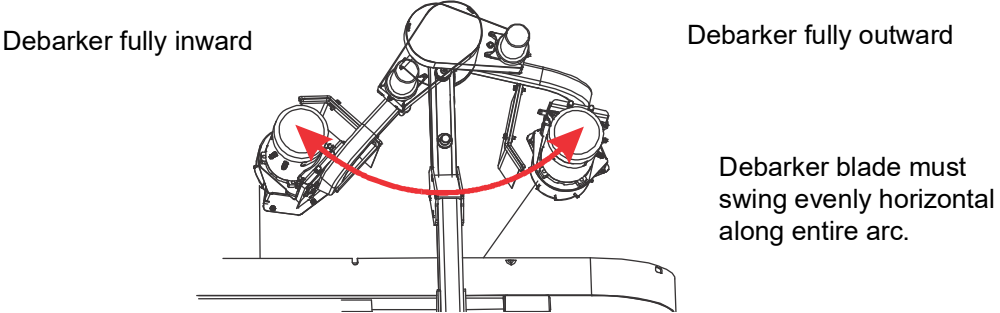

Record the distance between the sawblade and the debarker blade at both ends of the operating arc. Adjust frame until measurements are equal.

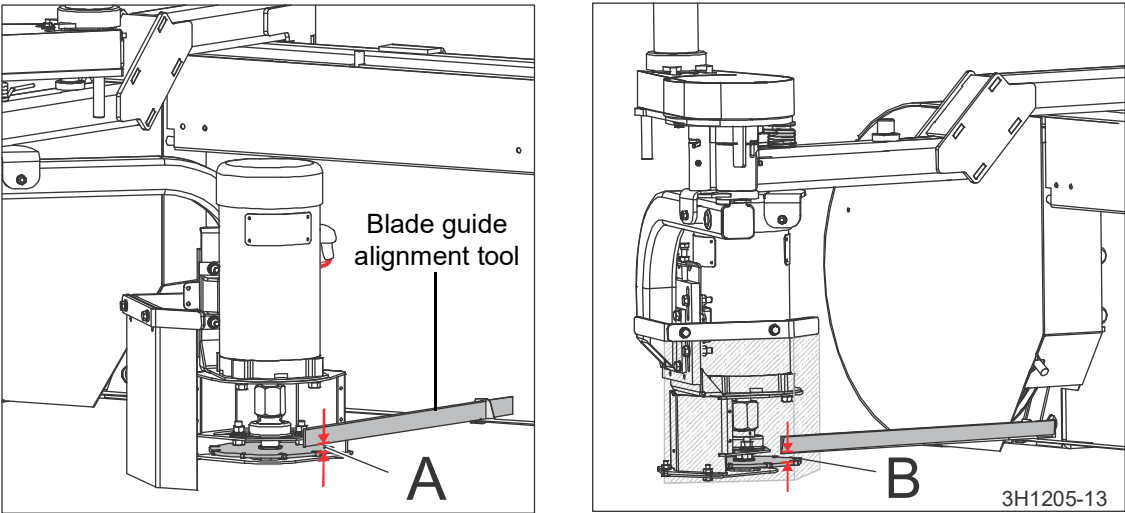

FIG. 1-1

1

Alignment

Horizontal Alignment

4. Adjust the debarker mounting bolts until debarker is square with the sawmill blade. See Fig. 1-2.

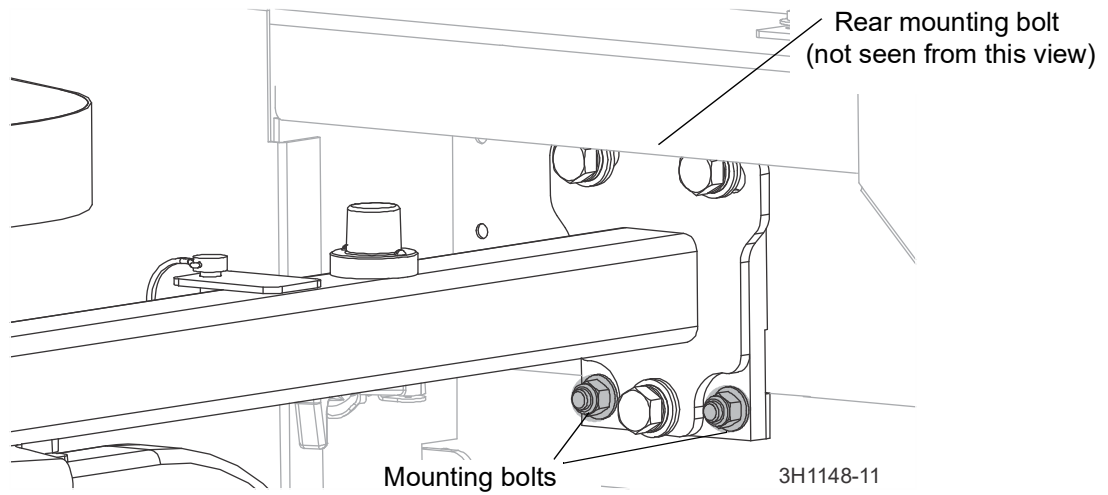
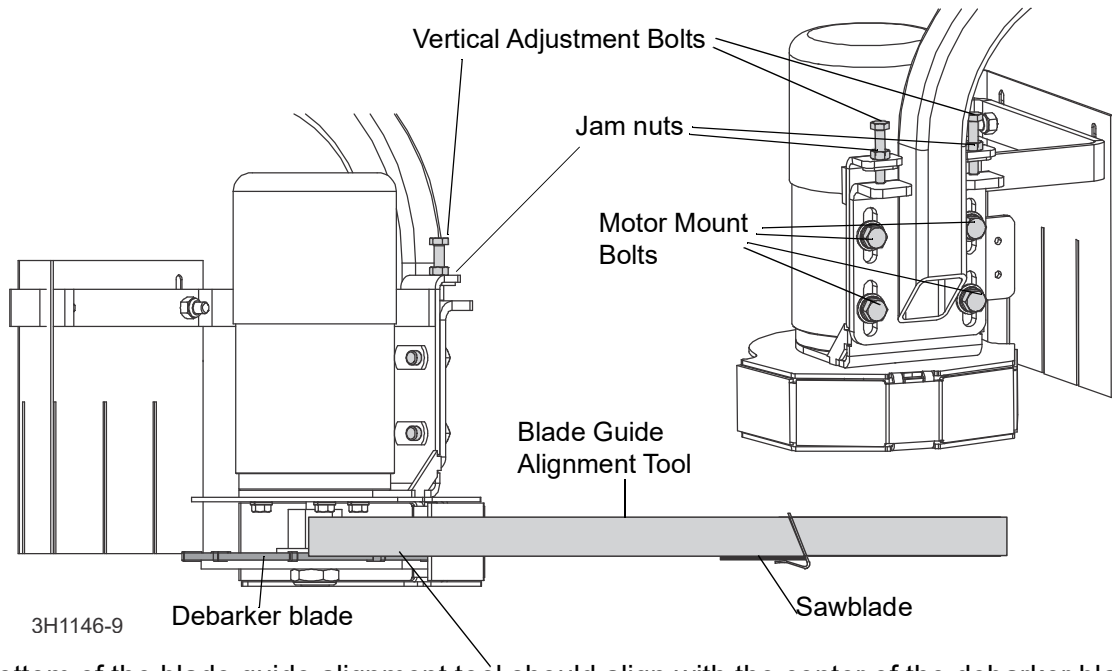

FIG. 1-2

Vertical Alignment

1. Loosen the four blade motor mount bolts. See Fig. 1-3.
2. Loosen the jam nuts on the adjustment bolts.



The bottom of the blade guide alignment tool should align with the center of the debarker blade.

FIG. 1-3

3. Turn the adjustment bolt to position the motor with blade up or down.
4. Retighten the adjustment bolt jam nut and four motor mount bolts.
5. Recheck that the debarker blade has remained parallel with the sawblade.
6. Repeat the adjustment steps until the debarker blade is **both** centered on the bottom of the blade guide adjustment tool **and** parallel to the sawmill blade.

SECTION 1 OPERATION

1.1 Locking Pin Operation



WARNING! Turn the base unit's power to OFF, remove the key, and disconnect the battery ground terminal, if applicable.

Insert the locking pin to lock the debarker in place when transporting the sawmill.

Remove the locking pin during sawing operation. See Fig. 1-0.

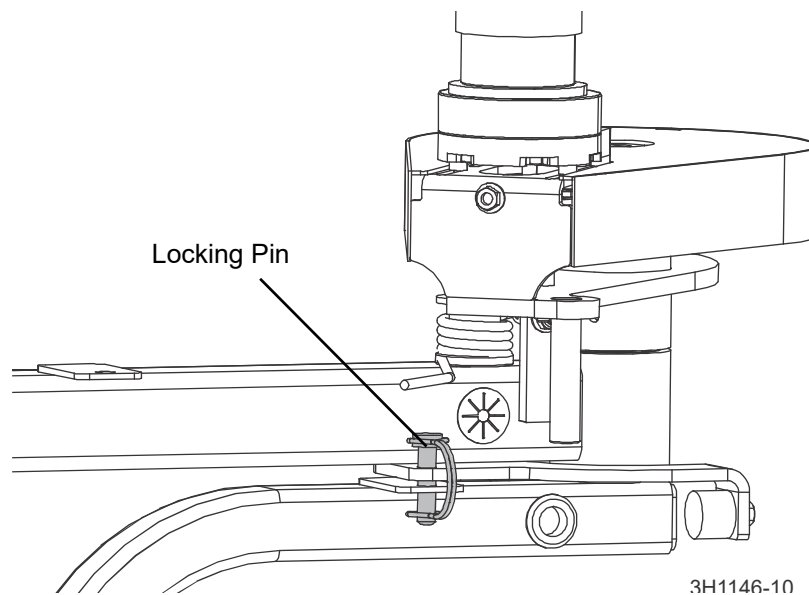

FIG. 1-0

1.2 Control Overview

The Debarker Option allows you to remove bark from logs ahead of the bandsaw blade. This prevents the bandsaw blade from contacting dirt, sand, or other debris in the bark that can dull the blade.

See Figure 1-1. The debarker control includes two toggle switches, an indicator light, and

circuit breakers with manual reset.

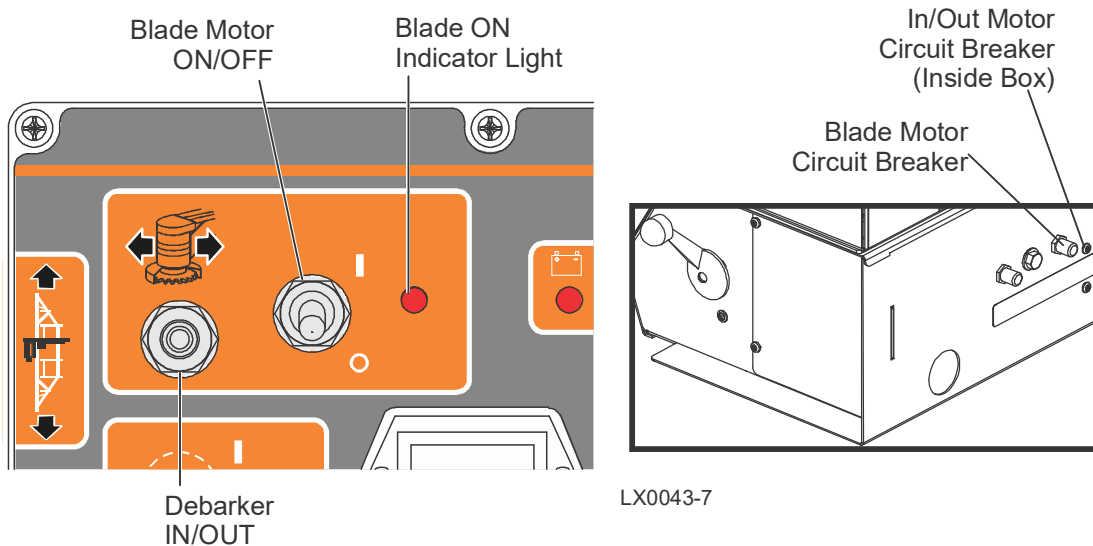



FIG. 1-1

- The Debarker IN/OUT toggle switch controls the debarker in/out motor to move the debarker cutting head toward or away from the log. The sawmill key switch must be on before the in/out function can be performed. **NOTE:** The distance between the debarker blade and the side support with the cutting head all the way in is 6" (150mm) for the sawmill equipped with the standard head and 12" (300mm) for the sawmill equipped with the wide head.
- The Blade Motor ON/OFF toggle switch turns the blade motor on to start the debarker blade. The sawmill key switch must be on and the sawmill power feed drum switch must be activated in the forward direction before the blade motor can be turned on.
- The Blade ON indicator light comes on whenever the debarker blade motor is on.
- The blade motor circuit breaker can be reset by pushing the boot-covered tab on the back of the control box.

1.3 Operation

 **WARNING!** Make sure all guards and covers are in place and secured before operating the debarker option. Failure to do so may result in serious injury.

Keep all persons out of the path of moving equipment when operating the debarker.

1

Operation

Operation

1. Remove the debarker motor cover before operating.
2. Make sure the warning light is on when the debarker is turned on.



WARNING! Debarker is ON when warning light is on. DO NOT disconnect the warning light.

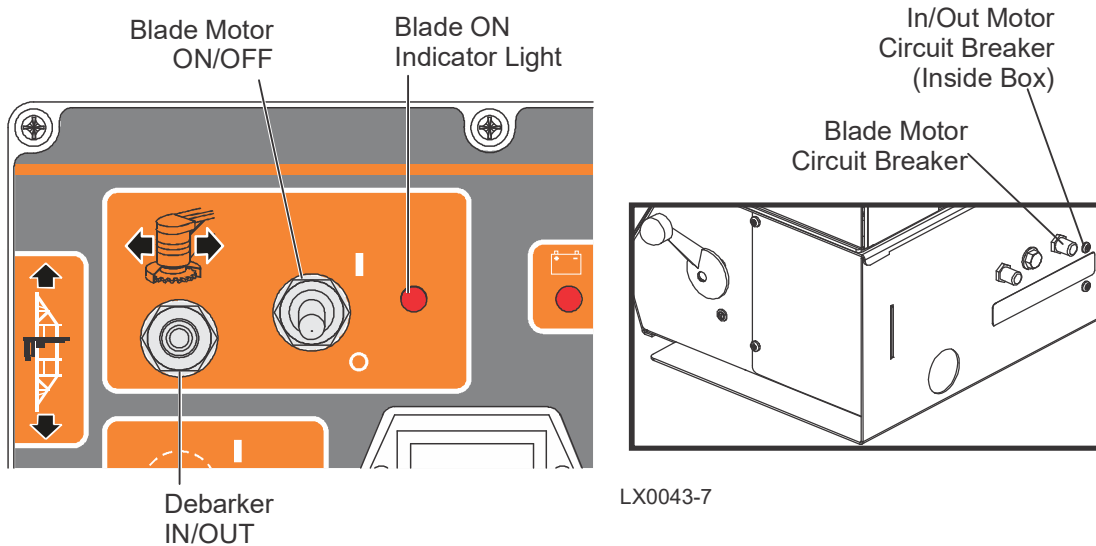



FIG. 1-1

3. Use the in/out switch  on the control box to pivot the debarker outboard.
4. Move the sawmill carriage forward and pivot the debarker in until the front fence engages with the end/side of the log.
5. Turn the debarker on/off  switch to ON (1).
6. Proceed with cutting.

The actuator will keep the debarker against the side of the log. Depending on log shape, you may have to pivot the debarker in and out for smooth cutting.

NOTE: The debarker can continuously remove up to approximately 1” of material from the log; no motor cool down time is required. Slower feed rates may be required for optimal debarker operation.

7. Once the carriage is past the end of the log, pivot the debarker away from the log.
8. Return the carriage.

NOTICE! Should the carriage be returned before the debarker has been pivoted out of the way of the log, the debarker is designed to pivot upwards. If this happens,

continue to **SLOWLY** return the carriage;
or stop, pivot the debarker out, and
then return the carriage.

DO NOT move the carriage forward while the debarker is contacting the log without the blade spinning.

9. When done sawing and ready to store or transport the sawmill, replace the debarker blade motor cover. Place the debarker in its travel position before towing the sawmill ([See Section 3.1](#)).

1.4 Maintenance



WARNING! Before performing any service to this equipment, turn the power toggle switch to the OFF position and disconnect the sawmill battery ground terminal. Failure to do so will result in serious injury or death.

1. Periodically check the flexible guard. Replace the guard as needed.
2. Periodically check the debarker blade. Align or replace as needed.



WARNING! Before replacing the debarker blade, move the sawmill blade guide arm in front of the sawmill blade to cover the blade teeth.

BLADE REPLACEMENT

1. Place one wrench on the blade holder bushing, above the blade.
2. Place the other wrench on the lower hex nut.
3. Remove the hex nut and washer.

4. Remove the blade and washer.
5. Reinstall the washer with the new blade.
6. Reinstall the hex nut and washer and **tighten to 35 foot-pounds (±5)**.



CAUTION! Tighten the blade hex nut manually. Using power-assisted tools may result in over-torquing and damage to the bolt.

1.5 Troubleshooting



WARNING! Turn the base unit's power to OFF, remove the key, and disconnect the battery ground terminal, if applicable.

PROBLEM	CAUSE	SOLUTION
Circuit breaker tripping	Wood or bark jammed in blade guard	Turn power toggle switch to OFF position. Remove wood or bark from blade guard
	Circuit breaker weak from repeated tripping.	Replace circuit breaker
Light comes on, but debarker motor and warning light (or horn prior to Rev. A.07) do not operate	Circuit breaker tripped	Reset circuit breaker.
Debarker shuts off, but the circuit breaker is not tripped.	Loose wiring connection	Check wiring connections inside control box.
Debarker will not shut off.	Solenoid is stuck closed.	Replace solenoid.

SECTION 1 ELECTRICAL

1.1 Components

Device tag	Function	Wood-Mizer Part Number	Wood-Mizer Description	Qty.	X-Ref
CB1	P/F Motor breaker	051981	Circuit Breaker, 40A	1	3.309
CB2	Up/Down Motor Breaker	051981	Circuit Breaker, 40A	1	2.204
CB3	Key Switch ST Terminal Breaker	E20430	Breaker, 15A Manual Reset	1	3.311
CB4	U/D Drum / DB In_Out Breaker	053464	Breaker, 10A Manual Reset	1	2.209
CB5	Key Switch IGN Terminal Breaker	E20430	Breaker, 15A Manual Reset	1	1.105
CB6	Key Switch ST Terminal Breaker	E20430	Breaker, 15A Manual Reset	1	1.106
CB8	Debarker Motor Breaker	024256	Circuit Breaker, 50A	1	3.315
CB21	U/D Drum / DB In_Out Breaker	053464	Breaker, 10A Manual Reset	1	3.318
D1	Limit Switch Diode "OR"	073668	Wire Assembly, LX150 Up/Down Limit Diode OR	2	1.117;2.209
D3	Diode Assy, Solenoid Coil	015426	Diode Assy, Solenoid Coil Chassis GND	1	3.314
D4	"	015426	Diode Assy, Solenoid Coil Chassis GND	1	1.114
D5	"	015426	Diode Assy, Solenoid Coil Chassis GND	1	1.116
F1	Battery Fuse	073683	Z-Case Fuse 60A	1	1.101
F2	Starter Fuse	073684	Z-Case Fuse 150A	1	1.102
G1	Battery	079462	Battery, 12V 8A24M AGM	1	1.101
HR1	Hour Meter	015401	Digital Meter, Hour Rect Mount w/Gasket	1	1.106
KS1	Key Switch	P04350	Switch, key	1	1.107
M1	Blade Guide Arm In/Out Motor	079214	Motor Assy, 1/30HP 12V Gear w/Flying Leads	1	1.109
M3	Up/Down Motor	006747	0.50 HP DC Motor	1	2.207
M4	Feed Motor	006747	0.50 HP DC Motor	1	3.307
M5	Debarker Motor	053683	0.75 HP DC Motor	1	3.315
M7	Debarker In/Out Motor	079214	Motor Assy, 1/30HP 12V Gear w/Flying Leads	1	3.318
5M	Debarker Solenoid	015470	Solenoid, 200A 12V SPST Cont. Duty	1	3.313
R1	Feed Rate Switch (Potentiometer)	024450	Pot Assy, Feed Rate Control Sawmill	1	3.302
S1	Forward/Reverse Drum Switch	E20439	Drum Switch, P/F	1	3.307
S2	Up/Down Drum Switch	E20440	Drum Switch, U/D	2	1.118;2.207
S5	Blade Guide Arm Switch	024200	Switch, DPDT Toggle 21A Rev Mom Spade	1	1.109
S6	Debarker In/Out Switch	024200	Switch, DPDT Toggle 21A Rev Mom Spade	1	3.319
SOL4	Solenoid, 200A DPST	015417	Solenoid, 200A 12V DPST Cont. Duty	1	1.114
SOL5	"	015417	Solenoid, 200A 12V DPST Cont. Duty	1	1.116
U1	SimpleSet H-Bridge Assembly	053373	Bridge, SS	1	1.114
U2	SimpleSet Controller	053774	Controller, SimpleSet	1	1.116
U3	SimpleSet Encoder Assembly	074021	Encoder Assy, SimpleSet	1	1.116
U8	USB/Assy Power Port	011274	USB/ASSY Port	1	3.310
U9	Forward Feed Control Module	073547	Module, Consolidated P/F	1	3.303

1.2 Wiring diagram

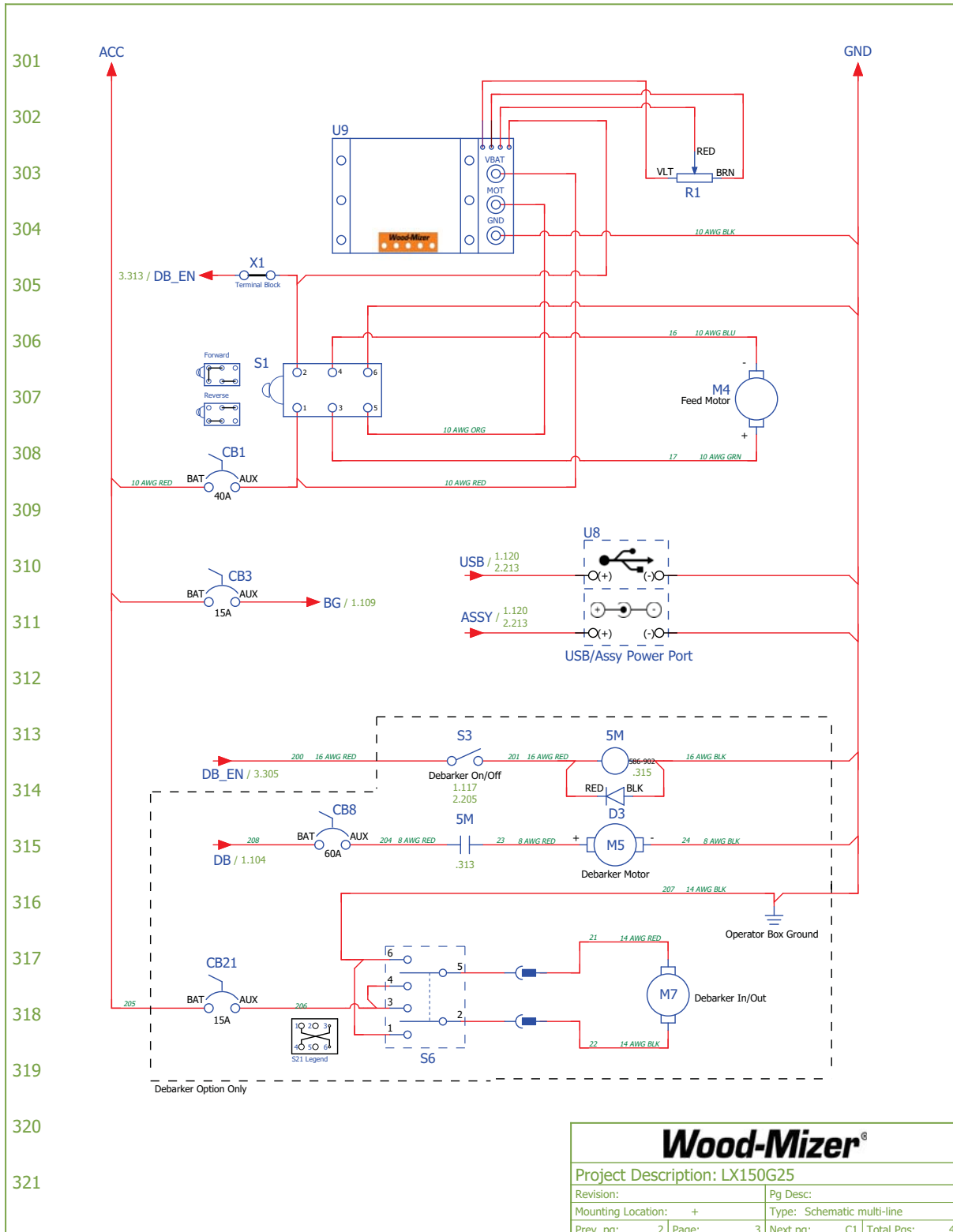

1 Electrical

Wiring diagram

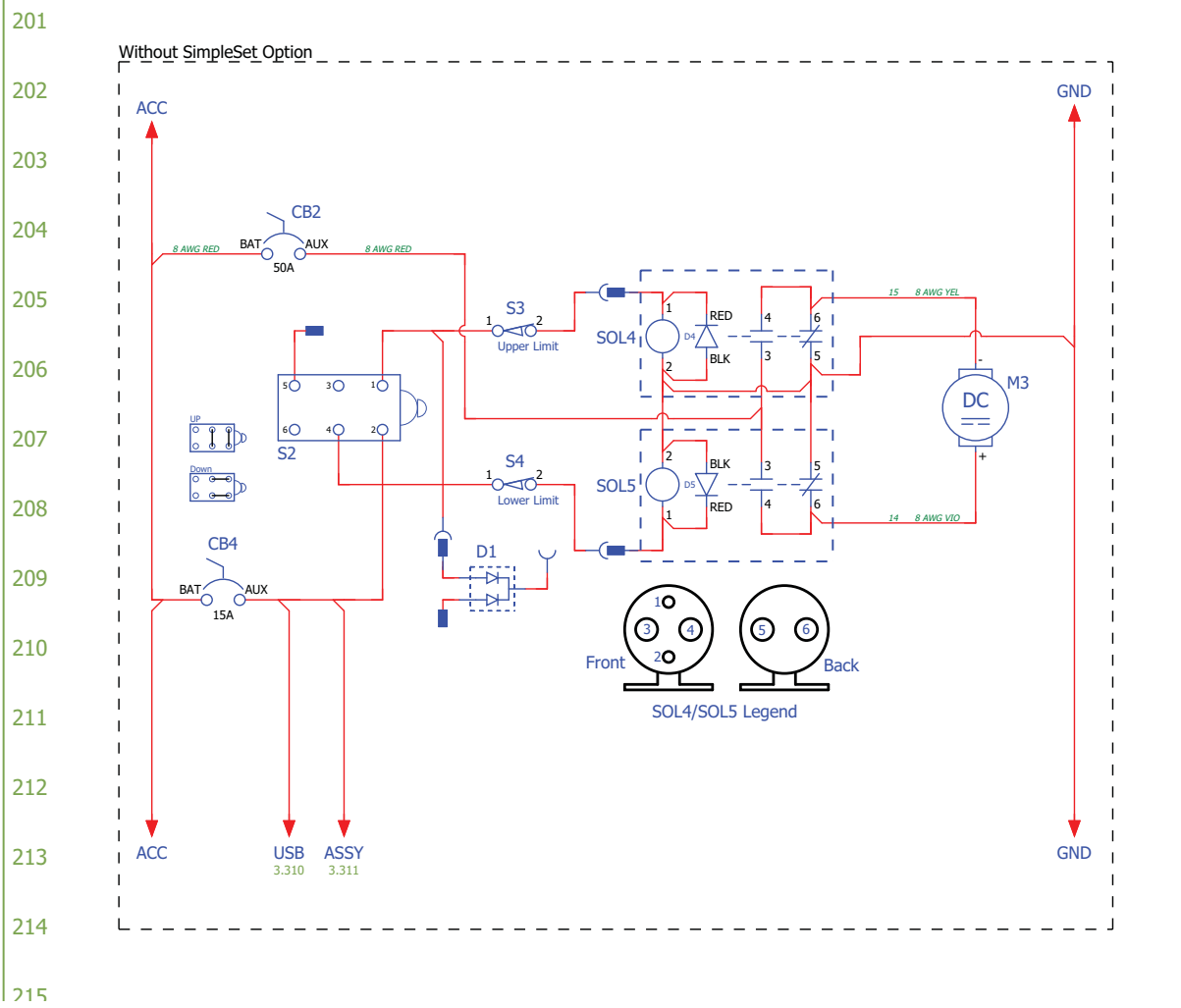

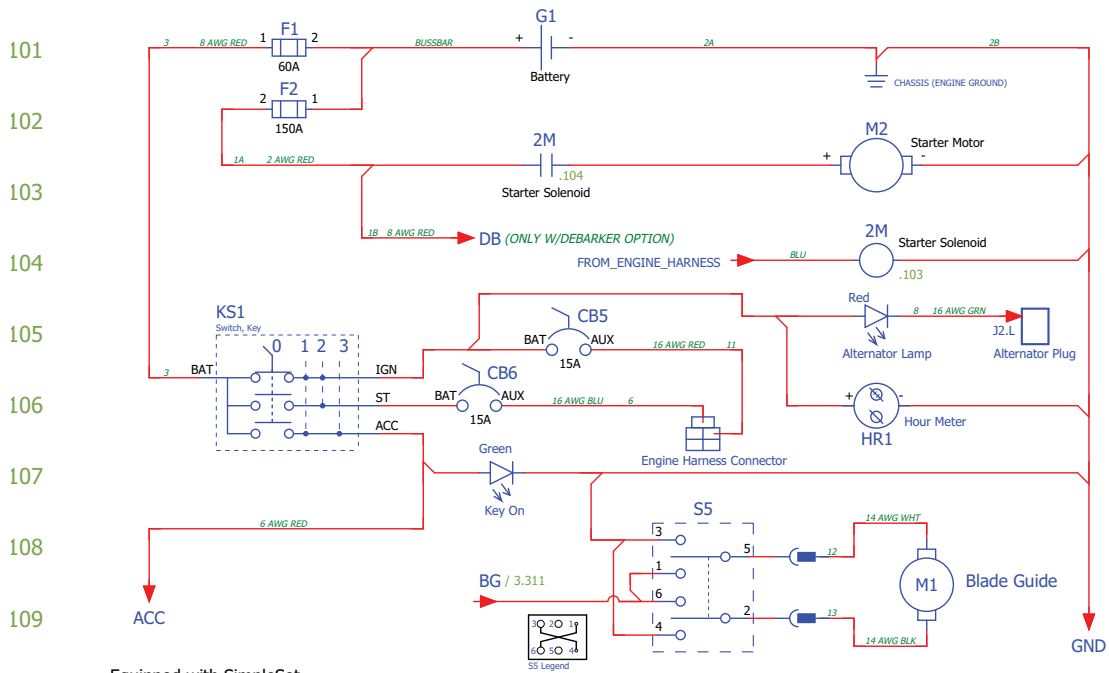

Equipped with SimpleSet

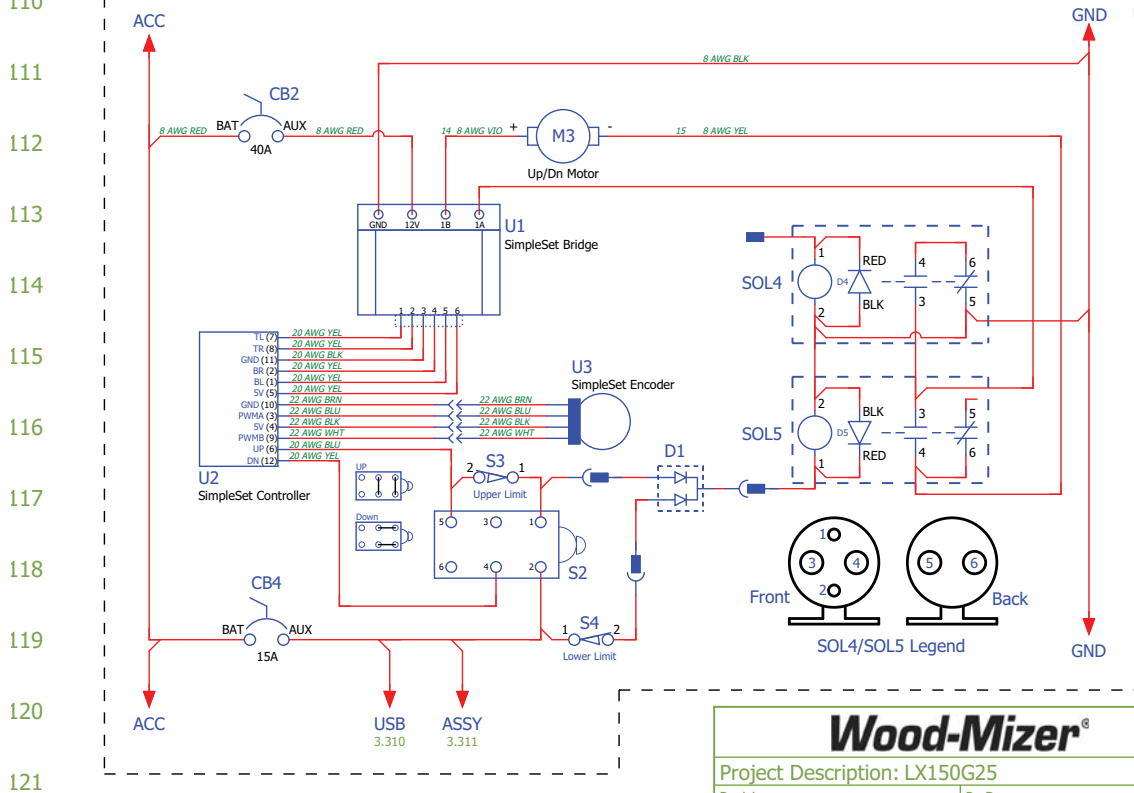

Wood-Mizer®			
Project Description: LX150G25			
Revision:	+	Pg Desc:	
Mounting Location:		Type:	Schematic multi-line
Prev. pg:	Page:	1	Next pg: 2 Total Pgs:

SECTION 2 PARTS

2.1 Debarker Assemblies

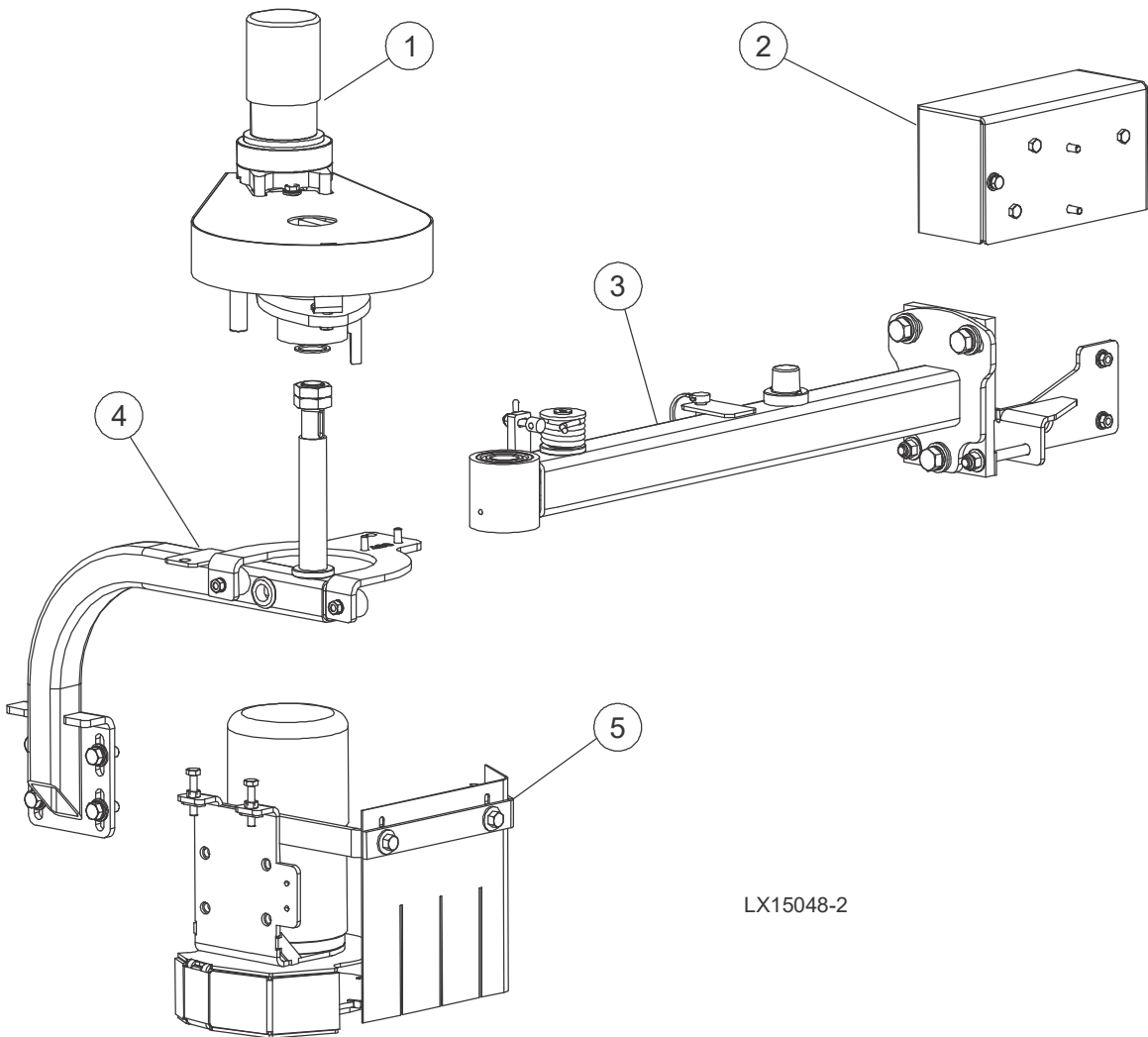

LX15048-2

REF	DESCRIPTION (◆ INDICATES PARTS AVAILABLE IN ASSEMBLIES ONLY)	PART #	QTY.
	ASSY, LX150 DEBARKER	113422	1
	ASSY, LX150 DEBARKER (FIELD INSTALLED)	113422-FI	1
1	Pivot head parts (See Section 2.2)	N/A	1
2	Assy, Debarker Solenoid/Breaker (See Section 2.3)	065749	1
3	Assy, LX150 Debarker Arm (See Section 2.4)	113427	1
4	Assy, Debarker Swing Arm and Stop Bracket(See Section 2.5)	113429	1
5	Assy, LX150 Debarker Cutter Head (See Section 2.6)	113427	1

2.2 Pivot Head

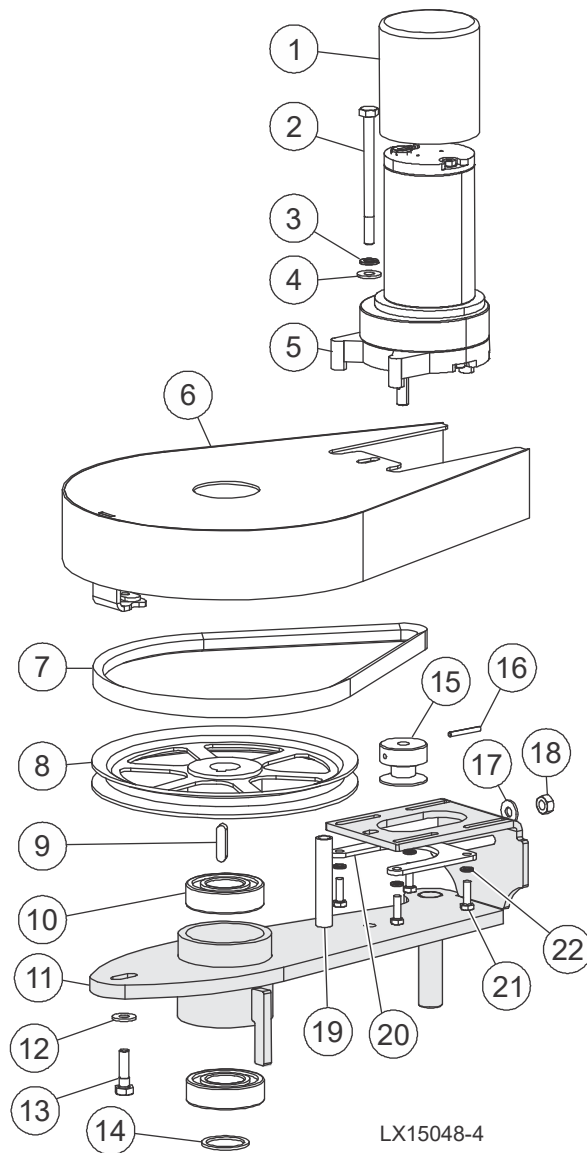

REF	DESCRIPTION (◆ INDICATES PARTS AVAILABLE IN ASSEMBLIES ONLY)	PART #	QTY.
1	CAP, RUBBER, 2.5 ID X 3	023720	1
2	SCREW, 1/4-20 X 3 1/2" HEX HEAD CAP GRADE 5	F05005-54	1
3	WASHER, 1/4" SPLIT LOCK	F05011-14	1
4	WASHER, 1/4"SAE FLAT	F05011-11	1
5	MOTOR, CURRENT APPLICATIONS 1/30HP 12VDC GEAR	079214	1
6	GUARD WELDMENT, LT35 DEBARKER	076161	1
7	BELT, 4L280	P04031	1
8	PULLEY, 7" X 20MM ID	076052	1
9	KEY, 6 X 6 X 25MM	076051	1

2 Parts

Pivot Head

REF	DESCRIPTION (◆ INDICATES PARTS AVAILABLE IN ASSEMBLIES ONLY)	PART #	QTY.	
10	BEARING, SKF 6205 2RS ROLLER	087353	2	
11	WELDMENT, LT35 DEBARKER PIVOT ARM	076047	1	
12	WASHER, 1/4"SAE FLAT	F05011-11	1	
13	BOLT, 1/4-20 X 1" HEX HEAD GRADE 5	F05005-101	1	
14	SHIM, 1" ID 1-1/4" OD	076037	1	
15	SHEAVE, GERMOTOR PINNED	016181	1	
16	PIN, 1/8" X 1" ROLL	F05012-34	1	
17	WASHER, 1/4"SAE FLAT	F05011-11	1	
18	NUT, 1/4-20 SWAGED	F05010-21	1	
19	SPACER, LT35 DEBARKER	076034	1	
20	TENSIONER WELDMENT, GERMOTOR	023637	1	
21	SCREW, 10-32X5/8 HH MACHINE	F05004-152	4	
22	WASHER, #10 SPLIT LOCK	F05011-20	4	

2.3 Debarker Solenoid Assembly

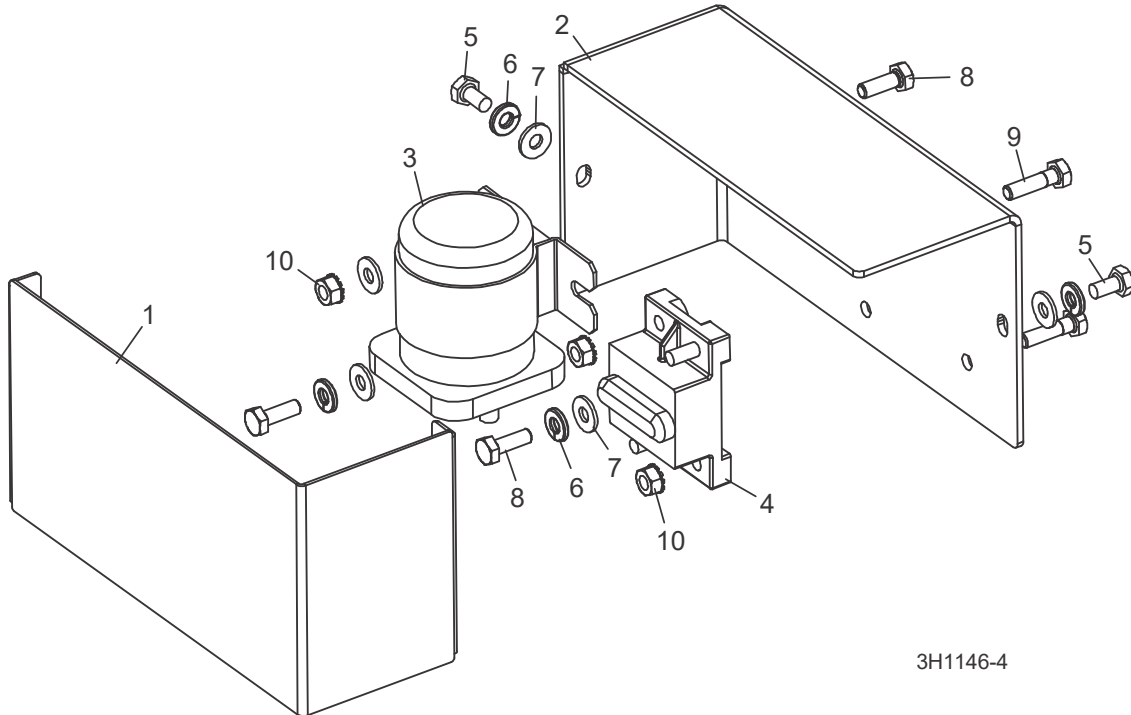

REF	DESCRIPTION (◆ Indicates Parts Available In Assemblies Only)	PART #	QTY.
	SOLENOID/BREAKER ASSEMBLY, DEBARKER	065749	1
1	Cover Weldment, Debarker Solenoid/Breaker	065759	1
2	Plate, Debarker Solenoid/Breaker Mount	065757	1
	Solenoid Kit, 200A 12V SPST Cont. Duty	016371	1
3	Solenoid, 200A 12V SPST Cont. Duty	015470	1
	Diode Assembly, Solenoid Coil Chassis GND	015426	1
	Instruction Sheet, Solenoid Replacement	016370-927	1
4	Breaker, 60A Hi-Amp Panel Mount	053440	1
5	Bolt, 1/4-20 x 1/2" Hex Head	F05005-15	2
6	Washer, 1/4" Split Lock	F05011-14	4
7	Washer, 1/4" SAE Flat	F05011-11	5
8	Bolt, 1/4-20 x 3/4" Full Thread Hex Head	F05005-1	3
9	Screw, 1/4-20 x 1" Hex Head Cap	F05005-38	2
10	Nut, 1/4-20 Keps	F05010-9	3

2 Parts Debarker Arm

2.4 Debarker Arm

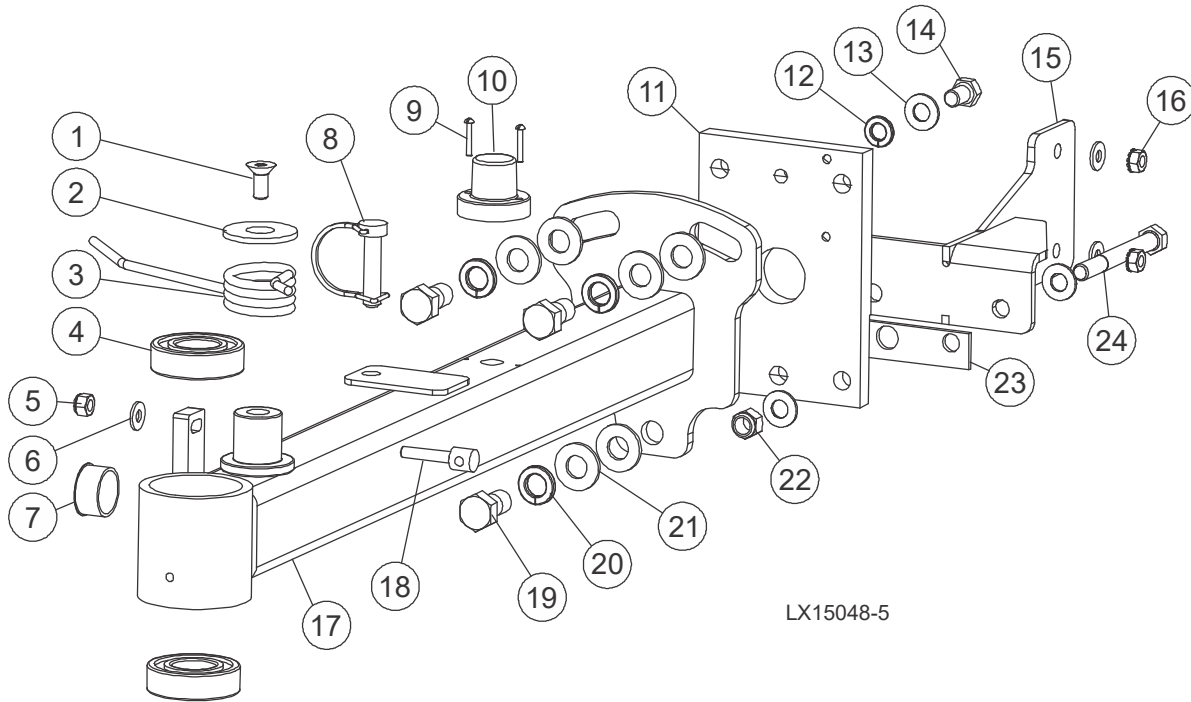

LX15048-5

REF	DESCRIPTION (♦ Indicates Parts Available in Assemblies Only)	PART #	QTY.
	ASSY, LX150 DEBARKER	113427	
1	Bolt, 5/16-18x3/4 FHS Zinc	F05006-95	1
2	Washer, LT35 Torsion Spring	076039	1
3	Spring, Debarker Tension	098605	1
4	Bearing, SKF 6205 2RS Roller	087353	2
5	Nut, 1/4-20 Nylock	F05010-69	1
6	Washer, 1/4 SAE Flat	F05011-11	3
7	Grommet, Heyco 13/16"	074557	1
8	Pin, 3/8x1 3/8 Rnd Wire Lock	046412	1
9	Bolt, 4-40x3/4 SI	F05004-13	2
10	Lamp Assy, 180 Degree Amber Strobe	073555	1
11	Plate, LX150 Debarker Mount	110739	1
12	Washer, 3/8 Split Lock	F05011-4	1
13	Washer, 3/8 Flat SAE	F05011-3	5
14	Bolt, 3/8-16x5/8 HH Gr5	F05007-148	1
15	Mount Weldment, Debarker Solenoid	110736	1
16	Nut, 1/4-20 Keps->	F05010-9	2
17	Weldment, LT35/LX150 Debarker	110702	1
18	Bushing, Debarker Spring Retaining	076139	1

REF	DESCRIPTION (♦ Indicates Parts Available in Assemblies Only)	PART #	QTY.	
19	Bolt, 1/2-13x1 HH	F05008-50	3	
20	Washer, 1/2 Split Lock	F05011-9	3	
21	Washer, 1/2 SAE Flat	F05011-2	6	
22	Nut, 3/8-16 Hex Nyloc	F05010-10	2	
23	Plate, Debarker Mount Spacer	065769	1	
24	Bolt, 3/8-16x3 1/2 HH Gr5	F05004-123	2	

2 Parts

Debarker Swing Arm and Stop Bracket

2.5 Debarker Swing Arm and Stop Bracket

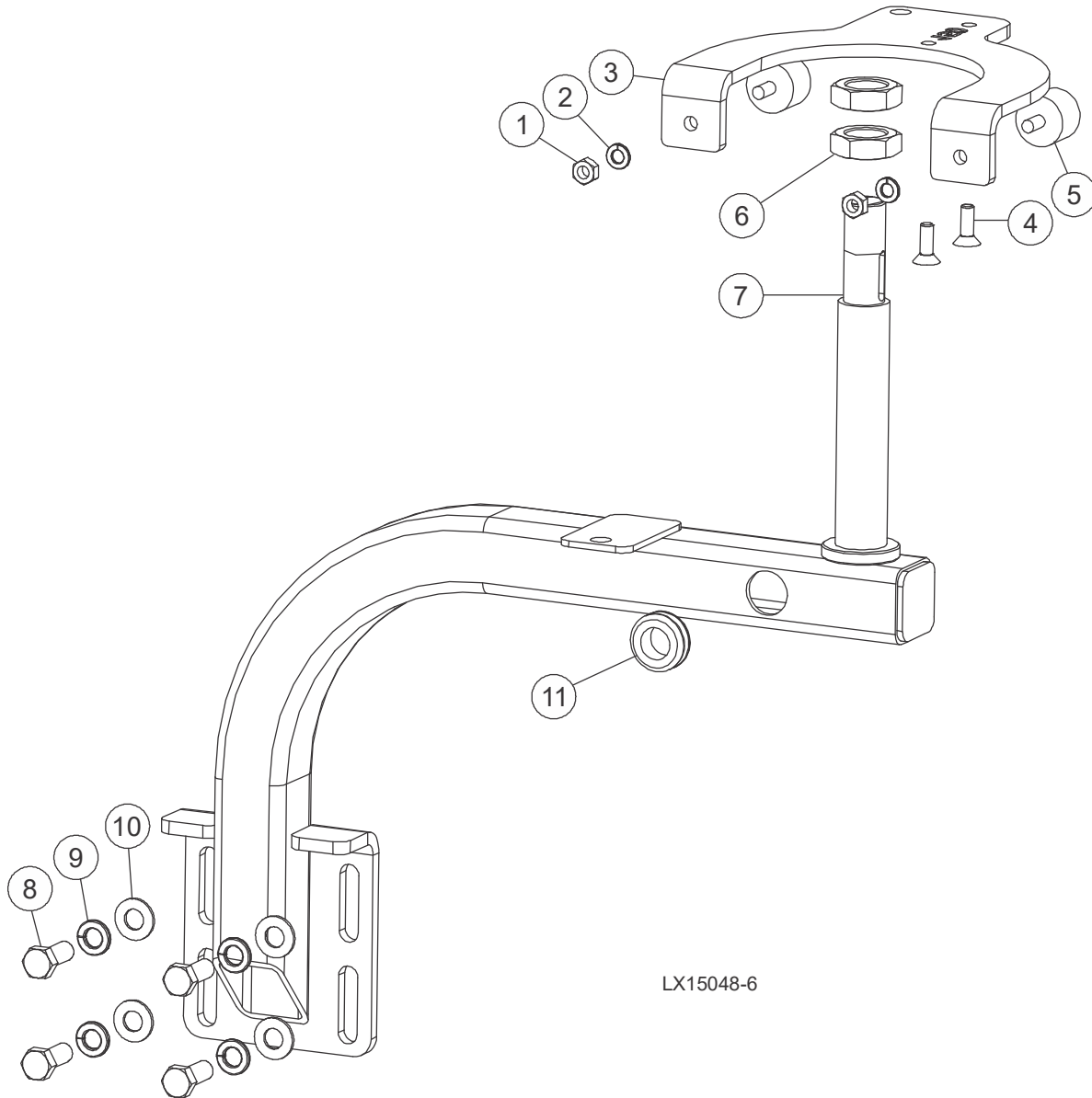

ASSY, DEBARKER SWING ARM		113429		
6	Nut, M20x1.5 Zinc Plated Thin	F81037-7	2	
7	Weldment, Debarker Swing Arm	076048	1	
8	Bolt, 3/8-16x1 HH Gr5	F05007-87	4	
9	Washer, 3/8 Split Lock	F05011-4	4	
10	Washer, 3/8 Flat SAE	F05011-3	4	
11	GROMMET, 5/8 ID 3/16 GW RUBBER	033475	1	

2.6 Cutter Head Assembly

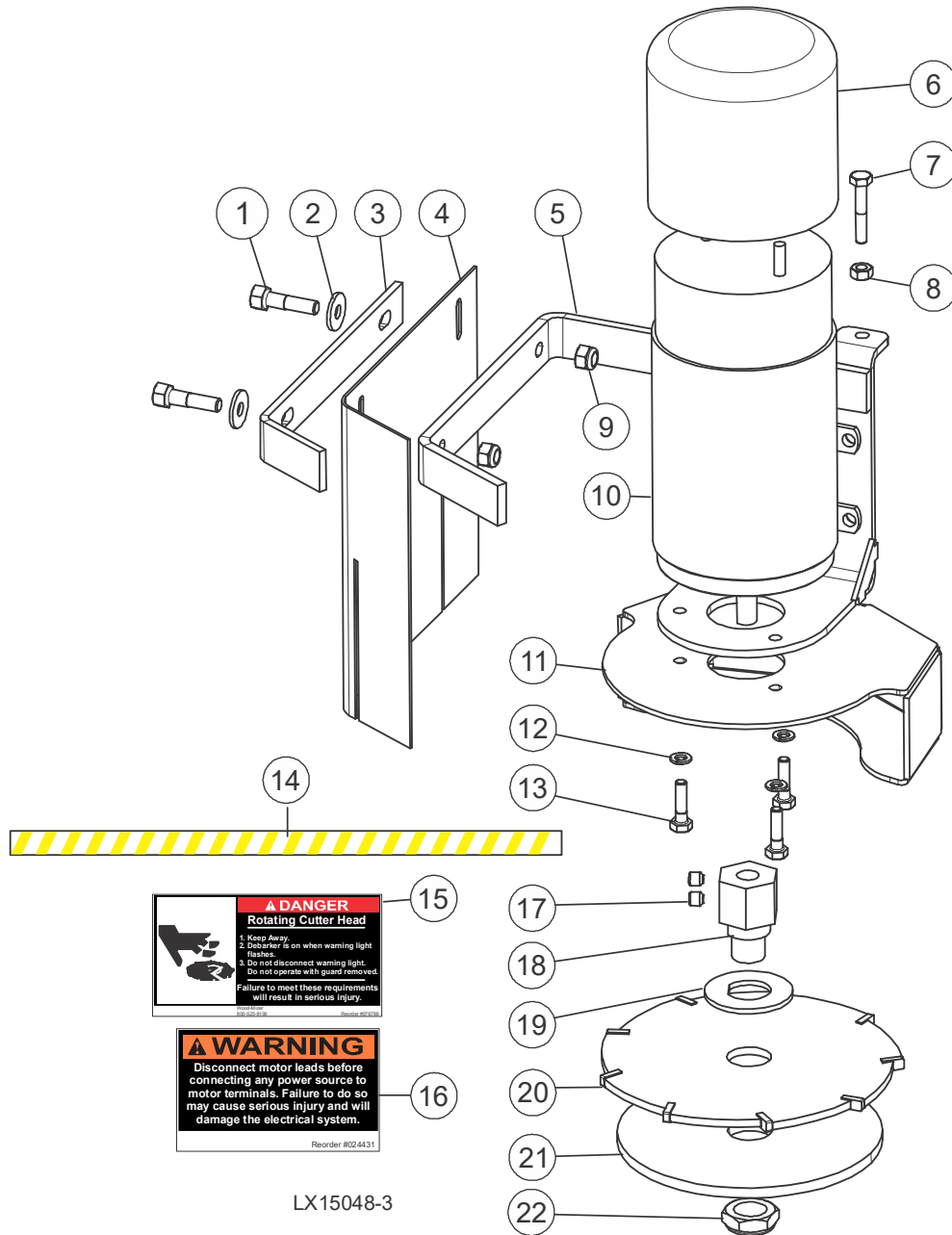

LX15048-3

REF	DESCRIPTION (◆ INDICATES PARTS AVAILABLE IN ASSEMBLIES ONLY)	PART #	QTY.	
	ASSY, LX150 DEBARKER CUTTER HEAD	113426		
1	Bolt, 5/16-18x1 1/4 HH	F05009-62	2	
2	Washer, 5/16 Standard Flat	F05011-16	2	
3	Retainer, LT35 Debarker Flex	076194	1	◆

2

Parts Cutter Head Assembly

REF	DESCRIPTION (◆ INDICATES PARTS AVAILABLE IN ASSEMBLIES ONLY)	PART #	QTY.	
4	Guard, Debarker Flex	076192	1	
5	Weldment, Debarker Cutter Head	076055	1	
6	Boot, LT35 Debarker Motor Rubber	065732	1	
7	Bolt, 1/4-20x1 1/2 HH FT	F05005-31	2	
8	Nut, 1/4-20 Free Zinc	F05010-63	2	
9	Nut, 5/16-18 Nylok Hex	F05010-58	2	
10	Motor, 3/4HP 12VDC Electric Std Mill	053683	1	
11	Guard, LX150 Debarker Blade	113425	1	
12	Washer, 1/4 Split Lock	F05011-14	3	
13	Bolt, 1/4-20x1 HH Gr5	F05005-101	3	
14	Decal, LT15 Blade Guide Bar	015849	1	
15	Decal, Debarker Light Warning	076799	1	
16	Decal, Disconnect Motor Leads Warning	024431	1	
17	Screw, 5/16-18x5/16 SH CP	F05006-6	2	
18	Bushing, Debarker Blade Holder	071000	1	
19	Washer, LT35 Debarker Blade	071001	1	
20	Blade, Debarker, 1/4 Kerf	021236	1	
	Blade, 7" Dia. Debarker w/1/2" Inserts (Optional -- Purchased Separately)	065852	1	
21	Guard, LT35 Debarker Depth	076195	1	
22	Nut, 3/4-10 Half Nyloc	F05010-122	1	