

# LT15 Power Feed Option

## Safety, Operation, Maintenance & Parts Manual

---

LT15PF	Rev. A.00-B.01
LT15E10LHPF	Rev. A.00-B.01
LT15E10SPF	Rev. A.00-C.01

---

**Safety is our #1 concern!**

*April 2010*

*Form #1567*

### USED WITH

LT15  
LT15W  
LT15S



**WARNING! Read and understand this manual before using this machine.**

## California

### Proposition 65 Warning



**WARNING:** Breathing gas/diesel engine exhaust exposes you to chemicals known to the State of California to cause cancer and birth defects or other reproductive harm.

Always start and operate the engine in a well-ventilated area.  
If in an enclosed area, vent the exhaust to the outside.  
Do not modify or tamper with the exhaust system.  
Do not idle the engine except as necessary.

For more information go to [www.P65warnings.ca.gov](http://www.P65warnings.ca.gov).



**WARNING:** Drilling, sawing, sanding or machining wood products can expose you to wood dust, a substance known to the State of California to cause cancer. Avoid inhaling wood dust or use a dust mask or other safeguards for personal protection.

For more information go to [www.P65Warnings.ca.gov/wood](http://www.P65Warnings.ca.gov/wood).

### Active Patents assigned to Wood-Mizer, LLC

Wood-Mizer, LLC has received patents that protect our inventions which are a result of a dedication to research, innovation, development, and design. Learn more at: [woodmizer.com/patents](http://woodmizer.com/patents)

### ©2024 Wood-Mizer LLC

Printed in the United States of America, all rights reserved. No part of this manual may be reproduced in any form by any photographic, electronic, mechanical or other means or used in any information storage and retrieval system without written permission from

**Wood-Mizer, LLC**  
**8180 West 10th Street**  
**Indianapolis, Indiana 46214**

**SECTION 1 POWER FEED OPTION INSTALLATION**

1.1 Power Feed Control (DC models)..... 1-1  
 1.2 Power Feed Control (AC models)..... 1-2  
 1.3 Electrical Components (LT15E10S)..... 1-2  
 1.4 Wiring (LT15E10S) ..... 1-3  
 1.5 Electrical Components (LT15E10H) ..... 1-5  
 1.6 Wiring (LT15E10H) ..... 1-5  
 1.7 Electrical Components (LT15E10L)..... 1-7  
 1.8 Feed Rope ..... 1-9  
 1.9 Feed Rope Adjustment Bracket ..... 1-9

**SECTION 2 OPERATION, MAINTENANCE & TROUBLESHOOTING**

2.1 Operation..... 2-10  
 2.2 Maintenance ..... 2-11  
 2.3 Troubleshooting ..... 2-11  
     *LT15PF Power Feed* ..... 2-11  
     *The saw head will not go forward or reverse:* ..... 2-11  
     *The saw head will not go in reverse:*..... 2-12  
     *The saw head will not go forward:*..... 2-12  
 2.4 LT15SPF/LT15LHPF Power Feed ..... 2-12  
     *The saw head will not go forward or reverse:* ..... 2-12

**SECTION 3 REPLACEMENT PARTS**

3.1 Power Feed Complete (LT15PF) ..... 3-1  
 3.2 Power Feed Complete (LT15E10SPF) ..... 3-2  
 3.3 Power Feed Complete(LT15E10LHPF) ..... 3-3  
 3.4 Power Feed Motor/Control (E10) ..... 3-4  
 3.5 Operator Control (All Except E10)..... 3-5  
     *LT15PF Rev. B.00+* ..... 3-5  
 3.6 Operator Control (E10 Only) ..... 3-6  
     *LT15PFE10SPF Rev. C.00+* ..... 3-6  
     *LT15LHPF Rev. B.00+* ..... 3-6  
 3.7 Operator Control (All LT15)..... 3-8  
     *LT15PF Prior to Rev. B.00* ..... 3-8  
     *LT15PFE10SPF Prior to Rev. C.00*..... 3-8  
     *LT15LHPF Prior to Rev. B.00* ..... 3-8  
 3.8 Rope Adjustment Bracket ..... 3-10

**SECTION 4 ELECTRICAL INFORMATION**

4.1 Wiring Diagram (Gas/Diesel LT15).....4-1  
     *LT15PF Rev. B.00+* ..... 4-1  
     *LT15PFE10SPF Rev. C.00+*..... 4-1  
     *LT15LHPF Rev. B.00+* ..... 4-1

4.2 Wiring Diagram (Gas/Diesel LT15).....4-2  
     *LT15PF Prior to Rev. B.00* ..... 4-2  
     *LT15PFE10SPF Prior to Rev. C.00*..... 4-2  
     *LT15LHPF Prior to Rev. B.00* ..... 4-2

4.3 Wiring Diagram (LT15E10S).....4-3  
     *LT15E10S Rev. A.03+*..... 4-3

4.4 Wiring Diagram (LT15E10S).....4-5  
     *LT15E10S Rev. A.00 - A.02*..... 4-5

4.5 Wiring Diagram (LT15E10L) .....4-7  
     *LT15E10L Rev. A.03+* ..... 4-7

4.6 Wiring Diagram (LT15E10L) .....4-9  
     *LT15E10L Rev. A.00 - A.02* ..... 4-9

4.7 Wiring Diagram (LT15E10H).....4-11  
     *LT15E10H Rev. A.03+*..... 4-11

4.8 Wiring Diagram (LT15E10H).....4-14  
     *LT15E10H Rev. A.00 - A.02*..... 4-14

4.9 Electrical Components (LT15PF).....4-17  
     *LT15PF Rev. B.00+* ..... 4-17  
     *LT15PFE10SPF Rev. C.00+*..... 4-17  
     *LT15LHPF Rev. B.00+* ..... 4-17

4.10 Electrical Components (LT15PF).....4-17  
     *LT15PF Prior to Rev. B.00* ..... 4-17  
     *LT15PFE10SPF Prior to Rev. C.00*..... 4-17  
     *LT15LHPF Prior to Rev. B.00*..... 4-17

4.11 Electrical Components (LT15E10SPF).....4-17

4.12 Electrical Components (LT15E10LHPF).....4-18

4.13 Motor Driver Module DIP Switch Settings.....4-18

## SECTION 1 POWER FEED OPTION INSTALLATION

The Power Feed option may be assembled to any LT15 model sawmill equipped with a battery-start engine and bolt-on manual feed crank (Rev. E4.00 and later) or AC motor with updated control box (Rev. E6.06 and later). The option feeds the blade through the material without manually cranking. The power feed option feed rate is up to 95 feet per minute (forward & reverse).

### 1.1 Power Feed Control (DC models)

1. Raise the saw head so the manual feed crank handle is easily accessible.
2. Unbolt the two 3/8" hex head bolts and flat washers securing the manual feed push bar and crank handle to the mast upright and remove from the sawmill.
3. Remove the hold-down strap from the battery box and lift the battery box cover from the box. See Fig. 1-1.
4. Remove the four 3/8" mounting bolts and flat washers from the power feed control (the hex nuts on the top two bolts are provided for shipping only and are not needed for installation).
5. Bolt the previously removed manual feed push bar to the lower two mounting holes in the power feed mounting bracket.
6. Secure with the provided 3/8" hex head bolts and flat washers.
7. Install the power feed control assembly to the mast upright with two 3/8" hex head bolts and flat washers in the upper two mounting holes. See Fig. 1-2.
8. Route the power harness to the battery box and connect the black wire to the negative battery terminal and the red wire to the positive battery terminal.
9. Remove the right-side battery box mount bolt and washers and use to secure the harness clamp to the battery box mount.
10. Replace the battery box lid.

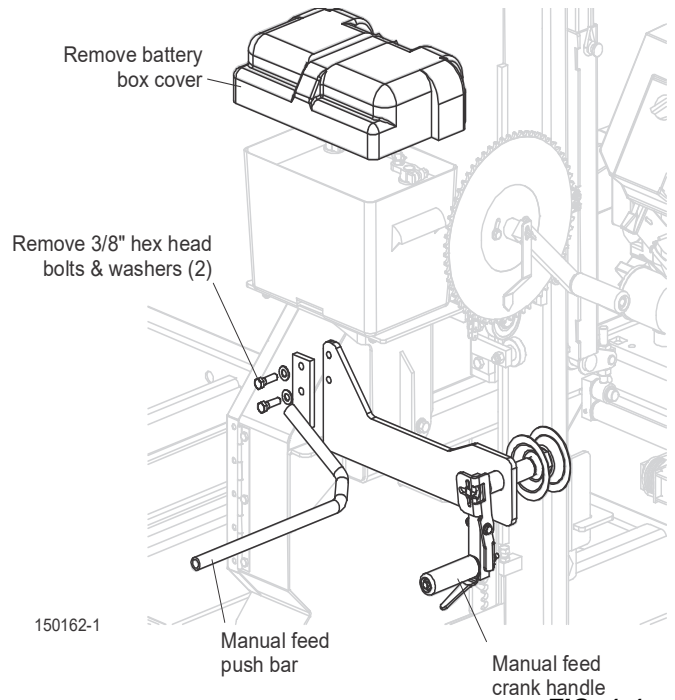

**FIG. 1-1**

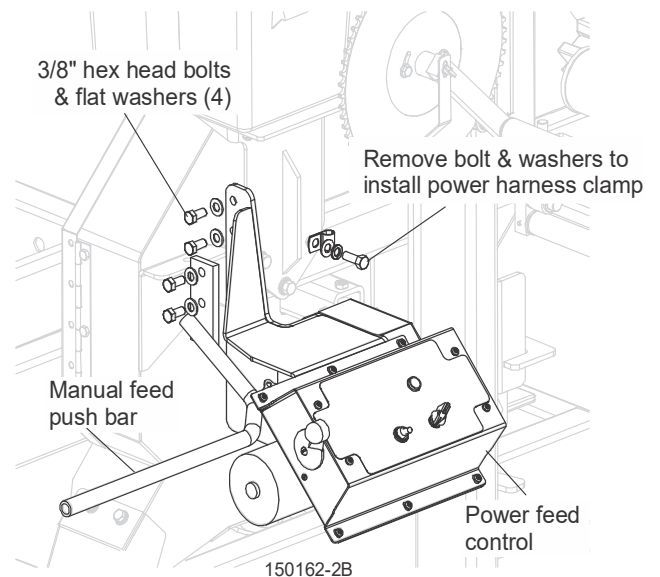

**FIG. 1-2**

## 1.2 Power Feed Control (AC models)

### ELECTRICAL BOX

1. Raise the saw head so the manual feed crank handle is easily accessible.
2. Disconnect and lockout the electrical power supply to the sawmill.

**⚠ DANGER!** HAZARDOUS VOLTAGE can cause shock, burns, or death. SHUT OFF & LOCK OUT POWER before performing service in any area of this machine. DO NOT restore power until all service is complete and electrical control is securely closed.

3. Open the electrical control box door.
4. Locate the three knockout holes in the **bottom-right** of the control box.
5. Use a hammer and punch to remove the **rear** knockout. See Fig. 1-3.

### CONTROL ASSEMBLY

6. Unbolt the two 3/8" hex head bolts and flat washers securing the manual feed push bar and crank handle to the mast upright and remove from the sawmill. See Fig. 1-3.
7. Remove the four 3/8" mounting bolts and flat washers from the power feed control (the hex nuts on the top two bolts are provided for shipping only and are not needed for installation).
8. Remove the locking nut from the elbow connector at the end of the feed control harness.
9. Bolt the previously removed manual feed push bar to the lower two mounting holes in the power feed mounting bracket.
10. Secure with the provided 3/8" hex head bolts and flat washers.

11. Install the power feed control assembly to the mast upright with two 3/8" hex head bolts and flat washers in the upper two mounting holes. See Fig. 1-4.
12. Install the power feed control harness to the hole in the bottom of the electrical control box.
13. Secure with the previously removed locking nut.
14. Remove the right-side control box mount bolt and washers and use to secure the harness clamp to the control box mount.

## 1.3 Electrical Components (LT15E10S)

1. Locate the end clamp to the right of fuses F5 & F6.
2. Loosen and slide to the right.

### FUSE BLOCK

3. Install the fuse block to the DIN rail to the right of fuses F5 & F6. See Fig. 1-5.
4. Clip the top of the mounting edge of the fuse block onto the top of the DIN rail.
5. Push down to snap the bottom of the fuse block onto the DIN rail.
6. Slide the end clamp against the fuse block and tighten.

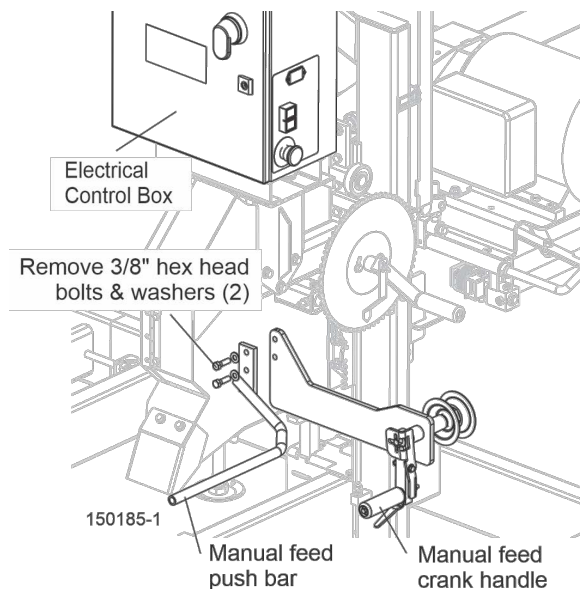

**FIG. 1-3**

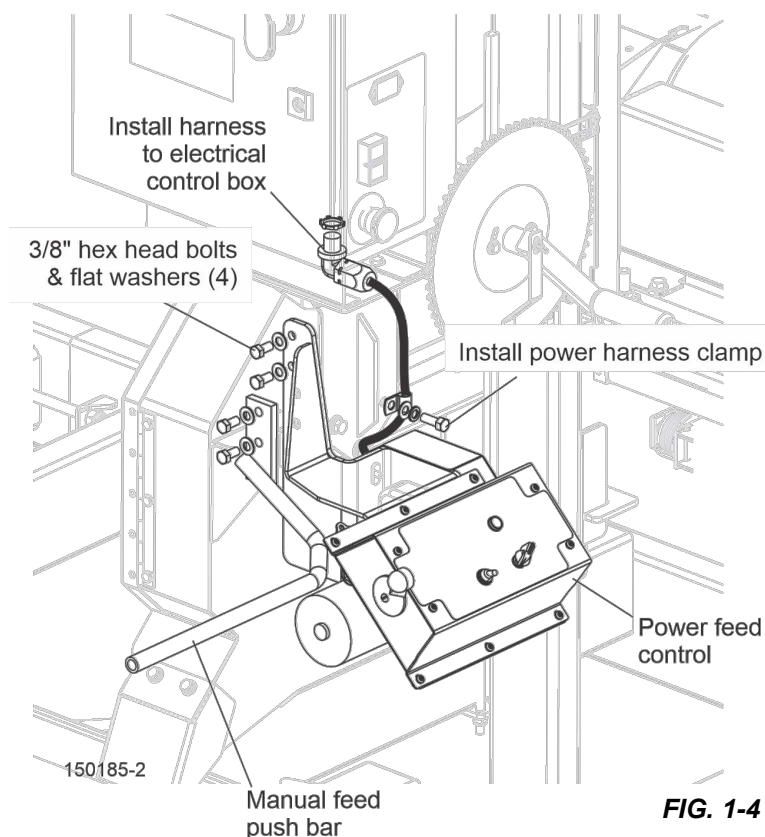

**FIG. 1-4**

## TERMINAL BLOCK

7. Locate the end clamp to the left of terminal block TB2 beside the power supply (PWR1). See Fig. 1-5.
8. Loosen the clamp and slide the clamp and the terminal block to the left.
9. Install the provided relay R1 to the DIN rail to the left of the power supply.
10. Slide terminal block TB2 against the relay and install the provided terminal block TS2 to the left of TB2.
11. Slide the end clamp against the terminal block and tighten.

## POWER SUPPLY

12. Remove the four 4mm bolts, lock washers and nuts from the left side of the electrical control box.
13. Discard the nuts only.
14. Place the provided power supply in position over the mounting holes with the terminal points and wires facing down.
15. Secure with the previously removed 4mm bolts and lock washers. See Fig. 1-5.

## DIODE RECTIFIER

16. Install the diode rectifier BR1 to the bottom of the box.

### 1.4 Wiring (LT15E10S)

1. Remove the cable duct covers to access the control wiring. See Fig. 1-6.
2. Insert a screwdriver into the slots of TS2.2 and disconnect wires #55 and #80.
3. Connect wire #55 to R1 relay terminal #13.
4. Connect wire #80 to R1 relay terminal #14.
5. Locate both of the three-levered terminal blocks in the very top cable duct.
6. Open the available lever on the block with wires labeled 2L1 and install the black wire from fuse block F7.
7. Close the lever to secure the wire.
8. Open the available lever on the block with wires labeled 2L2 and install the black wire from fuse block F8.
9. Close the lever to secure the wire.
10. Connect the green/yellow wire from the power supply GND terminal to the grounding stud in the bottom left-hand corner of the enclosure.
11. Remove the lock nut from the grounding stud, install the wire ring terminal over the stud (keep existing wire in place on stud).

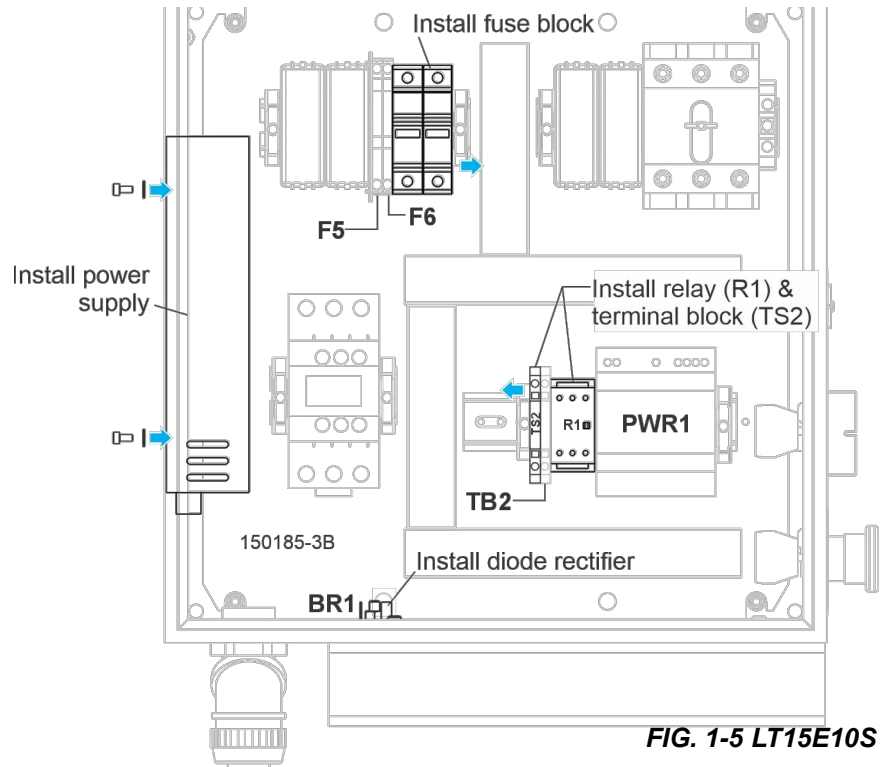

FIG. 1-5 LT15E10S

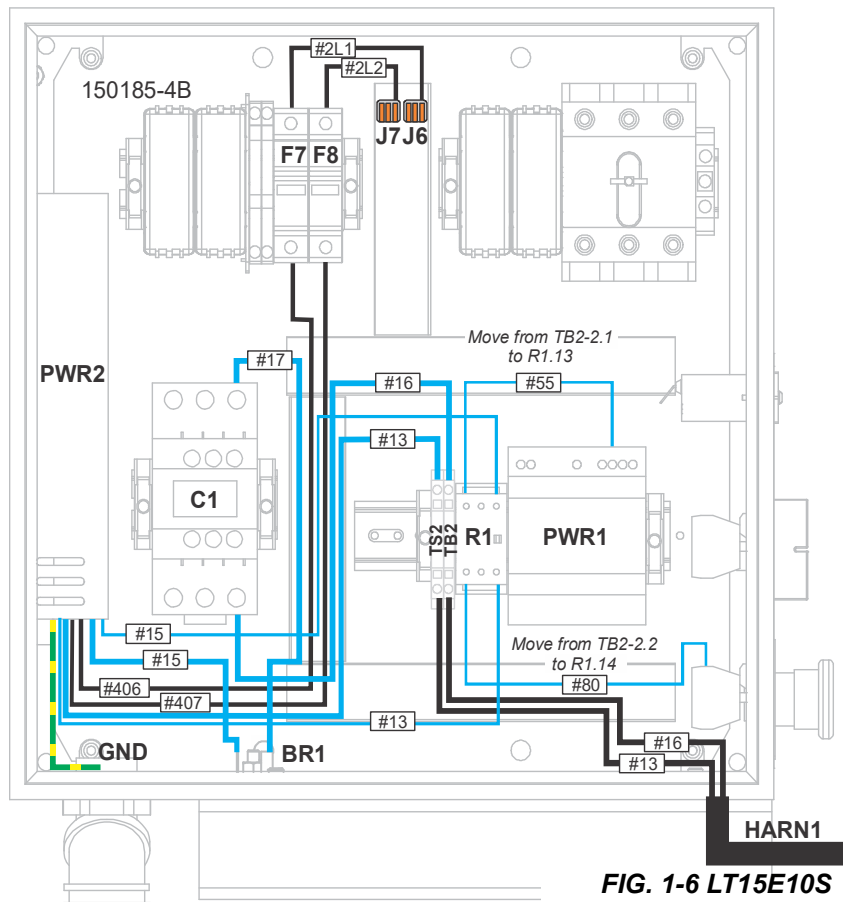

FIG. 1-6 LT15E10S

12. Reinstall and tighten the grounding stud lock nut.
13. Route wires #406 and #407 from the power supply L & N terminals through the cable ducts to the new fuse blocks F7 & F8.
14. Connect wire #406 to the bottom terminal of fuse block F7.
15. Connect wire #407 to the bottom terminal of fuse block F8.
16. Route the thick blue wire #13 from the power supply -VL terminal through the cable ducts to the top of the new terminal block TS2.2 and connect.
17. Route the thin blue wire #13 from the power supply -VR terminal to the bottom of the new relay R1 and connect to terminal A2.
18. Route the thick blue wire #17 from the diode rectifier BR1 through the cable ducts to the top of contactor C1 and connect to 5/L3.
19. Route the thin blue wire #15 from the power supply +VR terminal to the top of the new relay R1 and connect to terminal A1.
20. Locate the provided loose blue wire #16 and connect one end to the top terminal of terminal block TB2.1.
21. Route the wire through the cable ducts to the bottom of contactor C1 and connect to terminal 6/T3.
22. Route both black wires from the power feed control harness HARN1 through the cable ducts to the bottom of the terminal blocks next the newly-installed relay.
23. Connect wire #13 to the new terminal block TS2.1.
24. Connect wire #16 to the bottom of the existing terminal block TB2.2. See Fig. 1-6.
25. Ensure all connections are properly secure and replace the cable duct covers.
26. Close the control box door.

## TEST

27. Restore power to the machine and turn the disconnect handle to ON.
28. Turn the emergency stop clockwise to release.
29. Push the blade motor ON button.
30. The button should light green.  
**NOTE:** The power feed will not operate unless the blade motor is ON.
31. On the power feed operator control, turn the toggle switch to the ON position.  
The green light on the power feed control should light.
32. Turn the power feed rate switch all the way to the left.
33. Push the power feed drum switch handle forward.
34. Slowly turn the feed rate switch to the right.
35. The saw head should move forward.
36. Increase the forward speed by turning the feed rate switch further to the right.
37. Push the power feed drum switch handle back to return the saw head to the front of the sawmill.

**NOTE:** The control bypasses the feed rate switch in the reverse direction, returning the saw head at the fastest speed possible.

38. Return the power feed drum switch handle to the neutral position to stop the saw head moving.
39. Push the emergency stop button on the electrical control box.
40. All functions should now be off and disabled.
41. Installation and testing of the power feed option is now complete.



## 1.5 Electrical Components (LT15E10H)

### FUSE BLOCK

1. Locate and remove the end clamps to the right of fuses F7 & F8.
2. Install the fuse block to the DIN rail to the right of fuses F7 & F8.
3. Clip the top of the mounting edge of the fuse block onto the top of the DIN rail.
4. Push down to snap the bottom of the fuse block onto the DIN rail.
5. Slide the end clamp and tighten.

### TERMINAL BLOCK

6. Locate the end clamp to the left of terminal block TB2 beside the power supply (PWR1) and slide the clamp to the left.
7. Insert a screwdriver into the slots of TB2 and disconnect all wires and remove the terminal block from the DIN rail.
8. Install the provided relay to the DIN rail to the left of the power supply.
9. Install the provided contactor against the relay.
10. Slide the end clamp against the contactor and tighten.
11. Remove the four 4mm bolts, lock washers and nuts from the left side of the electrical control box.
12. Discard the nuts only.
13. Place the provided power supply in position over the mounting holes with the terminal points and wires facing down.
14. Secure with the previously removed 4mm bolts and lock washers. See Fig. 1-7.

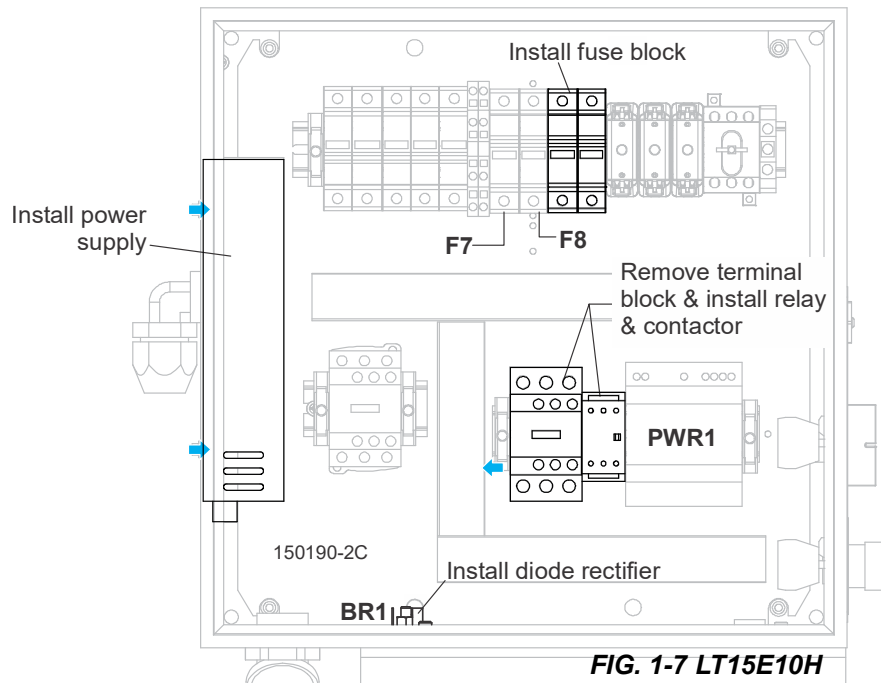

FIG. 1-7 LT15E10H

### DIODE

15. Install the diode rectifier BR1 to the bottom of the box.

## 1.6 Wiring (LT15E10H)

1. Remove the cable duct covers to access the control wiring. See Fig. 1-8.
2. Connect wire #4L1 from fuse block F9 to terminal block TS1.2 terminal #2.
3. Connect wire #4L2 from fuse block F10 to terminal block TS1.3 terminal #2.
4. Connect the green/yellow wire from the power supply GND terminal to the grounding stud in the bottom left-hand corner of the enclosure.
5. Remove the lock nut from the grounding stud, install the wire ring terminal over the stud (keep existing wire in place on stud).
6. Reinstall and tighten the grounding stud lock nut.
7. Route wires #408 and #409 from the power supply L & N terminals through the cable ducts to the new fuse blocks F9 & F10.
8. Connect wire #408 to the bottom terminal of fuse block F9.
9. Connect wire #409 to the bottom terminal of fuse block F10.

# 1 Power Feed Option Installation

Wiring (LT15E10H)

10. Route the thick blue wire #13 from the power supply -VL terminal through the cable ducts to the top of the new contactor C2 and connect to terminal 3/L2.
11. Route the thin blue wire #13 from the power supply -VR terminal to the bottom of the new relay R1 and connect to terminal A2.
12. Route the thick blue wire #17 from the diode rectifier BR1 through the cable ducts to the top of new contactor C2 and connect to terminal 1/L1.
13. Route the thin blue wire #15 from the power supply +VR terminal to the top of the new relay R1 and connect to terminal A1.
14. Route blue wire #53 from new contactor C2.A2 to the top of the power supply PWR1 and connect to the right "-" terminal.
15. Route blue wire #99 from new contactor C2.A1 to the bottom of existing contactor C1 and connect to terminal #14.
16. Route blue wire #55 previously removed from the terminal block to the top of the new relay R1 and connect to terminal #13.
17. Route blue wire #80 previously removed from the terminal block to the bottom of the new relay R1 and connect to terminal #14.

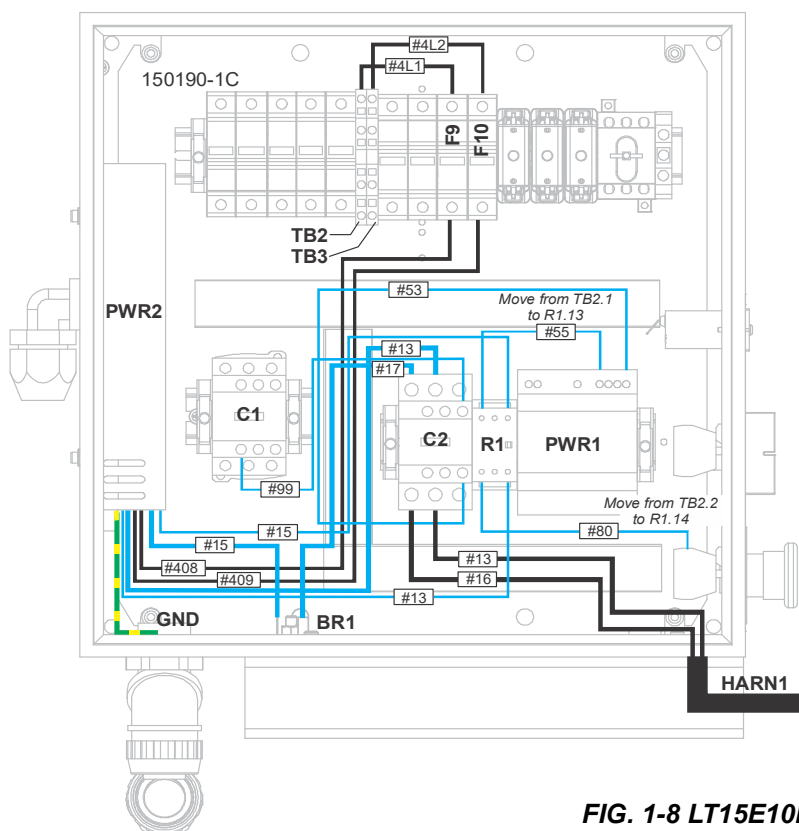

FIG. 1-8 LT15E10H

18. Route both black wires from the power feed control harness HARN1 through the cable ducts to the bottom of the newly-installed contactor.
19. Connect wire #13 to contactor terminal #4/T2.
20. Connect wire #16 to contactor terminal #2/T1. See Fig. 1-8.
21. Ensure all connections are properly secure and replace the cable duct covers.
22. Close the control box door.
23. Restore power to the machine and turn the disconnect handle to ON.
24. Turn the emergency stop clockwise to release.
25. Push the blade motor ON button. The button should light green.

**NOTE:** The power feed will not operate unless the blade motor is ON.

26. On the power feed operator control, turn the toggle switch to the ON position.
27. The green light on the power feed control should light.
28. Turn the power feed rate switch all the way to the left.
29. Push the power feed drum switch handle forward.
30. Slowly turn the feed rate switch to the right.
31. The saw head should move forward. Increase the forward speed by turning the feed rate switch further to the right.
32. Push the power feed drum switch handle back to return the saw head to the front of the sawmill.

**NOTE:** The control bypasses the feed rate switch in the reverse direction, returning the saw head at the fastest speed possible.

33. Return the power feed drum switch handle to the neutral position to stop the saw head moving.
34. Push the emergency stop button on the electrical control box.

35. All functions should now be off and disabled.

Installation and testing of the power feed option is now complete.

## 1.7 Electrical Components (LT15E10L)

1. Locate and remove the end clamps to the right of fuses F7 & F8.
2. Install the fuse block to the DIN rail to the right of fuses F7 & F8.
3. Clip the top of the mounting edge of the fuse block onto the top of the DIN rail.
4. Push down to snap the bottom of the fuse block onto the DIN rail.
5. Slide the end clamp and tighten.
6. Locate the end clamp to the left of terminal block TB2 beside the power supply (PWR1) and slide the clamp to the left.
7. Insert a screwdriver into the slots of TB2 and disconnect all wires and remove the terminal block from the DIN rail.
8. Install the provided relay to the DIN rail to the left of the power supply.
9. Install the provided contactor against the relay.
10. Slide the end clamp against the contactor and tighten.

11. Remove the four 4mm bolts, lock washers and nuts from the left side of the electrical control box.

12. Discard the nuts.

13. Place the provided power supply in position over the mounting holes with the terminal points and wires facing down.

14. Secure with the previously removed 4mm bolts and lock washers. See Fig. 1-9.

15. Install the diode rectifier BR1 to the bottom of the box.

16. Remove the cable duct covers to access the control wiring. See Fig. 1-10.

17. Locate the two levered terminal blocks at the top of the electrical control box.

18. Open the available lever on the block with wires labeled 4L1 and install the black wire from fuse block F9.

19. Close the lever to secure the wire.

20. Open the available lever on the block with wires labeled 4L2 and install the black wire from fuse block F10.

21. Close the lever to secure the wire.

22. Connect the green/yellow wire from the power supply GND terminal to the grounding stud in the bottom left-hand corner of the enclosure.

23. Remove the lock nut from the grounding stud, install the wire ring terminal over the stud (keep existing wire in place on stud).

24. Reinstall and tighten the grounding stud lock nut.

25. Route wires #408 and #409 from the power supply L & N terminals through the cable ducts to the new fuse blocks F9 & F10.

26. Connect wire #408 to the bottom terminal of fuse block F9.

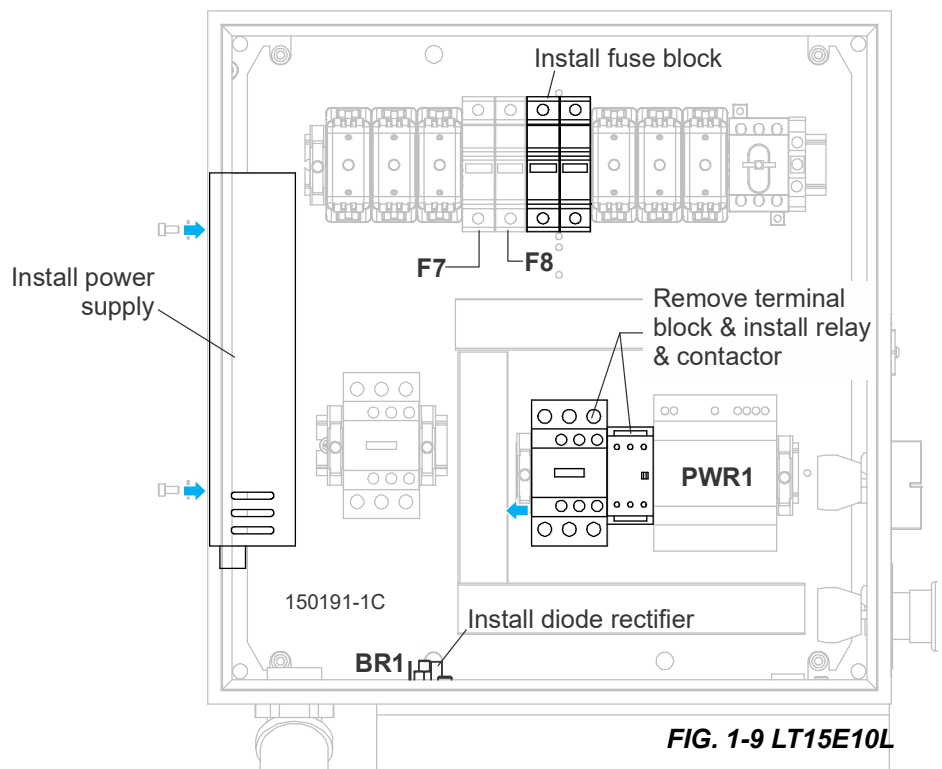

**FIG. 1-9 LT15E10L**



52. Push the power feed drum switch handle back to return the saw head to the front of the sawmill.

**NOTE:** The control bypasses the feed rate switch in the reverse direction, returning the saw head at the fastest speed possible.

53. Return the power feed drum switch handle to the neutral position to stop the saw head moving.

54. Push the emergency stop button on the electrical control box.

55. All functions should now be off and disabled.

Installation and testing of the power feed option is now complete.

## 1.8 Feed Rope

1. Remove the feed rope pulley cover from the power feed control unit. See Fig. 1-11.
2. Install the feed rope to the mounting brackets and lower feed pulley as instructed in your sawmill operator's manual.
3. Route the feed rope up from the lower feed pulley and wrap once counter clockwise around the power feed pulley.
4. Continue feed rope installation as outlined in your sawmill operator's manual.
5. Replace the feed rope pulley cover.

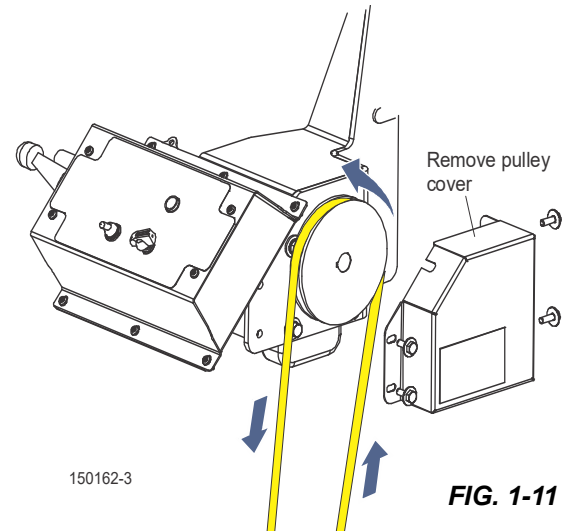

FIG. 1-11

## 1.9 Feed Rope Adjustment Bracket

6. Install the provided feed rope adjustment bracket.

This adjustment allows you to tighten the feed rope and prevent slippage.

1. Unhook both ends of the feed rope from the feed rope brackets.
2. Remove one of the existing feed rope brackets from the sawmill bed.
3. Install one end of the feed rope to the eye bolt.
4. Install the provided feed rope adjustment bracket to the sawmill bed as shown below.
5. Install the eye bolt to the feed rope adjustment bracket and secure with the provided fasteners. See Fig. 1-12.
6. Reinstall the other end of the feed rope to the existing feed rope bracket.
7. Make sure the feed rope is very tight.
8. Use the eye bolt hex nuts to tighten the feed rope as necessary so there no rope slipping during sawmill operation.

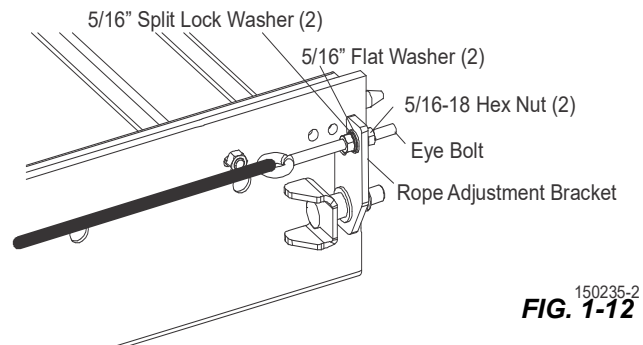

FIG. 1-12

## SECTION 2 OPERATION, MAINTENANCE & TROUBLESHOOTING

### 2.1 Operation

**! DANGER!** Make sure all guards and covers are in place and secured before operating the sawmill. Failure to do so may result in serious injury.

1. Start the engine/motor.

**! CAUTION!** Avoid operating the power feed for prolonged periods without the engine running. Battery drainage will result.

2. With the carriage forward/reverse switch in the neutral (middle as shown), flip the power toggle switch on the control to the on (#1) position. The power indicator light will illuminate.

**! WARNING!** Be sure the forward/reverse switch is in the neutral position before turning the power switch to the on (#1) position. This prevents accidental carriage movement which may cause serious injury or death.

The power feed system moves the carriage forward and backward by using two switches on the control panel.

#### Carriage Feed Rate

The carriage feed rate switch controls the speed at which the carriage travels forward. Turn the switch clockwise to increase speed. Turn it counterclockwise to reduce speed.

#### Carriage Forward and Reverse

The carriage forward/reverse switch controls the direction in which the carriage travels.

1. Push the forward/reverse switch handle upward to move the carriage forward.
2. Push the switch handle down to move the carriage backward.

The middle position (as shown) is the neutral position. The power feed switch is designed to return to the neutral or "off" position when released from operating in the reverse position. If the switch remains engaged, manually move the switch to the neutral or "off" position and repair the drum switch.

3. Turn the feed rate switch all the way down before engaging the forward/reverse switch in the forward position.
4. Push the forward/reverse switch forward (upward) and slowly turn up the feed rate switch to move the carriage forward until the blade is positioned at the end of the log.
5. Release the forward/reverse switch to neutral and turn the feed rate switch all the way down.
6. Raise or lower the saw head until the blade is positioned for the first cut and start the blade.
7. Push the forward/reverse switch forward and slowly turn up the feed rate switch to start the blade into the log.

**TIP:** To get a straight cut in the first part of the board, feed the blade into the log at a slow speed. This stops the blade from flexing and dipping up or down. Use a slow speed until the whole width of the blade has entered the cut. Then increase the feed rate as desired. Maximum feed rate varies with width and hardness of the wood. Over-feeding results in engine and blade wear, and also produces a wavy cut.

8. Release the forward/switch to neutral to stop the carriage at the end of the cut.
9. Disengage the blade and drop the engine to idle.
10. Remove the board from the top of the log.

**! CAUTION!** Be sure to stop the blade when returning the carriage. This will not only prevent the blade from being pulled off and ruined by a wood sliver, but also will increase the life of the blade.

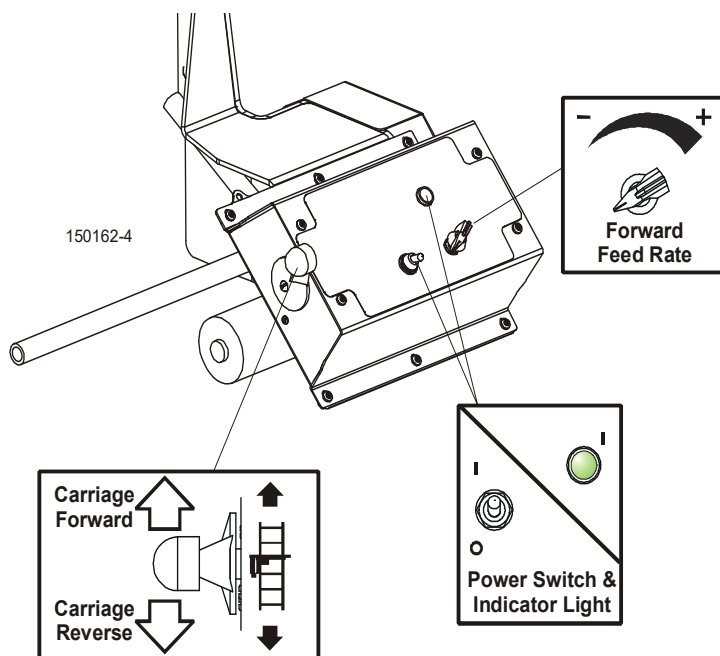

FIG. 2-1

11. Make sure that the blade does not catch on the end of the log.

**TIP:** Try to stop the blade while the heel of the blade is still on the log. Then bring the carriage back without adjusting the blade up. This lets you keep the blade at the current height setting so you can make the next blade height adjustment more quickly. If the blade starts to catch on the log, raise the saw head slightly clear any obstructions when returned.

12. Return the carriage to the front of the mill by pushing the forward/reverse switch handle down.

The power feed motor will bypass the carriage feed rate switch and the carriage will automatically return at the fastest speed available.

13. Set the power toggle switch to the off (#0) position when not using the power feed.

## 2.2 Maintenance

**WARNING!** Disconnect and lockout power before performing any service to the electrical system. For battery-powered equipment, disconnect the negative battery terminal cable. Failure to do so may result in injury and/or electrical system damage.

**50** Lubricate the power feed drum switch contacts inside the control panel every fifty hours of operation. Use only contact grease supplied by Wood-Mizer. Remove the control panel cover. Use a cotton swab to apply grease to the switch contact ends.

**WARNING!** Drum switch grease contains Petroleum Hydrocarbon Lubricant. Eye and skin irritant. If introduced into eyes, flush with water for at least 15 minutes. If film or irritation persists, seek medical attention. Wash skin with soap and water. If ingested, do not induce vomiting - contact a physician. KEEP OUT OF THE REACH OF CHILDREN.

**Gas/Diesel Models Only:** The power feed control is protected with a 40 amp fuse located in the harness that connects to the battery. If the power feed does not have power, check and replace this fuse if necessary.

## 2.3 Troubleshooting

### LT15PF Power Feed

#### The saw head will not go forward or reverse:

1. Check voltage across B+ (BAT) and B- (NEG) of the control board for 12VDC.
2. If there is no voltage, verify the toggle switch is in the on position and 12VDC is present on both terminals.
3. If 12VDC is good, check voltage across 0V and 5V terminals for 5VDC.
4. If there is no voltage or low voltage, replace the control board (Part No. 057829-FR).
5. If 5VDC is good, with the drum switch in the neutral position check voltage across the drum switch terminals 2 and 6 for 5VDC.
6. If there is no voltage, check for broken finger or bad connections from the drum switch terminals 2 and 6 to the control board.
7. If 5VDC is good, check voltage across the drum switch terminals 2 and 4 for 2.5VDC.
8. If there is no voltage, check for broken drum switch finger or bad connections from drum switch terminals 2 and 4 to the control board.

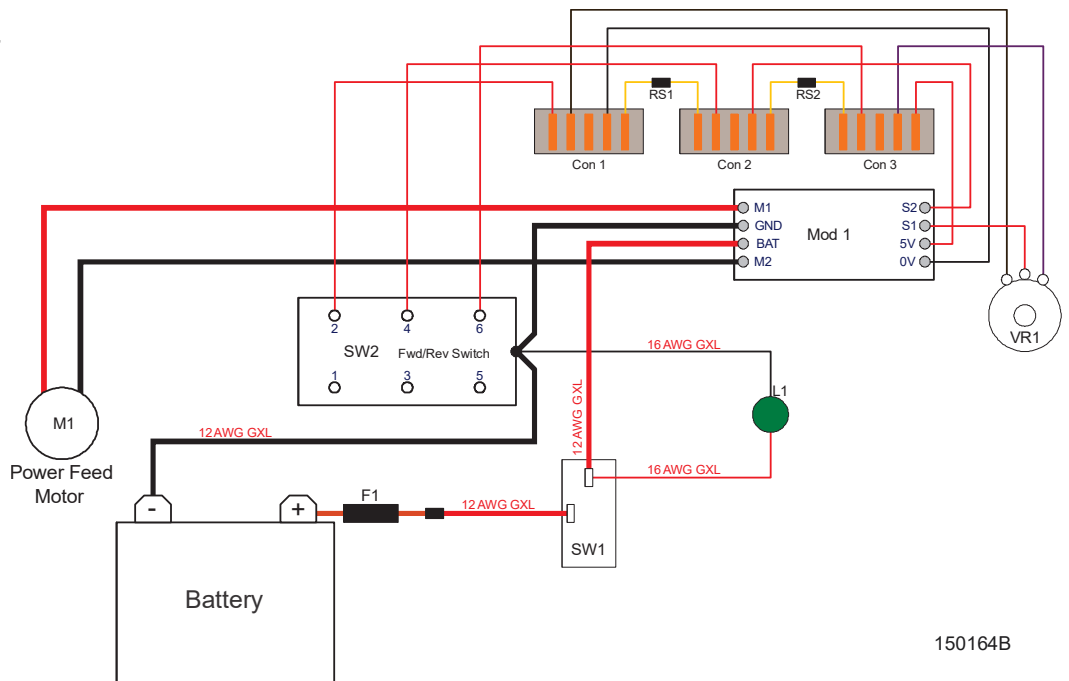

150164B

**FIG. 2-2**

9. If 2.5VDC is good, with the drum switch in the neutral position, check voltage on S2 of the control board for 2.5VDC.
10. If there is no voltage, check connections between CON2 and the control board.
11. If 2.5VDC is good, put the drum switch in reverse.
12. Check voltage on S2 terminal for 5.0VDC
13. If there is no voltage, check connections between CON2 and the control board.
14. If 5VDC is good, check voltage across the M1 and M2 terminals of the control board. The reading should be 12VDC.
15. If there is no voltage, replace the control board (Part No. 057829-FR).
16. If 12VDC is good, check connections at the PF motor and motor.

***The saw head will not go in reverse:***

1. Put the drum switch in reverse.
2. Check voltage on S2 terminal for 5.0VDC.
3. If there is no voltage, check connections between CON2 and the control board.
4. If 5VDC is good, check voltage across the M1 and M2 terminals of the control board for 12VDC.
5. If there is no voltage, replace the control board (Part No. 057829-FR).
6. If 12VDC is good, check connections at the PF motor and motor.

***The saw head will not go forward:***

1. Put the drum switch in forward.
2. Check voltage on S2 terminal for 0VDC.
3. If voltage is shown, check connections between CON2 and the control board.
4. If 0VDC is good, check voltage on the S1 terminal of the control board. As you turn the variable feed switch from slow to fast, the voltage reading should go from 0VDC to 5VDC.
5. If there is no voltage, check the variable feed switch function.
6. If 0VDC to 5VDC is good, check voltage across the M1 and M2 terminals of the control board. Using a test light, it should get dim to bright as you turn the variable feed switch from slow to fast.
7. If there is no variation, replace the control board (Part No. 057829-FR).
8. If variation is good, check connections at the PF motor and motor.

## **2.4 LT15SPF/LT15LHPF Power Feed**

***The saw head will not go forward or reverse:***

1. Verify 230VAC single phase across terminals L (wire 407) and N (wire 406) of the PWR2 power supply.
2. If there is no voltage, check for blown F7 and F8 fuses.
3. If 230VAC single phase is good, verify 12VDC across V+ (wire 15) and V- (wire 13) of the PWR2 power supply.



4. If there is no voltage, replace PWR2 power supply.

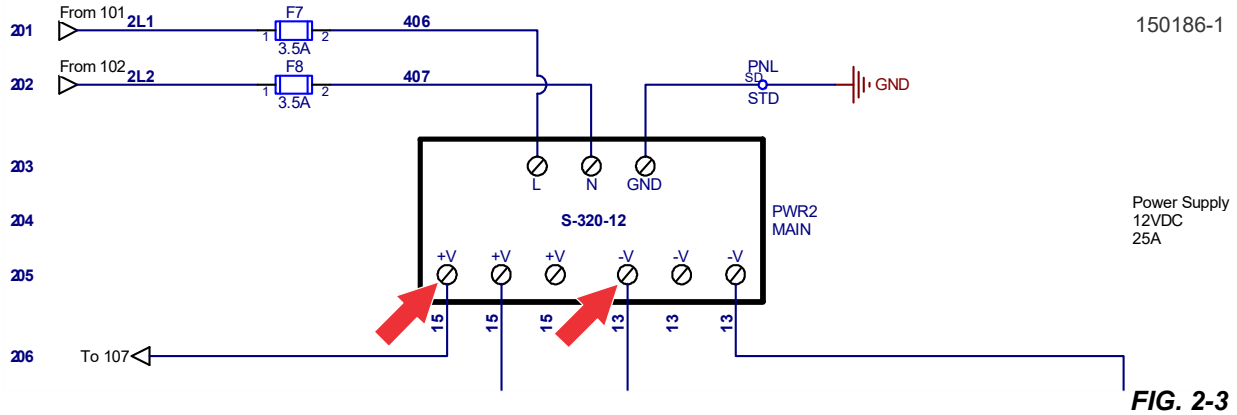

5. If 12VDC is good, verify 12VDC across L3 (wire 15) of the C1 contactor and V- (wire 13) of the PWR2 power supply.

6. If there is no voltage, check for band connection between L3 and V-.

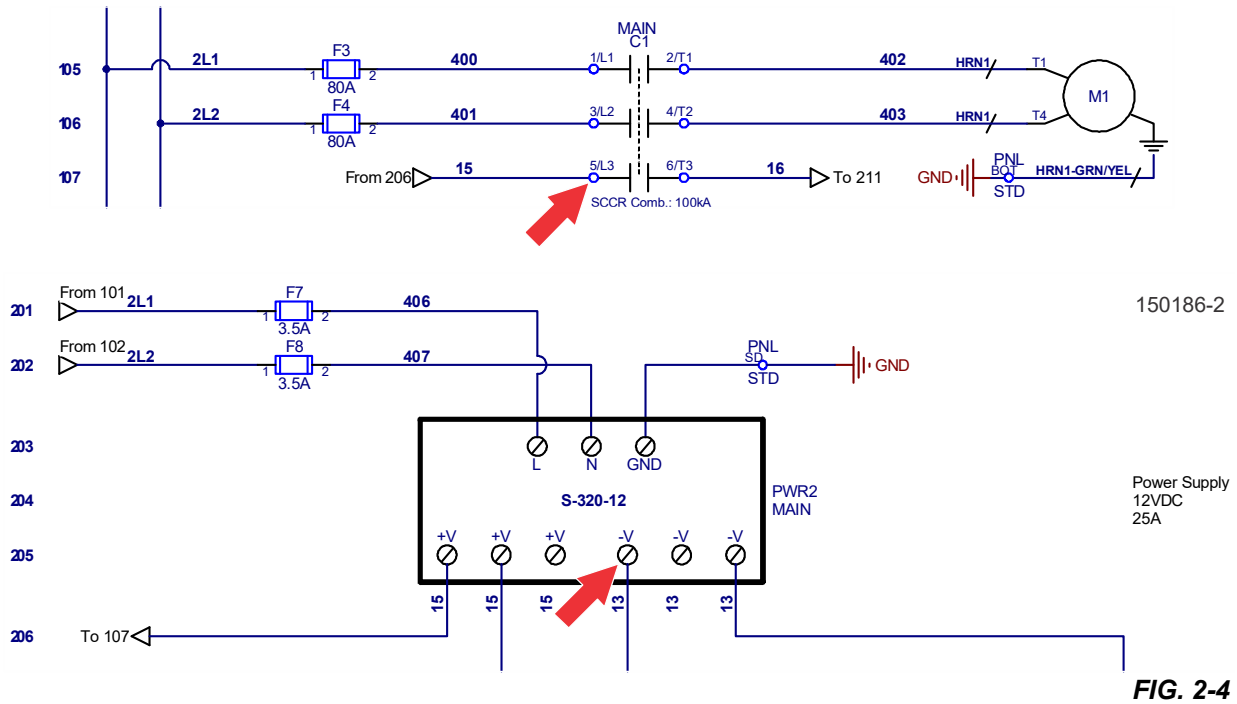

7. If 12VDC is good, verify 12VDC across T3 (wire 16) of the C1 contactor and V- (wire 13) of the PWR2 power supply.

8. If there is no voltage, replace C1 contactor.

## 2 Operation, Maintenance & Troubleshooting

9. If 12VDC is good, follow LT15PF instructions.

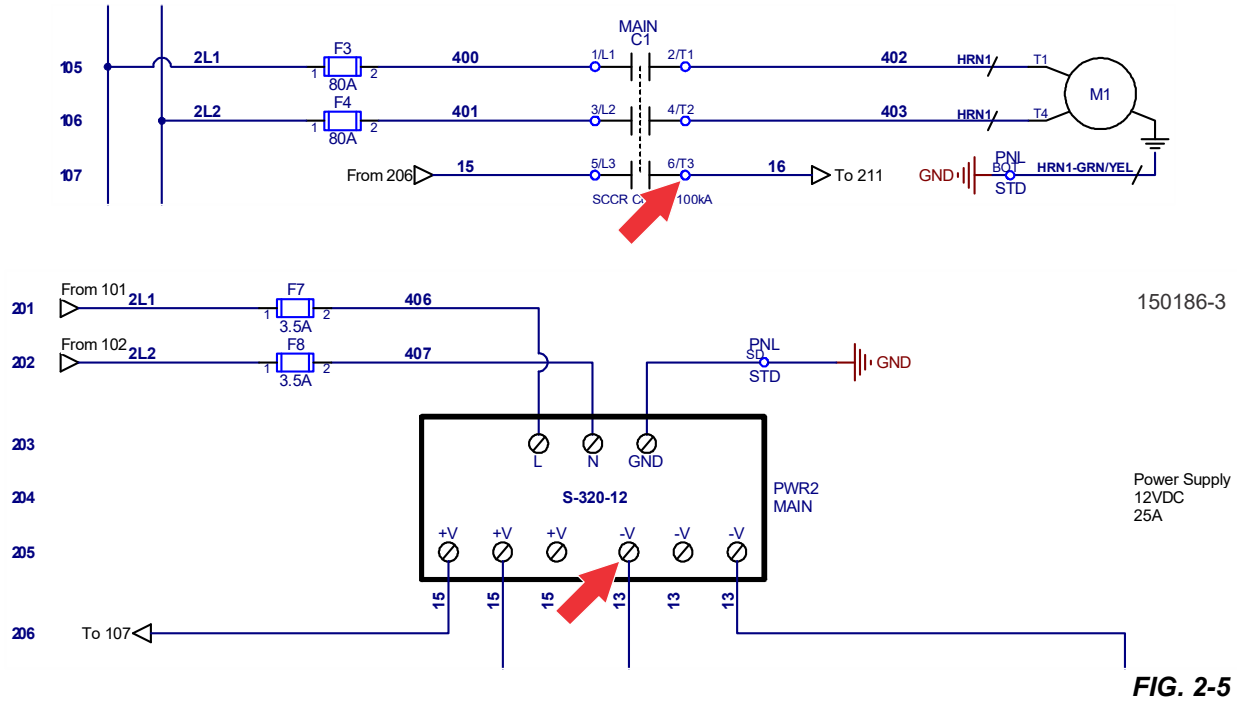
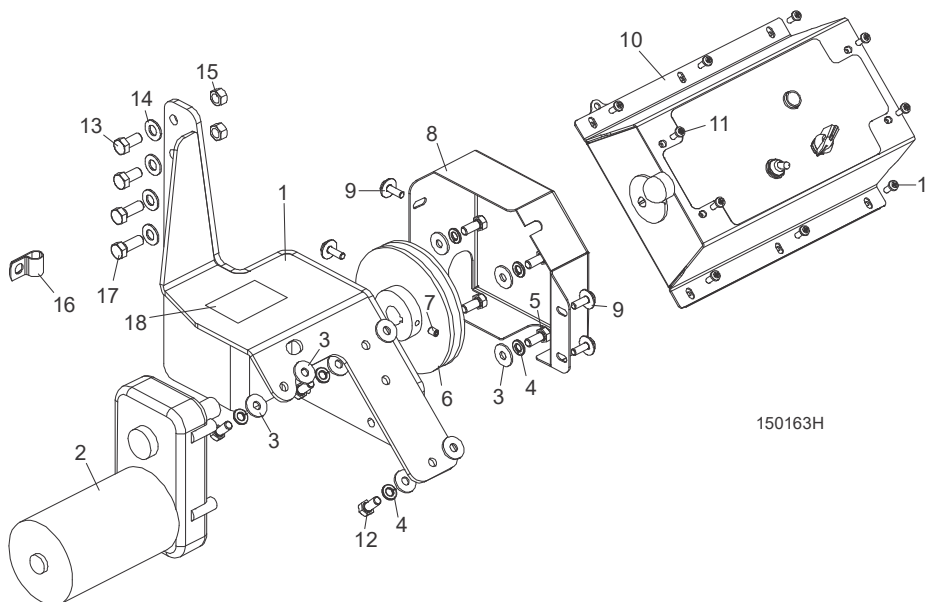

FIG. 2-5

## SECTION 3 REPLACEMENT PARTS

### 3.1 Power Feed Complete (LT15PF)



REF	PART #	DESCRIPTION	COMMENTS	QTY.
	LT15PF	<b>KIT, LT15 POWER FEED</b>		1
	056967	Control Assembly, LT15 Power Feed		1
<b>1</b>	056968	Bracket Weldment, Power Feed Mount		1
<b>2</b>	133256	Gearmotor, Klauber 1/5HP 87RPM 12VDC		1
	133398	Kit, 133256 Gearmotor Brush Replacement		1
<b>3</b>	F05011-16	Washer, 5/16" Standard Flat		10
<b>4</b>	F05011-13	Washer, 5/16" Split Lock		7
<b>5</b>	F05006-102	Bolt, 5/16-18 x 3/4" Hex Head Grade 5		4
<b>6</b>	056802	Pulley, Feed Rope		1
<b>7</b>	F05005-47	Screw, 1/4-20 x 3/8" Cup Point Socket Set		1
<b>8</b>	056970	Plate, Feed Pulley Cover		1
<b>9</b>	F05005-134	Screw, 1/4-20 x 3/4" Hex w/Conical Washer Head		4
<b>10</b>	110009	Control Assembly, LT15 Power Feed ( )	<a href="#">See Section 3.5</a> Replaces 056969 LT15 Power Feed Control Assembly (See Section 3.7) to improve durability (Rev. B.00).	1
<b>11</b>	F05015-17	Bolt, #10-24 x 1/2" Phillips Pan Head		10
<b>12</b>	F05006-5	Bolt, 5/16-18 x 3/4" Hex Head		3
<b>13</b>	F05007-118	Bolt, 3/8-16 x 3/4" Hex Head Grade 5		2
<b>14</b>	F05011-3	Washer, 3/8" SAE Flat		4
<b>15</b>	F05010-1	Nut, 3/8-16 Hex		2
<b>16</b>	P07584	Clamp, 1/2" EMT Coated	Added 2/10 to secure power harness to battery box mount.	1
<b>17</b>	F05007-87	Bolt, 3/8-16 x 1" Hex Head Grade 5		2
<b>18</b>	074621	Decal, Keep Rope Tight		1
	N/A	Rope Adjustment Bracket	<a href="#">See Section 3.8</a>	1
	M1539	Option Manual, LT15 Power Feed		1

### 3.2 Power Feed Complete (LT15E10SPF)

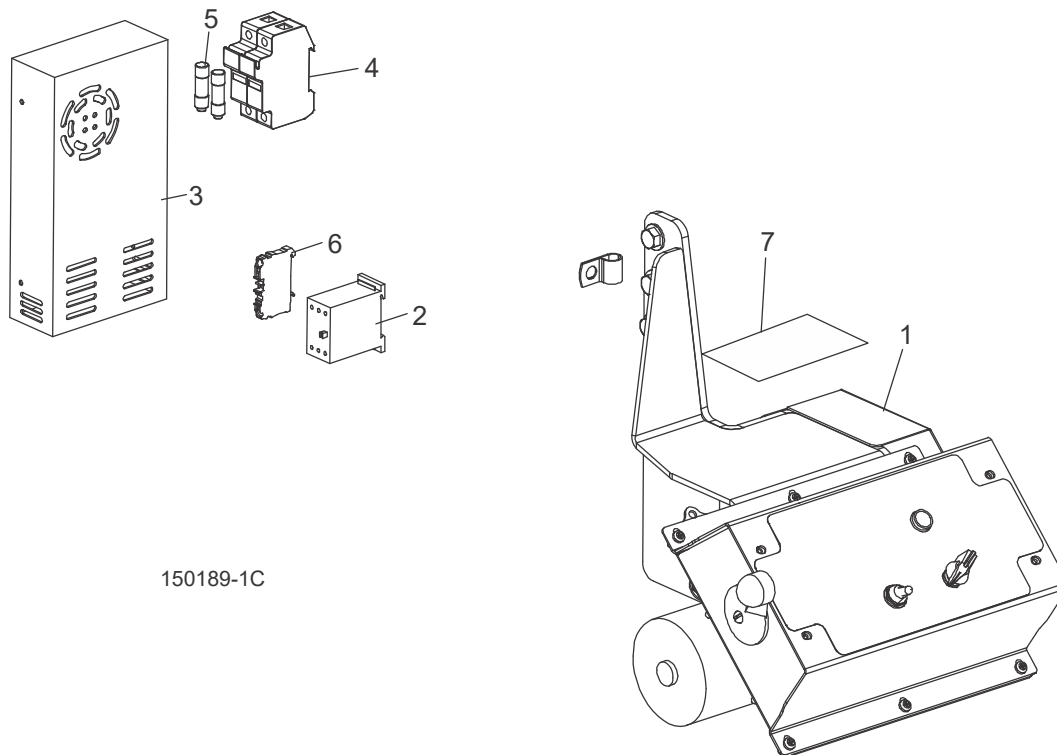

150189-1C

REF	PART #	DESCRIPTION	COMMENTS	QTY.
	LT15E10SPF	<b>KIT, LT15E10S POWER FEED</b>		1
	069373	Control Assembly, LT15E10S Power Feed		1
<b>1</b>	N/A	Motor/Operator Control Parts	<a href="#">See Section 3.4</a>	1
<b>2</b>	053590	Relay, 12VDC 2NO Control		1
<b>3</b>	053592	Power Supply, 12VDC 320W Chassis Mount		1
<b>4</b>	052512	Fuse Block, 2P Class CC 30A DIN Mount		1
<b>5</b>	052721	Fuse, 3.5A 600V Class CC Delay		2
<b>6</b>	068106	Terminal Block, 2Pos 4mm Clamp		1
<b>7</b>	074621	Decal, Keep Rope Tight		1
	N/A	Rope Adjustment Bracket	<a href="#">See Section 3.8</a>	1
	M1539	Option Manual, LT15 Power Feed		1

### 3.3 Power Feed Complete(LT15E10LHPF)

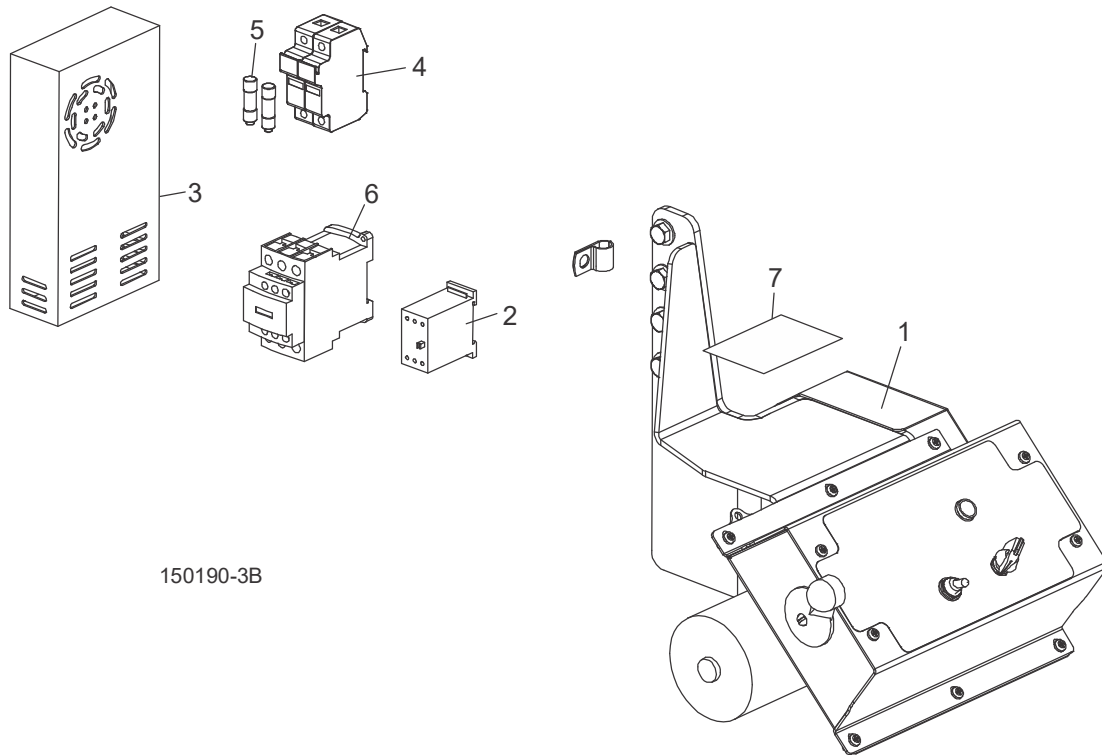

150190-3B

REF	PART #	DESCRIPTION	COMMENTS	QTY.
	LT15E10LHPF	<b>KIT, LT15E10L/LT15E10H POWER FEED</b>		1
	069375	Control Assembly, LT15E10S Power Feed		1
<b>1</b>	N/A	Motor/Operator Control Parts	<a href="#">See Section 3.4</a>	1
<b>2</b>	053590	Relay, 12VDC 2NO Control		1
<b>3</b>	053592	Power Supply, 12VDC 320W Chassis Mount		1
<b>4</b>	052512	Fuse Block, 2P Class CC 30A DIN Mount		1
<b>5</b>	052721	Fuse, 3.5A 600V Class CC Delay		2
<b>6</b>	052465	Contactor, 32A 3P 24VDC Coil		1
<b>7</b>	074621	Decal, Keep Rope Tight		1
	N/A	Rope Adjustment Bracket	<a href="#">See Section 3.8</a>	1
	M1539	Option Manual, LT15 Power Feed		1

### 3.4 Power Feed Motor/Control (E10)

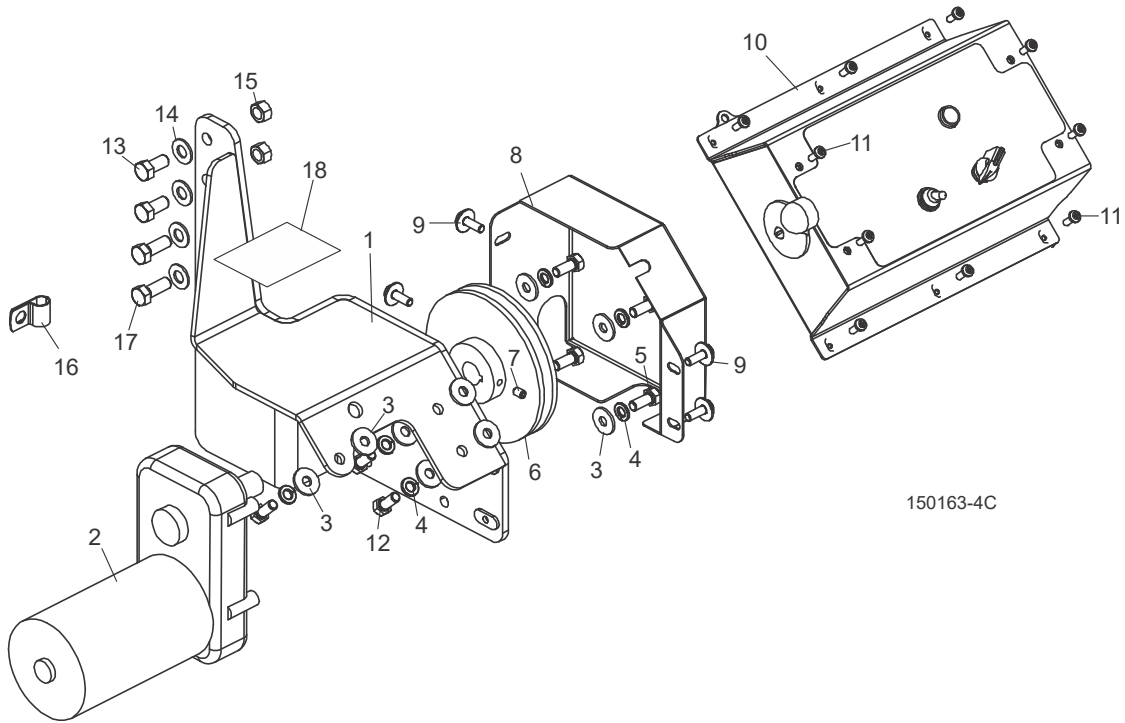

REF	PART #	DESCRIPTION	COMMENTS	QTY.
1	056968	BRACKET WELDMENT, POWER FEED MOUNT		1
2	133256	Gearmotor, Klauber 1/5HP 87RPM 12VDC		1
	133398	Kit, 133256 Gearmotor Brush Replacement		1
3	F05011-16	WASHER, 5/16" STANDARD FLAT		10
4	F05011-13	WASHER, 5/16" SPLIT LOCK		7
5	F05006-102	BOLT, 5/16-18 X 3/4" HEX HEAD GRADE 5		4
6	056802	PULLEY, FEED ROPE		1
7	F05005-47	SCREW, 1/4-20 X 3/8" CUP POINT SOCKET SET		1
8	056970	PLATE, FEED PULLEY COVER		1
9	F05005-134	SCREW, 1/4-20 X 3/4" HEX W/CONICAL WASHER HEAD		4
10	110010	CONTROL ASSEMBLY, LT15E10 POWER FEED <i>(See Section 3.6)</i>	Replaces 053703 LT15 Power Feed Control Assembly w/053708 LT15E10 Power Feed Harness Assembly to improve durability (LT15E10SPF Rev. C.00/LT15E10LHPF Rev. B.00).	1
11	F05015-17	BOLT, #10-24 X 1/2" PHILLIPS PAN HEAD		10
12	F05006-5	BOLT, 5/16-18 X 3/4" HEX HEAD		3
13	F05007-118	BOLT, 3/8-16 X 3/4" HEX HEAD GRADE 5		2
14	F05011-3	WASHER, 3/8" SAE FLAT		4
15	F05010-1	NUT, 3/8-16 HEX		2
16	P07584	CLAMP, 1/2" EMT COATED		1
17	F05007-87	BOLT, 3/8-16 X 1" HEX HEAD GRADE 5		2
18	074621	DECAL, KEEP ROPE TIGHT		1
	N/A	ROPE ADJUSTMENT BRACKET	<i>See Section 3.8</i>	1
	M1539	OPTION MANUAL, LT15 POWER FEED		1

### 3.5 Operator Control (All Except E10)

LT15PF Rev. B.00+

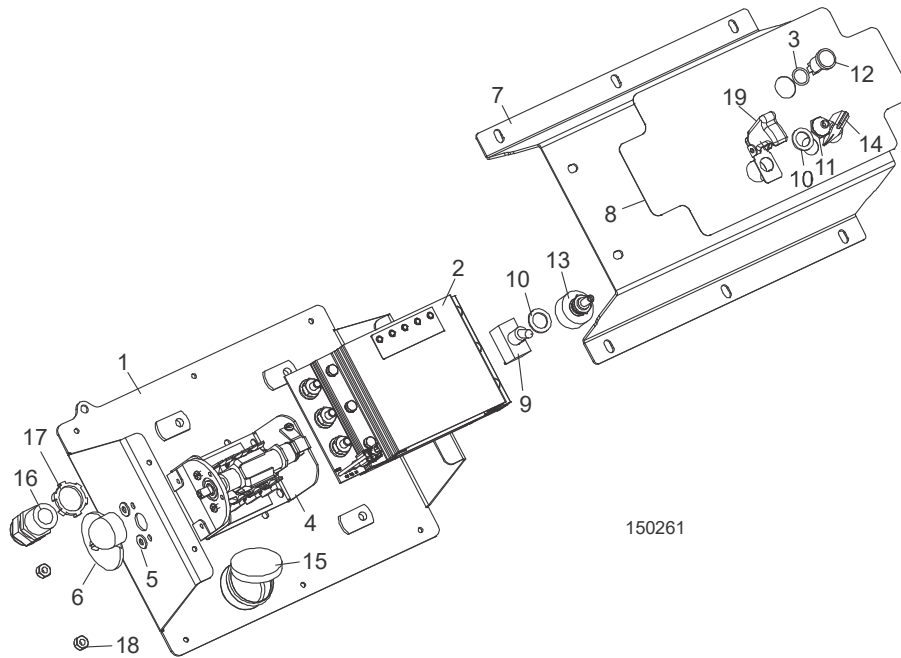

REF	PART #	DESCRIPTION	COMMENTS	QTY.
	110009	<b>OPERATOR ASSEMBLY, LT15 POWER FEED W/O HARNESS</b>		1
	110008	Operator Assembly, 2017 LT15PF w/o Harness		1
<b>1</b>	110006	Weldment, 2017 LT15/28 PF Control Bottom		1
<b>2</b>	073547	Control Module, Power Feed with Heatsink		1
<b>3</b>	050369	O-Ring, 3/8" Dia. Neoprene		1
<b>4</b>	E20439	Switch, Power Feed Drum		1
<b>5</b>	F05011-41	Washer, #8 SAE Flat		2
<b>6</b>	P12500	Handle, Drum Switch w/Screw		1
<b>7</b>	110005	Plate, 2017 LT15/28 PF Control Top		1
<b>8</b>	056964	Decal, LT15 Power Feed Control		1
<b>9</b>	053695	Switch, SPST 25A Toggle		1
<b>10</b>	P05251-1	Washer, 1/2" x 3/4" x 1/16" Nylon		2
<b>11</b>	P02575	Boot, Toggle Switch		1
<b>12</b>	E20483	Light, Green 12V .187 Tabs		1
<b>13</b>	A07793	Pot Assembly, Feed Rate Control		1
<b>14</b>	P06257	Knob, Feed Rate Control		1
<b>15</b>	A20463	Grease, Drum Switch		1
<b>16</b>	051299	Connector, 1/2" NPT .17-.47		1
<b>17</b>	E20461	Nut, 1/2 NPT Connector Lock		1
<b>18</b>	F05010-160	Nut, 10-24 Hex Nylock		4
<b>19</b>	114034	Cover, Toggle Safety Switch - Orange	Cover added after 7/6/2020.	1
	073644	Harness, LT15G/D PF Battery		1
	052164	Fuseholder, ATO 12AWG Radial Lead		1
	024150-40	Fuse, 40A ATO Orange Blade		1

### 3.6 Operator Control (E10 Only)

*LT15PFE10SPF Rev. C.00+*

*LT15LHPF Rev. B.00+*

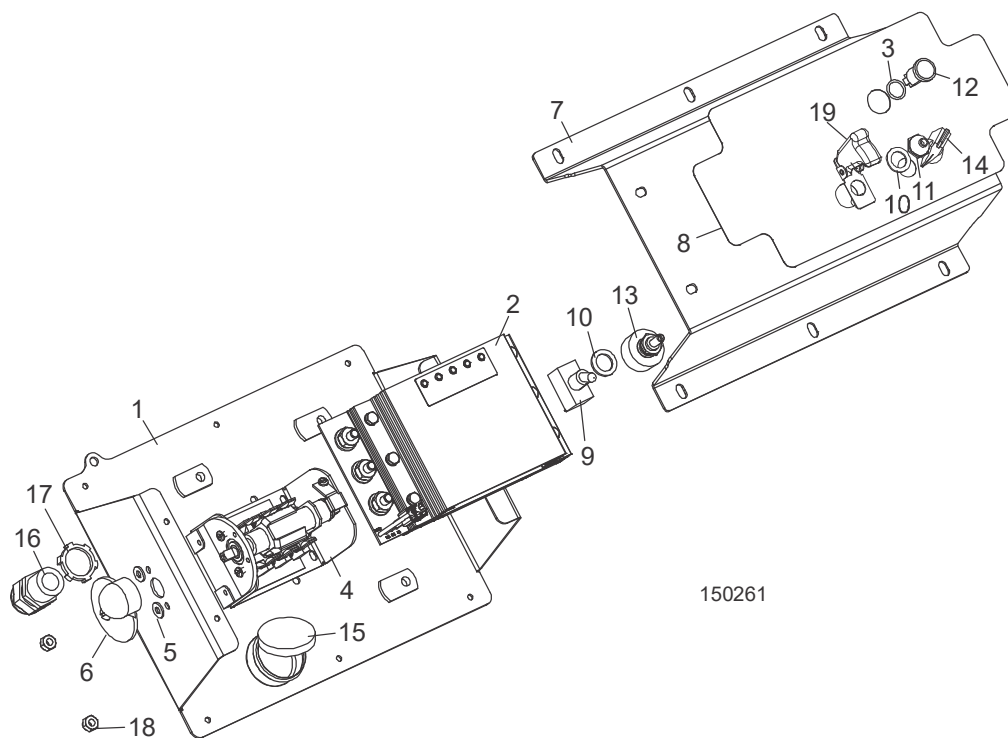

REF	PART #	DESCRIPTION	COMMENTS	QTY.
	110010	<b>OPERATOR ASSEMBLY, 2017 LT15E10 POWER FEED</b>		1
	110008	Operator Assembly, 2017 LT15PF w/o Harness		1
<b>1</b>	110006	Weldment, 2017 LT15/28 PF Control Bottom		1
<b>2</b>	073547	Control Module, Power Feed with Heatsink		1
<b>3</b>	050369	O-Ring, 3/8" Dia. Neoprene		1
<b>4</b>	E20439	Switch, Power Feed Drum		1
<b>5</b>	F05011-41	Washer, #8 SAE Flat		2
<b>6</b>	P12500	Handle, Drum Switch w/Screw		1
<b>7</b>	110005	Plate, 2017 LT15/28 PF Control Top		1
<b>8</b>	056964	Decal, LT15 Power Feed Control		1
<b>9</b>	053695	Switch, SPST 25A Toggle		1
<b>10</b>	P05251-1	Washer, 1/2" x 3/4" x 1/16" Nylon		2
<b>11</b>	P02575	Boot, Toggle Switch		1
<b>12</b>	E20483	Light, Green 12V .187 Tabs		1
<b>13</b>	A07793	Pot Assembly, Feed Rate Control		1
<b>14</b>	P06257	Knob, Feed Rate Control		1
<b>15</b>	A20463	Grease, Drum Switch		1
<b>16</b>	051299	Connector, 1/2" NPT .17-.47		1
<b>17</b>	E20461	Nut, 1/2 NPT Connector Lock		1
<b>18</b>	F05010-160	Nut, 10-24 Hex Nylock		4



REF	PART #	DESCRIPTION	COMMENTS	QTY.
<b>19</b>	114034	Cover, Toggle Safety Switch - Orange	Cover added after 7/6/2020.	1
	073646	Harness Assembly, LT15E10 PF		1
	050202	Conn, Flex 90 .125 - .375 Cord 1/2 Hub		1
	E20460	Ring, 1/2 Sealing		1
	051299	Connector, 1/2" NPT .17-.47		1
	E20461	Nut, 1/2 npt Connector Lock		2
	R02373	Conduit, 3/8" Expandable Black		53 in

### 3.7 Operator Control (All LT15)

*LT15PF Prior to Rev. B.00*

*LT15PFE10SPF Prior to Rev. C.00*

*LT15LHPF Prior to Rev. B.00*

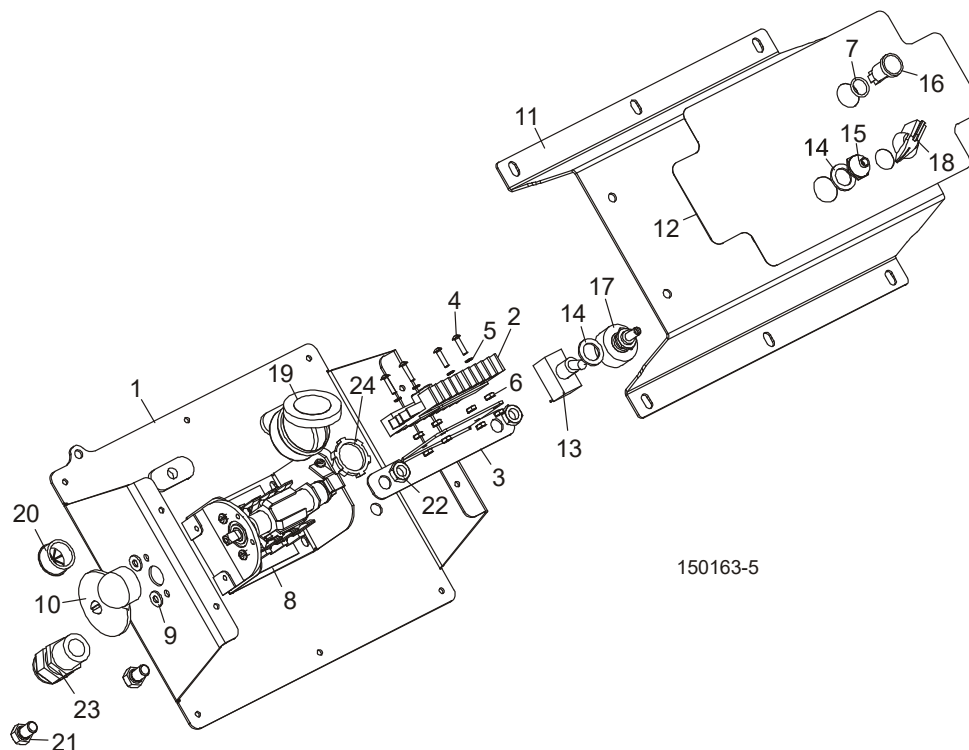

REF	PART #	DESCRIPTION	COMMENTS	QTY.
	056969	<b>OPERATOR ASSEMBLY, LT15 POWER FEED</b>		1
	053709	Operator Assembly, Lt15 Power Feed w/o Harness		1
<b>1</b>	008954	Plate, Control Box Bottom		1
<b>2</b>	057829-FR	Driver Kit, 25A DC Motor Field Replacement	Field Replacement Kit 057829-FR replaces Driver Module 057829 originally supplied prior to 1/10. Module B-, B+, M1 & M2 connections changed from terminal block to spade terminal to allow 3r wiring size to be used. Kit includes new driver module w/spade terminals, quick connect terminals and instructions.	1
	057975	Retrofit Kit, LT15PF Control Box	Module Bracket and O-Ring added Rev. A.01. Bracket mounts driver module vertically to prevent water from collecting on circuit board. O-Ring around light prevents water from entering the control box assembly. Use kit 057975 to retrofit previous revisions.	1

REF	PART #	DESCRIPTION	COMMENTS	QTY.
3	056993	Bracket, Module Mount		1
4	F05004-14	Screw, #4-40 x 1/2" Slotted Round Head		4
5	F05011-21	Washer, #4 Split Lock		4
6	F05010-43	Nut, #4-40 Hex		8
7	050369	O-Ring, 3/8" Dia. Neoprene		1
	057975-1568	Inst. Sheet, LT15PF Control Retrofit		1
8	E20439	Switch, Power Feed Drum		1
9	F05011-41	Washer, #8 SAE Flat		2
10	P12500	Handle, Drum Switch w/Screw		1
11	056950	Plate, Control Box Cover		1
12	056964	Decal, LT15 Power Feed Control		1
13	053695	Switch, SPST 25A Toggle		1
14	P05251-1	Washer, 1/2" x 3/4" x 1/16" Nylon		2
15	P02575	Boot, Toggle Switch		1
16	E20483	Light, Green 12V .187 Tabs		1
17	A07793	Pot Assembly, Feed Rate Control	Replaced Feed Rate Control Pot Switch Assembly 024450-1 (3/12).	1
18	P06257	Knob, Feed Rate Control		1
19	A20463	Grease, Drum Switch		1
20	P04137	Grommet, 5/8" Wire		1
21	F05006-15	Bolt, 5/16-18x1/2 HH Gr5		2
22	F05010-121	Nut, 5/16-18 Nylon Locking Jam		2
23	051299	Connector, 1/2" NPT .17-.47		1
24	E20461	Nut, 1/2 NPT Connector Lock		1
	052293-5	Junction Block, 5-Position Wire Clamp		3
	053200	Resistor Assembly, 1K w/6" Yellow Wires		2
	053707	Harness Assembly, LT15 Power Feed (Gas/Diesel)		1
	052164	Fuseholder, ATO 12AWG Radial Lead		1
	024150-40	Fuse, 40A ATO Orange Blade		1
	R02374	Conduit, 1/2" Expandable Black		2.5 ft.

### 3.8 Rope Adjustment Bracket

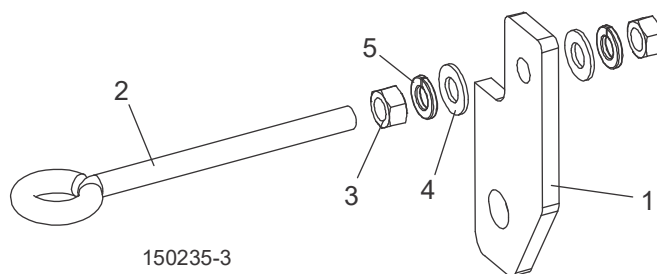

REF	PART #	DESCRIPTION	COMMENTS	QTY.
1	076625	BRACKET, ROPE ADJUSTMENT	Added to allow for feed rope to be adjusted to prevent slipping (Rev. A.04).	1
2	F05006-132	BOLT, 5/16-18 X 4" EYE		1
3	F05010-17	NUT, 5/16-18 HEX		2
4	F05011-17	WASHER, 5/16" SAE FLAT		2
5	F05011-13	WASHER, 5/16" SPLIT LOCK		2

## SECTION 4 ELECTRICAL INFORMATION

### 4.1 Wiring Diagram (Gas/Diesel LT15)

LT15PF Rev. B.00+  
 LT15PFE10SPF Rev. C.00+  
 LT15LHPF Rev. B.00+

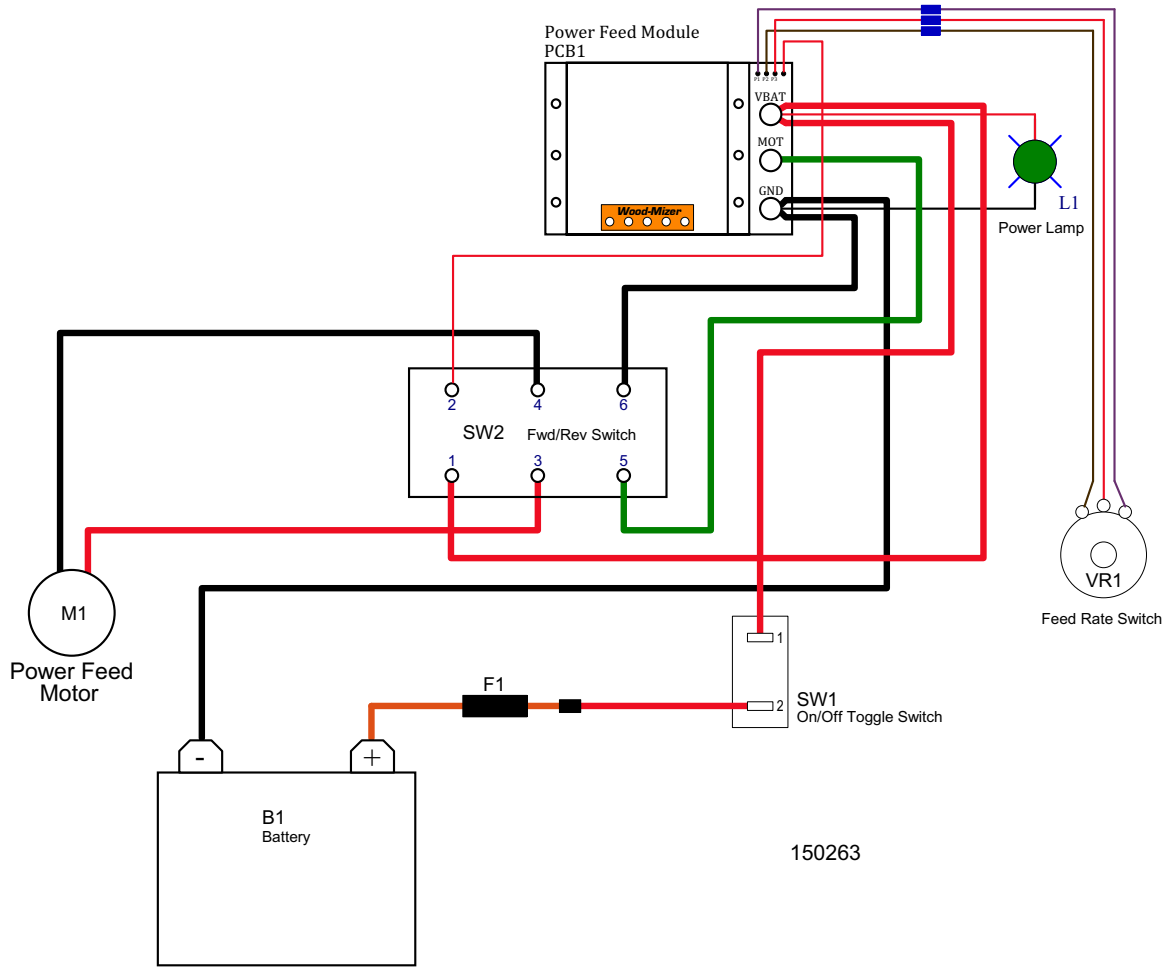

150263

FIG. 4-1

**4.2 Wiring Diagram (Gas/Diesel LT15)**

*LT15PF Prior to Rev. B.00  
 LT15PFE10SPF Prior to Rev. C.00  
 LT15LHPF Prior to Rev. B.00*

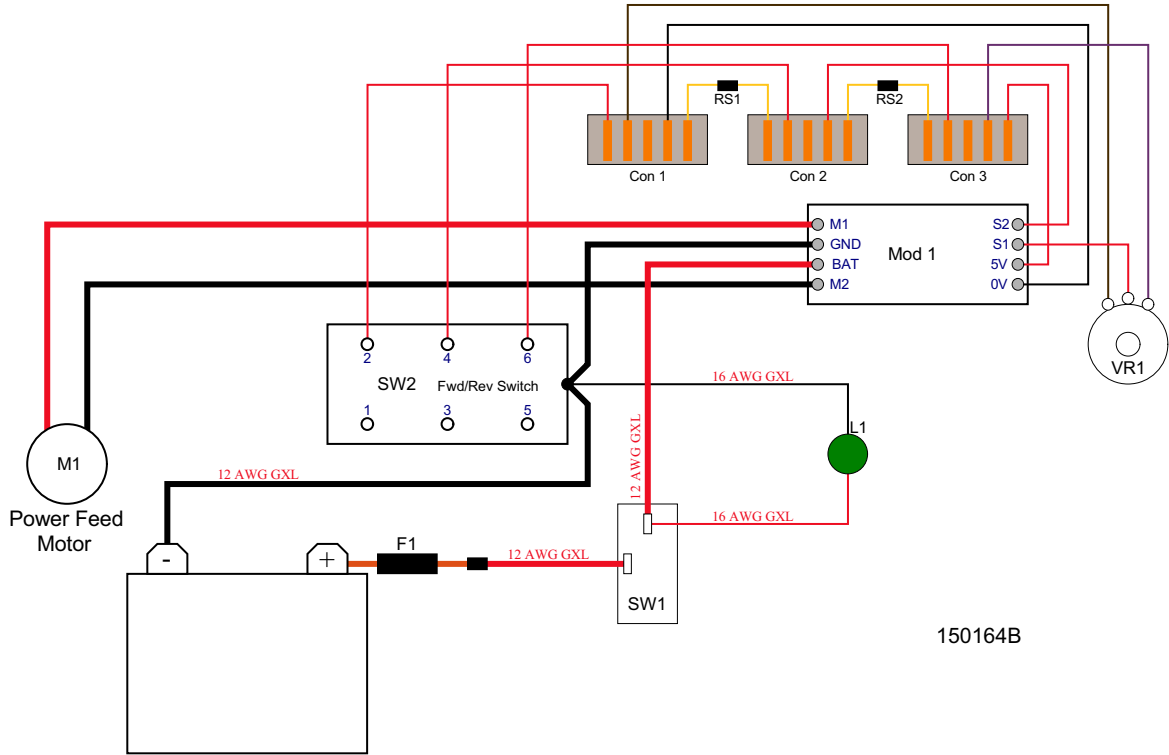

**FIG. 4-2**

### 4.3 Wiring Diagram (LT15E10S) LT15E10S Rev. A.03+

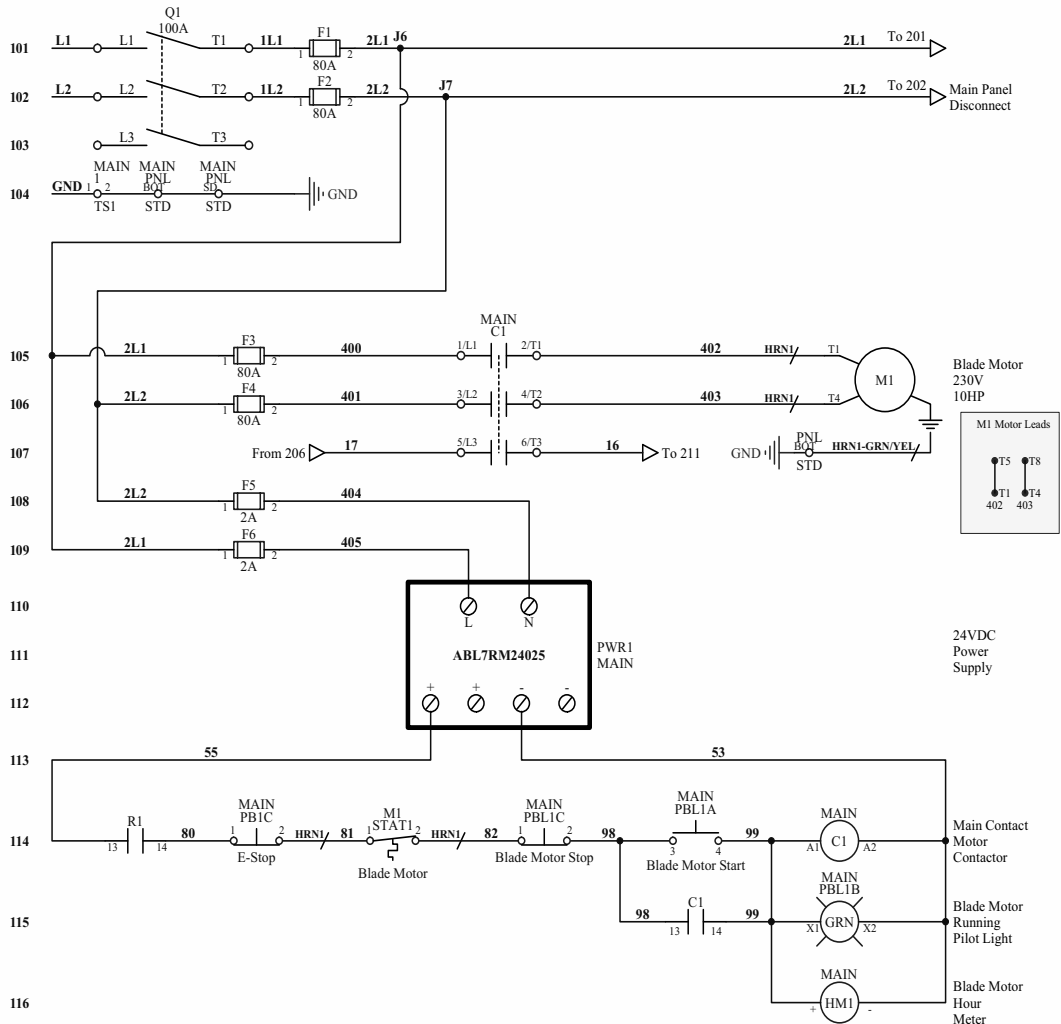

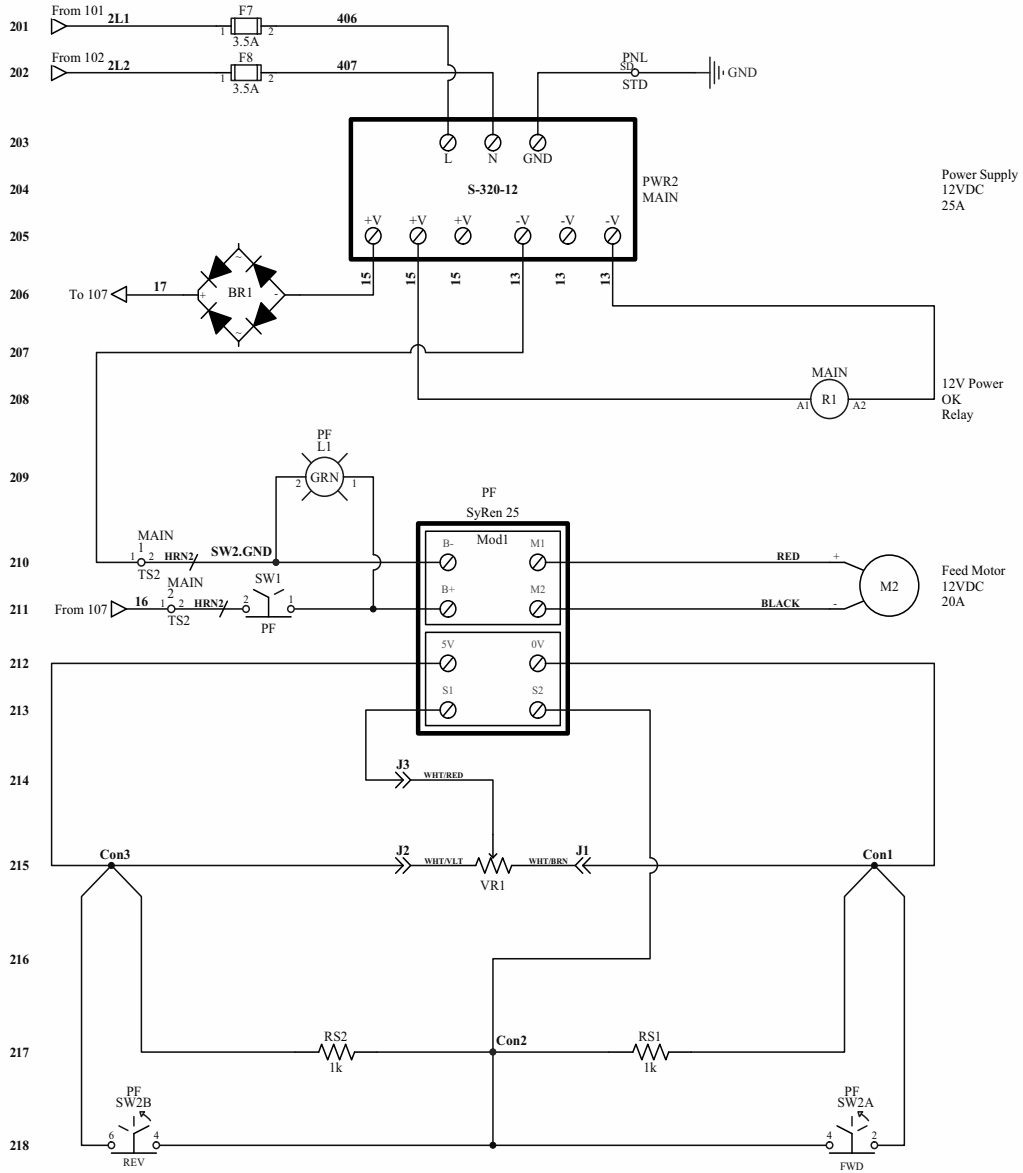

SW2						
Position	Contacts					
FWD	A	A	B	A	B	
N						
REV	A		A	B	B	



4.4 Wiring Diagram (LT15E10S)  
LT15E10S Rev. A.00 - A.02

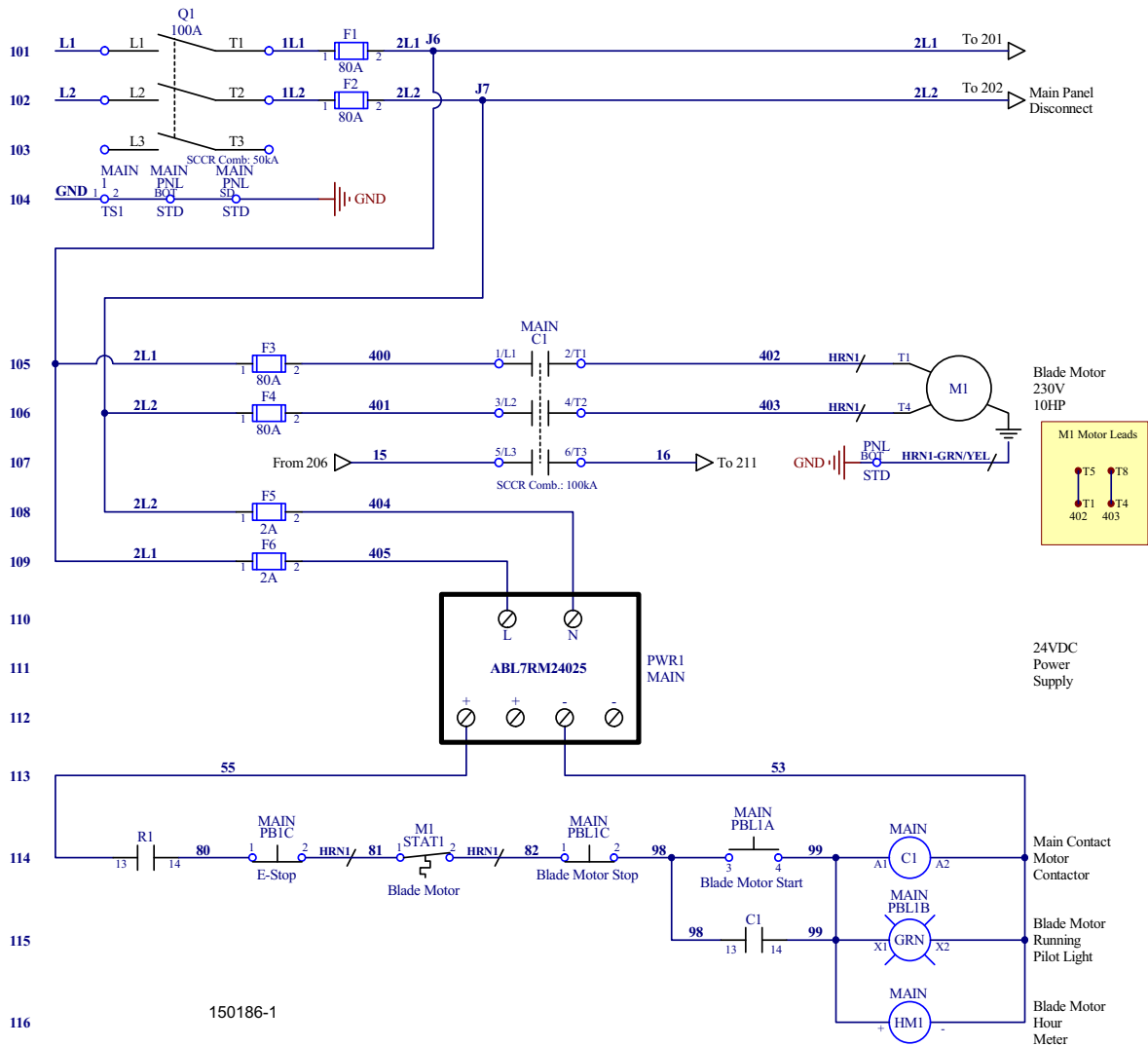
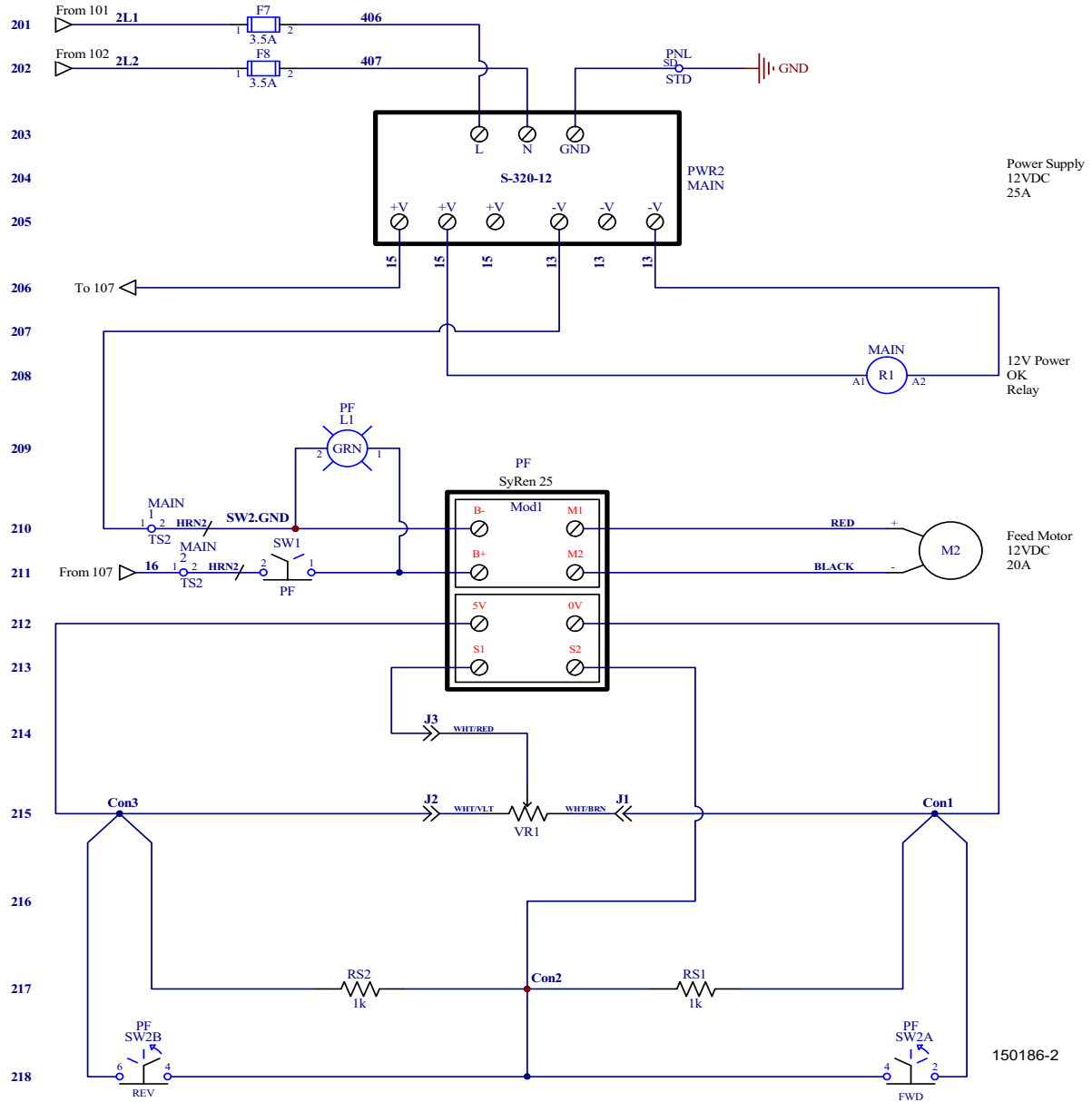
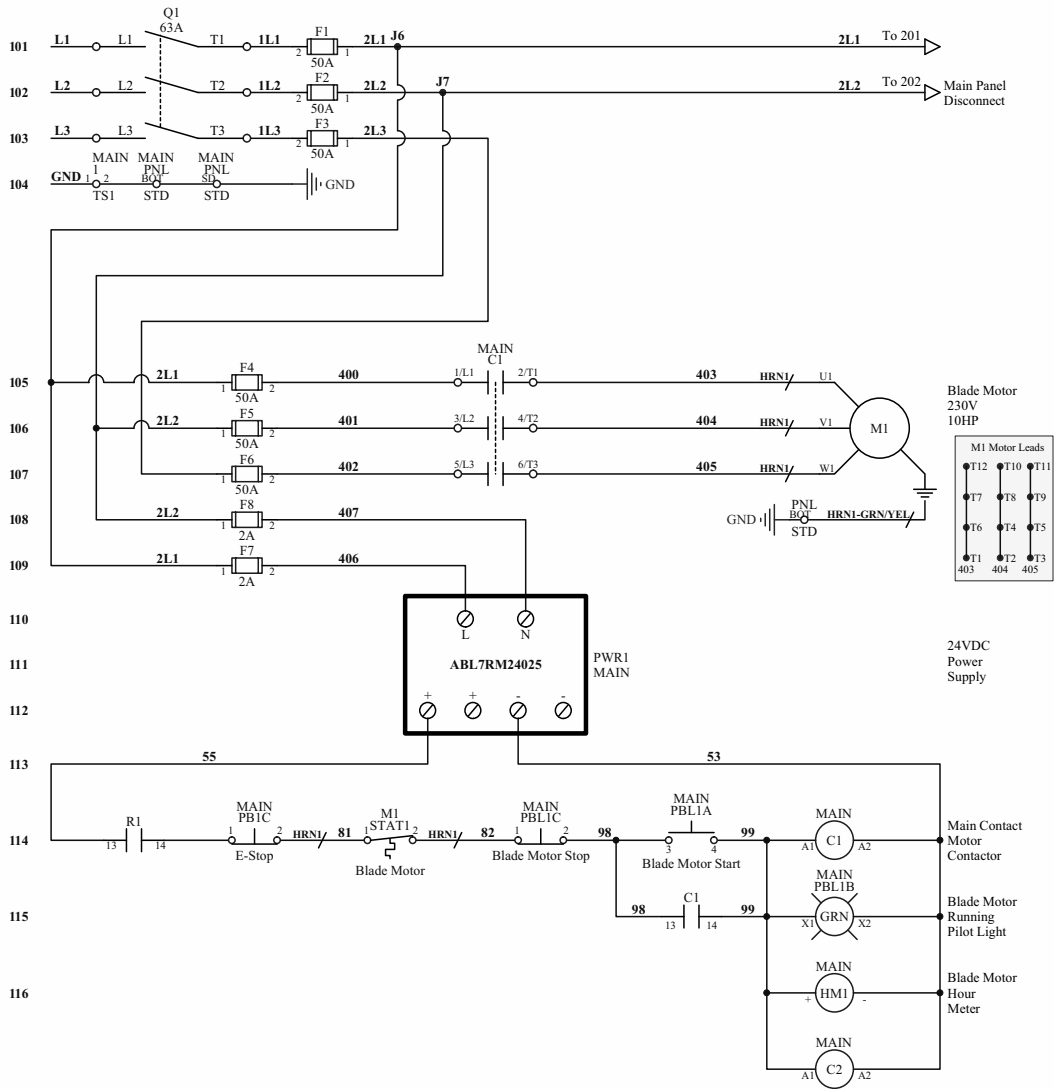

FIG. 4-3PAGE 1 OF 2



**FIG. 4-4PAGE 2 OF 2**

4.5 Wiring Diagram (LT15E10L)  
LT15E10L Rev. A.03+



# 4 Electrical Information

## Wiring Diagram (LT15E10L)

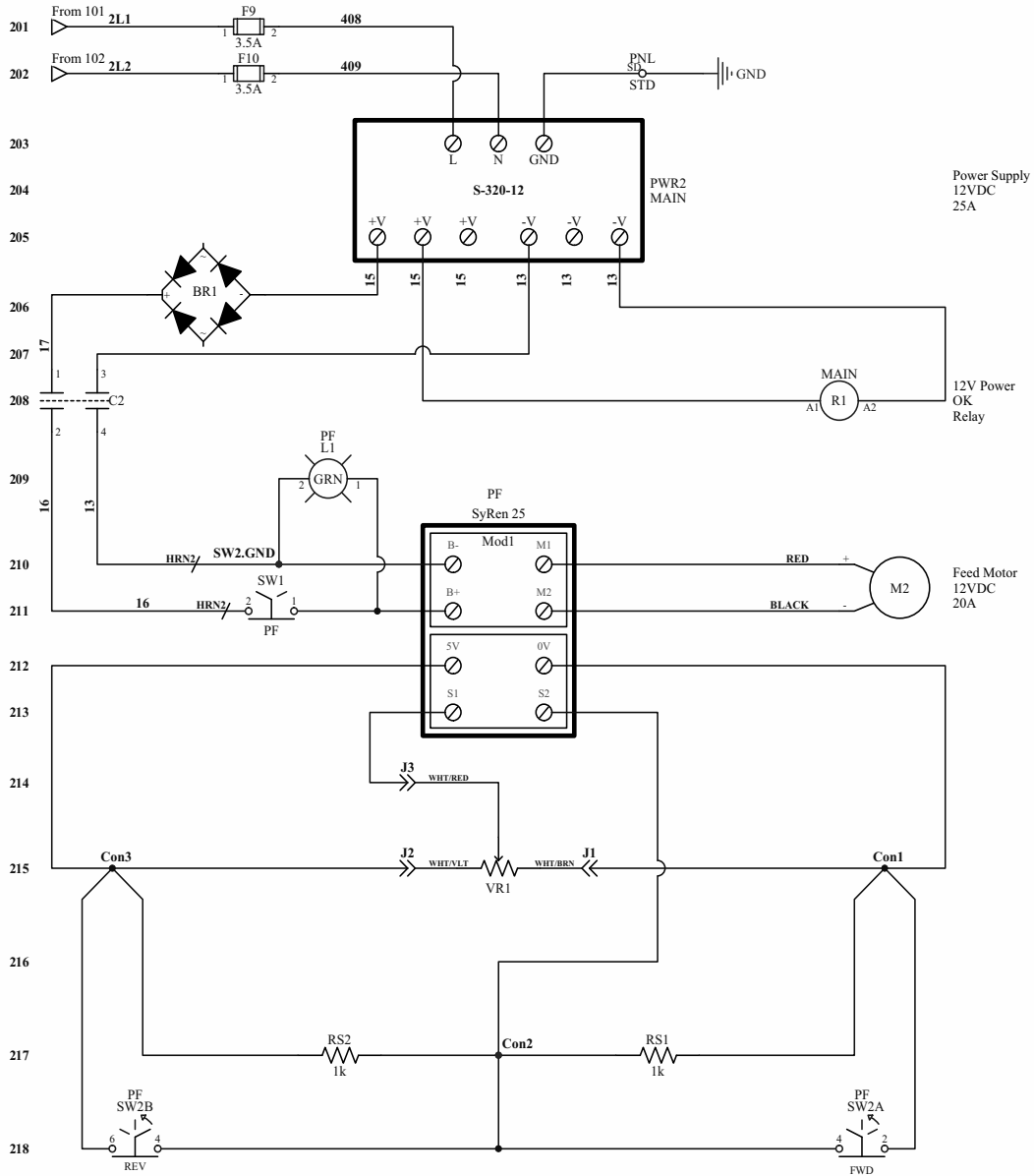

SW2

Position	Contacts					
	1	2	3	4	5	6
FWD	A	A	B	A	B	
N						
REV	A		A	B		B

4.6 Wiring Diagram (LT15E10L)  
LT15E10L Rev. A.00 - A.02

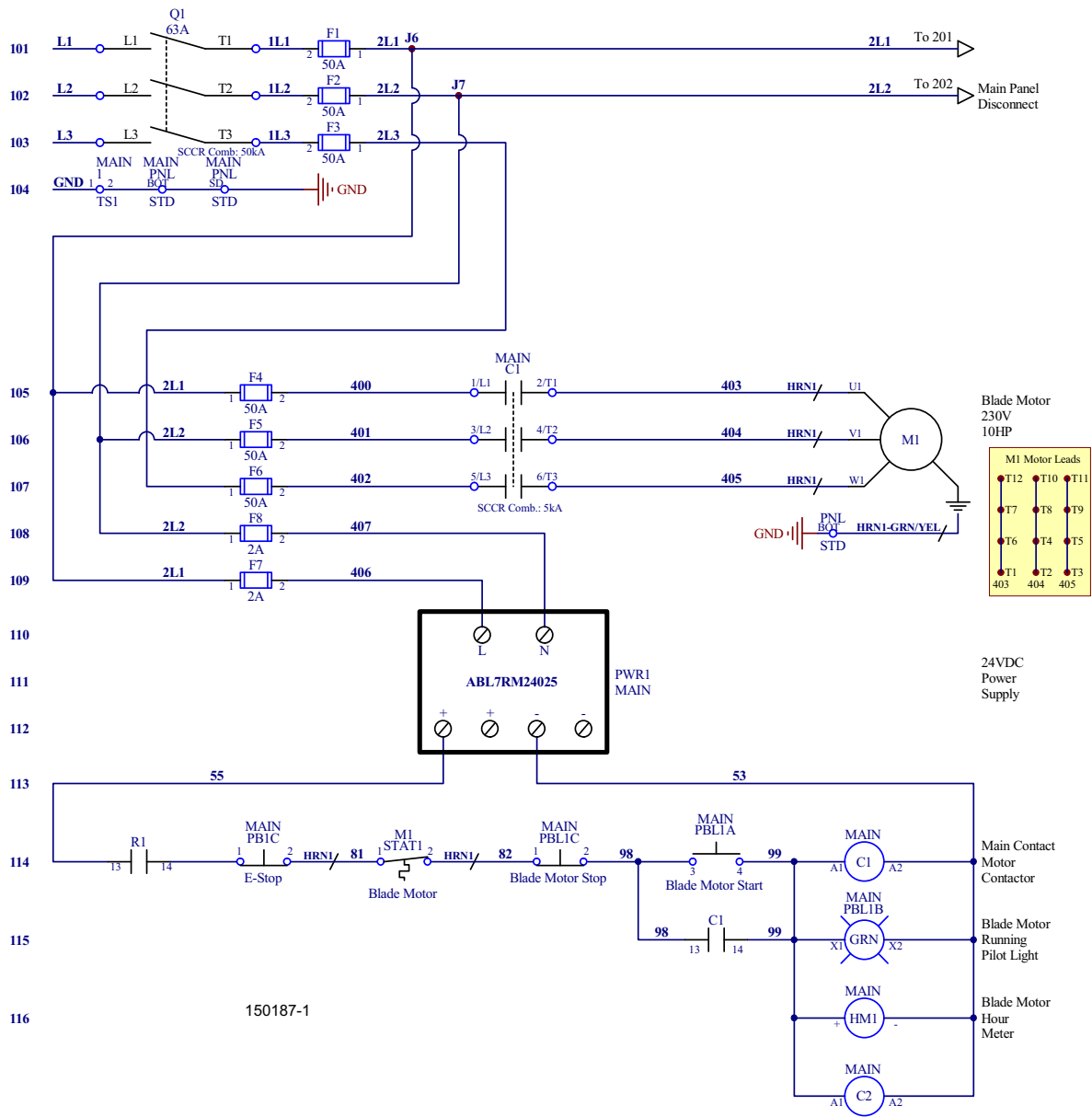
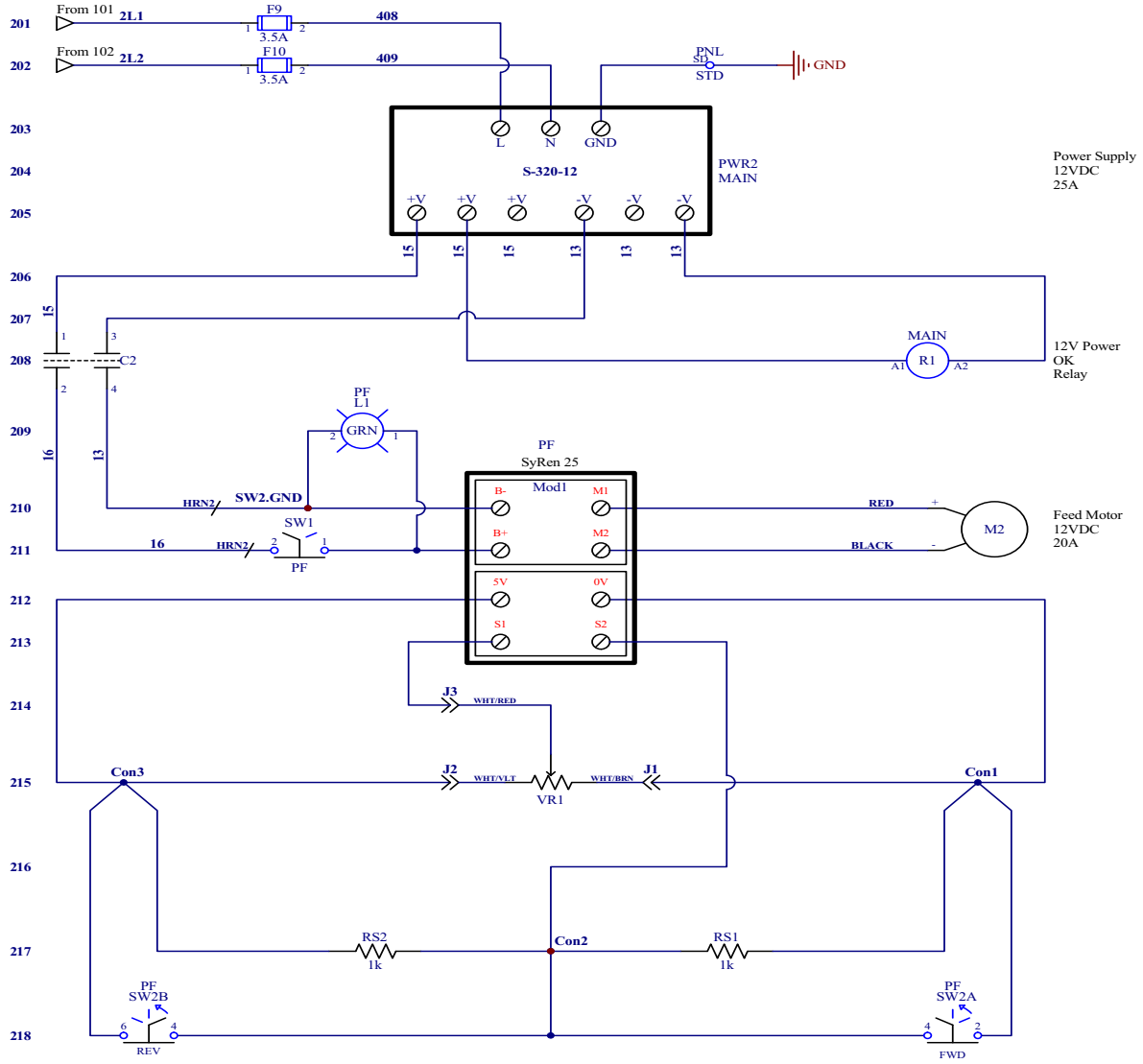

FIG. 4-5PAGE 1 OF 2

# 4 Electrical Information

## Wiring Diagram (LT15E10L)



Position	SW2 Contacts					
	1	2	3	4	5	6
FWD	A	A	B	A	B	
N						
REV	A		A	B	B	

150187-2

FIG. 4-6PAGE 2 OF 2

### 4.7 Wiring Diagram (LT15E10H) LT15E10H Rev. A.03+

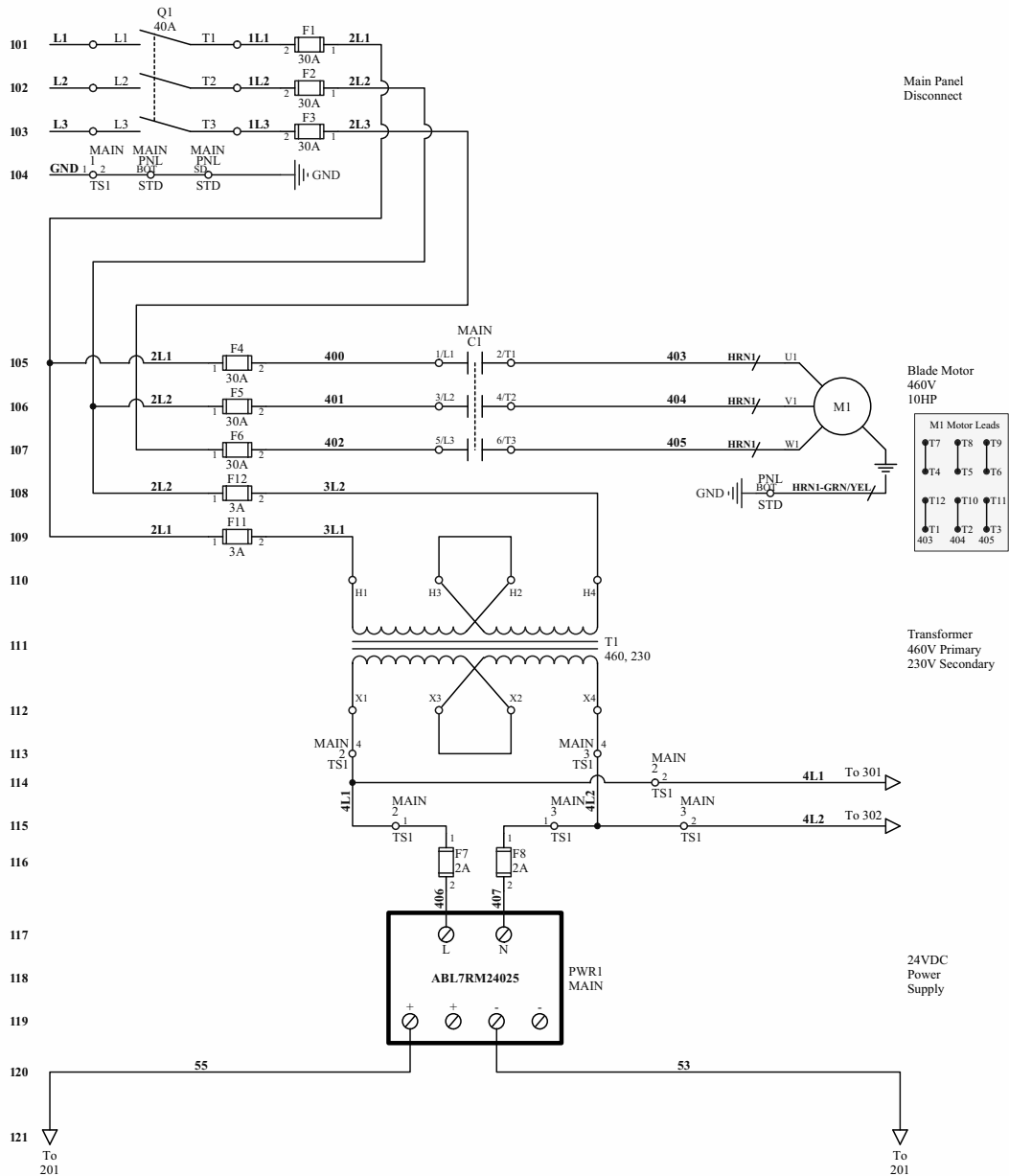

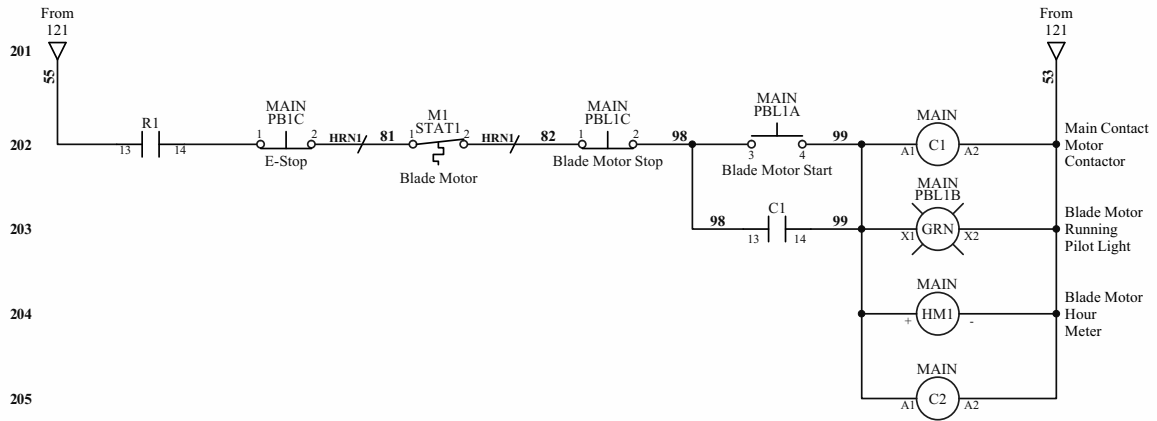



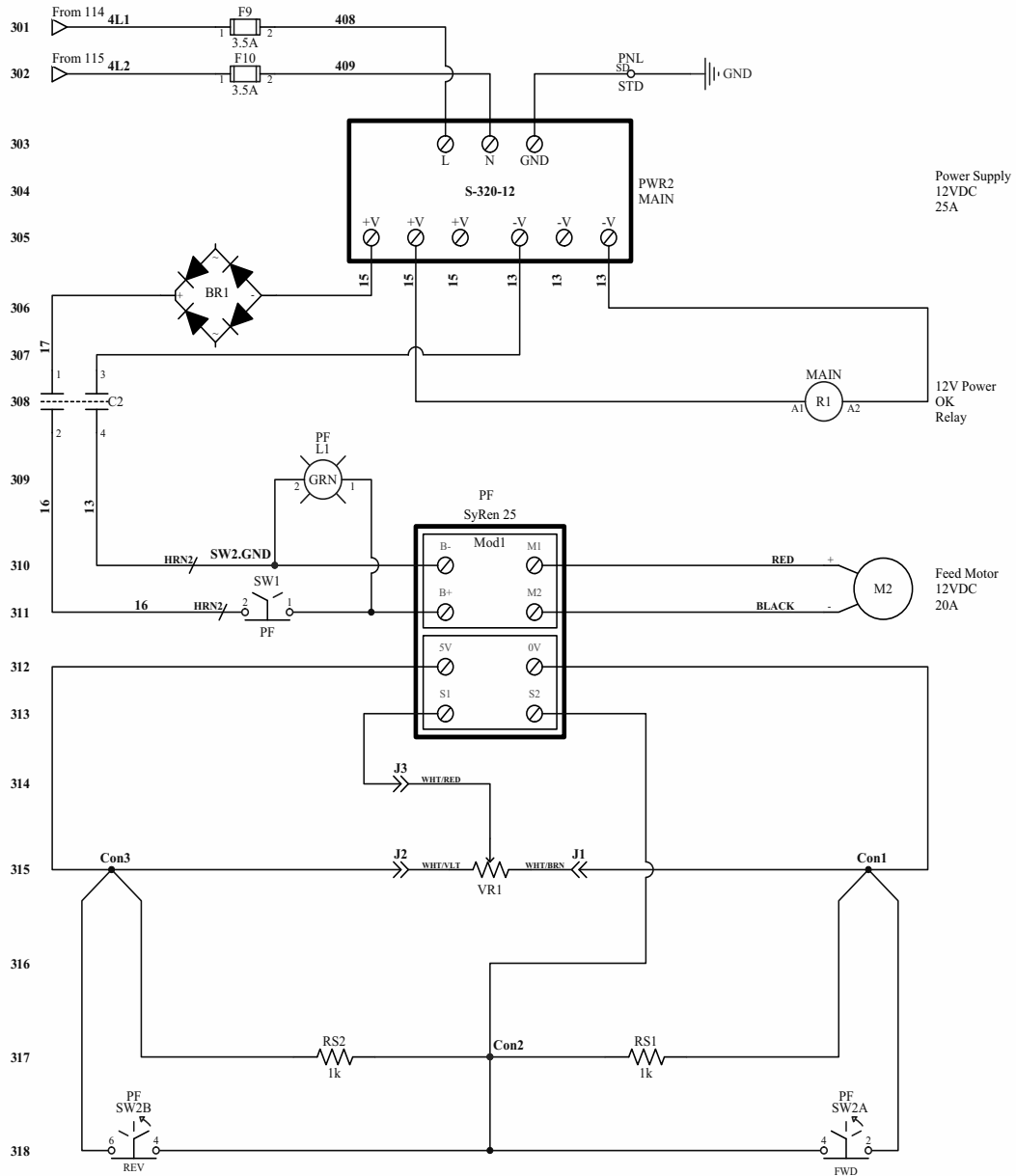

Position	Contacts					
	1	2	3	4	5	6
FWD	A	A	B	A	B	
N						
REV	A	A	B	B		

**4.8** Wiring Diagram (LT15E10H)  
LT15E10H Rev. A.00 - A.02

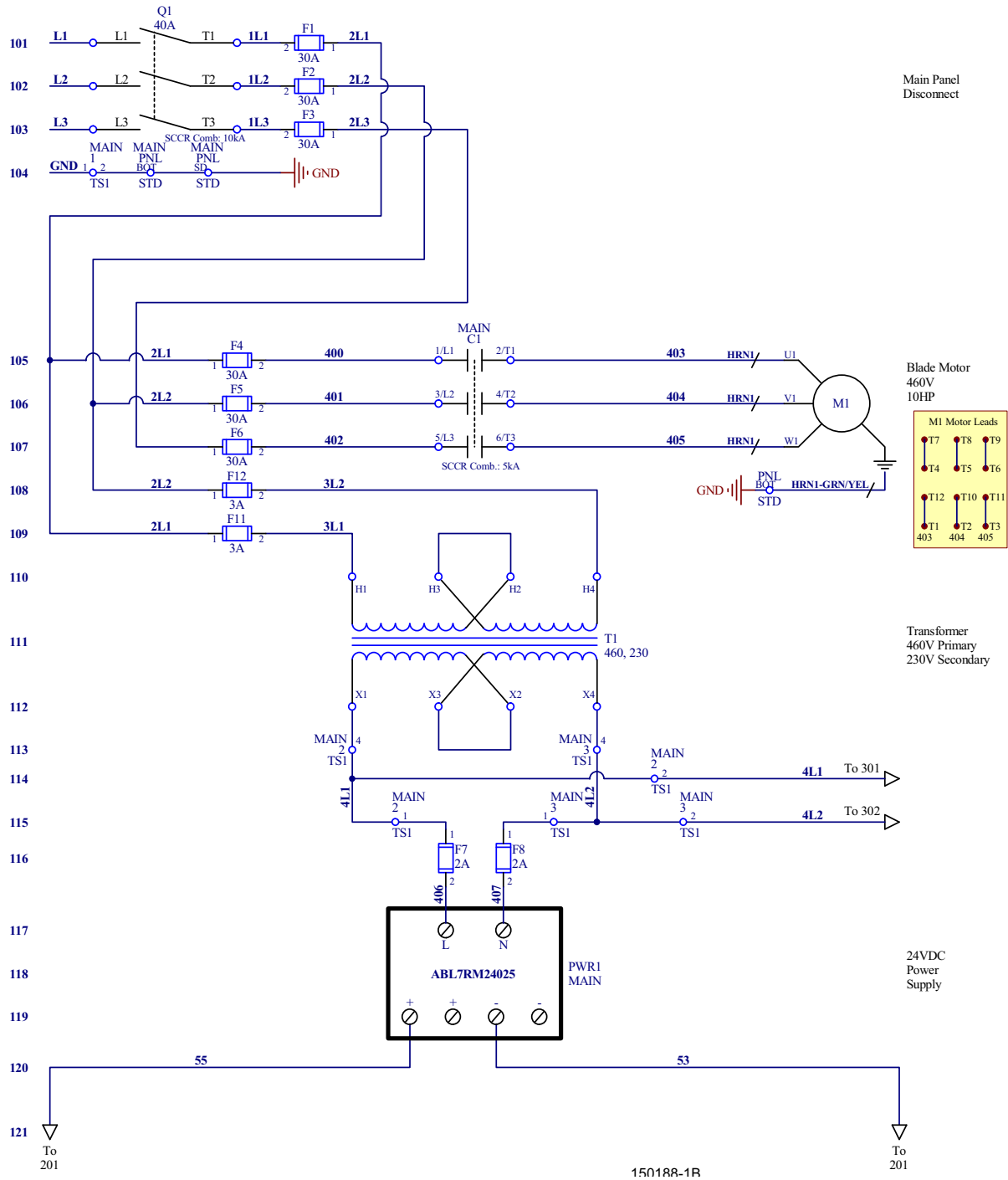

**FIG. 4-7PAGE 1 OF 3**

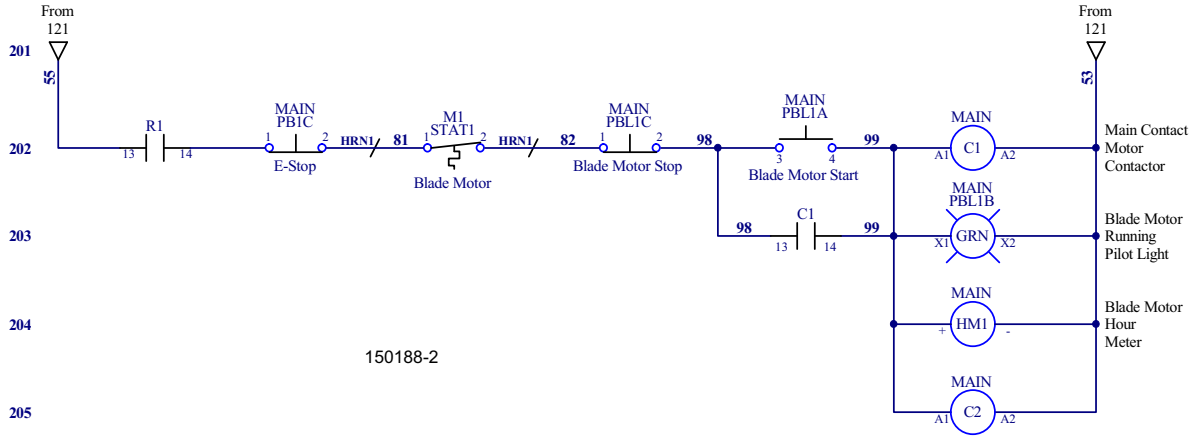
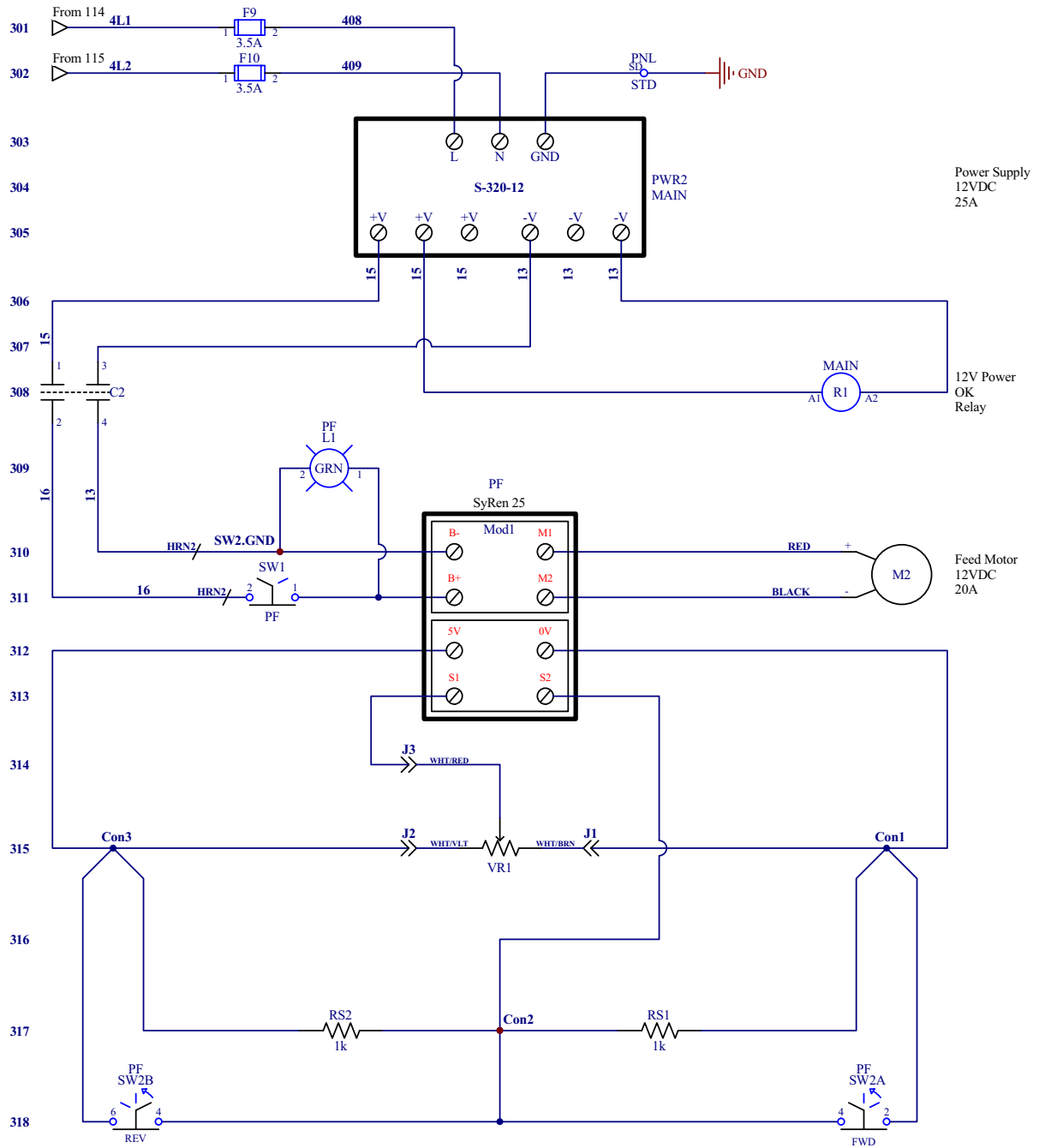

FIG. 4-8PAGE 2 OF 3

# 4 Electrical Information

## Wiring Diagram (LT15E10H)



SW2

Position	Contacts					
	1	2	3	4	5	6
FWD	A	A	B	A	B	
N						
REV	A		A	B		B

150188-3

FIG. 4-9PAGE 3 OF 3

## 4.9 Electrical Components (LT15PF)

LT15PF Rev. B.00+  
LT15PFE10SPF Rev. C.00+  
LT15LHPF Rev. B.00+

Component List				
Item	Mfg. Part No.	Mfg.	Wood-Mizer Part No.	Description
F1	FH-ATO-10-BR	Terminal Supply Co.	052164	Fuseholder, ATO 12AWG Radial Lead
	ATO 040	Littlefuse	024150-40	Fuse, 40A ATO Orange Blade
L1	1090QC5N1W12VIDI	IDI	E20483	Light, Green 12V .187 Tabs
M1	K01134F300	Klauber	133256	Gearmotor, Klauber 1/5HP 87RPM 12VDC
PCB1	073547	Wood-Mizer	073547	Control Module, Power Feed with Heatsink
SW1	55014	Cole Hersee	053695	Switch, SPST 25A Toggle
SW2	2601-AF2-S11	Square D	E20439	Switch, Power Feed Drum
VR1	024450-1	Wood-Mizer	024450-1	Potentiometer, Variable Resistance Power Feed

## 4.10 Electrical Components (LT15PF)

LT15PF Prior to Rev. B.00  
LT15PFE10SPF Prior to Rev. C.00  
LT15LHPF Prior to Rev. B.00

Component List				
Item	Mfg. Part No.	Mfg.	Wood-Mizer Part No.	Description
BR1	---	---	E10456	Rectifier, 200 PIV 35A Bridge
CON1-3	222-415	Wago	052293-5	Junction Block, 5-Position Wire Clamp
F1	FH-ATO-10-BR	Terminal Supply Co.	052164	Fuseholder, ATO 12AWG Radial Lead
	ATO 040	Littlefuse	024150-40	Fuse, 40A ATO Orange Blade
L1	1090QC5N1W12VIDI	IDI	E20483	Light, Green 12V .187 Tabs
M1	K01134F300	Klauber	133256	Gearmotor, Klauber 1/5HP 87RPM 12VDC
MOD1	057829-FR	Wood-Mizer	057829-FR <sup>1</sup>	Driver Kit, 25A DC Motor Field Replacement
RS1-2	053200	Wood-Mizer	053200	Resistor Assembly, 1K w 6" Yellow Wires
SW1	55014	Cole Hersee	053695	Switch, SPST 25A Toggle
SW2	2601-AF2-S11	Square D	E20439	Switch, Power Feed Drum
VR1	024450-1	Wood-Mizer	024450-1	Potentiometer, Variable Resistance Power Feed

<sup>1</sup> Field Replacement Kit 057829-FR replaces Driver Module 057829 originally supplied prior to 1/10. Module B-, B+, M1 & M2 connections changed from terminal block to spade terminal to allow proper wiring size to be used. Kit includes new driver module w/spade terminals, quick connect terminals and instructions.

## 4.11 Electrical Components (LT15E10SPF)

Component List				
Item	Mfg. Part No.	Mfg.	Wood-Mizer Part No.	Description
BR1	---	---	E10456	Rectifier, 200 PIV 35A Bridge
F7 - F8	LPSC002ID	Richards Electric	052512	Fuseholder, 2P Class CC 30A DIN Mount
	CCMR03.5	Richards Electric	052721	Fuse, 3.5A 600V Class CC Delay
HARN1	053708	Wood-Mizer	053708	Harness Assembly, LT15E10S Power Feed
L1	1090QC5N1W12VIDI	IDI	E20483	Light, Green 12V .187 Tabs
M1	K01134F300	Klauber	133256	Gearmotor, Klauber 1/5HP 87RPM 12VDC

Component List				
Item	Mfg. Part No.	Mfg.	Wood-Mizer Part No.	Description
<b>MOD1</b>	057829-FR	Wood-Mizer	057829-FR	Driver Kit, 25A DC Motor Field Replacement
<b>PWR2</b>	S-320-12	Mean Well	053592	Power Supply, 12VDC 320W
<b>R1</b>	CA3SK20JD	Schneider Electric	053590	Relay, Control 12VDC 2NO
<b>RS1-2</b>	053200	Wood-Mizer	053200	Resistor Assembly, 1K w 6" Yellow Wires
<b>SW1</b>	55014	Cole Hersee	053695	Switch, SPST 25A Toggle
<b>SW2</b>	2601-AF2-S11	Square D	E20439	Switch, Power Feed Drum
<b>TB2-1</b>	WAGO-2002-1292	Standard Electric	068102	Terminal Block, 2Pos 1.5mm End Plate
<b>VR1</b>	024450-1	Wood-Mizer	024450-1	Potentiometer, Variable Resistance Power Feed

#### 4.12 Electrical Components (LT15E10LHPF)

Component List				
Item	Mfg. Part No.	Mfg.	Wood-Mizer Part No.	Description
<b>BR1</b>	---	---	E10456	Rectifier, 200 PIV 35A Bridge
<b>C2</b>	LC1D32BD	Schneider Electric	052465	Contact, 32A 3P 24VDC Coil
<b>F7 - F8</b>	LPSC002ID	Richards Electric	052512	Fuseholder, 2P Class CC 30A DIN Mount
	CCMR03.5	Richards Electric	052721	Fuse, 3.5A 600V Class CC Delay
<b>HARN1</b>	053708	Wood-Mizer	053708	Harness Assembly, LT15E10S Power Feed
<b>L1</b>	1090QC5N1W12VIDI	IDI	E20483	Light, Green 12V .187 Tabs
<b>M1</b>	K01134F300	Klauber	133256	Gearmotor, Klauber 1/5HP 87RPM 12VDC
<b>MOD1</b>	057829-FR	Wood-Mizer	057829-FR	Driver Kit, 25A DC Motor Field Replacement
<b>PWR2</b>	S-320-12	Mean Well	053592	Power Supply, 12VDC 320W
<b>R1</b>	CA3SK20JD	Schneider Electric	053590	Relay, Control 12VDC 2NO
<b>RS1-2</b>	053200	Wood-Mizer	053200	Resistor Assembly, 1K w 6" Yellow Wires
<b>SW1</b>	55014	Cole Hersee	053695	Switch, SPST 25A Toggle
<b>SW2</b>	2601-AF2-S11	Square D	E20439	Switch, Power Feed Drum
<b>TB2-1</b>	WAGO-2002-1292	Standard Electric	068102	Terminal Block, 2Pos 1.5mm End Plate
<b>VR1</b>	024450-1	Wood-Mizer	024450-1	Potentiometer, Variable Resistance Power Feed

#### 4.13 Motor Driver Module DIP Switch Settings

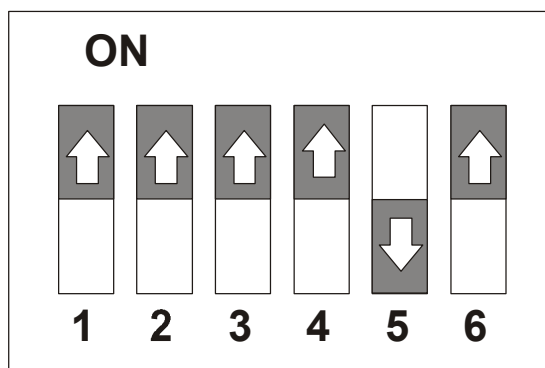

150177

**FIG. 4-10**