

LubeMizer (non-Remote) Option

Safety, Installation,
Operation, & Parts Manuals

LMS-LX (Installed LX450 NR)	rev. A.00
LMS-HP (Installed Non-Remote)	rev. E.00
LMS-A (Boxed Non-Remote)	rev. E.00

Safety is our #1 concern!

Form #885

Used with:

LT30
LT40
LT30HD
LT40HD
LT30 Super
LT40 Super
LT30HD Super
LT40HD Super
LX450



WARNING! Read and understand this manual before using this machine.

California

Proposition 65 Warning



WARNING: Breathing gas/diesel engine exhaust exposes you to chemicals known to the State of California to cause cancer and birth defects or other reproductive harm.

Always start and operate the engine in a well-ventilated area.
If in an enclosed area, vent the exhaust to the outside.
Do not modify or tamper with the exhaust system.
Do not idle the engine except as necessary.

For more information go to www.P65warnings.ca.gov.



WARNING: Drilling, sawing, sanding or machining wood products can expose you to wood dust, a substance known to the State of California to cause cancer. Avoid inhaling wood dust or use a dust mask or other safeguards for personal protection.

For more information go to www.P65Warnings.ca.gov/wood.

Active Patents assigned to Wood-Mizer, LLC

Wood-Mizer, LLC has received patents that protect our inventions which are a result of a dedication to research, innovation, development, and design. Learn more at: woodmizer.com/patents

©2024 Wood-Mizer LLC

Printed in the United States of America, all rights reserved. No part of this manual may be reproduced in any form by any photographic, electronic, mechanical or other means or used in any information storage and retrieval system without written permission from

Wood-Mizer, LLC
8180 West 10th Street
Indianapolis, Indiana 46214

SECTION 1 LUBEMIZER INSTALLATION

1.1 Control Box Installation..... 1-1

1.2 Control Box Wiring 1-2
LT30 Super Rev. G9.00+
LT40 Super Rev. H1.00+
LT30HD/40HD SuperRev. H4.00+
LX450 Rev. A1.00+ 1-2

1.3 Control Box Wiring 1-3
LT30 Super Rev. F7.00 - G8.00
LT40 Super Rev. F8.00 - G9.00
LT30HD/40HD SuperRev. G1.00 - H3.00 1-3

1.4 Control Box Wiring 1-4
LT30 Rev. F7.00+
LT40 Rev. F8.00+
LT30HD/40HDRev. G1.00+ 1-4

1.5 Bottle Conversion and Hose Installation (LT30/LT40 Sawmills)..... 1-6

1.6 Hose Line Installation (LX450 Sawmills) 1-7

1.7 Finishing Steps..... 1-7

SECTION 2 OPERATION

2.1 The LubeMizer System..... 2-1

2.2 Lube Additives..... 2-1

SECTION 3 MAINTENANCE

SECTION 4 REPLACEMENT PARTS

4.1 Pump Assembly (LMS-HP/LMS-A) 4-1

4.2 Pump Assembly (LMS-LX)..... 4-3

4.3 Filter Assembly (LMS-HP/LMS-A) 4-4

4.4 Filter Assembly (LMS-LX) 4-5

4.5 Blade Guide Block Assembly (LMS-A Only) 4-6

4.6 Control Box Assembly 4-7

SECTION 5 ELECTRICAL INFORMATION

5.1 Electrical Components 5-1

5.2 Electrical Wiring Diagram (Control Circuit)..... 5-2

5.3 Electrical Symbol Diagram..... 5-3

SECTION 1 LUBEMIZER INSTALLATION

1.1 Control Box Installation

1. Raise the saw head to access the battery box. Turn the key to the OFF (#0) position and remove the key.
2. Remove the two wing nuts and flat washers holding the battery box lid to the battery box.
3. Lift and remove the battery box lid.
4. Remove the negative (-) battery post terminal clamp.
5. Remove the rear panel assembly from the control box.
6. Remove the left control box side panel from the sawmill control box. **See Fig. 1-1.**
7. Remove the two solenoids from the panel assembly and install them to the provided lube control assembly.
8. Check to ensure that wires are not kinked or pinched.

After wiring, the lube control assembly will be secured in place.

WIRING INSTALLATION.

Refer to the table below for your model mill and the applicable wire installation section.

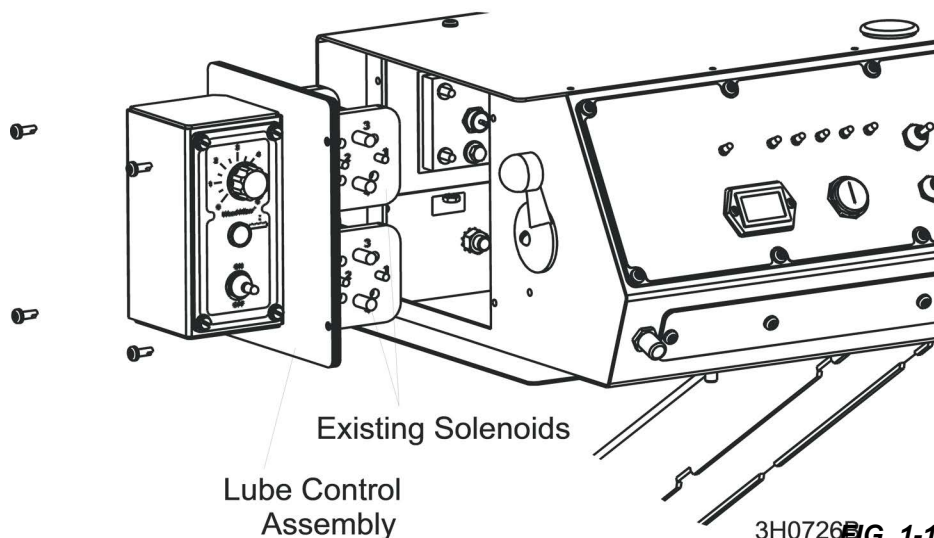

3H0726 **FIG. 1-1**

Mill Model	Revision	Wiring Instructions Section
LT30	F7.00+	See Section 1.4
LT40	F8.00+	See Section 1.4
LT30HD/40HD	G1.00+	See Section 1.4
LT30 Super	G9.00+	See Section 1.2
	F7.00 - G8.00	See Section 1.3
LT40 Super	H1.00+	See Section 1.2
	F8.00 - G9.00	See Section 1.3
LT30HD/40HD Super	H4.00+	See Section 1.2
	G1.00 - H3.00	See Section 1.3
LX450	A1.00+	See Section 1.2

TABLE 1-1

1.2 Control Box Wiring

LT30 SuperRev. G9.00+
LT40 SuperRev. H1.00+
LT30HD/40HD SuperRev. H4.00+
LX450Rev. A1.00+



DANGER! The key switch should still be off, the key removed and the negative battery cable disconnected as stated at the beginning of this section. The incoming power supply of electric-powered sawmills should be disconnected and locked out. Failure to do so will result in serious injury or death.

NOTICE Avoid pinch and pivot points, unnecessary wire bending and open spaces where the wire could get caught by a log, etc. If you have any questions, call Wood-Mizer customer service.

Refer to the appropriate wiring diagram while performing the wiring steps below.

1. Locate red wire #19 inside the sawmill control box.
2. Disconnect wire #19 from the red jumper wire connected to the feed drum switch (or terminal #T13 of the wireless interface on wireless sawmills).
3. Connect red lube wire #251 to red wire #19. Connect red lube wire #250 to the red jumper wire.
4. Locate black wire #20 inside the sawmill control box.
5. Disconnect wire #20 from the black jumper wire connected to the ground stud at the back of the control box.
6. Connect blue lube wire #257 to black wire #20. Connect black lube wire #259 to the black ground jumper wire.
7. Using the existing mounting bolts, install the lube control assembly to the sawmill control box.
8. Replace the rear control box panel.



STOP! You have completed Control Box Wiring. Proceed to Section 1.5 Pump Installation And Wiring (All LT30/LT40 Sawmills) or Section 1.6 Pump Installation And Wiring (LX450 Sawmills).

1.3 Control Box Wiring

LT30 SuperRev. F7.00 - G8.00
LT40 SuperRev. F8.00 - G9.00
LT30HD/40HD SuperRev. G1.00 - H3.00



DANGER! The key switch should still be off, the key removed and the negative battery cable disconnected as stated at the beginning of this section. The incoming power supply of electric-powered sawmills should be disconnected and locked out. Failure to do so will result in serious injury or death.

NOTICE Avoid pinch and pivot points, unnecessary wire bending and open spaces where the wire could get caught by a log, etc. If you have any questions, call Wood-Mizer customer service.

Refer to the appropriate wiring diagram while performing the wiring steps below.

1. Locate red wire #19 connected to terminal #2 of the power feed drum switch.
2. Cut wire #19 approximately 5" from terminal #2.
3. Install a female terminal to the end of the 5" length of wire #19 that remains connected to terminal #2.
4. Install a male terminal to the end of the remaining length of wire #19.
5. Connect red lube wire #250 to the female terminal on the 5" length of wire #19.
6. Connect red lube wire #251 to the male terminal on the remaining length of wire #19.
7. Locate black wire #20 connected to the ground stud at the rear of the sawmill control box.
8. Cut wire #20 approximately 5" from the ground stud.
9. Install a female terminal to the end of the 5" length of wire #20 that remains connected to the ground stud.
10. Install a male terminal to the end of the remaining length of wire #20.
11. Connect black lube wire #259 to the female terminal to the female terminal on the 5" length of wire #20.
12. Connect blue lube wire #257 to the male terminal on the remaining length of wire #20.
13. Using the existing mounting bolts, install the lube control assembly to the sawmill control box.
14. Replace the rear control box panel.

Male Terminal

Female Terminal

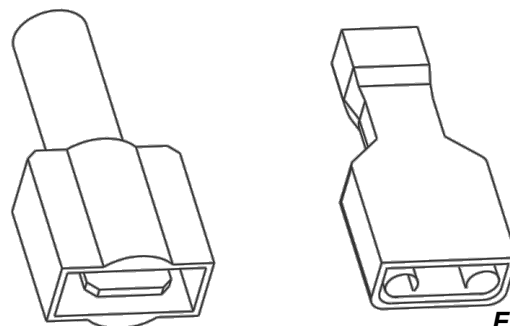

FIG. 1-2



STOP! You have completed Control Box Wiring. Proceed to Section 1.5 Pump Installation And Wiring (All LT30/LT40 Sawmills).

1.4 Control Box Wiring

LT30Rev. F7.00+
LT40Rev. F8.00+
LT30HD/40HDRev. G1.00+



DANGER! The key switch should still be off, the key removed and the negative battery cable disconnected as stated at the beginning of this section. The incoming power supply of electric-powered sawmills should be disconnected and locked out. Failure to do so will result in serious injury or death.

NOTICE Avoid pinch and pivot points, unnecessary wire bending and open spaces where the wire could get caught by a log, etc. If you have any questions, call Wood-Mizer customer service.

Refer to the appropriate wiring diagram while performing the wiring steps below.

1. Locate red wire #19 lying loose in the sawmill control box.

NOTE: Install a male connector to the end of wire #19 if one is not already supplied.

2. Connect red lube wire #251 to red wire #19.

NOTE: If you have installed a water lube solenoid kit (#016141) there will be a fuseholder assembly between wire #19 and the #2 drum switch terminal.

3. Unplug the fuse holder assembly from wire #19 and plug red lube wire #251 in its place.
4. Leave the assembly wire connected to the #2 drum switch terminal, but cut the wire 5" from the terminal.
5. Install a female terminal to the end and connect red lube wire #250 to the female terminal. **See Fig. 1-4.**
 - a. Install the supplied 6" red wire to the #2 terminal of the power feed drum switch.

NOTE: If your sawmill is equipped with a debarker option, disconnect the red debarker on/off switch wire from the #2 power feed drum switch terminal.

- b. Use the supplied #10-24 x 1/2" screw, flat washer and lock nut to connect wire #250 from the LMS control to the 6" wire from the #2 power feed drum switch terminal (and debarker wire, if applicable).
- c. Place the supplied rubber tube over the wire connection, fold and secure with the two wire ties supplied. **See Fig. 1-3.**
- d. Locate black wire #20 connected to the ground stud in the rear of the sawmill control.
- e. Cut the wire in two approximately 5" from the ground stud.
- f. Install a female terminal to the end of the 5" length of wire #20 that remains connected to the ground stud.

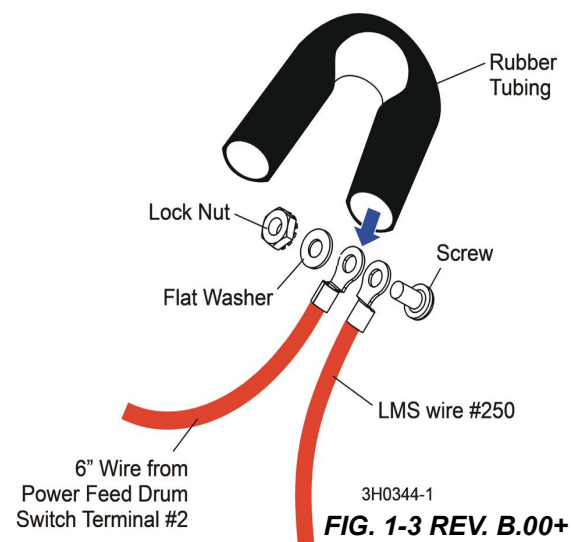

1.5 Bottle Conversion and Hose Installation (LT30/LT40 Sawmills)

1. Reinstall the bottle to the mill.
2. Reinstall the fuel bottle. If necessary, resecure the fuel line hose clamps.
3. Remove the entire blade guide roller and block assembly from the sawmill.
4. **Sawmills equipped with Roller-Only blade guides:** Remove the roller from the block and install it to the provided lube blade guide block assembly.
5. Wrap the threads of the provided fittings, nozzles and plug with teflon tape (pipe tape) and install the components to the blade guide block as shown in FIG. 1-10. (An extra nozzle is provided for service replacement.)
6. **Sawmills equipped with Roller-Only blade guides:** Install the lube block assembly to the mill.
7. Orient the nozzles so that oil flow is directed on the blade.
8. Locate the provided 1/4" hose. Insert one end to the pump valve as shown in FIG. 1-5.
9. Route the hose through 1/2" hose clamp.
10. Continue routing through the grommet in the motor mount and connect the remaining end to the fitting on the block assembly.
11. Use wire ties to secure the hose near the motor mount and again at the block assembly as shown in FIG. 1-11.

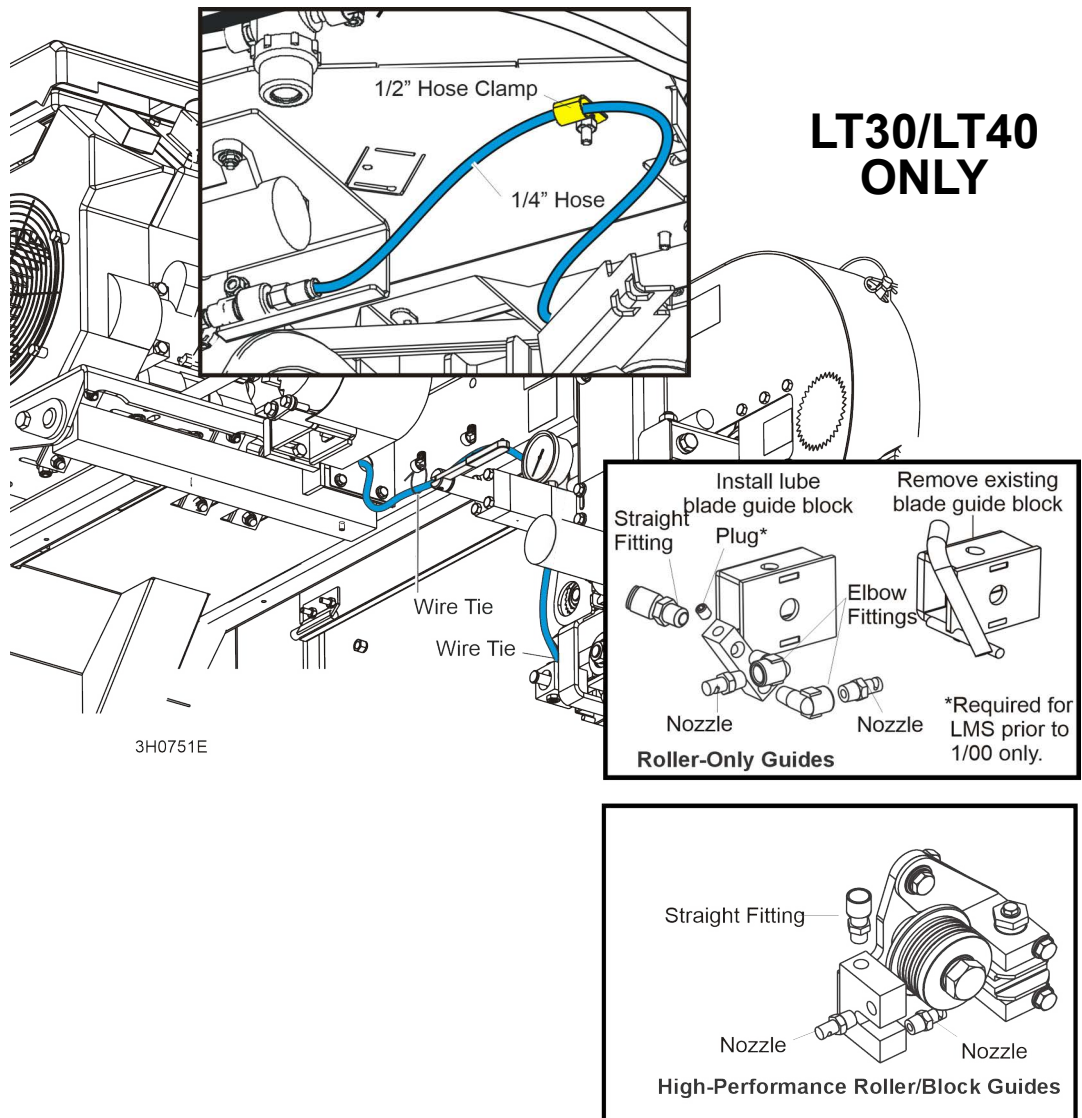

FIG. 1-5 REVISION A.01+

1.6 Hose Line Installation (LX450 Sawmills)

1. Reinstall the fuel tank; if necessary, resecure the fuel line hose clamps.
2. Locate the provided 1/4" hose.
3. Insert one end to the pump valve as shown in FIG. 1-6.
4. Route the hose and connect the remaining end to the fitting on the block assembly.

1.7 Finishing Steps



DANGER! Make sure all guards and covers are in place and secured before operating or towing the sawmill. Failure to do so may result in serious injury.

Be sure the blade housing and pulley covers are in place and secure. Use the safety retainer pin and cable to fasten blade housing covers.

1. **LT30/LT40 Only:** Reinstall the drive side blade housing cover and left pan cover.
2. Reconnect the negative battery terminal cable and replace the battery box cover.
3. Align the inner blade guide assembly as instructed in the alignment section of your Wood-Mizer Operator's Manual.

After blade guide alignment, be sure to check the scale indicator to make sure it is adjusted properly (procedure also found in the alignment section of your Wood-Mizer Operator's Manual).

4. Fill the water lube bottle with clean water.

Avoid using water that might contain foreign substances such as algae, dirt, or minerals that can damage the pump or clog the check valves.

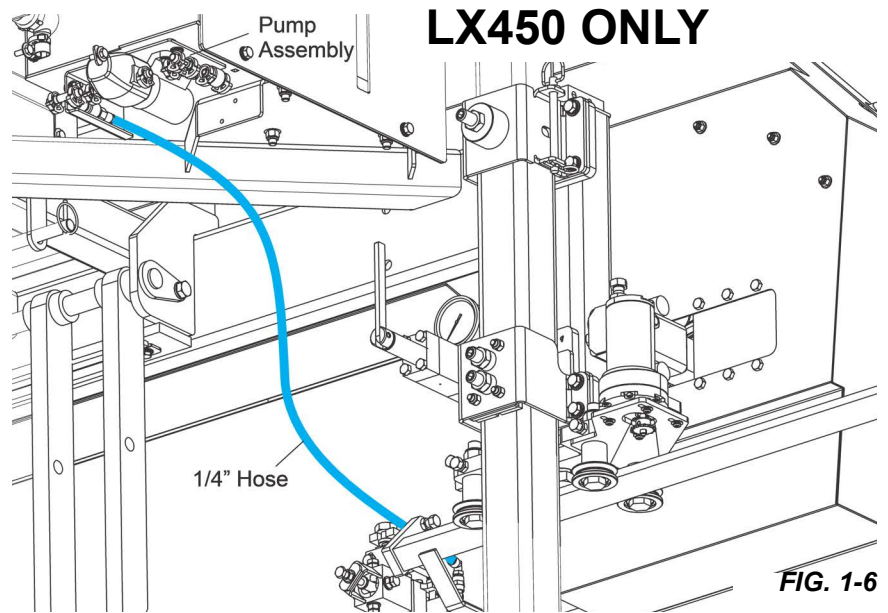

FIG. 1-6

SECTION 2 OPERATION

2.1 The LubeMizer System

The LubeMizer system utilizes an automatic valve to activate the lubricant flow only when the saw carriage is moving forward. The LubeMizer control box adjusts the volume of lubricant for various wood types. The LubeMizer option uses less lubricant, helping to reduce lubricant/sawdust mess and waste, and to prevent stained boards.

Usual flow will be between 0.07 and 2.5 gallons (2.6 - 9.5 liters) per hour.

START THE SELF-PRIMING SYSTEM

1. Open the water lube bottle valve all the way.
2. Turn the sawmill control box key to the ACC or ON position.
3. Turn the lube control switch to PULSE¹ and set the lube dial to the desired flow rate.
4. Use the lowest setting that successfully eliminates pitch buildup.

NOTE: Softwood applications will usually require more lubricant than hardwood applications.

5. Cut the log as normal.

SHUT OFF THE LUBE

1. Turn the lube control switch to OFF.
2. Close the lube bottle valve all the way.

NOTE: If you are sawing or storing the sawmill in freezing temperatures, use windshield washer fluid to help prevent the water from freezing ([See Section 2.2](#)).



CAUTION! Add windshield washer fluid to the water tank and prime as recommended when sawing or storing the sawmill in below-freezing temperatures. Use windshield washer fluid with a freezing point of at least -20°F (-29°C). Failure to do so will cause damage to the LubeMizer system may result.

2.2 Lube Additives

For further benefits, add 12oz. of Wood-Mizer Lube Additive to a 5 gallon jug of water. Wood-Mizer Lube Additive significantly reduces resin buildup on the blade. It helps to reduce heat buildup, wavy cuts, and blade noise. This biodegradable and environmentally friendly pre-mix includes a water softener additive for hard water.



WARNING! Use ONLY water, Wood-Mizer Lube Additive or windshield washer fluid with the water lube accessory. Never use flammable fuels or liquids such as diesel fuel. If these types of liquids are necessary to clean the blade, remove it and clean with a rag. Failure to do so can damage the equipment and may result in serious injury or death.

Use windshield washer fluid as an antifreeze to prevent the water from freezing and damaging the LubeMizer system. See the chart below for recommended mixture levels depending on the temperature where you are sawing or storing the sawmill.

Run the LubeMizer system on the "Continuous" setting for 30 seconds after adding the windshield washer fluid to the system. This will insure the water throughout the system will not freeze and damage the check valves.

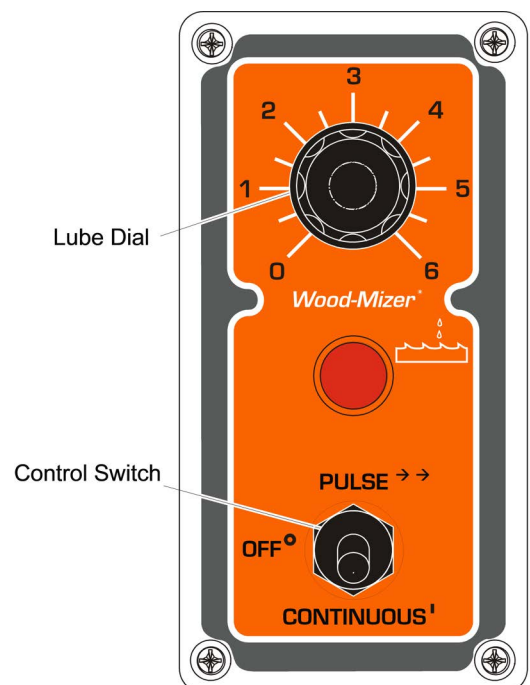

FIG. 2-1

¹. Pulse is suitable for most cutting applications. CONTINUOUS delivers a steady stream of lubricant and should be used only for heavy pitch buildup or occasional blade cleaning.



CAUTION! Add windshield washer fluid to the water tank and prime as recommended when sawing or storing the sawmill in below-freezing temperatures. Use windshield washer fluid with a freezing point of at least -20°F (-29°C). Failure to do so may cause damage to the LubeMizer system.

Ratio WWF:Water to fill 5 Gal. tank	Freezing Point Of Solution	
	(°F)	(°C)
5:0	-22	-30
4:1	-3	-19
3:2	7	-14
2.5:2.5	13	-10
1:4	24	-4
0:5	32	0

TABLE 2-1

SECTION 3 MAINTENANCE



DANGER! On electric mills, hazardous voltage inside the disconnect box, starter box, and at the electric motor can cause shock, burns, or death. Disconnect and lock out power supply before performing service! Follow all applicable electrical codes.

DANGER! Make sure all electrical installation, service and/or maintenance work is performed by a qualified electrician and is in accordance with applicable electrical codes. Failure to do so will result in serious injury or death.

DANGER! Before performing any service to this equipment, turn the key to the OFF position, remove the key, and disconnect the battery ground terminal. Failure to do so will result in serious injury or death.

CLEAN THE LUBE FILTER.

1. Make sure the lube control is in the OFF position and the lube bottle valve is closed all the way.
2. Unscrew the filter reservoir and flush with water.
3. Remove the cylindrical mesh filter and gently flush with water.

REPLACE THE FILTER AND RESERVOIR

1. Periodically check lube hoses and lines for buildup.
2. Remove and flush with water as needed.
3. Periodically check the blade guide bracket nozzles for buildup.
4. Remove and flush with water as needed.

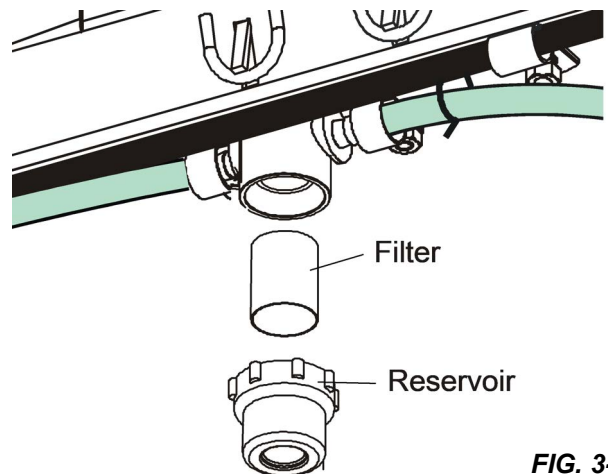
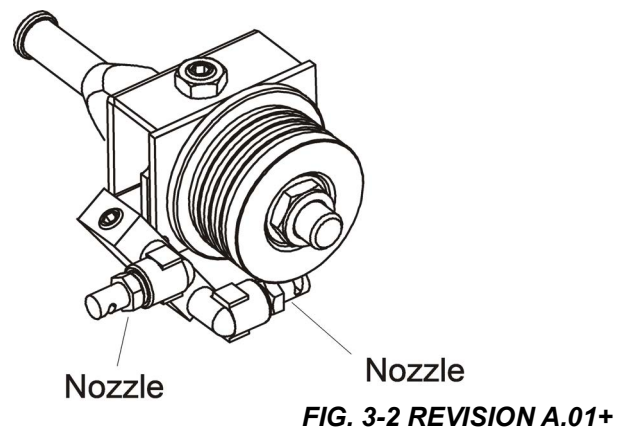
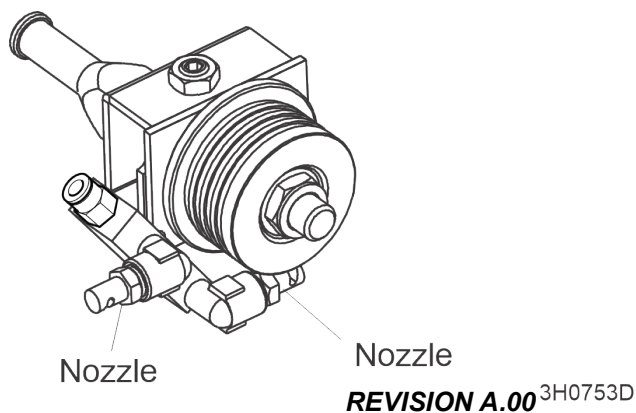
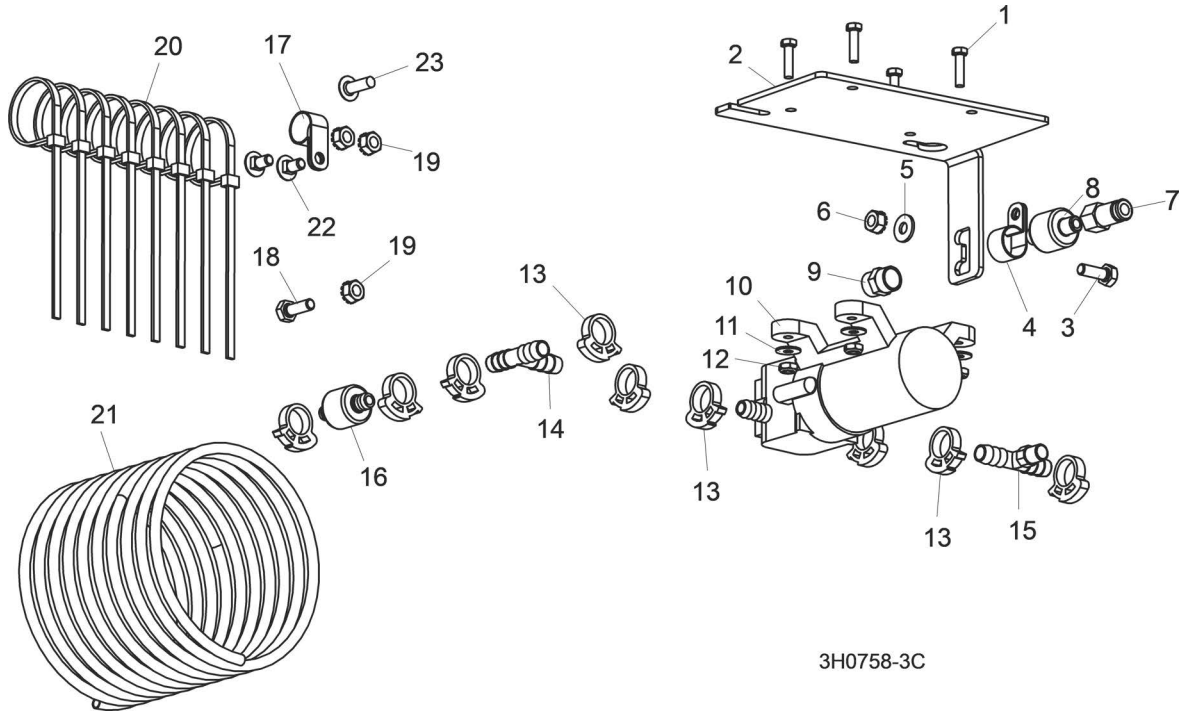

FIG. 3-1



SECTION 4 REPLACEMENT PARTS

4.1 Pump Assembly (LMS-HP/LMS-A)



REF	PART #	DESCRIPTION	COMMENTS	QTY.
1	F05004-167	BOLT, #10-24 X 3/4" UNSLOTTED HEX HEAD		4
2	130780	PLATE, PUMP MOUNTING		1
3	F05005-1	BOLT, 1/4-20 X 3/4" HEX HEAD FULL THREAD		1
4	010748	CLAMP, 1/2" EMT COATED		1
5	F05011-11	WASHER, 1/4" SAE FLAT		1
6	F05010-9	NUT, 1/4-20 SELF LOCKING		1
7	033450	FITTING, 1/4" TUBE X 1/8" NPT MALE AIR		1
8	033449	VALVE, 1/8" NPT 3PSI CHECK		1
9	P05748	FITTING, 1/8" FPT COUPLING		1
10	033492	PUMP ASSEMBLY, PRESSURE LUBE		1
	033442	Head Kit, Pressure Lube Pump		1
	024123	Diode Assembly, Inductive Kick Protection		1
	074750	Fitting, Pump 12VDC Feed		1
11	F05011-18	WASHER, #10 SAE FLAT		4
12	F05010-160	NUT, #10-24 HEX SELF LOCKING		4
13	016845	CLAMP, SINGLE SNAP GRIP #38		9
14	033451	FITTING, 3/8" BARB TEE CONNECTOR		1
15	033452	FITTING, 3/8" X 1/8" NPT MALE BRANCH TEE		1
16	033448	VALVE, 3/8" BARB 6 PSI CHECK		1
17	010748	CLAMP, 5/8" EMT COATED		1
18	F05005-1	SCREW, 1/4-20 X 3/4" FULL THREAD HEX HEAD CAP		1
19	F05010-9	NUT, 1/4-20 SELF LOCKING		1
20	F05089-3	TIE WRAP, 3/16 X 5 1/2" UV BLACK		7

REF	PART #	DESCRIPTION	COMMENTS	QTY.
21	033456	HOSE, 1/4" OD X 8.5'		1
22	F05005-33	BOLT, 1/4-20 X 1/2" CARRIAGE		2
23	F05005-138	SCREW, 1/4-20 X 3/4" PHILLIPS ROUND HEAD		1
	107942	HOSE, 1/4ODX50 (LX450 ONLY)		1
	F05005-113	BOLT, 1/4-20X3/4 CARRIAGE	(LX450 ONLY)	4

4.2 Pump Assembly (LMS-LX)

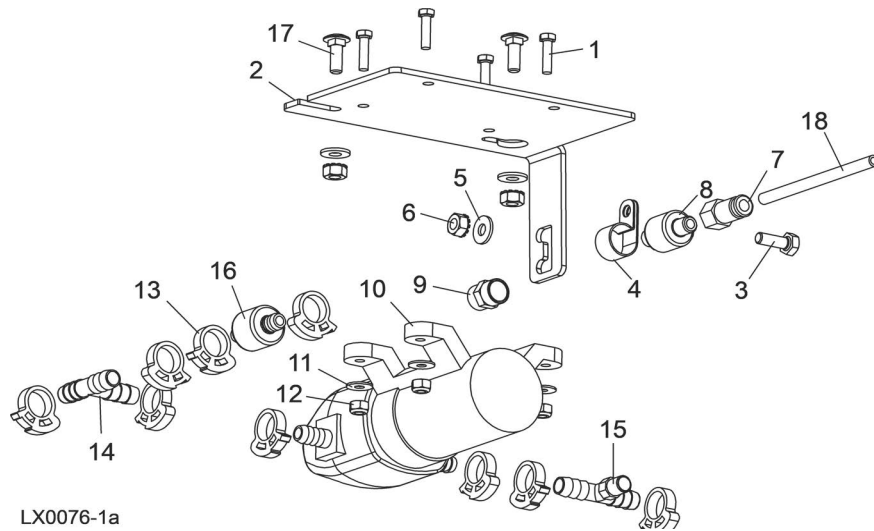

REF	PART #	DESCRIPTION	COMMENTS	QTY.
1	F05004-167	BOLT, #10-24 X 3/4" UNSLOTTED HEX HEAD		4
2	130780	PLATE, PUMP MOUNTING		1
3	F05005-1	BOLT, 1/4-20 X 3/4" HEX HEAD FULL THREAD		1
4	010748	CLAMP, 1/2" EMT COATED		1
5	F05011-11	WASHER, 1/4" SAE FLAT		3
6	F05010-9	NUT, 1/4-20 SELF LOCKING		3
7	033450	FITTING, 1/4" TUBE X 1/8" NPT MALE AIR		1
8	033449	VALVE, 1/8" NPT 3PSI CHECK		1
9	P05748	FITTING, 1/8" FPT COUPLING		1
10	033492	PUMP ASSEMBLY, PRESSURE LUBE		1
	033442	Head Kit, Pressure Lube Pump		1
	024123	Diode Assembly, Inductive Kick Protection		1
	074750	Fitting, Pump 12VDC Feed		1
11	F05011-18	WASHER, #10 SAE FLAT		4
12	F05010-160	NUT, #10-24 HEX SELF LOCKING		4
13	016845	CLAMP, SINGLE SNAP GRIP #38		9
14	033451	FITTING, 3/8" BARB TEE CONNECTOR		1
15	033452	FITTING, 3/8" X 1/8" NPT MALE BRANCH TEE		1
16	033448	VALVE, 3/8" BARB 6 PSI CHECK		1
17	F05005-113	BOLT, 1/4-20X3/4 CARRIAGE		4
18	107942	HOSE, 1/4ODX50		1

4.3 Filter Assembly (LMS-HP/LMS-A)

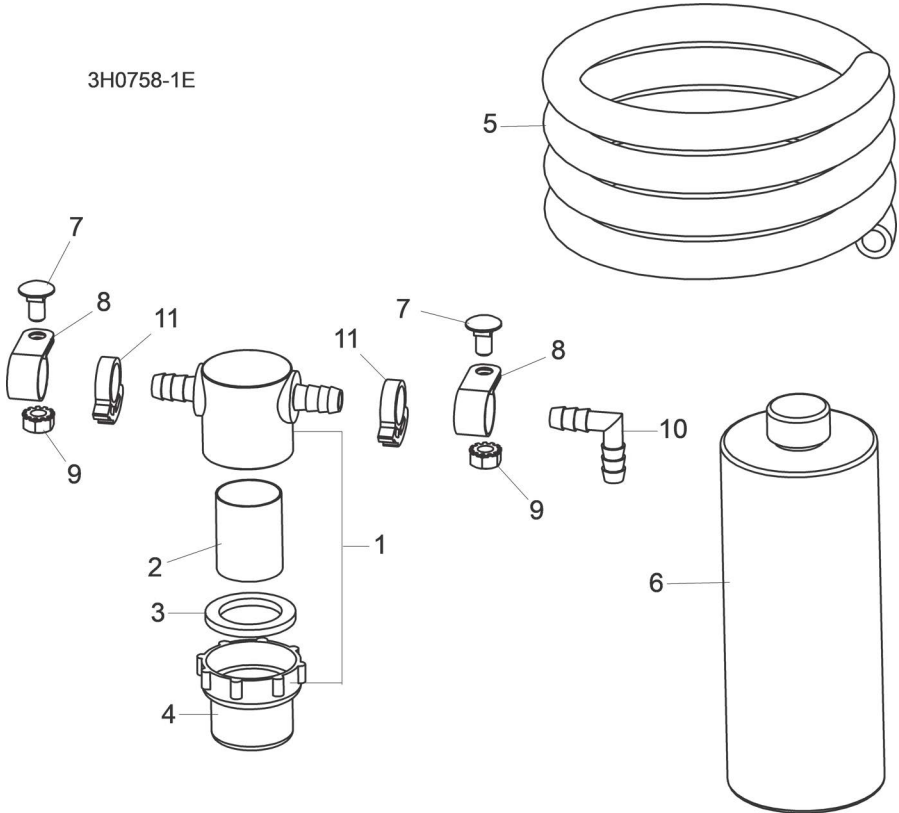

REF	PART #	DESCRIPTION	COMMENTS	QTY.
1	033447	FILTER, PRESSURE LUBE		1
2	033441	Screen Kit, Mesh Filter		1
3	061768	Gasket, Filter Bowl		1
4	003198	Bowl, LubeMizer Filter Replacement		1
5	033455	HOSE, 3/8" X 9/16" X 14"		1
	033446	HOSE, 3/8" X 9/16" X 4'		1
6	ADD-1	LUBRICANT, 4-PAK 60 OZ. BOTTLES LUBEM-IZER		1
7	F05005-33	BOLT, 1/4-20 X 1/2" CARRIAGE		2
8	010748	CLAMP, 5/8" EMT COATED		2
9	F05010-9	NUT, 1/4-20 SELF-LOCKING		2
10	028420	FITTING, 3/8" HOSE BARB ELBOW		1
11	016845	CLAMP, SINGLE SNAP GRIP #38		2

4.4 Filter Assembly (LMS-LX)

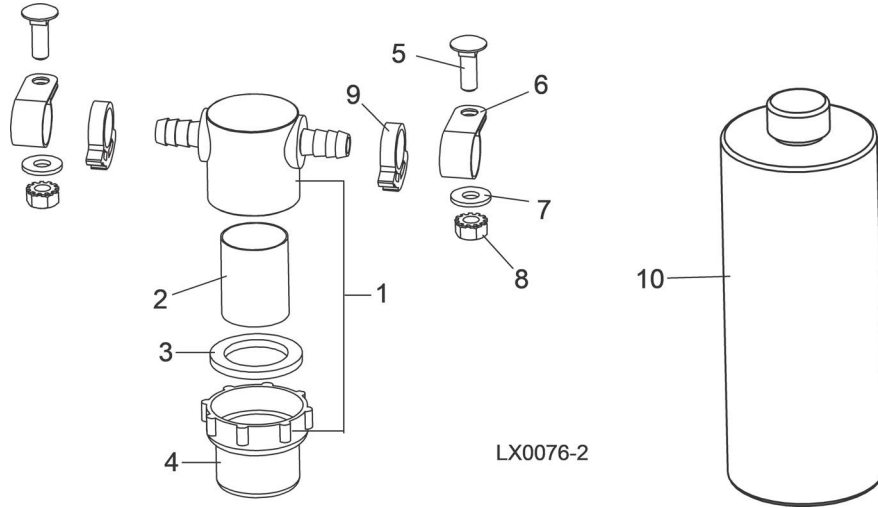

REF	PART #	DESCRIPTION	COMMENTS	QTY.
1	033447	FILTER, PRESSURE LUBE		1
2	033441	Screen Kit, Mesh Filter		1
3	061768	Gasket, Filter Bowl		1
4	003198	Bowl, LubeMizer Filter Replacement		1
5	F05005-113	BOLT, 1/4-20 X 3/4 CARRIAGE		2
6	010748	CLAMP, 5/8" EMT COATED		2
7	F05011-11	WASHER, 1/4 SAE FLAT		2
8	F05010-9	NUT, 1/4-20 SELF-LOCKING		2
9	016845	CLAMP, SINGLE SNAP GRIP #38		2
10	ADD-1	LUBRICANT, 4-PAK 60 OZ. BOTTLES LUBEM-IZER		1

4.5 Blade Guide Block Assembly (LMS-A Only)

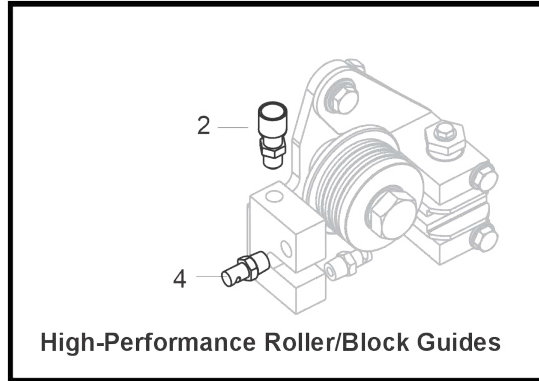
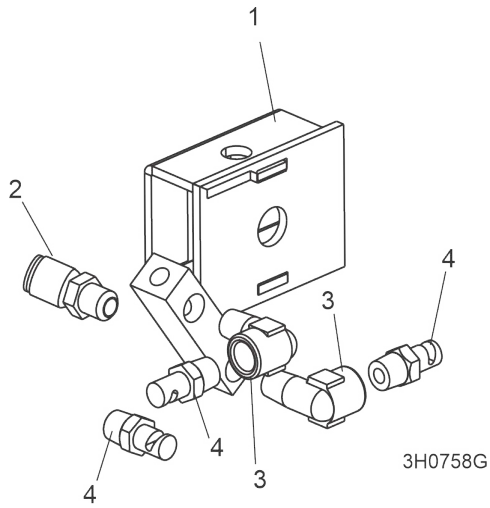

REF	PART #	DESCRIPTION	COMMENTS	QTY.
	003271	GUIDE KIT, PRESSURE LUBE		1
1	033464	Block Weldment, Pressure Lube		1
2	P03078	Fitting, 1/8NPTx1/4Tube, Straight		1
3	033440	Fitting, 1/8" NPT Street Elbow Long		2
4	033479	Nozzle, Blade Lube Spray		3
	P09206	FITTING, 1/16" NPT PLUG		1

4.6 Control Box Assembly

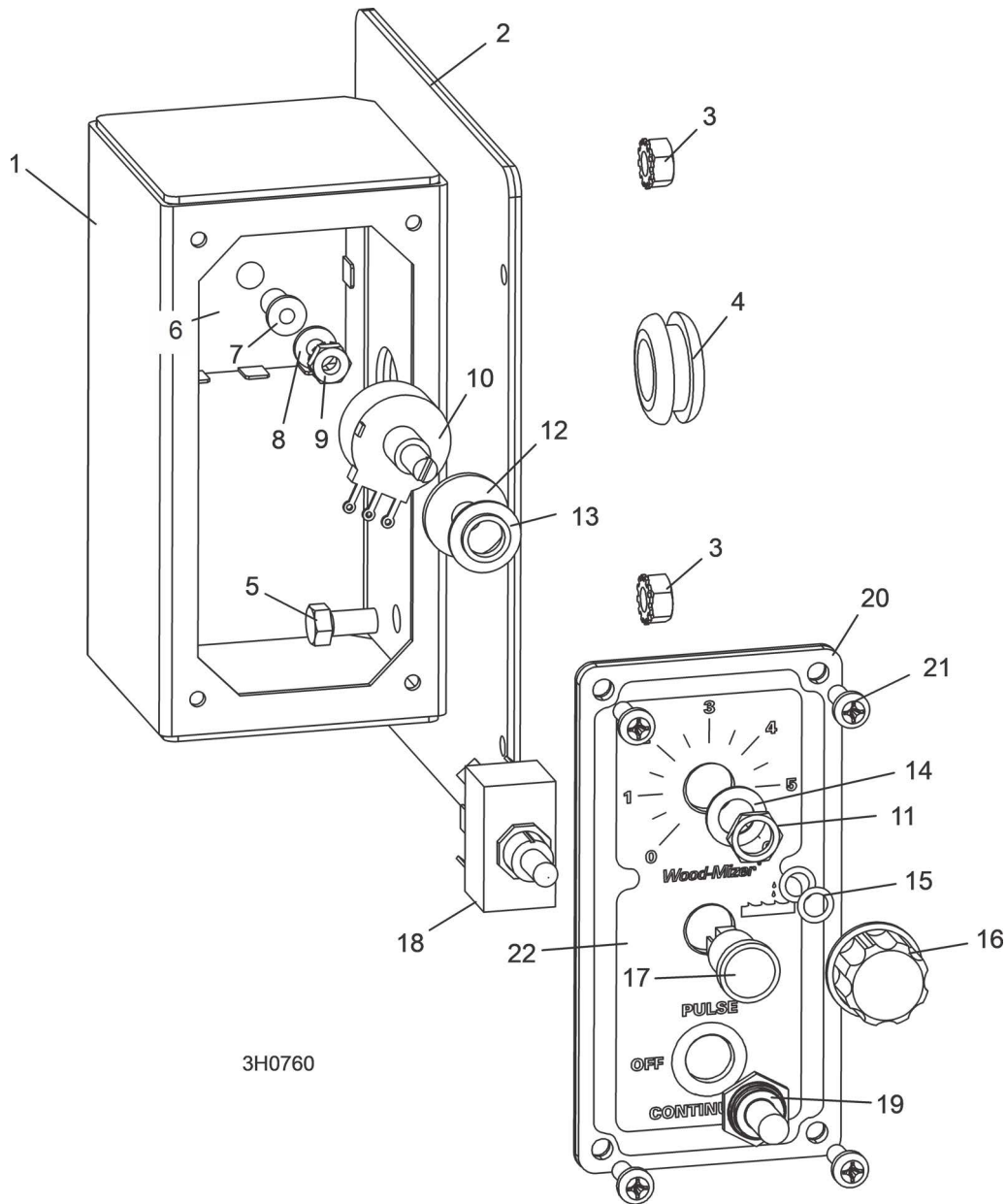

REF	PART #	DESCRIPTION	COMMENTS	QTY.
	025017	CONTROL ASSEMBLY, LMS REPLACEMENT		1
1	033481	Control Box Weldment, LubeMizer		1
2	033495	Panel Weldment, Side	Available in assemblies only.	1
	015274	Gasket, Side Panel	Available in assemblies only.	1
3	F05010-9	Nut, 1/4-20 Self Locking		2
4	033475	Grommet, 5/8" ID x 3/16" Rubber		1
5	F05005-15	Bolt, 1/4-20 x 1/2" Hex Head		2
6	024530	Timer, Repeat Cycle 12VDC 1A .2 - 60 sec		1
7	024409	Insulator, Nylon Screw #10 1/2"		1
8	F05011-41	Washer, #8 SAE Flat		1
9	F05010-14	Nut, #10-24 Self Locking		1

REF	PART #	DESCRIPTION	COMMENTS	QTY.
	024590	Potentiometer Assembly, 500K 2W 10% CP Panel Mount w/Wires		1
10	N/A	Potentiometer	Available in assemblies only.	1
11	N/A	Nut	Available in assemblies only.	1
12	F05011-16	Washer, 5/16" Standard Flat		1
13	033454	Washer, 3/8" ID x 3/4" OD Nylon Shoulder		1
14	033444	Washer, 3/8" ID x 5/8" OD x .032 Thick Nylon		1
15	033476	O-Ring, 7/32" ID #009		2
16	033478	Knob, 1/4" ID Fluted Round Plastic		1
17	E20483	Light, Green 12V .187 Tabs		1
18	024588	Switch, 15A Toggle		1
19	024589	Boot, Toggle Switch Sealing		1
20	033487	Plate, Control Panel Lube	Available in assemblies only.	1
	033488	Gasket, LubeMizer	Available in assemblies only.	1
21	F05015-17	Bolt, #10-24 x 1/2" Pan Head		4
22	033498	Decal, LubeMilzer Control Panel	Available in assemblies only.	1
	024555	Fuseholder, 3-20AATC In-Line w/Cover		2
	024150-2	Fuse, 2AATO Blade Lt Grey		1
	024150-4	Fuse, 4AATO Blade Pink		1

SECTION 5 ELECTRICAL INFORMATION

5.1 Electrical Components

Component	Wood-Mizer Part No.	Description
D1	024123	Diode Assembly, Inductive Kick Protection
F1	024555	Fuseholder, In-Line 3-20 Amp ATC w/Cover
	024150-2	Fuse, 2 Amp ATO Blade Light Grey
F2	024555	Fuseholder, In-Line 3-20 Amp ATC w/Cover
	024150-4	Fuse, 4 Amp ATO Blade Pink
L1	E20483	Light, Green 12V .187 Tabs
P1	033492	Pump Assembly, LubeMizer (Includes D1)
R1	024591	Resistor Assembly, 47K Yellow Lube Timer
SW1	024588	Switch, 15 Amp Toggle
T1	024530	Timer, Repeat Cycle 12VDC 1A .2-60 Seconds
VR1	024590	Potentiometer Assembly, 500K 2W 10% CP Panel Mount

5.2 Electrical Wiring Diagram (Control Circuit)

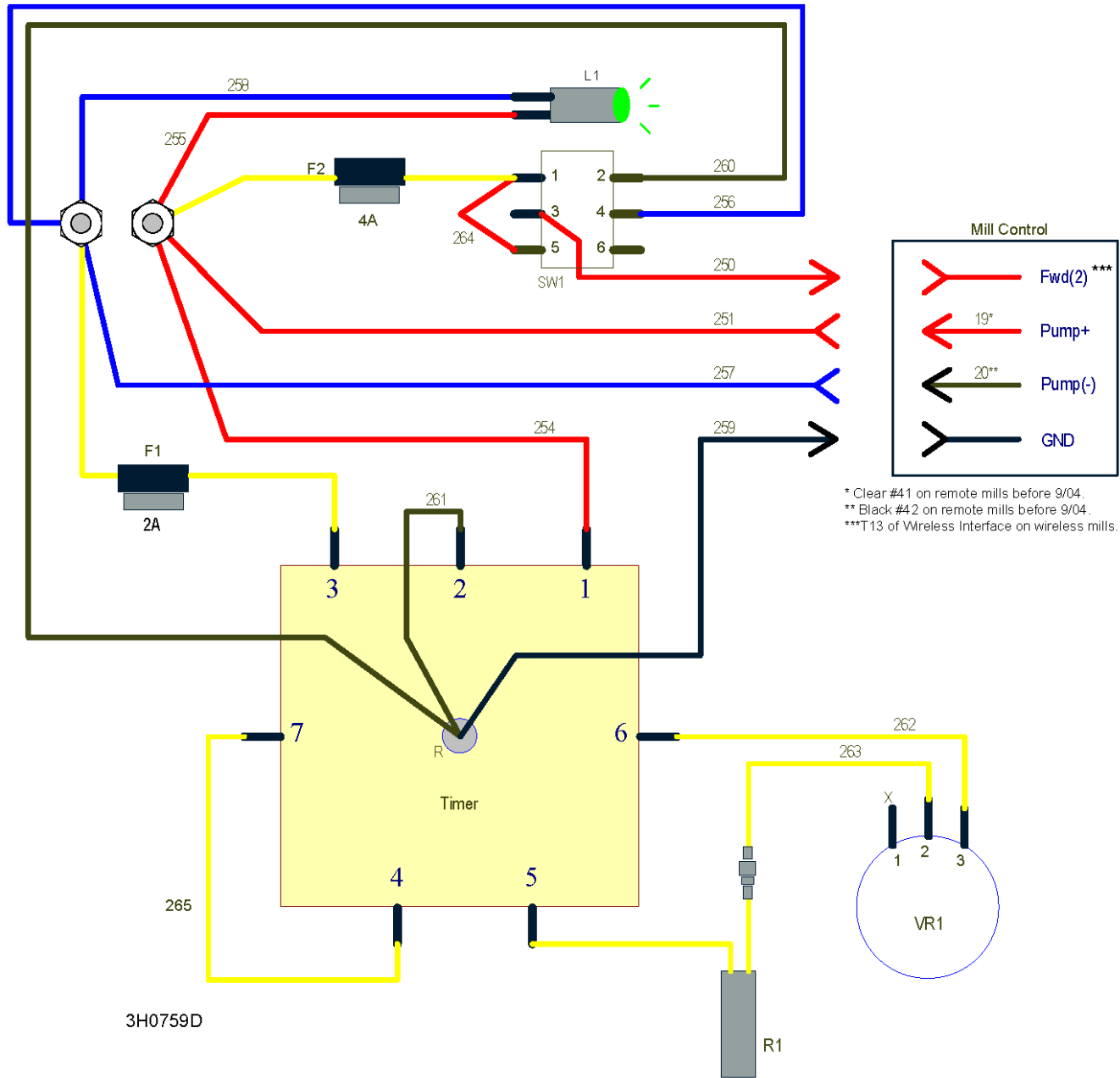

FIG. 5-1

5.3 Electrical Symbol Diagram

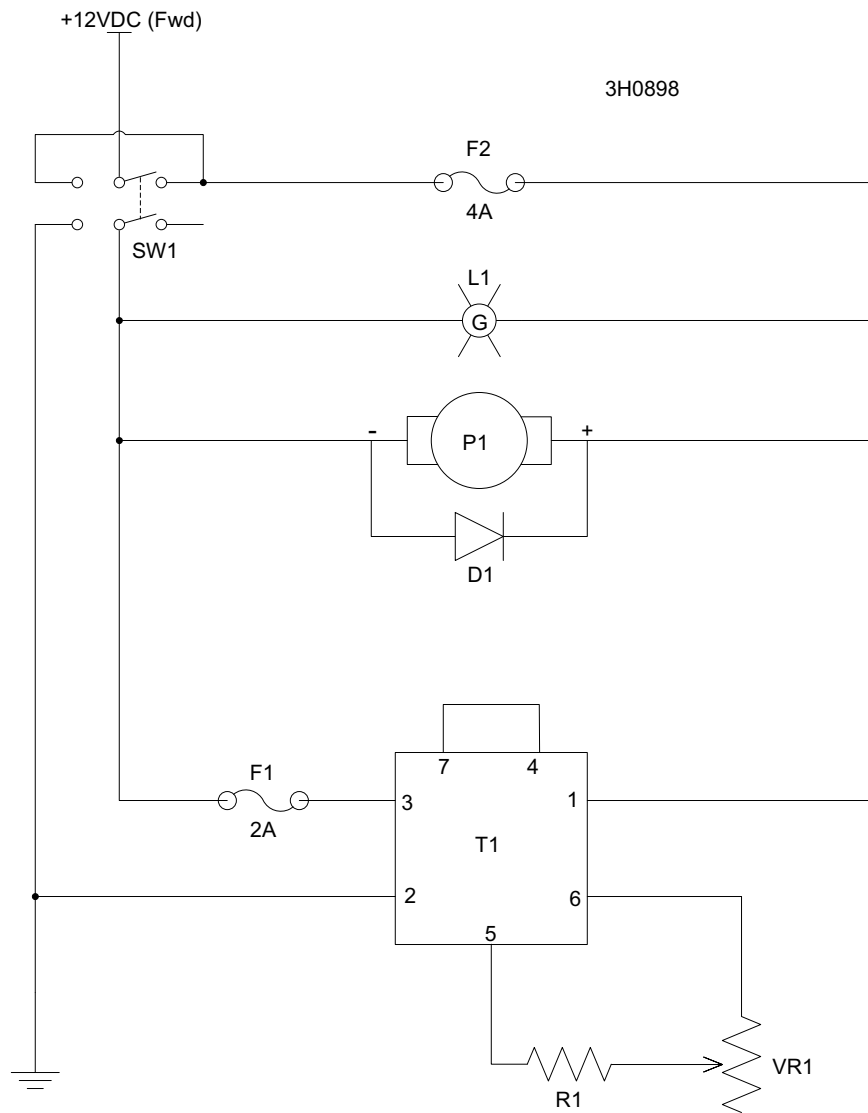

FIG. 5-2