

Autoclutch Option

Safety, Installation,
Operation, & Parts Manual

024643 (Installed Super)
036143 (Installed Std)
003987 (Installed Hydro) Rev. A.00 - A.13
024636 (Boxed Super/Std)
003991 (Boxed Hydro)

Safety is our #1 concern!

September 2007

Form #926

024643 used with all SUPER LT30s, 40s, and 50s.
036143 used with LT30s and 40s.
003987 used with LT40HDD51-H
024636 used with all LT30s, 40s, and 50s.
003991 used with LT40HDD51-H



WARNING! Read and understand this manual before using this machine.

California
Proposition 65 Warning



WARNING: Breathing gas/diesel engine exhaust exposes you to chemicals known to the State of California to cause cancer and birth defects or other reproductive harm.

Always start and operate the engine in a well-ventilated area.
If in an enclosed area, vent the exhaust to the outside.
Do not modify or tamper with the exhaust system.
Do not idle the engine except as necessary.

For more information go to **www.P65warnings.ca.gov**.



WARNING: Drilling, sawing, sanding or machining wood products can expose you to wood dust, a substance known to the State of California to cause cancer. Avoid inhaling wood dust or use a dust mask or other safeguards for personal protection.

For more information go to **www.P65Warnings.ca.gov/wood**.

Active Patents assigned to Wood-Mizer, LLC

Wood-Mizer, LLC has received patents that protect our inventions which are a result of a dedication to research, innovation, development, and design. Learn more at: woodmizer.com/patents

©2024 Wood-Mizer LLC

Printed in the United States of America, all rights reserved. No part of this manual may be reproduced in any form by any photographic, electronic, mechanical or other means or used in any information storage and retrieval system without written permission from

Wood-Mizer, LLC
8180 West 10th Street
Indianapolis, Indiana 46214

SECTION 1 AUTOCLUTCH INSTALLATION

1.1 Manual Clutch Lever Removal 1-1
 1.2 Autoclutch Assembly Installation 1-1
 1.3 Control Component Installation 1-3
 1.4 Wiring Instructions 1-4
 1.5 Turnbuckle Adjustment 1-6
 1.6 Guard Installation 1-8

SECTION 2 OPERATION

SECTION 3 MAINTENANCE

3.1 Autoclutch Belt 3-1
 3.2 Lubrication 3-1
 3.3 Drive Belt Adjustment 3-1
 3.4 Autoclutch Linkage 3-3
 3.5 Troubleshooting 3-4
 3.6 3-4

SECTION 4 REPLACEMENT PARTS

4.1 Autoclutch Assembly (Super/Standard) 4-1
 Rev. A.08+ 4-1
 4.2 Autoclutch Assembly (Hydro) 4-3
 Rev. A.10+ 4-3
 4.3 Autoclutch Assembly (Super/Standard) 4-5
 Rev. A.00 - A.07 4-5
 4.4 Autoclutch Control Parts 4-7
 4.5 Belt Guards 4-8
 Rev. A.11+Retrofit 4-8
 4.6 Belt Guards 4-9
 Rev. A.00 - A.10D.00 4-9

SECTION 5 ELECTRICAL INFORMATION

5.1 Electrical Components 5-1
 5.2 Electrical Diagrams 5-2
 5.3 Electrical Wiring Diagrams (Non-Remote Sawmill Only) 5-4

SECTION 1 AUTOCLUTCH INSTALLATION

NOTE: If your autoclutch option was factory-installed with a new sawmill, you can skip to the next section.

1.1 Manual Clutch Lever Removal

1. Raise the saw head so the clutch mounting hardware is located so it is comfortable for you to work on.
2. Move the saw head forward or back on the frame so you will be able to easily access the clutch turnbuckle.
3. Turn the key switch to the OFF position and remove the key.
4. Remove the battery box lid and disconnect the cable from the negative battery terminal.



DANGER! Before performing any service to this equipment, turn the key to the OFF position, remove the key, and disconnect the cable from the negative terminal on the sawmill battery. Remove the blade from the saw head.

5. If installing the autoclutch to an electric-powered sawmill, disconnect and lock out the incoming power supply.



DANGER! On electric mills, hazardous voltage inside the disconnect box, starter box, and at the electric motor can cause shock, burns, or death. Disconnect and lock out power! Follow all applicable electrical codes.

6. Remove the drive belt housing covers to access the clutch handle and turnbuckle linkage.
7. With the clutch handle disengaged (up), locate the clutch pivot plate where both the long and short turnbuckles are connected.
8. Remove the bolt and nut securing the long and short turnbuckles to the pivot plate.
9. Save the bolt and nut for installation of the Autoclutch turnbuckle.
10. Remove the bolt and nut securing the short turnbuckle to the engine/motor mount.
11. Remove the short turnbuckle assembly.
12. Save the bolt and nut for installation of the Autoclutch turnbuckle.
13. Remove the three bolts securing the clutch handle to the saw head.
14. Remove the clutch handle assembly.

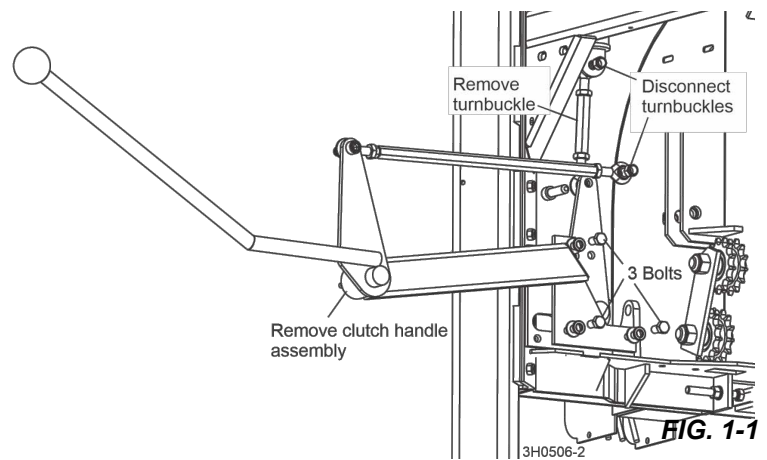

1.2 Autoclutch Assembly Installation

1. Install the provided collar spacer to the autoclutch turnbuckle for the mills equipped with a Kubota, Caterpillar, Yanmar diesel engine or G35 (G38) Kohler gas engine,
2. Loosen the jam nuts and turn the inner and outer links until they separate.
3. Install the spacer collar to the inner link.

4. Reassemble the inner and outer links and tighten the jam nuts.
5. Install the supplied short turnbuckle assembly to the engine/motor mount using the previously removed bolt and nut.
6. Position the turnbuckle so the end with two hexes is on the bottom.

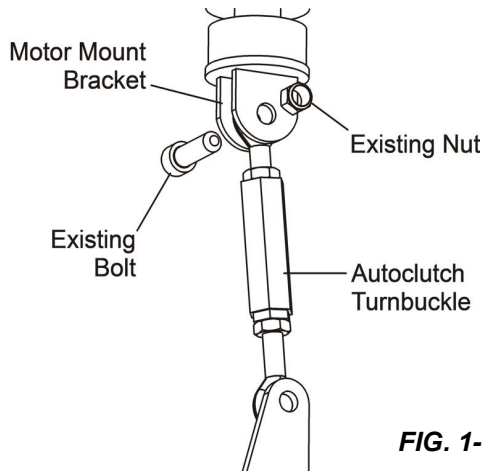

FIG. 1-3

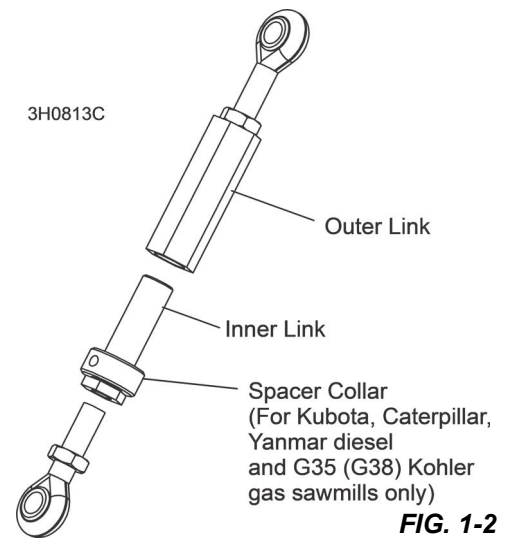

FIG. 1-2

7. Install the autoclutch drive assembly to the sawmill saw head:

SUPER/STANDARD SAWMILLS:

- 1). Remove the three socket head bolts and lock washers from the back of the autoclutch drive assembly.
- 2). Place the rear guard (Rev. D Only) over the three slotted holes located under the engine/motor mount plate.
- 3). Use the three socket head bolts and lock washers to install the autoclutch assembly to the saw head.

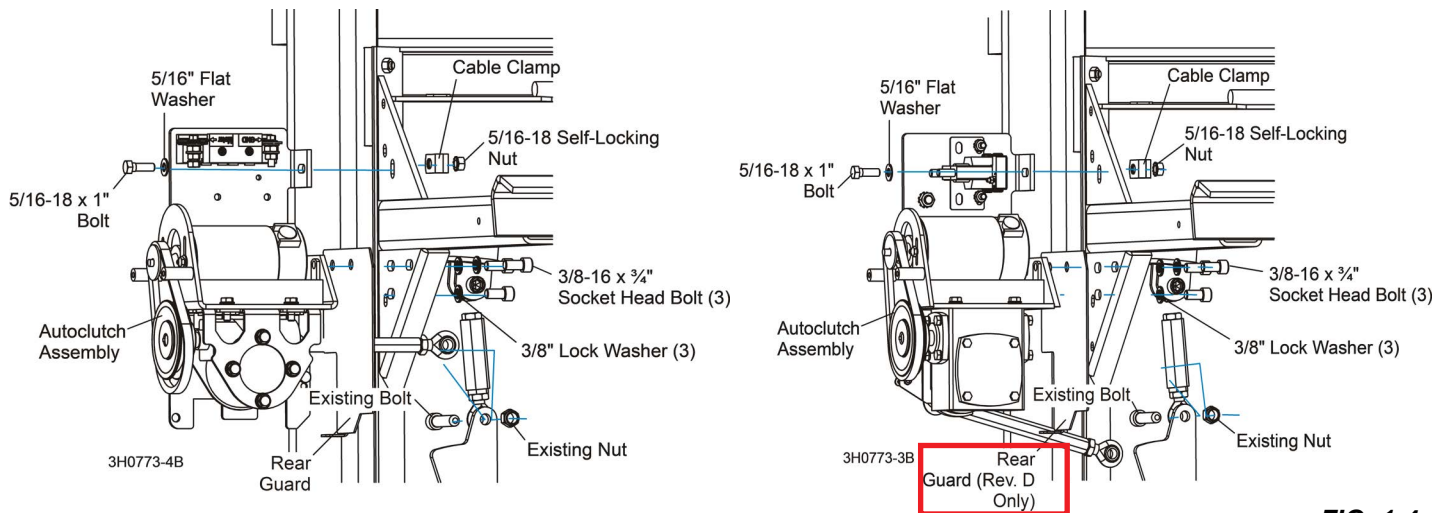

FIG. 1-4

HYDRO SAWMILLS:

- 1). Remove the three hex head bolts and lock washers from the back of the autoclutch drive assembly.
- 2). Remove the three existing mounting bolts, washers and nuts from the rear of the hydro pump bracket.
- 3). Place the autoclutch drive assembly against the pump bracket, aligning the three mounting holes.

- 4). Use the three hex head bolts and lock washers to secure the auto-clutch assembly to the saw head.
8. Use the 5/16-18 x 1" bolt, washer, cable clamp, and lock nut supplied in the bag assembly to secure the top of the auto-clutch bracket to the saw head.
9. Connect the auto-clutch link arm and turn-buckle to the clutch pivot plate using the previously removed bolt and nut.

The turnbuckles will be adjusted after the auto-clutch is installed and operational.

1.3 Control Component Installation

Install the provided circuit breaker and toggle switch to the sawmill control box.

1. Remove the eight screws securing the front panel to the sawmill control box.
2. Lift the panel out and flip around to access the back side (leave all wires attached).
3. Locate the hole for the auto-clutch switch .
4. Carefully use a sharp razor knife to cut a hole in the lexan decal, using the hole in the back of the metal panel as a guide.
5. Be sure the hex nut on the toggle switch is threaded all the way down against the body of the switch.
6. Install the toggle switch through the panel hole.
7. Position the switch body so the switch operates up and down.
8. Secure the switch to the panel with the supplied nylon washer and rubber boot.

NOTE: Sawmills equipped with Caterpillar diesel engines (D34 & D51) already have the circuit breaker described below installed. Skip to Section 1.4 Wiring Instructions.

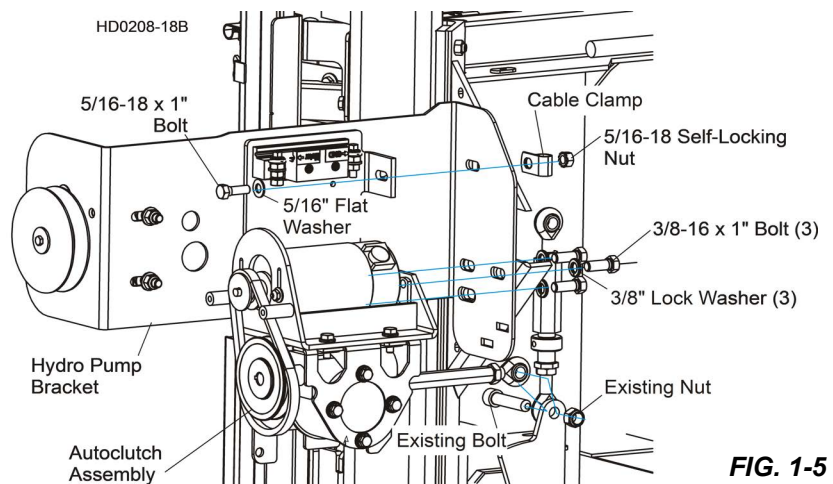

FIG. 1-5

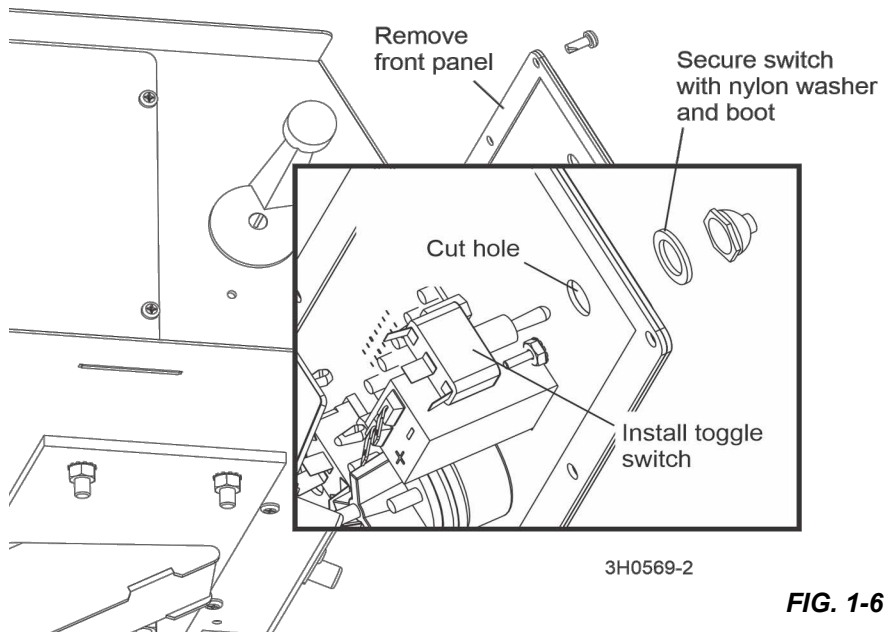

FIG. 1-6

9. Remove the eight screws securing the rear panel to the sawmill control box.
10. Lift the panel out and set on top of the control box, leaving all wires attached.
11. Locate the 3/8" bolt and nut in the rear of the control box toward the right side.
12. Remove the bolt and nut from the control box.
13. Place the provided 30 amp circuit breaker inside the control box and insert the breaker reset button through the hole in the rear of the control box.
14. Secure the breaker to the control box with the boot provided.
15. Peel the back from the provided circuit breaker label and place the decal on the control box under the circuit breaker.

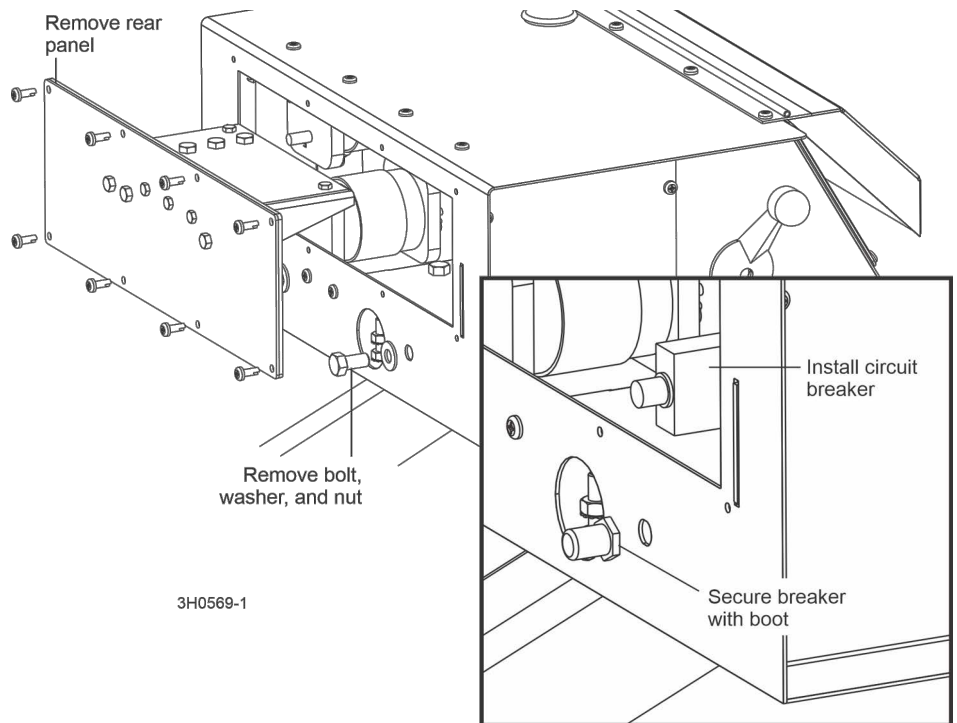

FIG. 1-7

1.4 Wiring Instructions



DANGER! The key switch should still be off, the key removed and the negative battery cable disconnected as stated at the beginning of this section. The incoming power supply of electric-powered sawmills should be disconnected and locked out. Failure to do so will result in serious injury or death.

NOTICE Avoid pinch and pivot points, unnecessary wire bending and open spaces where the wire could get caught by a log, etc. If you have any questions, call Wood-Mizer customer service.

Refer to the appropriate wiring diagram while performing the wiring steps below (See Section 5.3).

1998 and newer model sawmills are pre-wired for the autoclutch option.

1. Locate the harness of four wires (#28, 29, 31, & 32) extending from the top of the conduit connecting the control box to the saw head.

NOTE: On sawmills equipped with Caterpillar diesel engines (D34 & D51), wire #31 is connected to the clutch sensor which operates the engine throttle. Remove the rubber tubing from this connection to add the autoclutch wire connections.

2. Remove any wire ties, tape or cable clamps securing the harness in its storage location.
3. If necessary, install the provided expandable conduit around the four wires and route the assembly through the cable clamp you installed behind the autoclutch assembly.

1 Autoclutch Installation

Wiring Instructions

4. Continue the cable to the autoclutch.

NOTE: The laser option wire #25 may be bundled with the autoclutch option wires. If so, separate wire #25 and return it to the storage location.

5. Pull back the harness conduit to expose the four wires.

6. Connect the 12 gauge black wire (#32) to the ground terminal (GND) on the autoclutch mosfet module.

7. Remove the nut on the ground terminal and slide the wire ring terminal onto the stud.

8. Replace the ground terminal nut.

9. Be sure the ring terminal body does not contact any other surfaces.

NOTE: If your sawmill was built prior to 6/21/99, you will need to replace the ring terminal on wire #32 with the 1/4" terminal supplied so it will fit the mosfet module ground terminal.

10. Use one of the supplied small wire ties to secure the two small black wires connecting the sensors to the mosfet module to wire #32.

11. Leave enough slack in the small wires so the connection to the mosfet module is not tight.

12. Connect the 12 gauge red wire (#31), the red end of the diode wire from the autoclutch mosfet module, the red wire from the capacitor assembly (after Rev. A.09) and the orange autoclutch motor wire.

13. Be sure to maintain the connection of the clutch sensor wire on D34 & D51 models.

NOTE: If your sawmill was built prior to 6/21/99, you will need to replace the ring terminal on wire #31 with the #10 terminal supplied so it will fit the other wire terminals.

14. Place the four (or five for D34/D51) wire terminals together and secure with the provided #10-24 x 3/8" screw and lock nut.

15. Slide the provided rubber cap over the terminal connection and stretch the loop around the end of the cap to secure.

16. Connect one of the 14 gauge red wires (#28) to the black (or red prior to 4/02) wire from the autoclutch engage sensor.

These wires have quick connects which simply snap together.

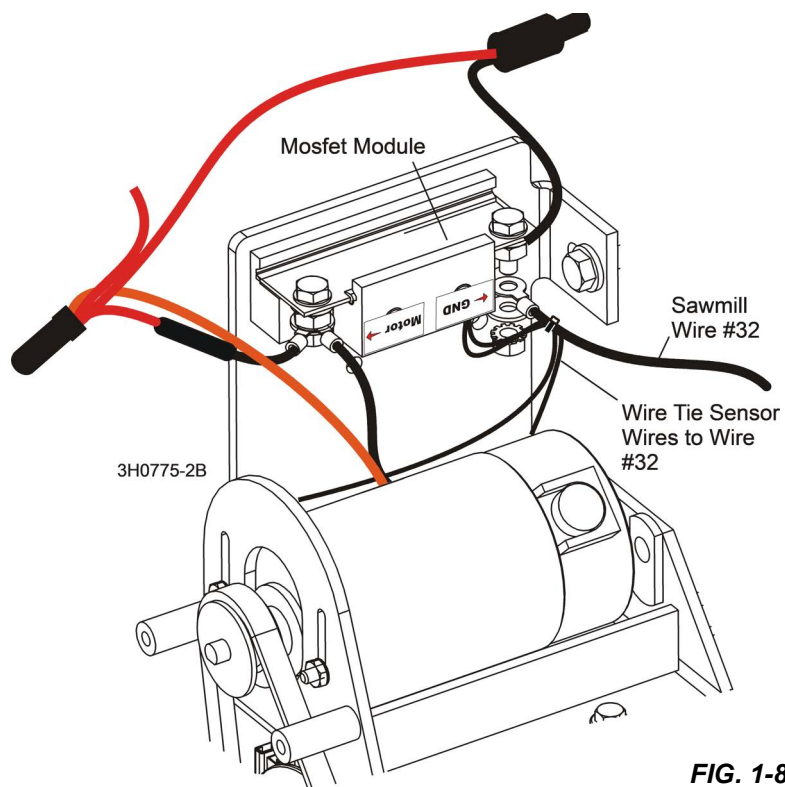

FIG. 1-8

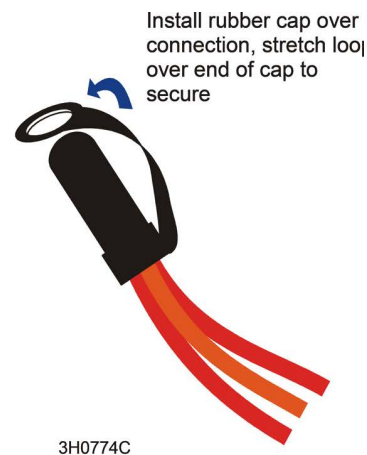
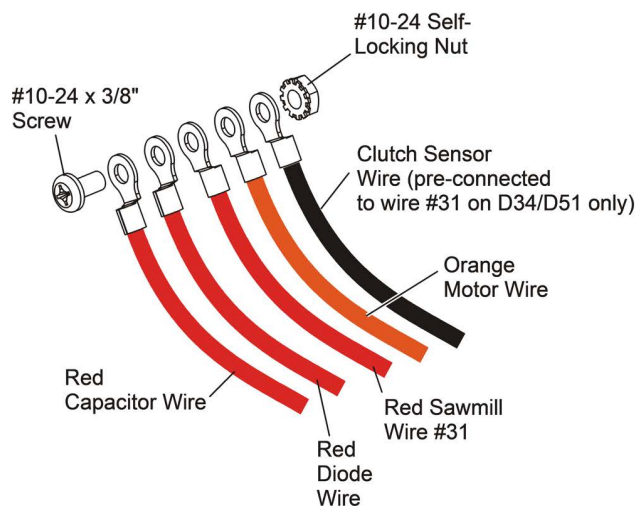

FIG. 1-9

17. Connect the other 14 gauge red wire (#29) to the black (or red prior to 4/02) wire from the autoclutch disengage sensor in the same manner.
18. In the control box, locate the harness of four wires (#28, 29, 31, & 32).
19. Remove any wire ties, tape, or cable clamps securing the harness in its storage location.
20. Pull back the harness conduit to expose the four wires.

NOTE: Black wire #32 should be pre-installed to the ground terminal stud in the bottom of the control box.

21. Connect the 14 gauge red wire (#28) to the bottom terminal of the autoclutch toggle switch.
22. Slide the wire terminal onto the switch terminal tab.
23. Connect the other 14 gauge red wire (#29) to the top terminal of the autoclutch toggle switch in the same manner.
24. Connect the pre-installed red wire from the middle terminal of the autoclutch toggle switch to the Accessory circuit breaker.

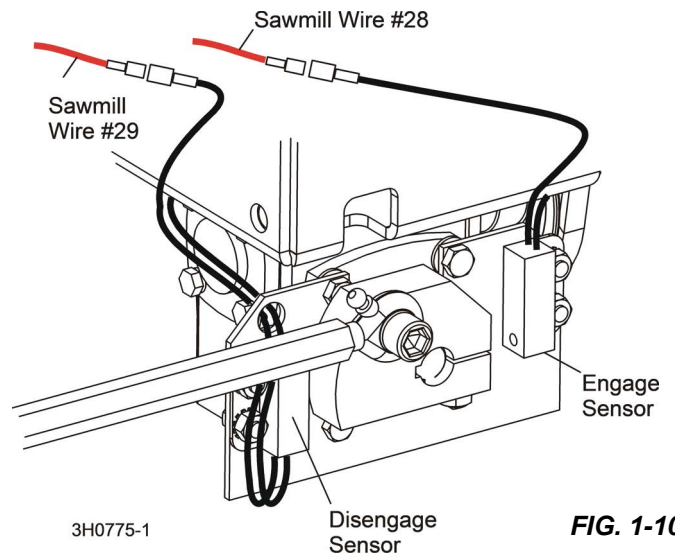

FIG. 1-10

The Accessory circuit breaker is the second from the left as you face the front of the control box.

25. Remove the nut from the front circuit breaker terminal stud (closest to the front of the control box).
26. Slide the wire ring terminal onto the circuit breaker terminal stud and replace the nut.
27. Be sure to maintain all other wire connections on the circuit breaker terminal.
28. Connect the 12 gauge red wire (#31) to the bottom terminal of the 30 amp circuit breaker you installed to the back wall of the control box.
29. Slide the wire connector onto the circuit breaker tab.

NOTE: Wire #31 is already connected to the existing circuit breaker on D34 & D51 models with Caterpillar diesel engines.

30. Connect the pre-installed red wire from the top terminal of the circuit breaker to the Accessory post on the key switch.
31. Remove the ACC terminal nut, slide the wire ring terminal over the key switch terminal and replace the nut.
32. Be sure to maintain all other wire connections on the key switch terminal.
33. Use the supplied wire ties to secure all harnesses and/or wires to prevent interference with any moving components of the saw head or in the control box.
34. Replace the front and rear control box panels and screws.
35. Reconnect the negative battery cable and replace the battery box cover.
36. Place the key in the key switch and turn to the "ACC" position.
37. Continue to the next section for autoclutch adjustment procedure.

1.5 Turnbuckle Adjustment

1. Raise the autoclutch toggle switch until the autoclutch motor quits cycling. The autoclutch should pivot the engine/motor mount up, engaging the drive belt.
2. Check the drive belt tension (refer to your engine manual for proper drive belt tension specifications).
3. If adjustment is needed, loosen the bottom lock nut on the autoclutch turnbuckle.

4. Tighten the drive belt by adjusting the inner or outer rod link to lengthen the turnbuckle.
5. Loosen the drive belt by adjusting the inner or outer rod link to shorten the turnbuckle.
6. Tighten the bottom lock nut to secure in place.
7. Place a straight edge between the upper and lower clutch pivot centers.
8. Make sure the middle pivot is aligned to the straight edge.
9. If it is not, adjust the autoclutch link arm.

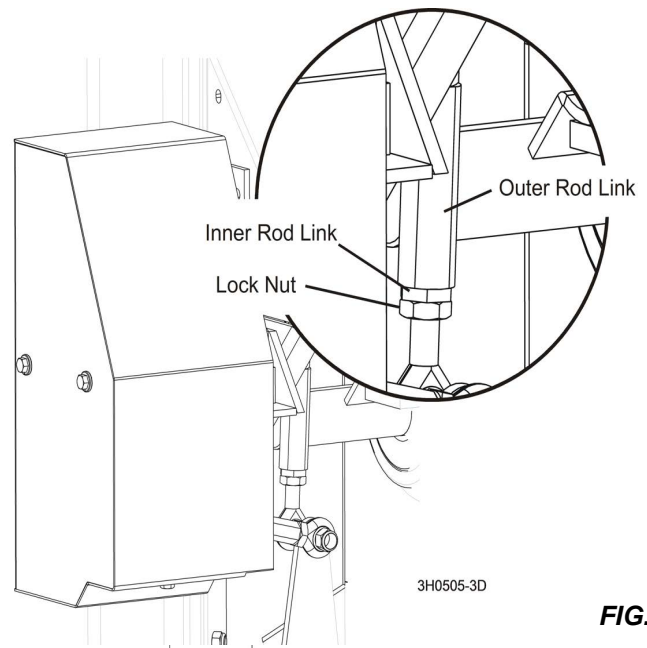
**FIG. 1-11**

10. To adjust, turn the autoclutch link arm to adjust the rod end in or out as required and repeat Step 3. **Prior to Rev. A.12 Only:** Disassembly of one end of the autoclutch link arm is required to adjust the arm.
11. Lower the autoclutch toggle switch until the autoclutch motor quits cycling.

The autoclutch should pivot the engine/motor mount down, disengaging the drive belt.

12. With the drive belt disengaged, recheck the autoclutch turnbuckle.
13. Measure the distance between the outer rod link the inner rod link or spacer collar.
14. Adjust the brake strap as needed (refer to your operator's manual for specific adjustment procedures).
15. If the distance is less than 1/16", tighten the brake strap.
16. If the distance is more than 1/4", loosen the brake strap.

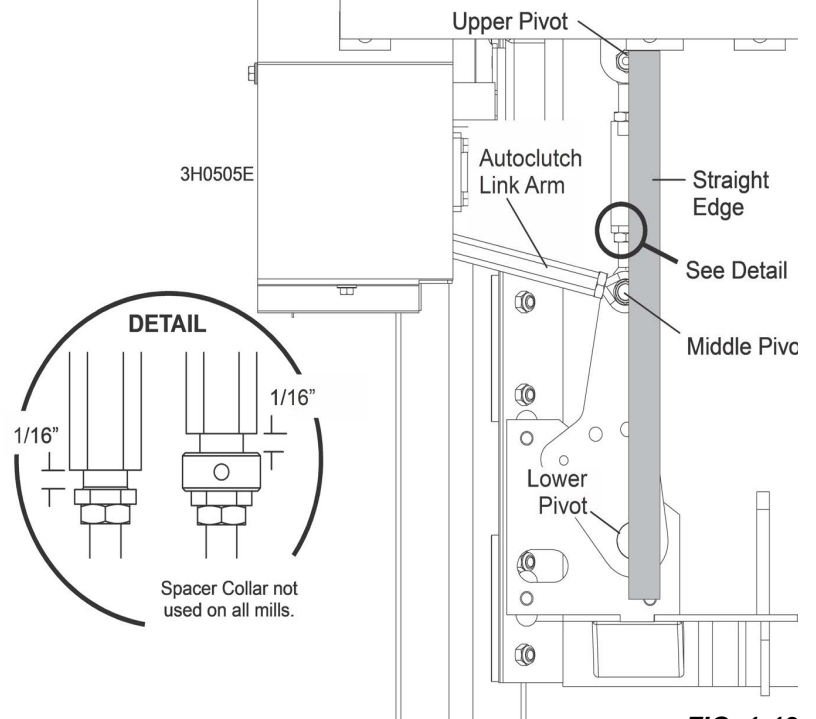
**FIG. 1-12**

1.6 Guard Installation

1. If not already installed, install the front and rear Autoclutch guards:

SUPER/STANDARD SAWMILL:

Use the supplied 1/4-20 x 1/2" bolts and split lock washers to secure the front guard in place.

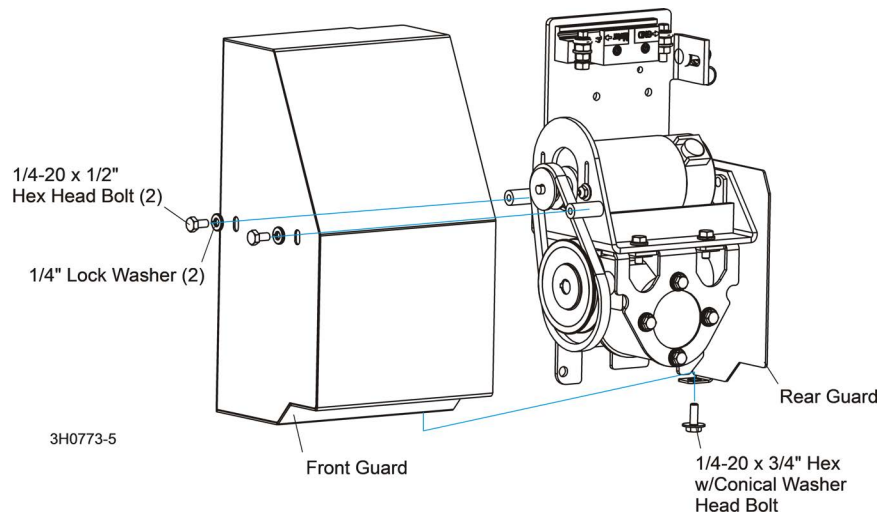

FIG. 1-13

HYDRO SAWMILL:

1. Use the supplied 1/4-20 x 1/2" bolts and split lock washers to secure the front guard in place.
2. Secure the back guard to the front guard from underneath using the supplied 1/4-20 x 3/4" bolt.
3. Secure the back guard to the hydro pump bracket using the two 1/4-20 x 3/4" carriage head bolts, lock washers and lock nuts provided.
4. Replace all saw head covers.
5. Use the provided lower belt guard assembly to replace the original lower guard.
6. Assemble the lower belt guard to the mount with the 1/4-20 x 1/2" hex head bolts and flat washers provided.

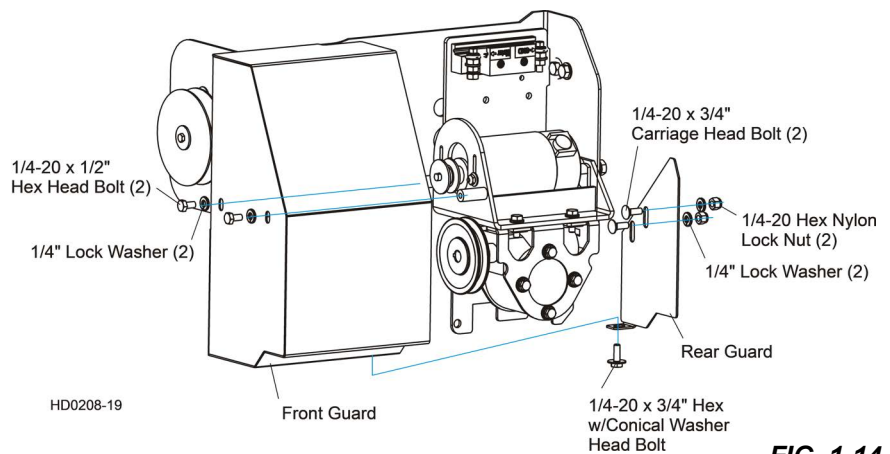

FIG. 1-14

CAUTION! When replacing or installing guards, be careful not to pinch any wiring. Damage to the wiring and/or electrical components may result.

7. Install the guard assembly to the sawmill using six 1/4-20 x 3/4" hex head bolts with conical washers.

1 Autoclutch Installation

Guard Installation

8. If your sawmill is not equipped with a board return mechanism mounted to the saw head, install the provided auxiliary guard plate as shown.

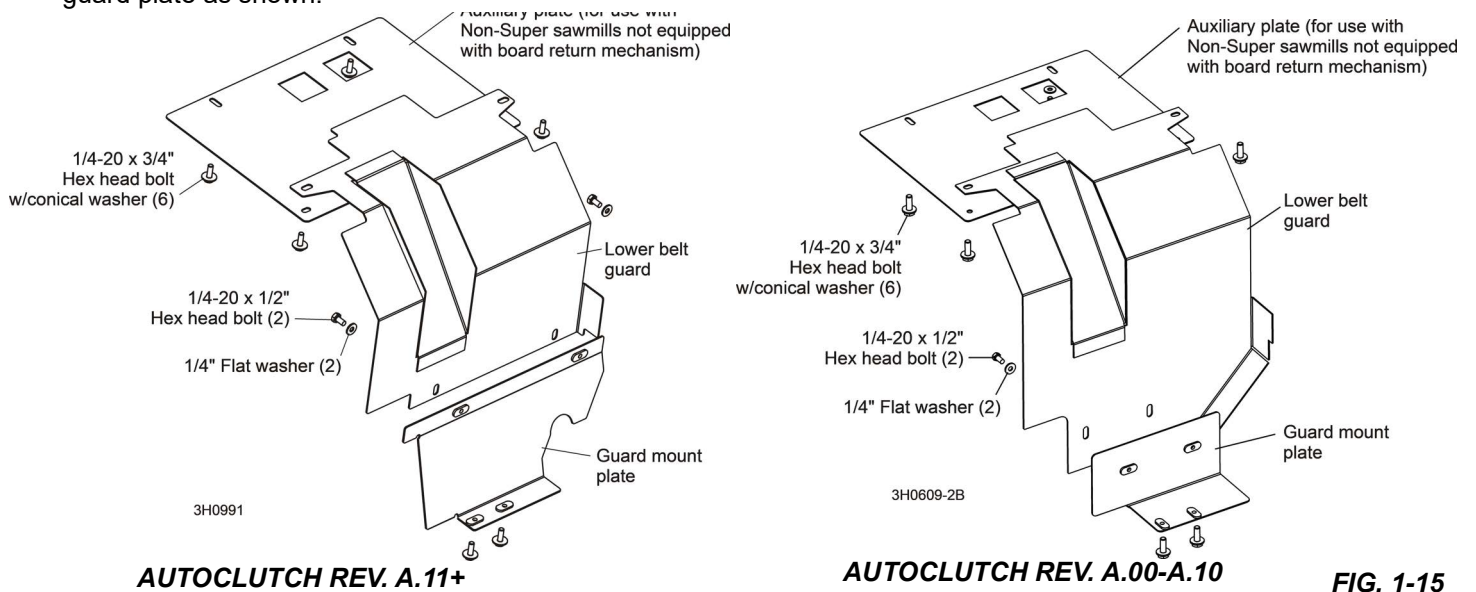

SECTION 2 OPERATION

1. Instead of pulling a handle to engage the blade, push the toggle switch on the control panel up.
2. Hold the switch up until the clutch motor stops completely.

The autoclutch mechanism will disengage the brake, rev the motor to full throttle, and start the blade spinning.

! **DANGER!** Keep all persons out of the path of moving equipment and logs when operating sawmill or loading and turning logs. Failure to do so will result in serious injury.

3. Stop the blade and engage the blade brake by pushing the toggle switch down; this will also return the engine to idle.

NOTE: Be sure the toggle switch stays in the up or down position. The boot on the switch may spring the switch back to neutral. Hold the switch in position until the remote clutch motor completes its cycle.

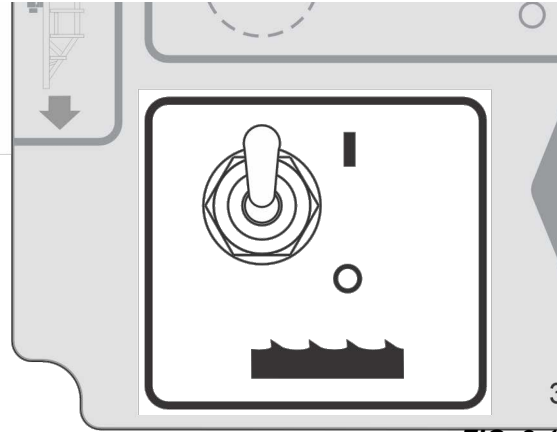

FIG. 2-1

SECTION 3 MAINTENANCE



DANGER! Disconnect and lock out power supply before performing autoclutch installation! Follow all applicable electrical codes.

Ensure all electrical installation, service and/or maintenance work is performed by a qualified electrician and is in accordance with applicable electrical codes.

Before performing any service to this equipment, turn the key to the OFF position, remove the key, and disconnect the battery ground terminal.

3.1 Autoclutch Belt

1. Tighten the clutch belt as necessary to prevent slippage.
2. Remove the three cover bolts and washers and remove the cover.
3. Loosen the clutch motor mounting bolts and slide the motor up to tighten the belt.
4. Inspect the belt for wear or cracks and replace as necessary.

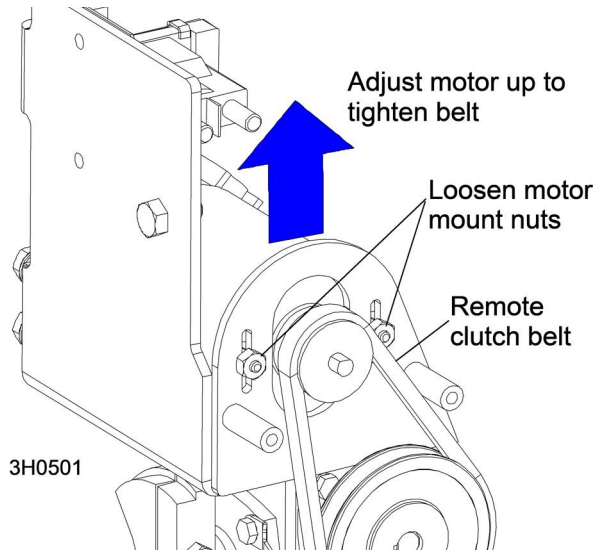

FIG. 3-1

3.2 Lubrication

Rev. A.00 - A.07 Only:

1. Check the clutch gear box oil level.
2. Remove the level plug at the rear of the gear box.

The oil level should be right at the plug hole.

1. Drain and refill the gearbox after the first 100 hours of sawmill operation.
2. Use a synthetic gear oil such as Mobil SHC 634.
3. Repeat every 5000 hours or once a year, whichever comes first.

Prior to Rev. A.12 Only:

1. Lubricate the autoclutch linkage every 100 hours of operation.
2. Apply a NLGI No. 2 grade lithium grease to the fitting at the end of the clutch linkage connected to the gear box.

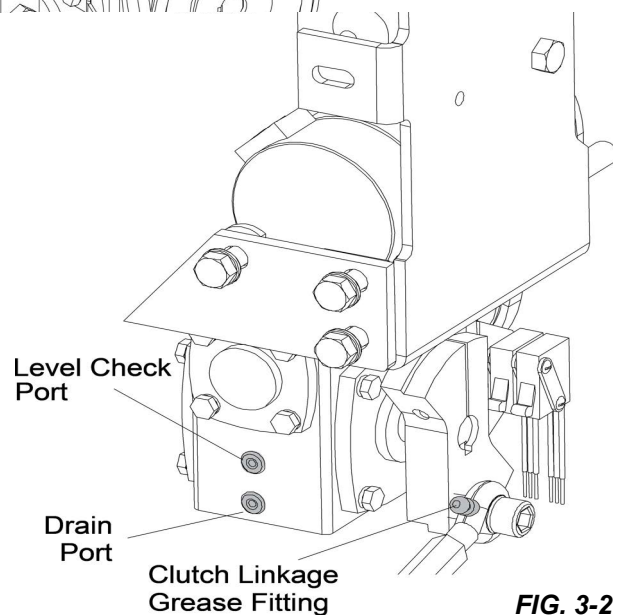

FIG. 3-2

3.3 Drive Belt Adjustment



WARNING! DO NOT adjust the engine drive belts or belt support bracket with the engine running. Doing so may result in serious injury.

Measure the belt tension with a gauge **every 50 hours** of operation.

Wood-Mizer offers a belt tension gauge (Part No. 016309) that will let you accurately measure the belt tension.

Engine /Motor	New Belt Installation/New Sawmill Operation				Subsequent Adjustment		
	Deflection Inches (mm)	Installation Force lbs. (kg)	Check After First	Acceptable Force lbs. (kg)	Then Check Every	Deflection Inches (mm)	Installation Force lbs. (kg)
G24/G25/G26/G28	7/16" (11mm)	14 lbs. (6.35kg)	20 hrs	14 lbs. (6.35kg)	50 hrs	7/16" (11mm)	14 lbs. (6.35kg)
D30/D33/D34/D35/D36	7/16" (11mm)	18 lbs. (8.16kg)	5 hrs	18 lbs. (8.16kg)	50 hrs	7/16" (11mm)	18 lbs. (8.16kg)
D40/D42/D47/D51/E25/G35/G36/G38	7/16" (11mm)	18 lbs. (8.16kg)	5 hrs	18 lbs. (8.16kg)	50 hrs	7/16" (11mm)	18 lbs. (8.16kg)

1. Remove the two belt covers located underneath the engine.
2. Loosen the jam nut at the bottom of the turnbuckle.
3. Turn the hex on the inner link rod clockwise (as viewed from the bottom) to tighten the belt, counterclockwise to loosen the belt.
4. Once you reach the maximum adjustment using the bottom jam nut/inner link rod, adjust the linkage by loosening the top jam nut and turning the turnbuckle clockwise as viewed from the top.

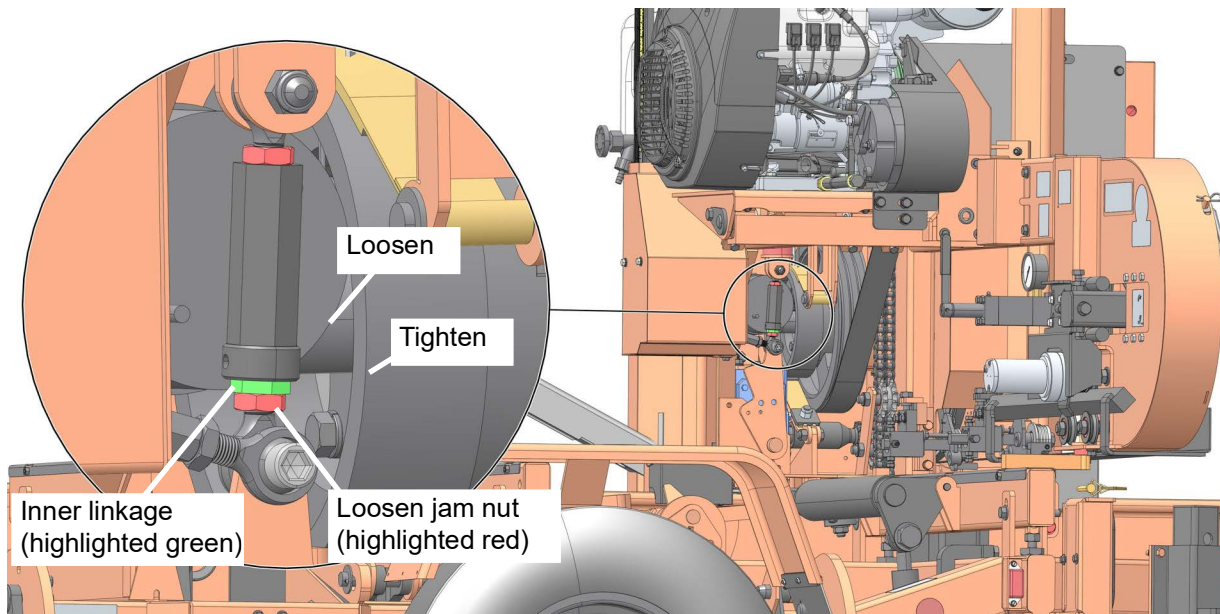

FIG. 3-3

5. Check all belts for wear; replace any damaged or worn belts **as needed**.
6. **Gas/Diesel Engines Only:** After tensioning the drive belt, check throttle cable tension and adjust if necessary.

The throttle cable should be tensioned just enough so that the engine revs as soon as the autoclutch is engaged. The throttle linkage should NOT affect engine RPM while the autoclutch handle is disengaged.

NOTE: A properly adjusted throttle will extend the cable spring 1/4" to 3/8" (6.4 - 9.5 mm) when running and have a slight amount of slack in the cable when idling. Check the drive belt support after adjusting drive belt tension.

DRIVE BELT SUPPORT

1. Adjust the drive belt support **as needed**.

The drive belt support is designed to extend belt life. The bracket should be adjusted to NOT touch the drive belt when the clutch is engaged, AND to hold the drive belt away from the engine pulley when the clutch handle is disengaged (up position).

2. Ensure the motor is not running.
3. Loosen the adjustment bolts.
4. Position the bracket so that the prong is close to, but does not touch, the drive belt with the clutch handle engaged (approximately 1/8-1/16" [3-1.5mm]).
5. Retighten the adjustment bolts to 25-27 foot pounds (34-37 newton meters).

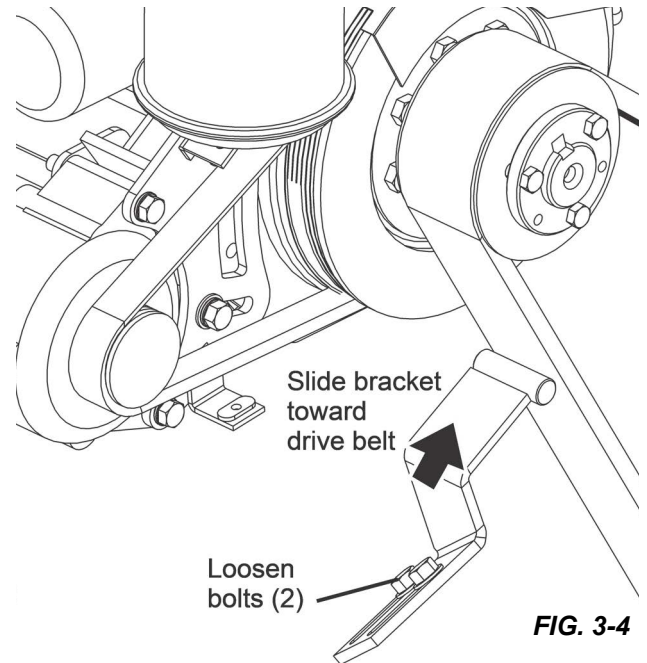

FIG. 3-4

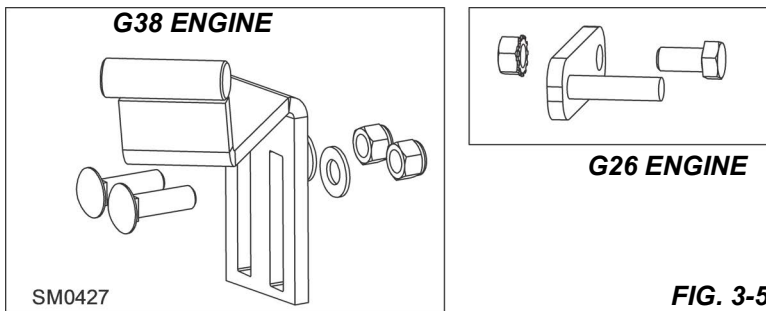

FIG. 3-5

3.4 Autoclutch Linkage

After every drive belt or brake strap adjustment, check the autoclutch linkage.

1. Remove the blade from the sawmill.
2. Remove the inside belt guard and push the autoclutch toggle switch up to engage the drive belts.
3. Place a straight edge between the upper and lower clutch pivot centers.
4. Make sure the middle pivot is aligned to the straight edge.
5. If it is not, adjust the autoclutch link arm by turning the autoclutch link arm to adjust the rod end in or out as required and repeat Step 3. **Prior to Rev. A.12 Only:** Disassembly of one end of the autoclutch link arm is required to adjust the arm.
6. Lower the autoclutch toggle switch until the autoclutch motor quits cycling.

The autoclutch should pivot the engine/motor mount down, disengaging the drive belt.

7. With the drive belt disengaged, recheck the autoclutch turnbuckle.
8. Measure the distance between the outer rod link the inner rod link or spacer collar.
9. Make sure the distance is not less than 1/16" (it can vary for different sawmills). See FIG. 3-6.

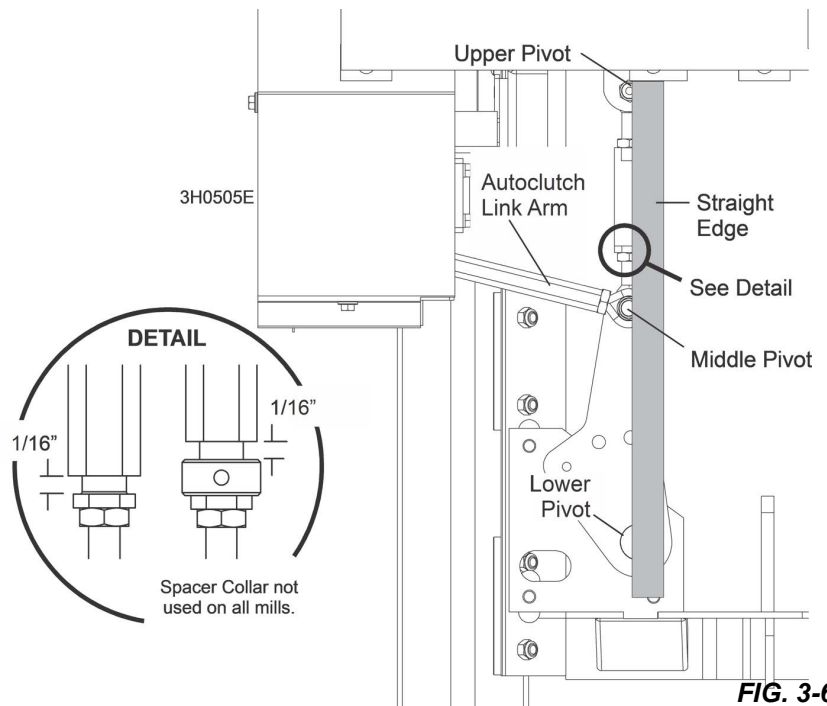

FIG. 3-6

3.5 Troubleshooting

Problem	Cause	Solution
Autoclutch will not stop; continues to engage and	Bad mosfet module	Use a diode meter to check diode wire assembly for proper operation. Replace diode and/or mosfet module as necessary.
	Bad sensor	Check sensor with ohm meter. Pass a piece of ferrous metal across sensor and check that the sensor opens. Replace sensor as necessary.
	Metal debris buildup causing sensor to open	Clear metal debris from sensors.
Autoclutch will not engage or disengage	15Amp or 30Amp breaker tripped; 15Amp ACC Breaker (CB4) tripped	Check and reset as needed
	Bad sensor	Check sensor with Ohm meter. Pass a piece of ferrous metal across sensor and check that the sensor opens. Replace sensor as necessary.
	Metal debris buildup causing sensor to open	Clear metal debris from sensors.
	Bad Autoclutch motor, motor brushes or armature	Disconnect both motor leads from circuit. Use an ohm meter to check continuity between the motor leads. If no continuity, inspect brushes, brush springs and armature. Rebuild or replace motor as necessary.
	Motor overheating	Drive belts are too tight. Check belt tension and adjust properly.
	Gearbox binding	Check gearbox oil. Refill or replace as necessary.
	Damaged switch	Replace switch
Autoclutch will engage or disengage only (won't do	Bad sensor	Check sensor with ohm meter. Pass a piece of ferrous metal across sensor and check that the sensor opens. Replace sensor as necessary.
	Metal debris buildup causing sensor to open	Clear metal debris from sensors.

3.6

SECTION 4 REPLACEMENT PARTS

4.1 Autoclutch Assembly (Super/Standard)

Rev. A.08+

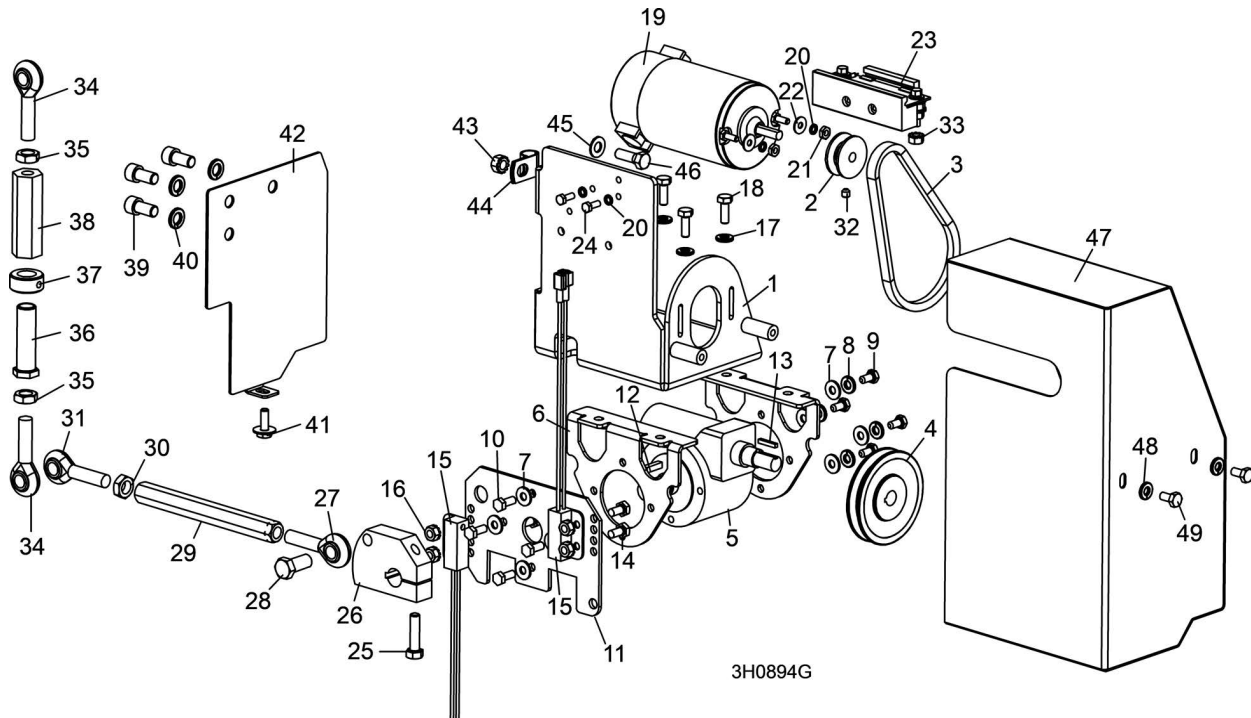

REF	PART #	DESCRIPTION	COMMENTS	QTY.
	024620	CLUTCH ASSEMBLY, AUTOMATIC		1
1	016216	Mount Weldment, Autoclutch Gearbox		1
2	015074	Sheave, 1.42 x .32		1
3	015076	Belt, 3L150		1
4	015075	Sheave, 0K30 x 1/2		1
	036786	Gearbox Assembly, Autoclutch		1
5	036764	Gearbox, 61:1 512 Reducer		1
6	036807	Mount Weldment, Autoclutch Gearbox		2
7	F05011-11	Washer, 1/4" SAE Flat		8
8	F05011-14	Washer, 1/4" Split Lock		4
9	F05005-99	Bolt, M6 x 12 Full Thread Grade 8.8 Hex Head		4
10	F05004-219	Bolt, M6 x 1 x 16mm Hex Head		4
11	036785	Plate, Sensor Mount		1
12	S03060	Key, 3/16" Sq. x 3/4" Long		1
13	036803	Key, 1/8" Sq. x 3/4" Long		1
14	F05005-99	Bolt, M6 x 12 Hex Head Full Thread Grade 8	Bolts F05005-15 replaced with M6 bolts F05005-99 (9/09).	4
15	024627	Sensor Assembly, Proximity Magnetic		2
16	F05010-200	Nut, M6-1.0 Hex Nylon Lock	Nuts F05010-9 replaced with F05010-200 (9/09).	4
17	F05011-14	Washer, 1/4" Split Lock		4
18	F05005-123	Bolt, 1/4-20 x 3/4" Hex Head Grade 5		4
19	016021	Motor Assembly, Autoclutch Replacement		1

REF	PART #	DESCRIPTION	COMMENTS	QTY.
	034002	Brush Kit, Autoclutch Leeson Motor External		1
20	F05011-20	Washer, #10 Split Lock		4
21	F05010-27	Nut, #10-32 Hex		2
22	F05011-18	Washer, #10 SAE Flat		2
	052791	Module Kit, Autoclutch Upgrade	Use Upgrade Kit 052791 to replace original 024618.	1
23	024618	Module Assembly, Mosfet 4X Autoclutch	Available in assemblies only.	1
	024163	Capacitor Assembly, 1000uF with 1/4" Ring Terminals		1
	061052	Diode Assembly, Autoclutch Gate		1
	F05089-3	Tie Wrap, 3/16" x 6" Black UV		1
	052791-1260	Instruction Sheet, Autoclutch Mosfet Installation		1
24	F05004-27	Screw, 10-24 x 1/2" Unslotted Hex Head Stainless Steel Machine		2
25	F05006-21	Bolt, 5/16-24 x 1 1/4" Hex Head		1
26	016323	Cam, Auto Clutch		1
27	P11578	Rod End, 7/16-20 Left-Hand Male	Right-Hand Rod End 015254 replaced Left-Hand Rod End P11578 (Rev. A.12).	1
28	F05007-151	Screw, 7/16-20 x 1" Hex Head Grade 5		1
29	006622	Rod, Clutch Engagement	Engagement Rod 015062 replaced with Rod 006622 (Rev. A.12).	1
30	F05010-38	Nut, 7/16-20 Jam		1
31	P11579	Rod End, 7/16-20 Right-Hand Male		1
32	F05005-105	Screw, 1/4-28 x 1/4" Cup Point Socket Set		1
33	F05010-9	Nut, 1/4-20 Self Locking		1
	036644	Cap, Rubber Wire		1
34	P11579	ROD END, 7/16-20 RIGHT-HAND MALE		2
35	F05010-38	NUT, 7/16-20 HEX JAM		2
	016325	ROD KIT, AUTOCLUTCH INNER/OUTER LINK		1
36	015070	Rod, Autoclutch Inner Link	Available in assemblies only.	1
37	P05035	Collar, 5/8" ID Lock	Collar provides increased range of adjustment on Kubota, Caterpillar & Yanmar diesel and G38 sawmills ONLY .	1
38	015071	Rod, Autoclutch Outer Link	Available in assemblies only.	1
39	F05005-104	BOLT, 3/8-16 X 3/4" SOCKET HEAD		3
40	F05011-4	WASHER, 3/8" SPLIT		3
41	F05005-134	BOLT, 1/4-20 X 3/4" HEX HEAD W/CONICAL WASHER		1
42	016232	GUARD, AUTOCLUTCH BACK		1
43	F05010-20	NUT, 5/16-18 SELF-LOCKING HEX		1
44	P07584	CLAMP, 1/2" COATED EMT		1
45	F05011-17	WASHER, 5/16" SAE FLAT		1
46	F05006-1	BOLT, 5/16-18 X 1" HEX HEAD		1
47	015735	GUARD WELDMENT, AUTOCLUTCH		1
48	F05011-14	WASHER, 1/4" SPLIT LOCK		2
49	F05005-15	BOLT, 1/4-20 X 1/2" HEX HEAD		2

4.2 Autoclutch Assembly (Hydro)

Rev. A.10+

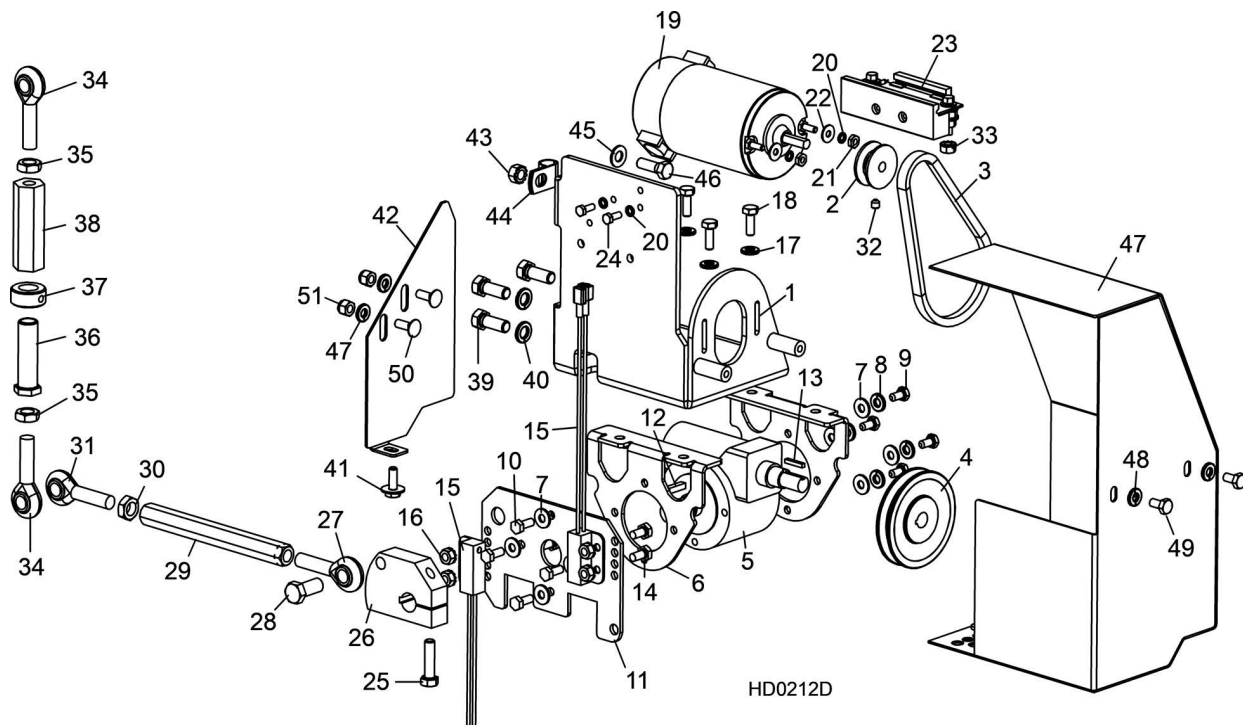

REF	PART #	DESCRIPTION	COMMENTS	QTY.
	024620	CLUTCH ASSEMBLY, AUTOMATIC		1
1	016216	Mount Weldment, Autoclutch Gearbox		1
2	015074	Sheave, 1.42 x .32		1
3	015076	Belt, 3L150		1
4	015075	Sheave, 0K30 x 1/2		1
	036786	Gearbox Assembly, Autoclutch		1
5	036764	Gearbox, 61:1 512 Reducer		1
6	036807	Mount Weldment, Autoclutch Gearbox		2
7	F05011-11	Washer, 1/4" SAE Flat		8
8	F05011-14	Washer, 1/4" Split Lock		4
9	F05005-99	Bolt, M6 x 12 Full Thread Grade 8.8 Hex Head		4
10	F05004-219	Bolt, M6 x 1 x 16mm Hex Head		4
11	036785	Plate, Sensor Mount		1
12	S03060	Key, 3/16" Sq. x 3/4" Long		1
13	036803	Key, 1/8" Sq. x 3/4" Long		1
14	F05005-99	Bolt, M6 x 12 Hex Head Full Thread Grade 8	Bolts F05005-15 replaced with M6 bolts F05005-99 (9/09).	4
15	024627	Sensor Assembly, Proximity Magnetic		2
16	F05010-200	Nut, M6-1.0 Hex Nylon Lock	Nuts F05010-9 replaced with F05010-200 (9/09).	4
17	F05011-14	Washer, 1/4" Split Lock		4
18	F05005-123	Bolt, 1/4-20 x 3/4" Hex Head Grade 5		4
19	016021	Motor Assembly, Autoclutch Replacement		1
	034002	Brush Kit, Autoclutch Leeson Motor External		1

REF	PART #	DESCRIPTION	COMMENTS	QTY.
20	F05011-20	Washer, #10 Split Lock		4
21	F05010-27	Nut, #10-32 Hex		2
22	F05011-18	Washer, #10 SAE Flat		2
	052791	Module Kit, Autoclutch Upgrade		1
23	024618	Module Assembly, Mosfet 4X Autoclutch	Available in assemblies only.	1
	024163	Capacitor Assembly, 1000uF with 1/4" Ring Terminals		1
	061052	Diode Assembly, Autoclutch Gate		1
	F05089-3	Tie Wrap, 3/16" x 6" Black UV		1
	052791-1260	Instruction Sheet, Autoclutch Mosfet Installation		1
24	F05004-27	Screw, 10-24 x 1/2" Unslotted Hex Head Stainless Steel Machine		2
25	F05006-21	Bolt, 5/16-24 x 1 1/4" Hex Head		1
26	016323	Cam, Auto Clutch		1
27	P11578	Rod End, 7/16-20 Left-Hand Male	Right-Hand Rod End 015254 replaced Left-Hand Rod End P11578 (Rev. A.12).	1
28	F05007-151	Screw, 7/16-20 x 1" Hex Head Grade 5		1
29	006622	Rod, Clutch Engagement	Engagement Rod 015062 replaced with Rod 006622 (Rev. A.12).	1
30	F05010-38	Nut, 7/16-20 Jam		1
31	P11579	Rod End, 7/16-20 RH Male		1
	036644	Cap, Rubber Wire		1
32	F05005-105	Screw, 1/4-28 x 1/4" Socket Head Cup Point Set		1
33	F05010-9	Nut, 1/4-20 Self Locking		1
34	P11579	ROD END, 7/16-20 RIGHT-HAND MALE		2
35	F05010-38	NUT, 7/16-20 HEX JAM		2
	016325	ROD KIT, AUTOCLUTCH INNER/OUTER LINK		1
36	015070	Rod, Autoclutch Inner Link	Available in assemblies only.	1
37	P05035	Collar, 5/8" ID Lock		1
38	015071	Rod, Autoclutch Outer Link	Available in assemblies only.	1
39	F05007-87	BOLT, 3/8-16 X 3/4" HEX HEAD GRADE 8		3
40	F05011-4	WASHER, 3/8" SPLIT		3
41	F05005-134	BOLT, 1/4-20 X 3/4" HEX HEAD W/CONICAL WASHER		1
42	003989	GUARD, AUTOCLUTCH BACK (HYDRO)		1
43	F05010-20	NUT, 5/16-18 SELF-LOCKING HEX		1
44	P07584	CLAMP, 1/2" COATED EMT		1
45	F05011-17	WASHER, 5/16" SAE FLAT		1
46	F05006-1	BOLT, 5/16-18 X 1" HEX HEAD		1
47	003988	GUARD WELDMENT, AUTOCLUTCH (HYDRO)		1
48	F05011-14	WASHER, 1/4" SPLIT LOCK		4
49	F05005-15	BOLT, 1/4-20 X 1/2" HEX HEAD		2
50	F05005-113	BOLT, 1/4-20 X 3/4" CARRIAGE HEAD		2
51	F05010-69	NUT, 1/4-20 HEX NYLON LOCK		2

4.3 Autoclutch Assembly (Super/Standard)

Rev. A.00 - A.07

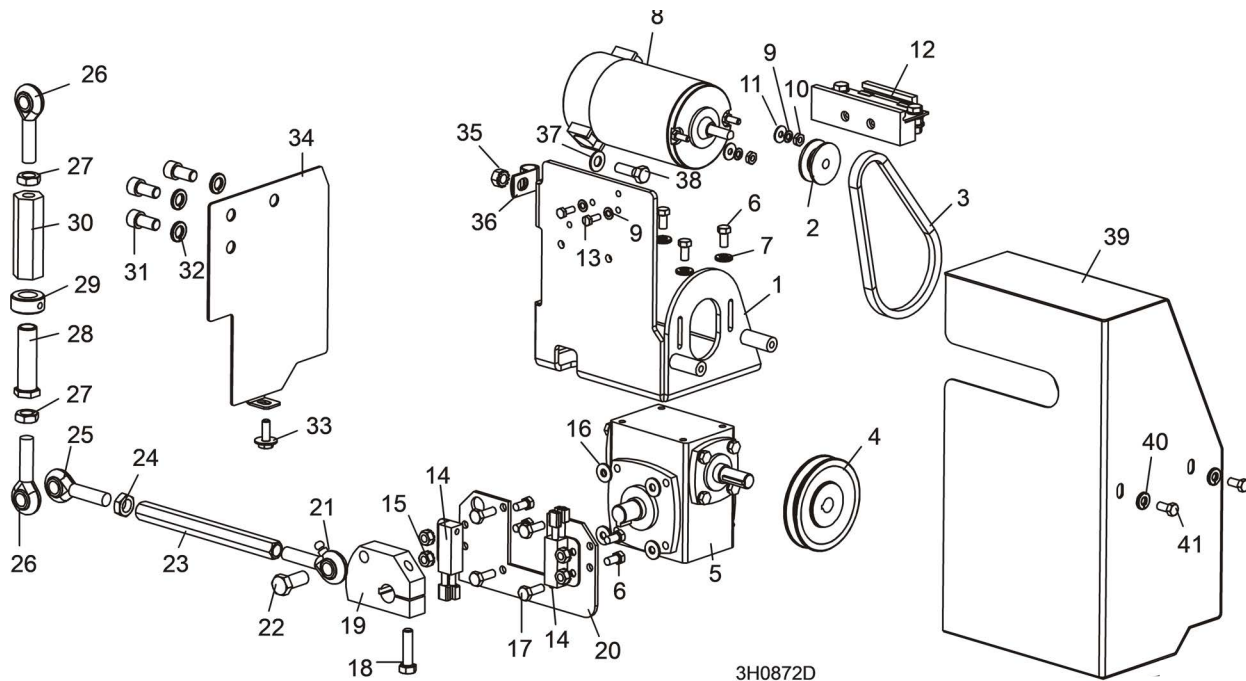

REF	PART #	DESCRIPTION	COMMENTS	QTY.
	024620	CLUTCH ASSEMBLY, AUTOMATIC		1
1	016216	Mount Weldment, Autoclutch Gearbox		1
2	015074	Sheave, 1.42 x .32		1
3	016219	Belt, 3L140		1
4	015075	Sheave, 0K30 x 1/2		1
5	036786	Gearbox, 60:1 I034	Available in assemblies only. 015067 replaced with 036786 (Rev. A.08).	1
6	F05005-15	Bolt, 1/4-20 x 1/2" Hex Head		8
7	F05011-14	Washer, 1/4" Split Lock		4
8	016706	Motor Assembly, Autoclutch Replacement		1
	034002	Brush Kit, Autoclutch Leeson Motor External	Use 034002 Brush Kit for Leeson motors supplied after 12/00 (Rev. A.04). 4.	1
	A12198	Brush Kit, Autoclutch Owosso Motor External	Use A12198 Brush Kit for Owosso motor originally supplied prior to Rev. A.0	1
9	F05011-20	Washer, #10 Split Lock		2
10	F05010-27	Nut, #10-32 Hex		2
11	F05011-18	Washer, #10 SAE Flat	Added at Rev. A.06 .	2
12	052791	Module Kit, Autoclutch Upgrade	Use Kit 052791 to replace original Mosfet Module 024618.	1
	024163	Capacitor Assembly, 1000uF with 1/4" Ring Terminals		1
	061052	Diode Assembly, Autoclutch Gate		1

REF	PART #	DESCRIPTION	COMMENTS	QTY.
	F05089-3	Tie Wrap, 3/16" x 6" Black UV		1
	052791-1260	Instruction Sheet, Autoclutch Mosfet Installation		1
13	F05004-27	Screw, 10-24 x 1/2" Unslotted Hex Head Stainless Steel Machine		2
14	024627	Sensor Assembly, Proximity Magnetic		2
15	F05010-200	Nut, 1/4-20 Self Locking	Nuts F05010-9 replaced with (9/09).	4
16	F05011-11	Washer, 1/4" SAE Flat		4
17	F05005-99	Bolt, 1/4-20 x 3/4" Full Thread Hex Head Cap	Bolts F05005-1 replaced with M6 bolts (9/09).	4
18	F05006-21	Bolt, 5/16-24 x 1 1/4" Hex Head		1
	046567	Cam Kit, Autoclutch Retro w/Bracket		1
19	016323	Cam, Auto Clutch	Available in assemblies only.	1
20	016324	Plate, Sensor Mounting	Available in assemblies only.	1
21	015254	Rod End, R/H w/Grease Zerk		1
22	F05007-151	Screw, 7/16-20 x 1" Hex Head Grade 5		1
23	006622	Rod, Clutch Engagement	015062 replaced with Rod 006622 (Rev. A.12).	1
24	F05010-38	Nut, 7/16-20 Jam		1
25	P11579	Rod End, 7/16-20 RH Male		1
26	015254	ROD END, 7/16-20 RIGHT-HAND MALE	Right-Hand Rod End replaced Left-Hand Rod End P11578 (Rev. A.12).	2
27	F05010-38	NUT, 7/16-20 HEX JAM		2
	016325	ROD KIT, AUTOCLUTCH INNER/OUTER LINK		1
28	015070	Rod, Autoclutch Inner Link	Available in assemblies only.	1
29	P05035	Collar, 5/8" ID Lock	Lock collar added Rev. A.02. Collar is used for adjustment on Kubota, Caterpillar & Yanmar diesel and G38 sawmills ONLY .	1
30	015071	Rod, Autoclutch Outer Link	Available in assemblies only.	1
31	F05005-104	BOLT, 3/8-16 X 3/4" SOCKET HEAD		3
32	F05011-4	WASHER, 3/8" SPLIT		3
33	F05005-134	BOLT, 1/4-20 X 3/4" HEX HEAD W/CONICAL WASHER		1
34	016232	GUARD, AUTOCLUTCH BACK		1
35	F05010-20	NUT, 5/16-18 SELF-LOCKING HEX		1
36	P07584	CLAMP, 1/2" COATED EMT		1
37	F05011-17	WASHER, 5/16" SAE FLAT		1
38	F05006-1	BOLT, 5/16-18 X 1" HEX HEAD		1
39	015735	GUARD WELDMENT, AUTOCLUTCH		1
40	F05011-14	WASHER, 1/4" SPLIT LOCK	Bottom slot in guard, bolt and washer removed (Rev. A.07).	2
41	F05005-15	BOLT, 1/4-20 X 1/2" HEX HEAD		2

4.4 Autoclutch Control Parts

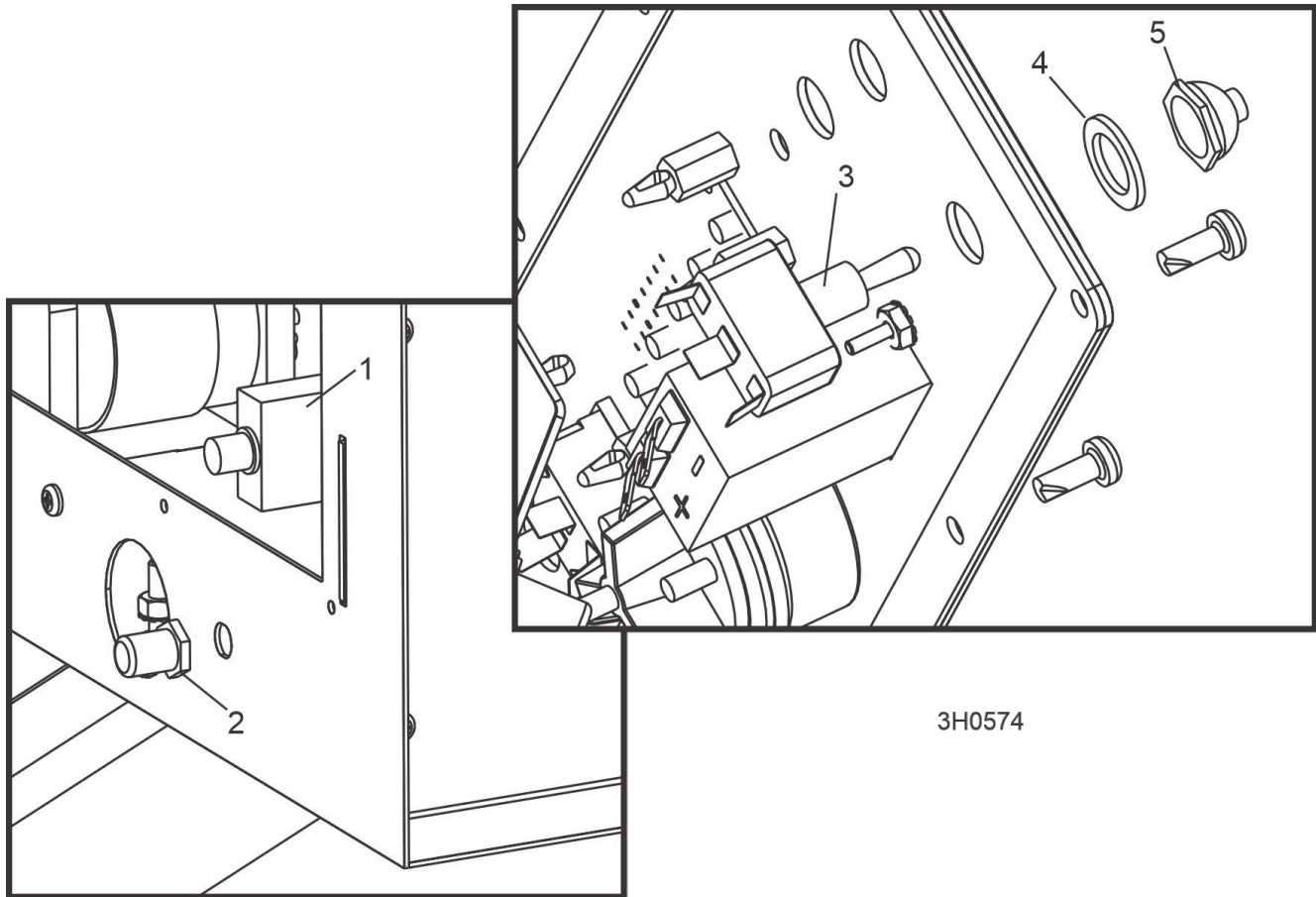

3H0574

REF	PART #	DESCRIPTION	COMMENTS	QTY.
1	024246	BREAKER, 30A MANUAL RESET PANEL MOUNT		1
2	021253	BOOT, CIRCUIT BREAKER		1
3	051346	SWITCH, ON/ON TOGGLE SPDT	051346 replaces 015665 On/Off/On Toggle Switch supplied before 8/03.	1
4	P05251-1	WASHER, 1/2" ID X 3/4" OD X 1/16" THICK NYLON		1
5	P02575	BOOT, TOGGLE SWITCH		1

4.5 Belt Guards

Rev. A.11+Retrofit

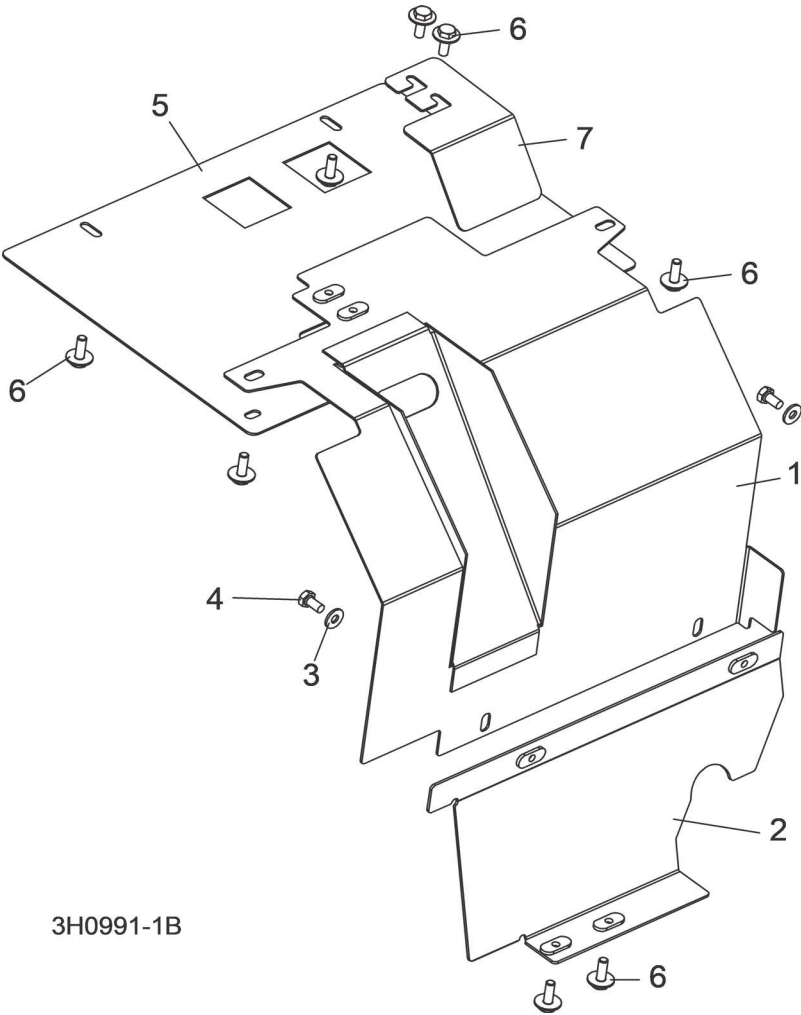

3H0991-1B

REF	PART #	DESCRIPTION	COMMENTS	QTY.
1	006026	GUARD WELDMENT, AUTOMATIC CLUTCH		1
2	006025	MOUNT WELDMENT, CLUTCH GUARD		1
3	F05011-11	WASHER, 1/4" SAE FLAT		2
4	F05005-15	BOLT, 1/4-20 X 1/2" HEX HEAD		2
5	016089	PLATE, LOWER BELT AUXILIARY GUARD	Auxiliary plate required for Non-Super models without board return mechanism.	1
6	F05005-134	BOLT, 1/4-20 X 3/4" HEX HEAD WITH CONICAL WASHER		8
7	074752	PLATE, LT40 BELT GUARD COVER	Added (9/15).	1

4.6 Belt Guards

Rev. A.00 - A.10D.00

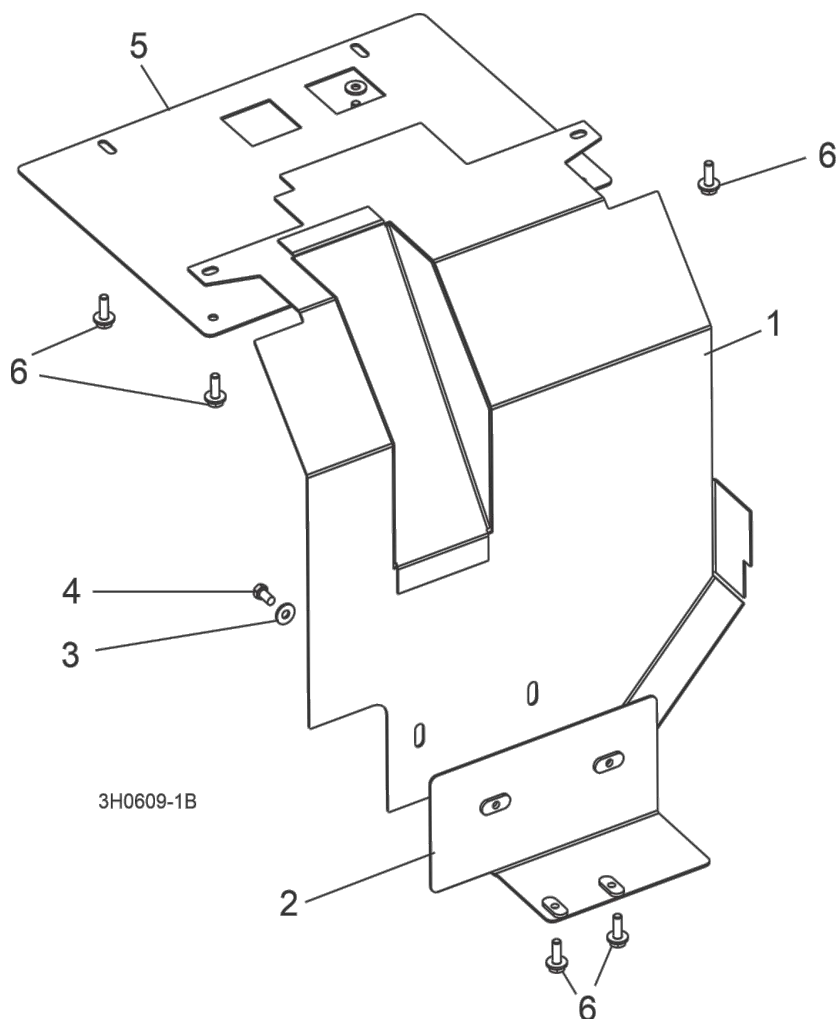

REF	PART #	DESCRIPTION	COMMENTS	QTY.
1	015656	GUARD WELDMENT, AUTOMATIC CLUTCH		1
2	015678	MOUNT WELDMENT, CLUTCH GUARD		1
3	F05011-11	WASHER, 1/4" SAE FLAT		2
4	F05005-15	BOLT, 1/4-20 X 1/2" HEX HEAD		2
5	016089	PLATE, LOWER BELT AUXILIARY GUARD	Auxiliary plate required for Non-Super models without board return mechanism.	1
6	F05005-134	BOLT, 1/4-20 X 3/4" HEX HEAD WITH CONICAL WASHER		6

SECTION 5 ELECTRICAL INFORMATION

5.1 Electrical Components

Component	Manufacturer Part No.	Manufacturer	Wood-Mizer Part No.	Description
C1	024163	Wood-Mizer	024163 ¹	Capacitor Assembly, 1000uF with 1/4" Ring Terminals
CB9	1600-037-030-009	Mech. Prod.	024246	Breaker, 30A Manual Reset Panel Mount
D6	024629	Wood-Mizer	024629	Diode Assy, Autoclutch
M5	S.I. 2917-A	Leeson ²	016021	Motor, 12V 1/3HP External Brush
MOD1	052791	Wood-Mizer	052791 ¹	Module Assembly, Autoclutch Mosfet Upgrade
S5	CH-55015	Indy Wire	051346 ³	Switch, On/On Toggle SPDT
S6, S7	024627	Wood-Mizer	024627	Sensor Assembly, Proximity Magnetic
WA1	061052	Wood-Mizer	061052	Wire Assembly, Autoclutch Mosfet Gate Diode

¹ Capacitor Assembly 024163 added and Mosfet Module 024168 modified to protect against inductive voltage spikes (Rev A.09). Mosfet Upgrade Kit 052791 includes upgraded Mosfet Module and Capacitor Assembly 024163.

² Replaces Owosso motor #PV-28147Q originally supplied prior to Rev. A.04 (12/00).

³ 051346 On/On Toggle Switch replaces 015665 On/Off/On Toggle Switch supplied before 8/03. Center OFF position not required for Autoclutch operation.

5.2 Electrical Diagrams

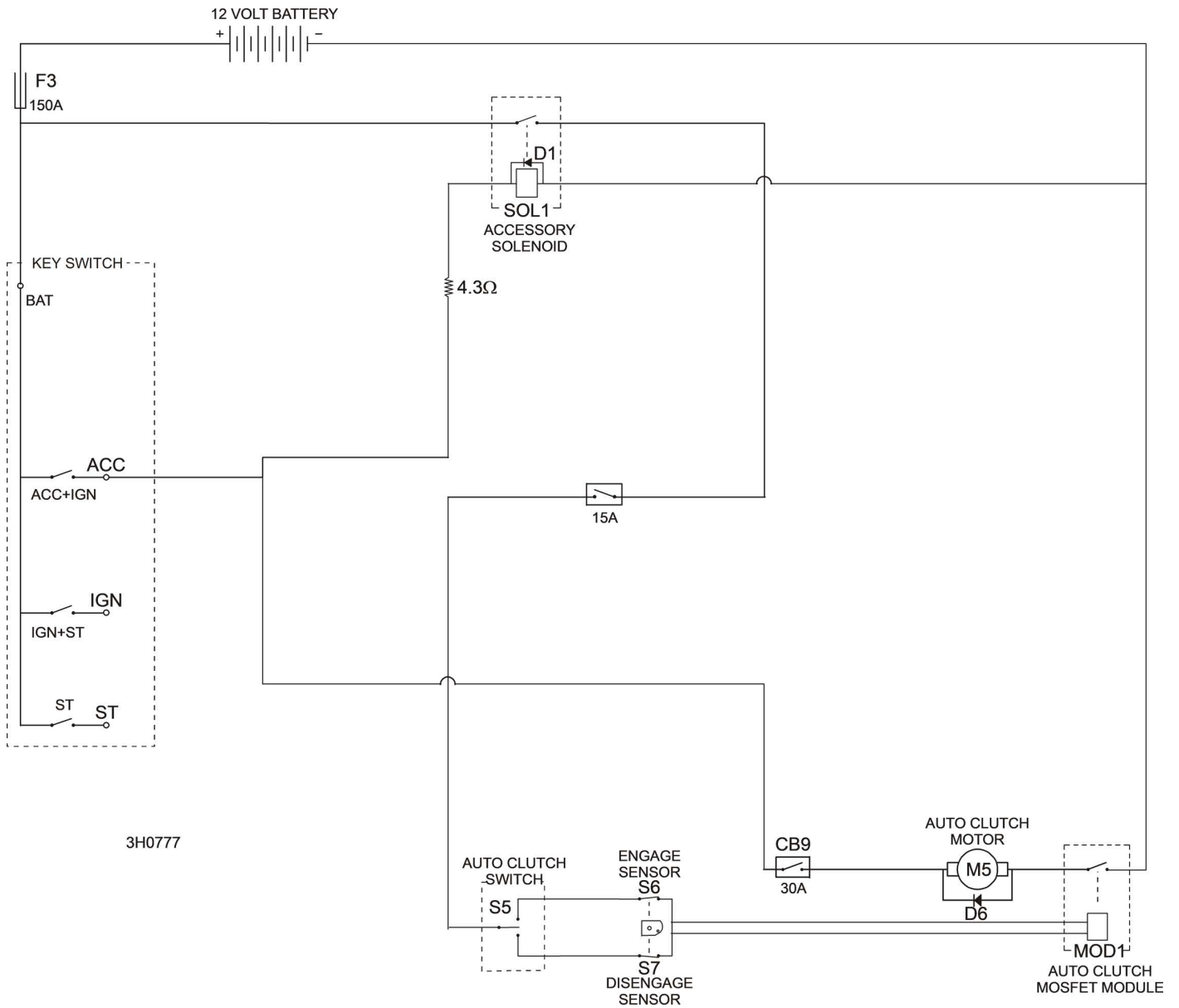

FIG. 5-1 AUTOCLUTCH SYMBOL DIAGRAM (NON-SUPER SAWMILL).

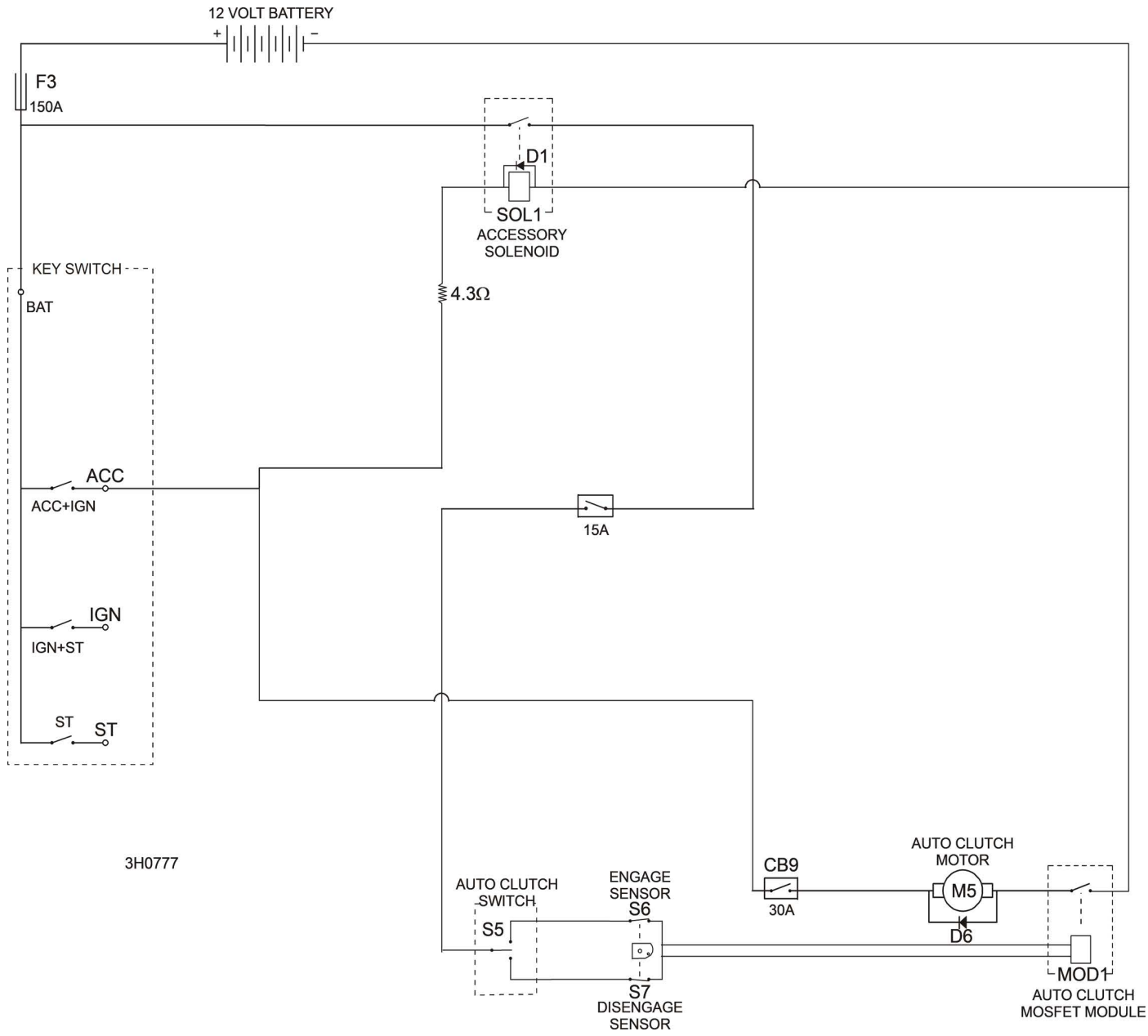

FIG. 5-2 AUTOCLUTCH SYMBOL DIAGRAM (SUPER SAWMILL).

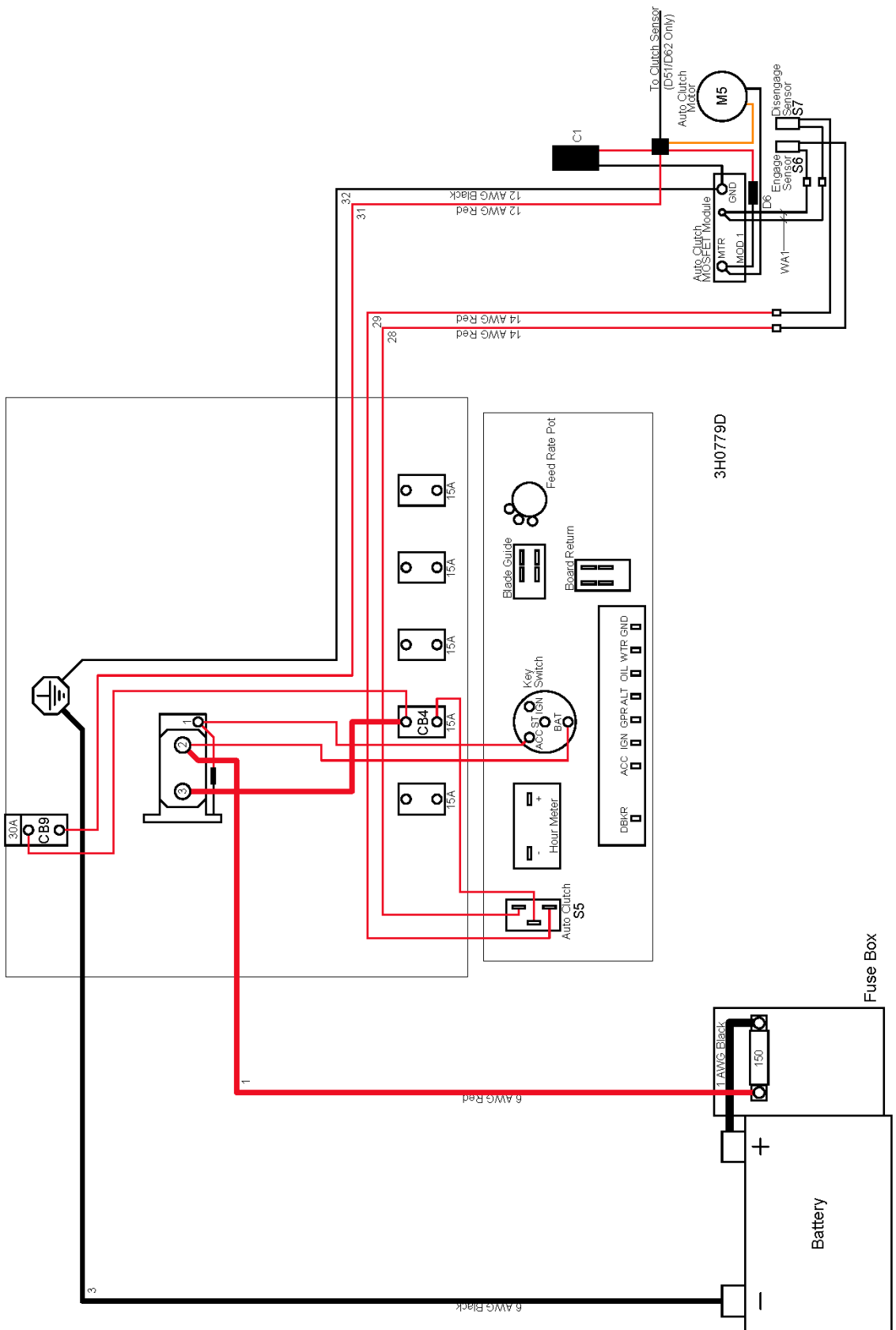

FIG. 5-4 AUTOCLUTCH WIRING DIAGRAM (SUPER)