

APPENDIX A G38 ELECTRICAL INFORMATION

LX250

Rev. A1.00+

[graphics/sawmill_LX/LX250/LX25022]

Table of contents

WM_TableOfContents

Page	Page type	Page description	Date	Edited by
0A1	Table of contents	Table of contents	7/12/2019	TEM
0B1	Overview	Revision History	7/12/2019	TEM
1	Schematic multi-line	Control 1	7/12/2019	TEM
2	Schematic multi-line	Control 2	7/12/2019	TEM
C1	Parts list	Parts list	7/12/2019	TEM
D1	Terminal line-up diagram	Terminal line-up diagram X1	7/12/2019	TEM

Revision History

Date	Revision	Revision Record	Drawn By	Checked By
07/12/19	A1.00	Initial Release	TEM	MCN

		Wood-Mizer®	
Project Description: LX250G38			
Revision:	A1.00	Pg Desc: Revision History	
Mounting Location: +		Type: Overview	
Prev. pg: 0A1	Page: 0B1	Next pg: 1	Total Pgs: 6

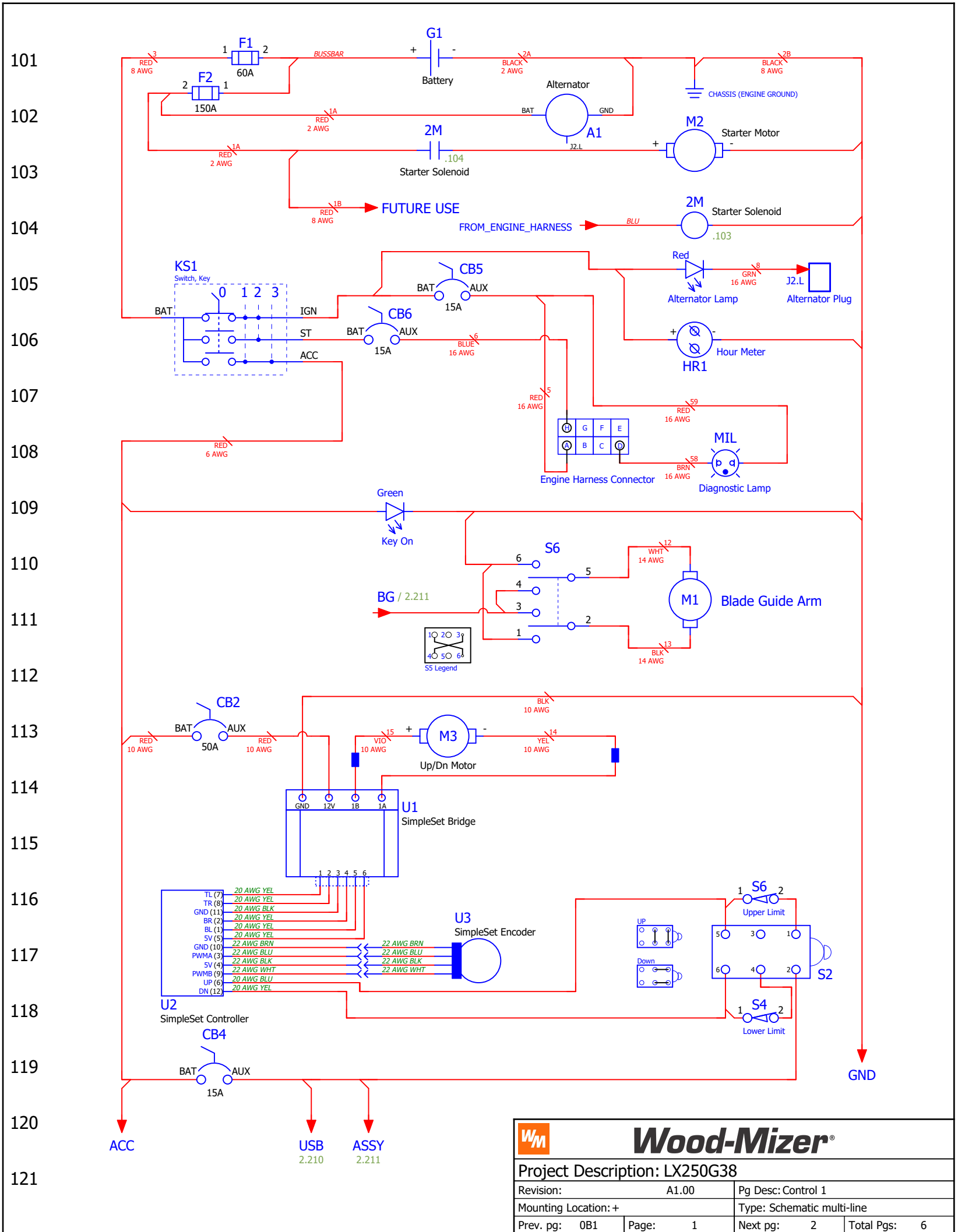

		Wood-Mizer®	
		Project Description: LX250G38	
Revision:	A1.00	Pg Desc: Control 1	
Mounting Location:	+	Type: Schematic multi-line	
Prev. pg:	0B1	Page:	1
		Next pg:	2
		Total Pgs:	6

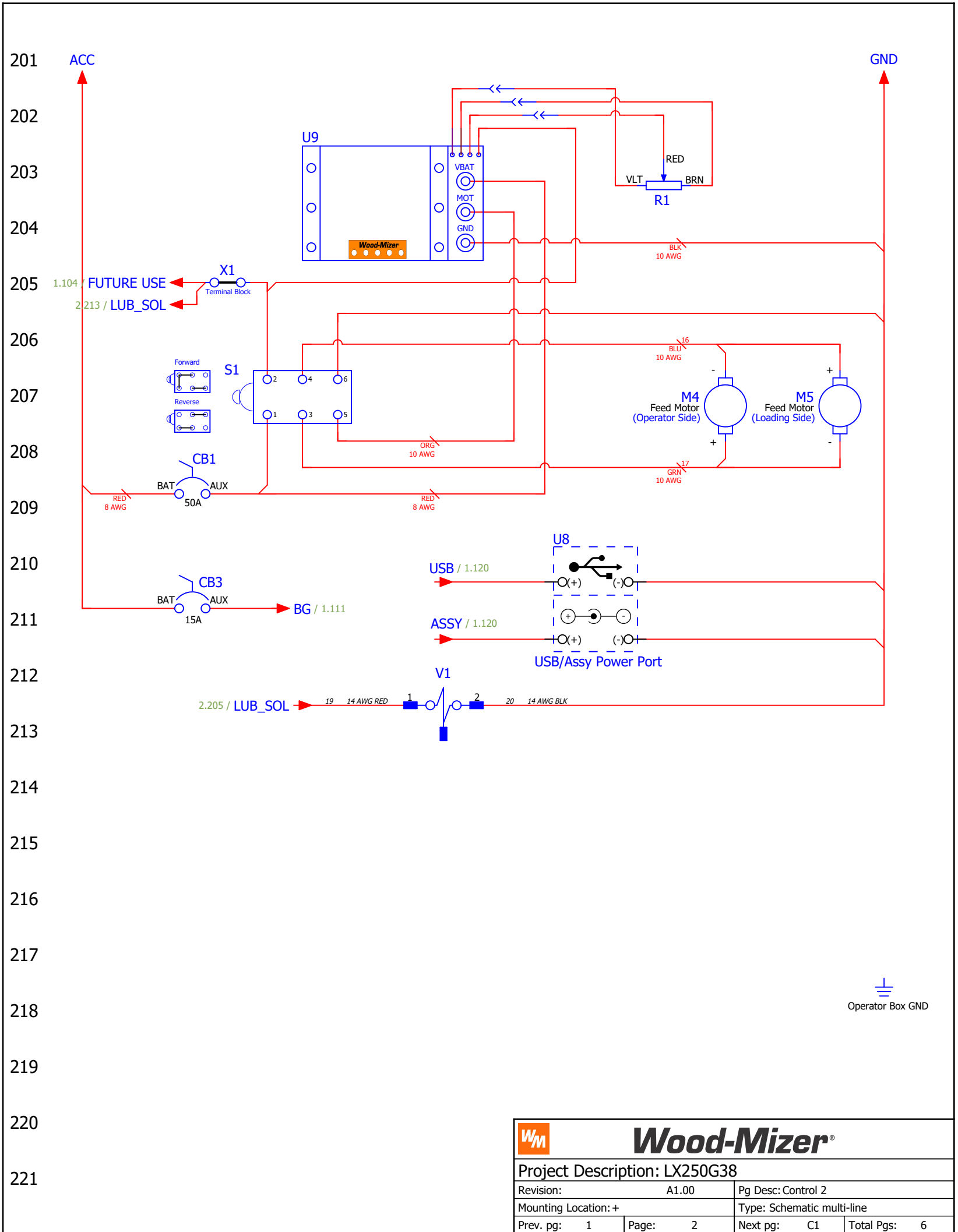

		Wood-Mizer®	
Project Description: LX250G38			
Revision:	A1.00	Pg Desc: Control 2	
Mounting Location:	+	Type: Schematic multi-line	
Prev. pg:	1	Page:	2
		Next pg:	C1
		Total Pgs:	6

Device Tag/Parts List

WM_PARTS_LIST-Manual

Device tag	Function	Wood-Mizer Part Number	Wood-Mizer Description	Qty.	X-Ref
A1	Alternator	050287-1	Alternator, 105A	1	1.102
CB1	P/F Motor breaker	051981	Circuit Breaker, 40A	1	2.209
CB3	Key Switch ST Terminal Breaker	E20430	Breaker, 15A Manual Reset	1	2.211
CB5	Key Switch IGN Terminal Breaker	E20430	Breaker, 15A Manual Reset	1	1.105
CB6	Key Switch ST Terminal Breaker	E20430	Breaker, 15A Manual Reset	1	1.106
F1	Battery Fuse	052370-060	MEGA Fuse 60A	1	1.101
F2	Starter Fuse	052370-150	MEGA Fuse 150A	1	1.102
G1	Battery	079462	Battery, 12V 8A24M AGM	1	1.101
HR1	Hour Meter	015401	Digital Meter, Hour Rect Mount w/Gasket	1	1.106
KS1	Key Switch	P04350	Switch, key	1	1.107
M1	Debarker In/Out Motor	079223	Motor Assy, 1/30HP 12V Gear w/ Deutsch	1	1.111
M4	Feed Motor	006747	0.50 HP DC Motor	1	2.207
M5	=	006747	0.50 HP DC Motor	1	2.207
R1	Feed Rate Switch (Potentiometer)	024450	Pot Assy, Feed Rate Control Sawmill	1	2.203
S1	Forward/Reverse Drum Switch	E20439	Drum Switch, P/F	1	2.207
S2	Up/Down Drum Switch	E20440	Drum Switch, U/D	1	1.117
S6	Blade Guide Arm Switch	024200	Switch, DPDT Toggle 21A Rev Mom Spade	1	1.112
U1	SimpleSet H-Bridge Assembly	053373	Bridge, SS	1	1.115
U2	SimpleSet Controller	053774	Controller, SimpleSet	1	1.117
U3	SimpleSet Encoder Assembly	074021	Encoder Assy, SimpleSet	1	1.117
U8	USB/Assy Power Port	011274	USB/ASSY Port	1	2.210
U9	Forward Feed Control Module	073547.	Module, Consolidated P/F	1	2.204

			<h1>Wood-Mizer®</h1>	
Project Description: LX250G38				
Revision: A1.00		Pg Desc: Parts list		
Mounting Location: +		Type: Parts list		
Prev. pg: 2	Page: C1	Next pg: D1	Total Pgs: 6	

Terminal line-up diagram

Terminal strip X1								
Terminal				Jumper		End Plate	Remark	Terminal X-Ref
Ref. Des.	Level	P/N	Description	Diagram	P/N	P/N		
		052293	Junction Block, 3-Position Wire Clamp	•				2.05
				•				

		Wood-Mizer®	
Project Description: LX250G38			
Revision:	A1.00	Pg Desc: Terminal line-up diagram X1	
Mounting Location: +		Type: Terminal line-up diagram	
Prev. pg: C1	Page: D1	Next pg:	Total Pgs: 6