

APPENDIX A E15 ELECTRICAL INFORMATION

LX250

Rev. A1.00+

[graphics/sawmill_LX/LX250/LX25021]

Revision History

Date	Revision	Revision Record	Drawn By	Checked By
07/10/19	A1.00	Initial Release	TEM	MCN

		Wood-Mizer®	
Project Description: LX250E15			
Revision:	A1.00	Pg Desc: Revision History	
Mounting Location: +		Type: Overview	
Prev. pg: 0A1	Page: 0B1	Next pg: 1	Total Pgs: 6

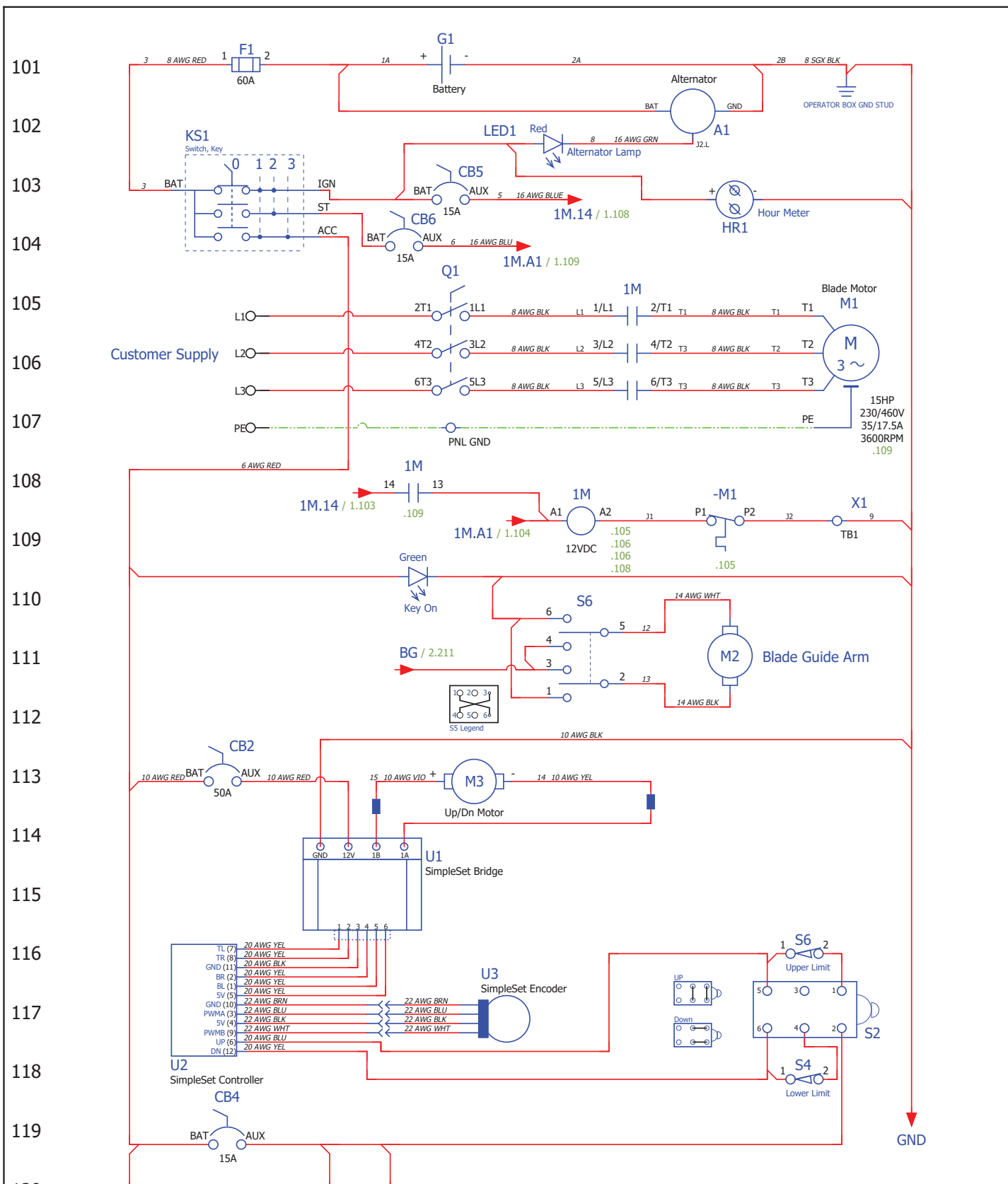

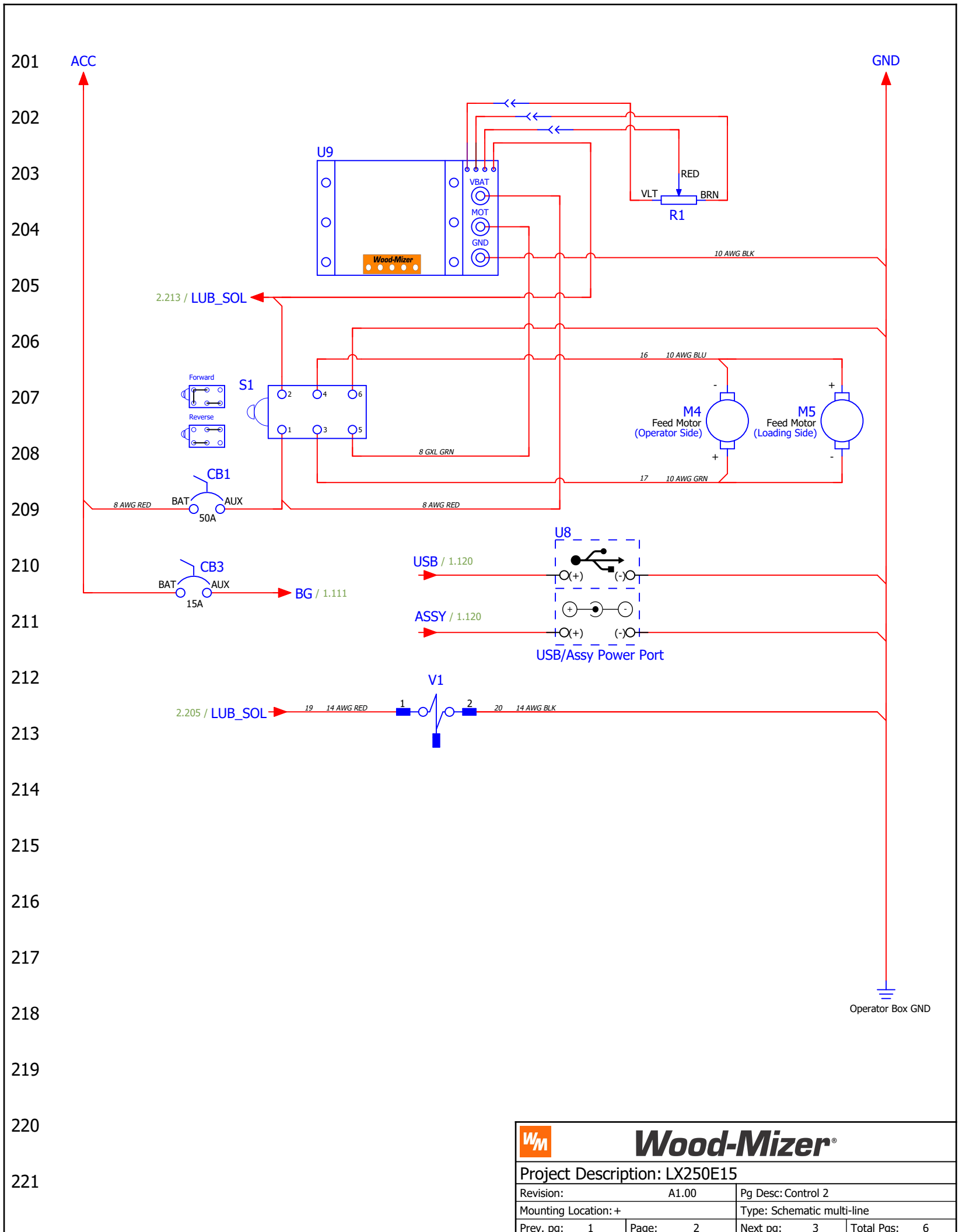



		Wood-Mizer®	
Project Description: LX250E15			
Revision:	A1.00	Pg Desc: Control 2	
Mounting Location:	+	Type: Schematic multi-line	
Prev. pg:	1	Page:	2
		Next pg:	3
		Total Pgs:	6

Device Tag/Parts List

WM_PARTS_LIST-Manual

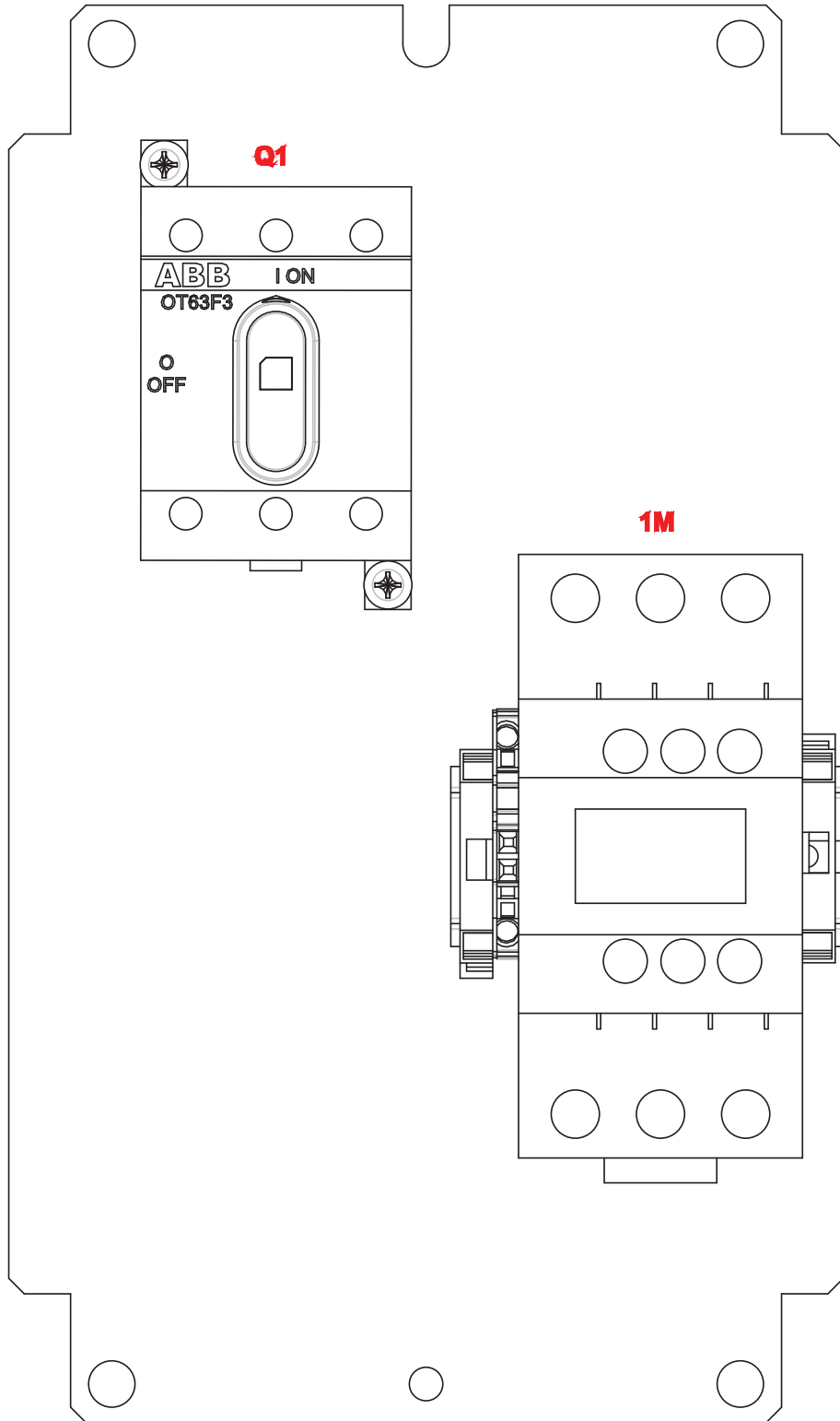
Device tag	Function	Wood-Mizer Part Number	Wood-Mizer Description	Qty.	X-Ref
A1	Alternator	050287	Alternator, 105A	1	1.102
CB1	P/F Motor breaker	051981	Circuit Breaker, 40A	1	2.209
CB3	Key Switch ST Terminal Breaker	E20430	Breaker, 15A Manual Reset	1	2.211
CB5	Key Switch IGN Terminal Breaker	E20430	Breaker, 15A Manual Reset	1	1.103
CB6	Key Switch ST Terminal Breaker	E20430	Breaker, 15A Manual Reset	1	1.104
F1	Battery Fuse	052370-060	MEGA Fuse 60A	1	1.101
G1	Battery	079462	Battery, 12V 8A24M AGM	1	1.101
HR1	Hour Meter	015401	Digital Meter, Hour Rect Mount w/Gasket	1	1.103
KS1	Key Switch	P04350	Switch, key	1	1.104
LED1	Board, LED Circuit	015416	PCB Assy, LED Gas/Elec Sawmill 1997	1	1.102
M1	Blade Motor	074780	Motor, 15HP 3520RPM Leeson Wattsaver	1	1.105
M2	Debarker In/Out Motor	079223	Motor Assy, 1/30HP 12V Gear w/ Deutsch	1	1.111
M4	Feed Motor	006747	0.50 HP DC Motor	1	2.207
M5	=	006747	0.50 HP DC Motor	1	2.207
1M	Blade Motor Contactor	069521	Contactor, 65A 3P 12VDC Coil D-A Series	1	1.109
Q1	Blade Motor Disconnect	050881-1	Disconnect, 63A 600V 3P 6mm Shaft	1	1.105
R1	Feed Rate Switch (Potentiometer)	024450	Pot Assy, Feed Rate Control Sawmill	1	2.203
S1	Forward/Reverse Drum Switch	E20439	Drum Switch, P/F	1	2.207
S2	Up/Down Drum Switch	E20440	Drum Switch, U/D	1	1.117
S6	Blade Guide Arm Switch	024200	Switch, DPDT Toggle 21A Rev Mom Spade	1	1.112
U1	SimpleSet H-Bridge Assembly	053373	Bridge, SS	1	1.115
U2	SimpleSet Controller	053774	Controller, SimpleSet	1	1.117
U3	SimpleSet Encoder Assembly	074021	Encoder Assy, SimpleSet	1	1.117
U8	USB/Assy Power Port	011274	USB/ASSY Port	1	2.210
U9	Forward Feed Control Module	073547.	Module, Consolidated P/F	1	2.204



		Wood-Mizer®	
Project Description: LX250E15			
Revision:	A1.00	Pg Desc: Motor Starter Control	
Mounting Location: +		Type: Panel layout	
Prev. pg:	C1	Page:	F1
		Next pg:	Total Pgs: 6