

# Wood-Mizer<sup>®</sup> Sawmill

Safety, Setup, Operation  
& Maintenance Manual

---

LX250

rev. A2.04

---

**Safety is our #1 concern!**

*Form #2370*



**WARNING! Read and understand this manual before using this machine.**

## California

### Proposition 65 Warning



**WARNING:** Breathing gas/diesel engine exhaust exposes you to chemicals known to the State of California to cause cancer and birth defects or other reproductive harm.

Always start and operate the engine in a well-ventilated area.  
If in an enclosed area, vent the exhaust to the outside.  
Do not modify or tamper with the exhaust system.  
Do not idle the engine except as necessary.

For more information go to [www.P65warnings.ca.gov](http://www.P65warnings.ca.gov).



**WARNING:** Drilling, sawing, sanding or machining wood products can expose you to wood dust, a substance known to the State of California to cause cancer. Avoid inhaling wood dust or use a dust mask or other safeguards for personal protection.

For more information go to [www.P65Warnings.ca.gov/wood](http://www.P65Warnings.ca.gov/wood).

### Active Patents assigned to Wood-Mizer, LLC

Wood-Mizer, LLC has received patents that protect our inventions which are a result of a dedication to research, innovation, development, and design. Learn more at: [woodmizer.com/patents](http://woodmizer.com/patents)

### ©2024 Wood-Mizer LLC

Printed in the United States of America, all rights reserved. No part of this manual may be reproduced in any form by any photographic, electronic, mechanical or other means or used in any information storage and retrieval system without written permission from

**Wood-Mizer, LLC**  
**8180 West 10th Street**  
**Indianapolis, Indiana 46214**

**SECTION 1 INTRODUCTION**

1.1 About This Manual ..... 1-1  
 1.2 Getting Service..... 1-1  
 1.3 Specifications ..... 1-1  
 1.4 Specifications ..... 1-2  
     *LX250 Dimensions* ..... 1-3

**SECTION 2 GENERAL SAFETY**

2.1 Safety Symbols ..... 2-1  
 2.2 Safety Instructions..... 2-1  
 2.3 Electrical Lockout Procedures ..... 2-3

**SECTION 3 SAWMILL ASSEMBLY**

3.1 Tools required ..... 3-1  
 3.2 Uncrating the mill ..... 3-1  
 3.3 Assemble the bed ..... 3-5  
 3.4 End Stop Assemblies ..... 3-9  
 3.5 Adjusting/leveling the Bed..... 3-9  
 3.6 Saw Carriage Assembly ..... 3-10  
 3.7 Feed Drive Assembly ..... 3-11

**SECTION 4 SAWMILL SETUP**

4.1 Installing the Blade ..... 4-1  
 4.2 Tensioning The Blade ..... 4-2  
 4.3 Tracking The Blade..... 4-2  
 4.4 Sawhead Tilt ..... 4-3  
 4.5 Sawblade ..... 4-3  
     *Blade Guide Vertical Tilt Alignment*..... 4-3  
     *Blade Guide Flange Spacing*..... 4-4  
 4.6 Starting The Engine ..... 4-5

**SECTION 5 SAWMILL OPERATION**

5.1 Manual Power Feed ..... 5-1  
 5.2 Manual Up/Down Operation..... 5-3  
 5.3 Up/Down (Simple Set Operation)..... 5-3  
     *Changing the Default Setup* ..... 5-4  
     *Operation* ..... 5-5  
 5.4 Loading, Turning, & Clamping Logs..... 5-6  
 5.5 Blade Guide Arm Operation ..... 5-8  
 5.6 Cutting The Log ..... 5-8  
 5.7 Edging ..... 5-10  
 5.8 Blade Height Scale..... 5-10  
 5.9 Water Lube Operation..... 5-12  
 5.10 Transporting the Sawmill..... 5-13

**SECTION 6 MAINTENANCE**

6.1 *Wear Life* ..... 6-1  
 6.2 Blade Guides ..... 6-1

# Table of Contents

# Section-Page

6.3	Changing The Blade .....	6-2
6.4	Add Oil to Tensioner Cylinder .....	6-3
6.5	Sawdust Removal .....	6-5
6.6	Mast Track, Wipers, & Scrapers .....	6-5
6.7	Vertical Mast Rails .....	6-5
6.8	Miscellaneous .....	6-6
6.9	Drive Belt Adjustment.....	6-6
6.10	Up/Down System.....	6-7
6.11	Charging The Battery .....	6-8

## SECTION 7 TROUBLESHOOTING GUIDE

7.1	Sawing Problems.....	7-1
8.2	Simple Set Troubleshooting .....	8-1
	<i>Error Messages</i> .....	8-1
	<i>Diagnostic Lights</i> .....	8-1
	<i>Simple Set Up/Down Gear Settings Adjustment</i> .....	8-2
	<i>Simple Set PID Settings</i> .....	8-3

## SECTION 8 SAWMILL ALIGNMENT

9.1	Routine Alignment Procedure .....	9-1
	<i>Prepare the sawmill for alignment</i> .....	9-1
	<i>Saw Head Tilt</i> .....	9-1
	<i>Blade Guide Arm Alignment</i> .....	9-2
	<i>Blade Guide Vertical Tilt Alignment</i> .....	9-4
	<i>Blade Guide Horizontal Tilt Adjustment</i> .....	9-5
	<i>Blade Guide Flange Spacing</i> .....	9-5
	<i>Blade Height Scale Adjustment</i> .....	9-6
9.2	Complete Alignment Procedure .....	9-7
	<i>Frame Setup</i> .....	9-7
	<i>Complete Blade Replacement</i> .....	9-7
	<i>Blade Wheel Alignment</i> .....	9-7
	<i>Blade Guide Re-installation</i> .....	9-9
	<i>Saw Head Tilt</i> .....	9-10
	<i>Blade Guide Arm Alignment</i> .....	9-10
	<i>Blade Guide Deflection</i> .....	9-10
	<i>Blade Guide Vertical Tilt Alignment</i> .....	9-10
	<i>Blade Guide Horizontal Tilt Alignment</i> .....	9-10
	<i>Blade Guide Flange Spacing</i> .....	9-10
	<i>Blade Height Scale Adjustment</i> .....	9-10

## INDEX

## I



**Wood-Mizer® LLC**  
**Limited Product Warranty**



Wood-Mizer LLC (“Warrantor”), an Indiana corporation with its principal place of business at 8180 West Tenth Street, Indianapolis, IN 46214-2400 USA, warrants to the purchaser (“Purchaser”) that for the time periods specifically stated herein and subject to the terms, conditions and limitations stated herein, the equipment manufactured by the Warrantor will be free from defects in material and workmanship attributable to Warrantor so long as, during the warranty periods stated herein, the equipment is installed, operated and maintained in accordance with the instructions provided by Warrantor.

PRODUCT	MODEL CLASS	LENGTH OF WARRANTY		EFFECTIVE DATE
		USA & CANADA	NON USA & CANADA	
Portable Sawmills, Resaws, Edgers	LT, LX, HR, EG	Two years	One year	Date of purchase
Portable Sawmills with Chassis	LT28, LT35, LT40, LT50, LT70, LX450	Two years, excluding the chassis, which chassis shall have a five year warranty	One year	
Industrial Sawmills, Resaws, Edgers	WM, HR, EG, TVS, SVS	One year	One year	Date of purchase or date of installation / training (if applicable), whichever occurs first, not to exceed 6 months from date of purchase
TITAN Industrial	WB, TV, HR, EG, EA, MR	One year	One year	
Material Handling	TWC, IC, TD, LD, GC, CR, CB, CC	One year	One year	
Blade Maintenance Equipment	BMS, BMT, BMST	One year	One year	Date of purchase
Options and Accessories	Various	One year*	One year*	
Moulders, Extractors, Kilns	MP, MD, KS, KD	One year	One year	
Slab Flatteners	MB	Two years	One year	
Pallet Equipment	PD, PC	One year	One year	
Log Splitters	FS	One year	One year	
Replacement Parts	Various	90 days	90 days	

\* Warranty on Options will match the warranty on the primary equipment when purchased on same invoice.

**Exclusions from 90 Day, Limited One Year and Two Year Warranty**

Warrantor shall have no responsibility under this warranty for any wear components, including, but not limited to: belts, blade guides, blades, electric motor brushes, drum switches, filters, fuses, hoses, bearings (excluding cylindrical drive bearings), bushings, cable carriers, and spark plugs. All wear components are furnished “as is”, without any warranty from Warrantor. This limited warranty does not cover any defects caused by misuse, negligence, alterations, damage due to overload, abnormal conditions, excessive operation, accident, or lack of performance of normal maintenance services.

Several components which are used in the manufacture of the equipment but not manufactured by Warrantor such as cant hooks, power plants, laser sights, batteries, tires, and trailer axles have warranties provided by the original equipment manufacturer (written copies available upon request). Warrantor does not separately warrant such items. Components or equipment manufactured by third parties are not covered by this warranty. Warrantor, however, will provide reasonable assistance to the Purchaser to make claims against any warranties applicable to such component parts as provided by such original equipment manufacturers. Components or equipment manufactured by third parties are not covered by this Warranty.

**Five Year Limited Chassis Warranty**

The limited five year chassis warranty described above, DOES NOT extend to (a) any damage stemming from accident, improper towing, overload, abuse, misuse, abnormal conditions, negligence, excessive operation, or lack of maintenance, (b) rust caused by exposure to corrosive atmospheric conditions, or (c) the sawmill head, carriage, axle, brakes, or any hydraulic or electrical components attached to the chassis.

**Warrantor’s Obligations as To Defects**

In the event that the equipment fails to perform due to defective materials or workmanship attributable to Warrantor under normal use and service within the established warranty period, Purchaser’s sole and exclusive remedy and Warrantor’s sole liability shall be to replace or repair, in Warrantor’s sole and subjective discretion, any defective part at Warrantor’s principal place of business without cost to the Purchaser if such defect exists. The determination of whether a product is defective shall be made by Warrantor in Warrantor’s sole and subjective discretion. The Purchaser must notify Warrantor prior to shipping any defective part. Warrantor, at its sole discretion, may cover expenses incurred in shipping the defective part to Warrantor for evaluation; provided, however, that Warrantor will not be responsible for labor, travel time, mileage, removal, installation or incidental or consequential damages. However, any part in excess of 140 pounds must be returned by the Purchaser, to the Warrantor’s nearest authorized facility at the Purchaser’s expense, if return is requested by Warrantor. Warrantor shall have a reasonable time within which to replace or repair the defective part. If Warrantor determines that the product is not defective under the terms of this warranty in Warrantor’s sole and subjective discretion, then Purchaser shall be responsible for any expenses incurred by Warrantor in returning the equipment to the Purchaser.

**Limitations and Disclaimers of Other Warranties**

EXCEPT FOR THE EXPRESS WARRANTY PROVISIONS STATED ABOVE, WARRANTOR DISCLAIMS ALL WARRANTIES, EXPRESS AND/OR IMPLIED, INCLUDING WITHOUT LIMITATION, THE IMPLIED WARRANTIES OF MERCHANTABILITY, AND FITNESS FOR A PARTICULAR PURPOSE, NONINFRINGEMENT AND TITLE. No representation or other affirmation of fact by representatives of Warrantor, whether verbal or in writing, including photographs, brochures, samples, models, or other sales aids, shall constitute a warranty or other basis for any legal action against Warrantor. There are no other representations, promises, agreements, covenants, warranties, guarantees, stipulations or conditions, express or implied, by Warrantor except as expressly set forth herein. THE ORIGINAL PURCHASER AND ANY INTENDED USER OR BENEFICIARY OF THIS EQUIPMENT, SHALL NOT BE ENTITLED TO RECOVER ANY INDIRECT, SPECIAL, PUNITIVE, EXEMPLARY, CONSEQUENTIAL, SPECIAL, OR INCIDENTAL DAMAGES OR LOSSES, INCLUDING BUT NOT LIMITED TO, DAMAGES OF LOST PRODUCTION, LOST REVENUE, LOST PRODUCT, LOST PROFITS, LOST BUSINESS, LOSS OF USE, LOSS OF GOODWILL, OR BUSINESS INTERRUPTION, FROM WARRANTOR FOR ANY REASON WHATSOEVER INCLUDING WITHOUT LIMITATION WARRANTY OR DEFECT IN THE PRODUCT REGARDLESS OF THE SOLE, JOINT AND/OR CONCURRENT NEGLIGENCE, BREACH OF CONTRACT, BREACH OF WARRANTY, STRICT LIABILITY IN TORT OR STATUTORY CLAIMS OR OTHER LEGAL FAULT OR RESPONSIBILITY OF EITHER WARRANTOR OR PURCHASER OR ITS EMPLOYEES OR AGENTS. Warrantor does not warrant that its equipment meets or complies with the requirements of any particular safety code or governmental requirements.

Defective items replaced under the terms of this warranty become the property of Warrantor.

**Design Changes**

Warrantor reserves the right to change the design of its products from time to time without notice and without obligation to make corresponding changes in or to its products previously manufactured.

**Rights of Purchasers**

The validity and effect of this limited warranty as well as its interpretation, operation and effect, shall be determined exclusively by the principles of law and equity of the State of Indiana, USA. This limited warranty gives Purchaser specific legal rights. Purchaser may also have other rights, which may vary from state to state. Some states may not allow limitations as to the duration of implied warranties or to the exclusion or limitation of incidental or consequential damages, so some of the limitations and exclusions detailed set forth above may not apply. In the event that any one or more of the provisions of this warranty shall be or become invalid, illegal or unenforceable in any respect, the validity, legality and enforceability of the remaining provisions of this warranty shall not be affected thereby.

**Interpretations**

This Warranty constitutes the entire warranty agreement between Warrantor and Purchaser and supersedes any prior understandings or agreements pertaining to the same subject matter. This warranty cannot be amended except in writing which refers to this warranty which is signed by both Warrantor and Purchaser.

## SECTION 1 INTRODUCTION

### 1.1 About This Manual

This manual replaces any previous information received on your Wood-Mizer® equipment.

The information and instructions in this manual do not amend or extend the limited warranties for the equipment given at the time of purchase.

### 1.2 Getting Service

For contact information, sales, service, parts, and additional manuals, sign into your account on <https://woodmizer.com>, or call inside the USA: 1-800-553-0182 or from outside the USA: 317-271-1542

### 1.3 Specifications

Equipment specification are included in the Online Manuals, which are found at <https://apps.woodmizer.com/Manuals/Manuals.aspx?parent=0>.

## 1.4 Specifications

---

### Model: LX250 Rev. A1.00+

---

#### Dimensions:

Length:	18'-2.5"
Bed width:	5'-3.25"
Unit width:	9'-2.12"
Height (Ground To Mast):	8'-6.67"
Height (Max Head Position):	9'-9.75"
Blade:	.042 x 1¼ x 215; 10°

---

#### Weights (Actual/Estimated):

Basic Unit :	2960 lbs
Shipping weight:	3340 lbs

---

#### Log Capacity:

Length:	156" (13')
Bed extension:	60" (5')
Log diameter:	55"
Cut diameter:	54.5"

---

#### Engine:

**G38**

Manufacturer:	Kohler
Fuel:	Gas
Horsepower Rating:	38
Weight:	151
Idle Speed:	1500 RPM
High Throttle Speed (No Load):	3600 RPM
Cooling System:	Air
Drive Shaft O.D.:	1 1/8"
Drive Pulley O.D.:	5.6"
Drive Belt:	2/3VFL900
Blade Braking:	5 Seconds
Oil Capacity w/Filter:	2.1-2.7 qts.
Battery:	12V 524/26A

---

#### Rates:

Hourly Production (Average range w/experienced operators/average size logs):	up to 125 bdf.
--	----------------

---



**LX250 Dimensions**

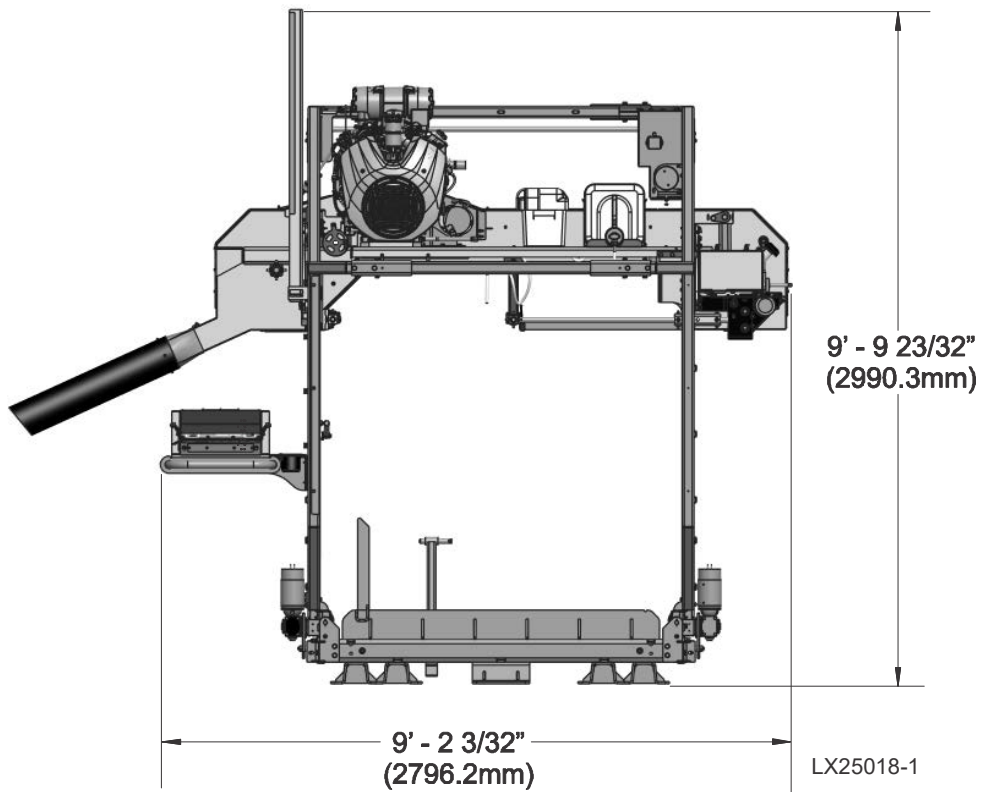
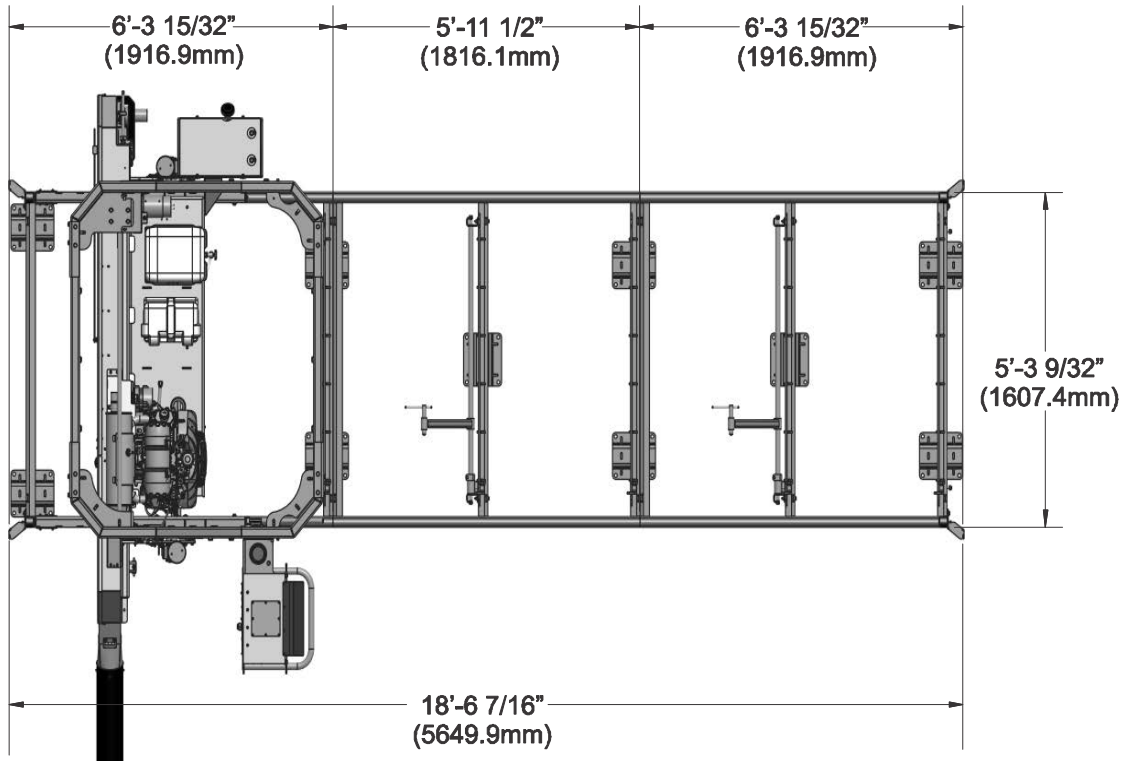

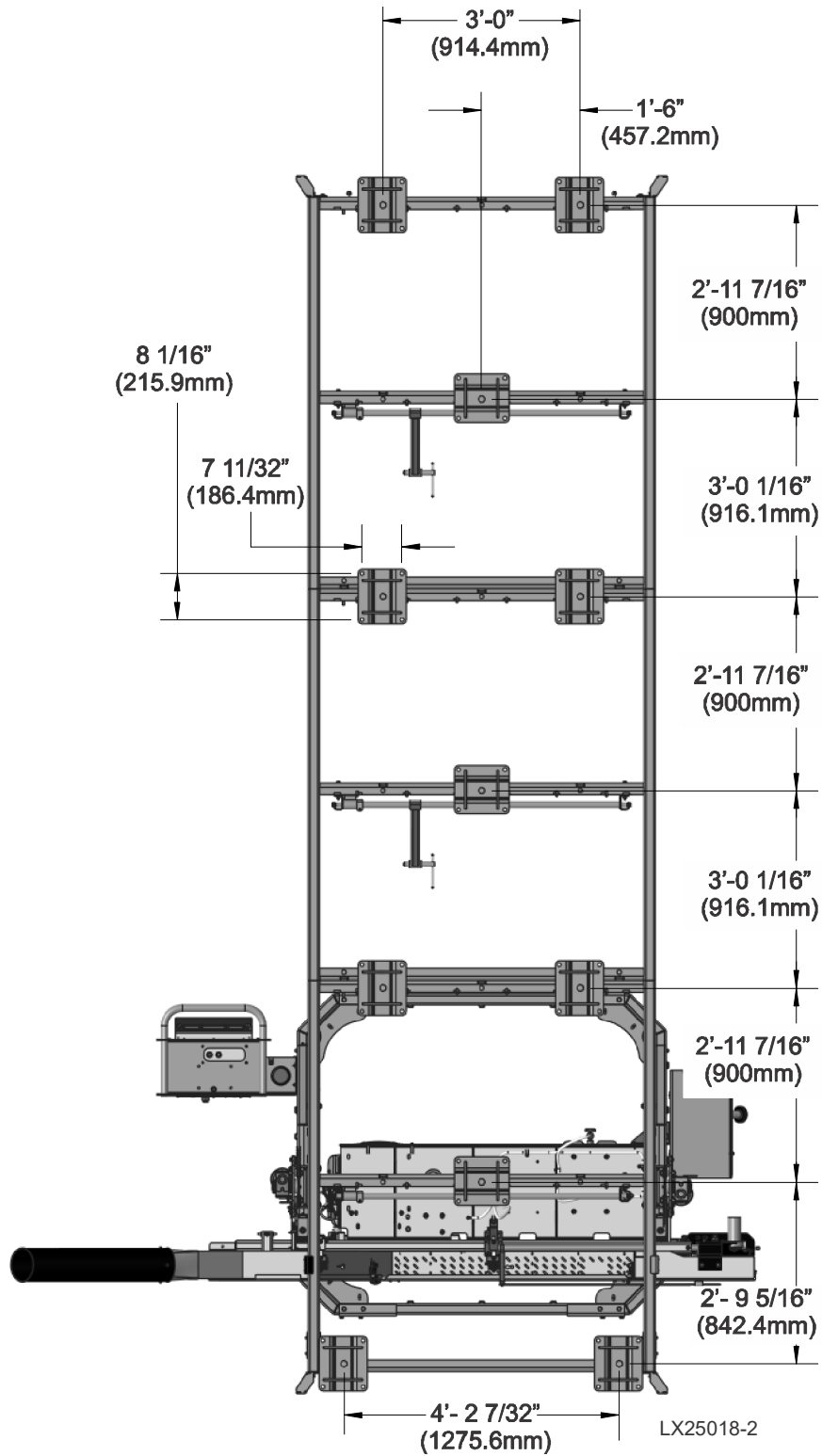

## SECTION 2 GENERAL SAFETY

### 2.1 Safety Symbols

The following symbols and signal words call your attention to instructions concerning your personal safety. Be sure to observe and follow these instructions.



**DANGER!** indicates an imminently hazardous situation which, if not avoided, will result in serious injury or death.



**WARNING!** suggests a potentially hazardous situation which, if not avoided, could result in serious injury or death.



**CAUTION!** refers to potentially hazardous situations which, if not avoided, may result in minor or moderate injury or damage to equipment.

**NOTICE** indicates vital information.

### 2.2 Safety Instructions

#### OWNER/OPERATOR'S RESPONSIBILITY

The procedures listed in this manual may not include all ANSI, OSHA, or locally required safety procedures. **It is the owner/operator's responsibility and not Wood-Mizer LLC to ensure all operators are properly trained and informed of all safety protocols.** Owner/Operators are responsible for following all safety procedures when operating and performing maintenance to the equipment.

#### OBSERVE ALL SAFETY INSTRUCTIONS

**NOTICE** Read the entire Operator's Manual before operating this equipment.

Note all safety warnings throughout this manual and those posted on the machine.

Be able to access this manual at all times while operating this equipment.

Read additional manufacturer's manuals and observe their applicable safety instructions.

Only persons who have read and understood the entire operator's manual should operate this equipment.

This equipment is not intended for use by or around children.

**It is the owner/operator's responsibility to comply with all applicable federal, state, and local laws, rules, and regulations regarding the ownership, operation, and transporting your equipment.**

Operators should become thoroughly familiar with and comply with these applicable laws for operating and transporting equipment.



**WARNING!** Clean sawdust from all guards, vents, control boxes, or any area where sawdust may gather **after every shift**. Failure to

do so may result in fire, causing death or serious injury.

#### WEAR SAFETY CLOTHING



**WARNING!** Secure all loose clothing and jewelry before operating the equipment.

Always wear eye, ear, and foot protection when operating or servicing the equipment.

Wear hand protection while servicing the equipment blades.

Wear respiratory protection when sawing woods that require it. (It is up to the sawyer to know which woods require respiratory protection.)

#### HANDLE FUEL/LUBRICANTS SAFELY



**DANGER!** Due to the flammable nature of fuel and oil, never smoke, weld, grind or allow sparks near your engine or storage tanks, especially during times of fueling.

Do not allow fuel to spill on a hot engine during fueling operations or otherwise.



**WARNING!** Store gasoline away from sawdust and other flammable materials.

Do not use flammable fuels or liquids such as diesel fuel. Use **ONLY** water and Wood-Mizer Lube Additive with the water lube accessory.

#### EQUIPMENT SETUP



**DANGER!** Do not operate the equipment without **all** covers and guards in place.



**WARNING!** Set up the equipment on solid, level ground.

Keep all persons out of the area between the frame rails while loading and unloading the equipment.

#### CHECK EQUIPMENT BEFORE OPERATION



**DANGER!** Ensure all guards and covers are in place and secured before operating or towing the equipment.

Use the safety retainer pin and cable to fasten blade housing covers.



**WARNING!** Do not operate the equipment without the bed end retaining brackets properly installed; the saw head may fall from the log bed.

## KEEP PERSONS AWAY

 **DANGER!** Keep all persons out of the path of moving equipment and logs when operating equipment or loading and turning logs.

Ensure the blade is disengaged and all persons are out of the path of the blade before starting the engine or motor.

## KEEP HANDS AWAY

 **DANGER!** Remove power before clearing debris or any other maintenance activity.

Disengage the blade and shut off the equipment engine before changing the blade.

 **WARNING!** Avoid contact with any hot parts (motors).

**Allow the system to cool sufficiently before beginning any service function, including debris removal.**

Avoid contact with sharp edges of the cutting blades.

Stay a safe distance from rotating members (shafts, pulleys, fans, etc.) and ensure loose clothing or long hair does not engage rotating members

Do not spin the blade wheels by hand. Spinning the blade wheels by hand may result in serious injury.

Disengage the clutch/brake mechanism whenever the equipment is not cutting.

Do not adjust the engine drive belt with the engine running.

Keep hands, feet, etc., clear of exiting sawdust chute when operating equipment.

## UP/DOWN SYSTEM SAFETY

 **WARNING!** Secure the saw head with a chain with a minimum of 1900 lbs. working load capacity before adjusting the up/down chain.

Release pressure from the up/down assist prior to performing any service to the assembly. Parts are under tension and may fly apart.

Do not disassemble the pressurized cylinder. Parts are under pressure and may fly apart or damage the cylinder.

## KEEP SAFETY LABELS IN GOOD CONDITION

**NOTICE** Ensure that all safety decals are clean and readable. Replace all damaged safety decals to prevent personal injury or damage to the equipment. Contact your local

distributor, or call your Customer Service Representative to order more decals.

**NOTICE** If replacing a component that has a safety decal affixed to it, ensure the new component also has the safety decal affixed in the same place.

## KEEP MILL AND AREA AROUND MILL CLEAN

 **WARNING!** Maintain a clean and clear path for all necessary movement around the mill and material stacking areas.

Do not allow children in the area of the mill.

## GAS OR DIESEL ENGINE OPERATION

 **DANGER!** Operate your engine/machine only in well ventilated areas.

Do not operate an engine with a fuel or oil leak.

 **WARNING!** Do not operate engine without proper and operational spark arrester/muffler.

## DISPOSE OF WOOD BY-PRODUCTS PROPERLY

**NOTICE** Properly dispose of all wood by-products, including sawdust, chips, and other debris, including operation waste such as oil, filters, etc.

## WORKING WITH BATTERIES

 **DANGER!** Batteries expel explosive gases; keep sparks, flames, burning cigarettes, or other ignition sources away at all times.

 **WARNING!** Always wear safety goggles and a face shield when working near batteries.

Wash hands after handling batteries to remove possible lead, acid, or other contaminants.

Charge the battery in a well ventilated area.

Do not attempt to charge a frozen battery.

 **CAUTION!** Do not overcharge the battery. Overcharging may reduce the overall service life of the battery.

Ensure the battery is fully charged before transporting the equipment. If the battery is not fully charged, excessive vibration could reduce the overall service life of the battery.

**NOTICE** When working with batteries, use extreme care to avoid spilling or splashing electrolyte (dilute sulfuric acid) as it can destroy clothing and burn the skin.

**EMERGENCY TREATMENT FOR CONTACT WITH BATTERY COMPONENTS (LEAD/SULFURIC ACID) per SDS (Safety Data Sheet):**

<b>EYE CONTACT</b>	<b>Sulfuric Acid and Lead:</b> Flush eyes immediately with large amounts of water for at least 15 minutes while lifting lids. Seek immediate medical attention.
<b>SKIN CONTACT</b>	<b>Sulfuric Acid:</b> Flush affected area(s) with large amounts of water using deluge emergency shower, if available, shower for at least 15 minutes. Remove contaminated clothing, including shoes. If symptoms persist, seek medical attention. Wash contaminated clothing before reuse. Discard contaminated shoes. <b>Lead:</b> Wash immediately with soap and water.
<b>INGESTION</b>	<b>Sulfuric Acid:</b> Administer large amounts of water. Do NOT induce vomiting or aspiration into the lungs may occur and can cause permanent injury or death; consult physician.
<b>INHALATION</b>	<b>Sulfuric Acid:</b> Remove to fresh air immediately. If not breathing, give artificial respiration. If breathing is difficult, give oxygen. Consult a physician. <b>Lead:</b> Remove from exposure, gargle, wash nose and lips; consult physician.

**2.3 Electrical Lockout Procedures**

**RULES FOR USING LOCKOUT PROCEDURE**

The equipment shall be locked out to protect against accidental or inadvertent operation when such operation could cause injury to personnel. Do not attempt to operate any switch or valve bearing a lock.

**LOCKOUT PROCEDURES MUST BE USED DURING, BUT NOT LIMITED TO:**

- Changing or adjusting blades
- Unjamming operations
- Cleaning
- Mechanical repair
- Electrical maintenance
- Retrieval of tools/parts from work area
- Activities where guards or electrical panel guard is open or removed

**MAINTENANCE HAZARDS INCLUDE, BUT NOT LIMITED TO:**

- Blade contact
- Pinch points
- Kickbacks
- Missiles (thrown blades/wood chips)
- Electrical

**FAILURE TO LOCKOUT MAY RESULT IN, BUT NOT LIMITED TO:**

- Cut
- Crush

- Blindness
- Puncture
- Electrocutation
- Serious injury and death
- Amputation
- Burn
- Shock

**TO CONTROL MAINTENANCE DANGERS:**

- Lockout procedures must be followed (see **OSHA regulation 1910.147**).
- Never rely on machine stop control for maintenance safety (emergency stops, on/off buttons, interlocks).
- Do not reach into moving blades or feed systems. Allow all coasting parts to come to a complete stop.
- Electrical power supply and air supply must both be locked out.
- Where established lockout procedures cannot be used (electrical troubleshooting or mechanical dynamic troubleshooting), alternative effective protective techniques shall be employed which may require special skills and planning.
- Always follow safe operations practices in the workplace.

**EQUIPMENT LOCKOUT PROCEDURE**

Lockout procedures per OSHA regulation 1910.147, appendix A:

**GENERAL**

The following simple lockout procedure is provided to assist owner/operators in developing their procedures so they meet the requirements of **OSHA regulation 1910.147**. When the energy isolating devices are not lockable, tagout may be used, provided the owner/operator complies with the provisions of the standard which require additional training and more rigorous periodic inspections. When tagout is used and the energy isolating devices are lockable, the owner/operator must provide full operator protection (see OSHA regulation 1910.147, paragraph (c)(3)) and additional training and more rigorous periodic inspections are required. For more complex systems, more comprehensive procedures may need to be developed, documented, and utilized.

**PURPOSE**

This procedure establishes the minimum requirements for the lockout of energy isolating devices whenever maintenance or servicing is done on machines or equipment. It shall be used to ensure that the machine or equipment is stopped, isolated from all potentially hazardous energy sources and locked out before personnel perform any servicing or maintenance where the unexpected energization or start-up of the machine or equipment or release of stored energy could cause injury.

**COMPLIANCE WITH THIS PROGRAM**

All personnel are required to comply with the restrictions and limitations imposed upon them during the use of lockout. The authorized personnel are required to perform the lockout in accordance with this procedure. All operators,

upon observing a machine or piece of equipment which is locked out to perform servicing or maintenance shall not attempt to start, energize, or use that machine or equipment.

### SEQUENCE OF LOCKOUT

1. Notify all affected personnel that servicing or maintenance is required on a machine or equipment and that the machine or equipment must be shut down and locked out to perform the servicing or maintenance.
2. The authorized employee shall refer to the company procedure to identify the type and magnitude of the energy that the machine or equipment utilizes, shall understand the hazards of the energy, and shall know the methods to control the energy.
3. If the machine or equipment is operating, shut it down by the normal stopping procedure (depress the stop button, open switch, close valve, etc.).
4. De-activate the energy isolating device(s) so that the machine or equipment is isolated from the energy source(s).
5. Lock out the energy isolating device(s) with assigned individual lock(s).
6. Stored or residual energy (such as that in capacitors, springs, elevated machine members, rotating flywheels, hydraulic systems, and air, gas, steam, or water pressure, etc.) must be dissipated or restrained by methods such as grounding, repositioning, blocking, bleeding down, etc.
7. Ensure that the equipment is disconnected from the energy source(s) by first checking that no personnel are exposed, then verify the isolation of the equipment by operating the push button or other normal operating control(s) or by testing to make certain the equipment will not operate.



**CAUTION!** Return operating control(s) to neutral or "off" position after verifying the isolation of the equipment.

8. The machine or equipment is now locked out.

### RESTORING EQUIPMENT TO SERVICE

When the servicing or maintenance is completed and the machine or equipment is ready to return to normal operating condition, the following steps shall be taken.

1. Check the machine or equipment and the immediate area around the machine to ensure that nonessential items have been removed and that the machine or equipment components are operationally intact.
2. Check the work area to ensure that all personnel have been safely positioned or removed from the area.
3. Verify that the controls are in neutral.
4. Remove the lockout devices and re-energize the machine or equipment.

**NOTE:** The removal of some forms of blocking may require re-energization of the machine before safe removal.

5. Notify affected personnel that the servicing or maintenance is completed and the machine or equipment is ready for use.

### PROCEDURE INVOLVING MORE THAN ONE PERSON

In the preceding steps, if more than one individual is required to lock out the equipment, **each shall place his own personal lock on the energy isolating devices.**

## SECTION 3 SAWMILL ASSEMBLY

**CAREFUL PLANNING IS ESSENTIAL TO A SMOOTH ASSEMBLY.**

**READ THIS SECTION THOROUGHLY TO PLAN THE ASSEMBLY.**

**NOTICE:** Do not unbolt all the shipping brackets at once. Remove the shipping brackets securing the sawmill to the pallet at each step to prevent inadvertent shifting of the parts.

### 3.1 Tools required

- Lifting device (fork lift, crane, etc.)
- Socket set, metric and imperial
- Open-end wrench set, metric and imperial
- Socket driver
- Utility knife
- Two (or more) blocks, **minimum 3-1/2" tall**, (nominal 4x4) to set the saw head on while assembling the bed.

### 3.2 Uncrating the mill

1. Remove any shipping straps or plastic coverings from the mill before beginning.
2. Ensure all shipping restraints for the saw head and mast are removed prior to performing the next step.



**WARNING!** Use a fork lift, crane, or other lifting device to remove the saw head from the packing crate. Failure to follow this may result in serious injury or death.

3. Securely attach lifting straps of your lifting device (fork lift, crane, etc.) to the top of the mast as shown in Figure 3-1.

**NOTICE:** Do not attempt to set the carriage down on any surface other than the bed rails. Equipment damage may occur.

# 3 Sawmill Assembly

*Uncrating the mill*

See Figure 3-1.

**NOTICE:** Do not catch wires between lifting strap and frame.

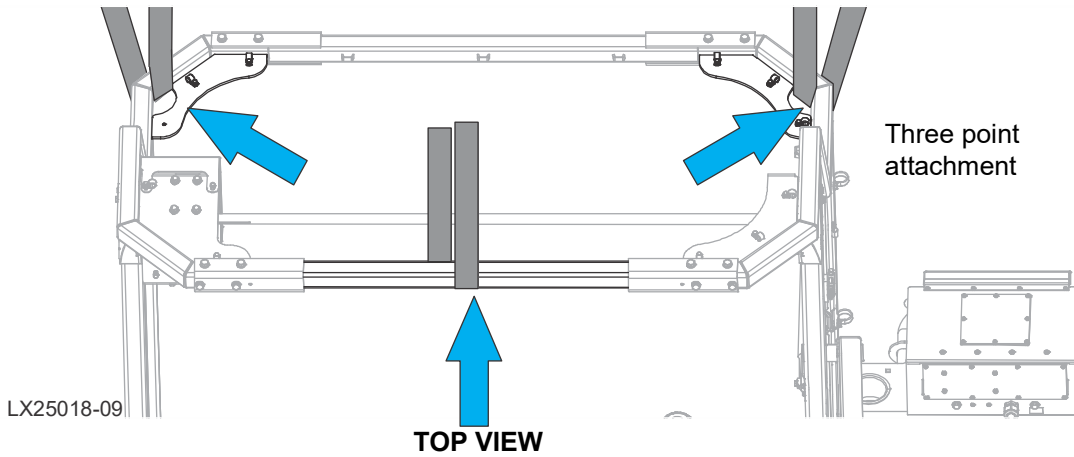



FIG. 3-1

**NOTICE:** Raise the saw head slowly to adjust for load shift. The saw head is heavier on the engine side.

- 4. Set the mast on the blocks called out in Section 3.1 Tools required. See Figure 3-2.

 **CAUTION!** Use care to protect the adjustment screws at the bottom of the mast. See Figure 3-2.

See Figure 3-2.

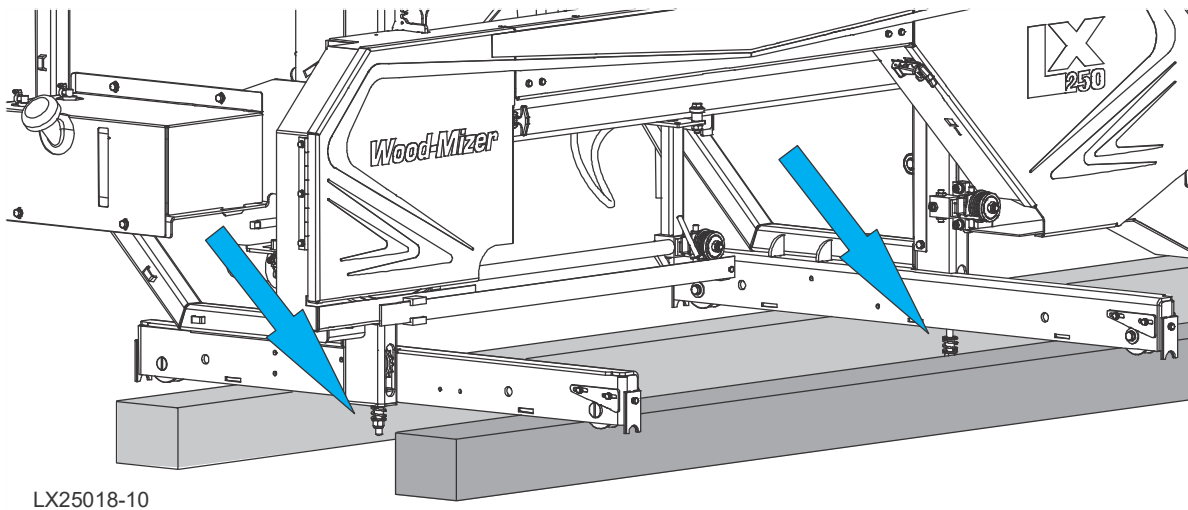

FIG. 3-2



5. Remove and inspect the parts boxes.



**WARNING!** Leave the blade in its box until you have reviewed the video on safe blade handling. Failure to follow this may result in serious injury or death.

See Figure 3-3.



FIG. 3-3

TABLE 1: PARTS BOX CONTENTS

Part #	Description	Qty
	Kohler Engine Manual	1
	<b>Hardware bag</b>	1
F05004-250	Bolt, M12x1.75x40mm HH FT CL10.9 Zinc	6
F05011-124	Washer, M12 FLAT Zinc	12
F05010-209	Nut, M12x1.75 Hex Nylock	6
115110	Shim, End Stop	4
115290	Chain, #40x460 Pitches (230")	2
115106	End Stop Right	2
115112	End Stop Left	2
015721	Tensioner Wldmt, Power Feed Chain (on End Stops)	4
128014	Bed Shim, LX250 16Ga	22
128015	Bed Shim, LX250 16Ga	22
128016	Bed Shim, LX250 7Ga	11

The Power Feed motors and one motor mount are packaged separately. The second Power Feed motor mount is bolted on the exterior of the bed frame sections.

# 3 Sawmill Assembly

*Uncrating the mill*

See Figure 3-4.

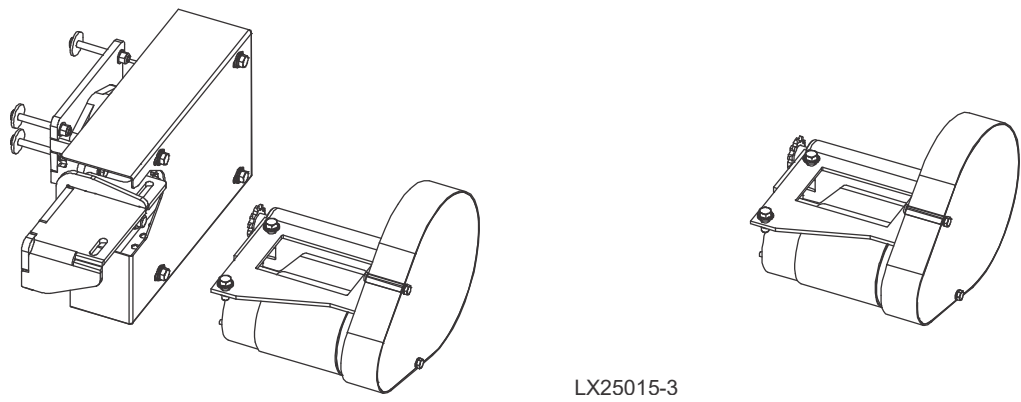

FIG. 3-4

The manual bag, located inside the saw head cover, also includes a belt tension gauge (016309) and a Blade Guide Alignment Tool (LTBGAT).

See Figure 3-5.

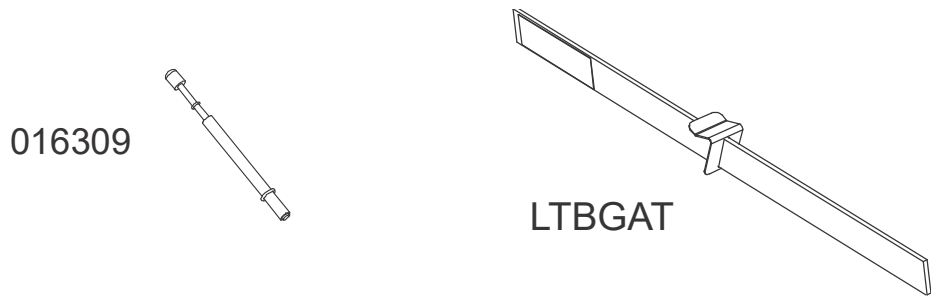
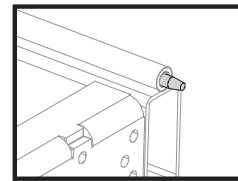

FIG. 3-5

### 3.3 Assemble the bed

- Area must be firm and level.
- Allow maneuvering room for operators, sawdust removal, log loading, and board removal.

**NOTICE:** Observe the direction of the alignment pins in relation to the remaining bed sections. Plan the assembly such that the log supports are on the same side as the operator's station, and such that the section without a log support is at the head of the log bed.



**NOTE:** Ensure the bed is assembled in the final operating location. Once assembled, it should not be moved.

1. Unbolt the power feed unit from the shipping location; set it aside for later mounting.
2. Unbolt the 11 bed legs from the shipping crate.
3. Ensure all shipping restraints are removed from the top section prior to performing the next step.



**WARNING!** Use a fork lift, crane, or other lifting device to remove the saw head from the packing crate. Failure to follow this may result in serious injury or death.

**NOTE:** The three sections of the bed have the same frame, but they can be distinguished as:

The head section has no clamp and no decal  
The center section has a clamp and no decal  
The foot section has a clamp and a decal

4. Securely attach lifting straps to the top bed section and lift the bed section.

### 3 Sawmill Assembly

*Assemble the bed*

See Figure 3-6.



FIG. 3-6

5. Loosely attach 3 bed feet while the bed is suspended.

See Figure 3-7.

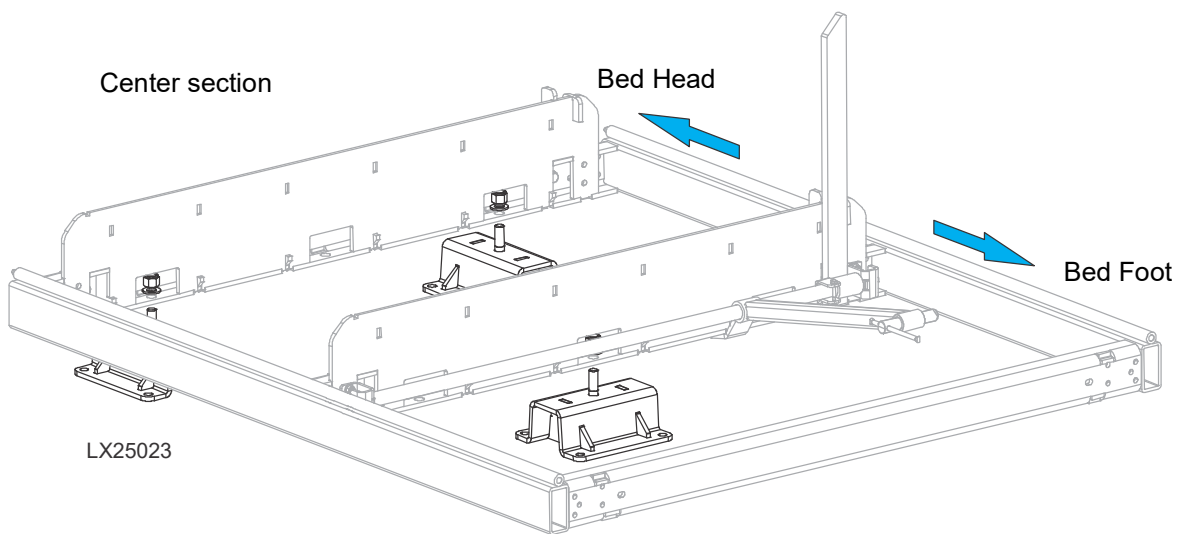

FIG. 3-7

6. Set the bed section on its feet.
7. Repeat steps 2 through 6 for the next bed section.

### CONNECT BED SECTIONS

- Align the rail pins.
- Draw the bed sections together and secure with fasteners from the hardware bag. See Fig. 3-8.

**NOTE:** If necessary to draw the bed segments tightly together, use a large C-clamp, a rubber mallet, or a sledge hammer with a wooden block.

See Figure 3-8.

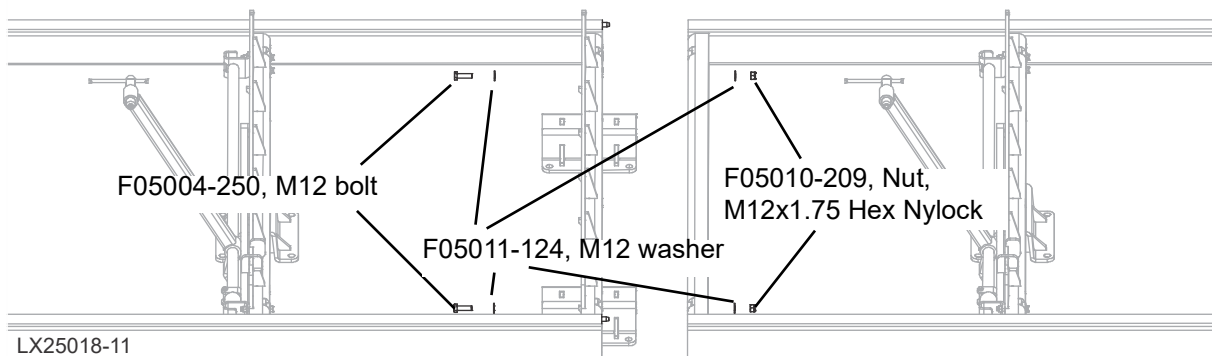
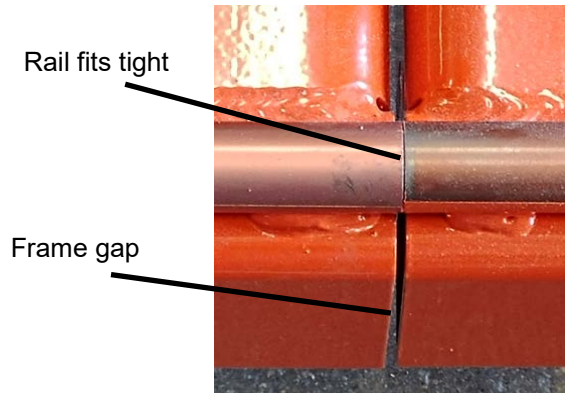

FIG. 3-8

**NOTE:** The top surface (round rails) touch before the square support tubes, leaving a small (1/8" +/-) gap. This is normal. Do not attempt to draw the square support tubes together. See Figure 3-9.

Make sure the top surfaces (round rails) of the bed sections are smoothly aligned. It may be necessary to adjust one bed section up or down with bed shims until the surfaces are aligned.

See Figure 3-9.



**FIG. 3-9**

10. Recheck that the rail joints are tight and smooth.
11. Tighten the bed section bolts.
12. Level the bed sections as you go.

See Figure 3-10.

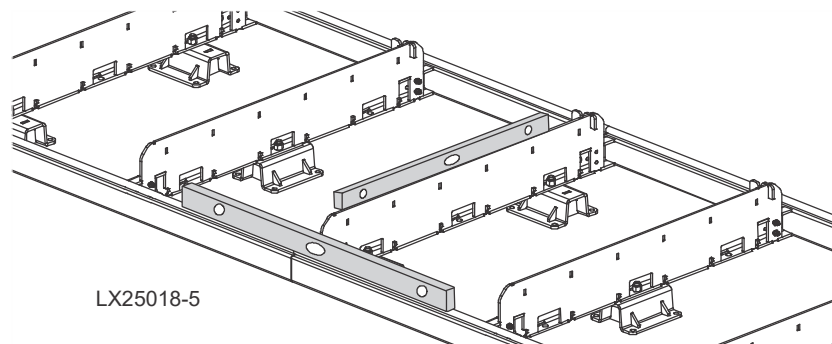

**FIG. 3-10**

13. Shim as needed.

See Figure 3-11.

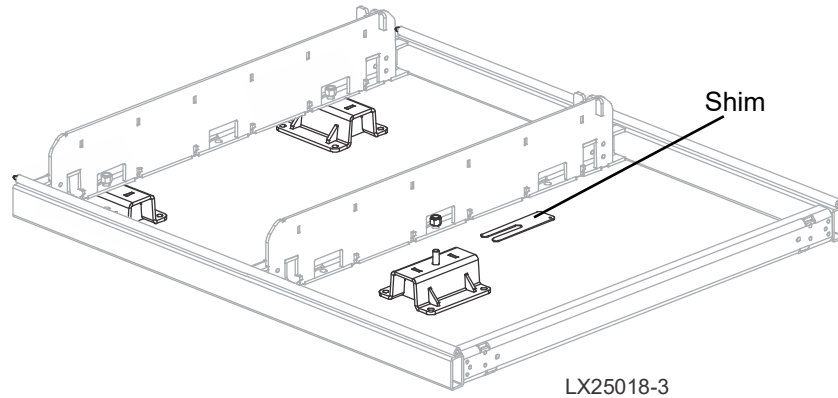

FIG. 3-11

- Repeat steps 2 through step 13 for the last bed section.

### 3.4 End Stop Assemblies

**NOTICE:** The end stops (bumpers) are left/right oriented.

- Mount the end stops to the frame with the shims between the frame and the end stops.

See Figure 3-12.

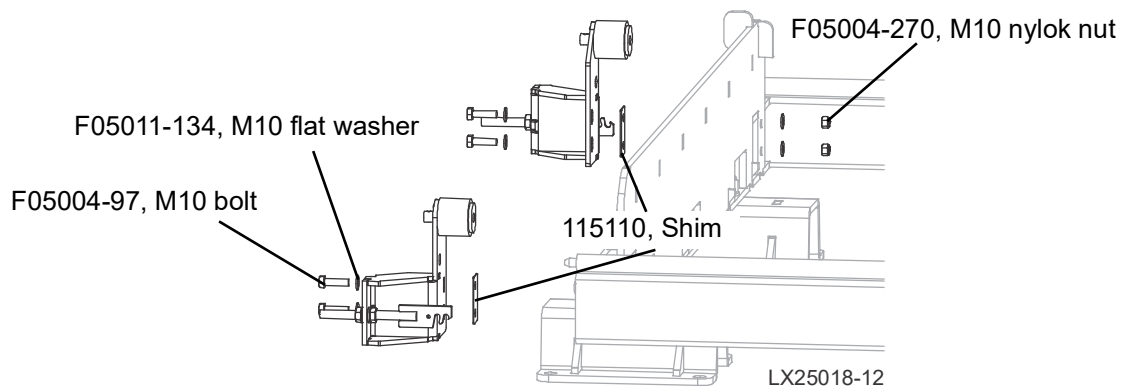

FIG. 3-12

### 3.5 Adjusting/leveling the Bed

**NOTE:** Adjusting/leveling the log bed is best done before the saw head is installed.

1. Adjust the frame legs so the sawmill appears level; use shims under the legs, if necessary.

See Figure 3-13.

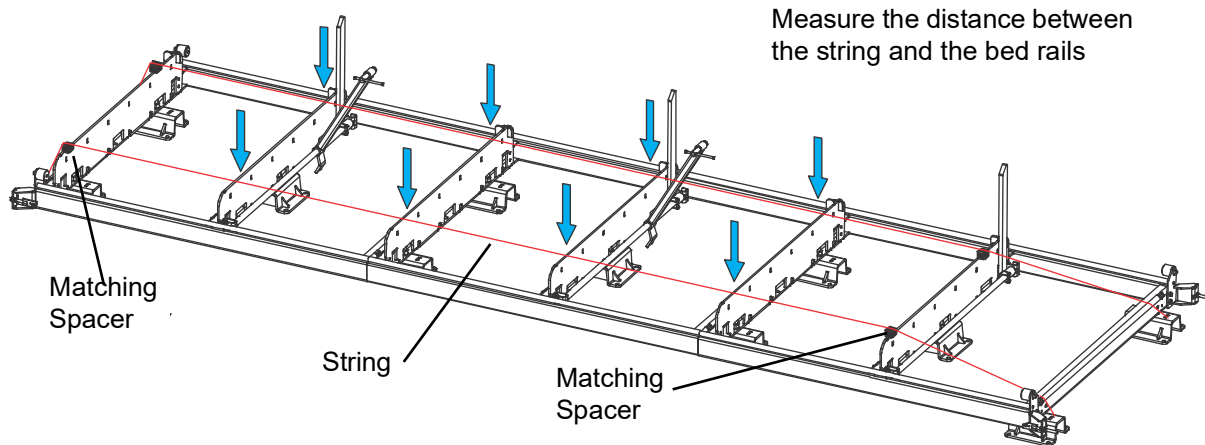

FIG. 3-13

2. Run a string from the front bed rail to the rear bed rail near the operator's side of the frame. See Figure 3-13.
3. Place **IDENTICAL** matching spacers between the string and the front and rear bed rails.
4. Measure the distance between the string and the other bed rails.
5. Adjust the frame legs until all bed rails measure the same distance from the string.
6. Repeat the bed rail adjustment with the string at the other side of the sawmill frame.

### 3.6 Saw Carriage Assembly

1. Check the orientation of the carriage before placing it on the bed frame; the operator is on the same side as the log supports.
2. Position the saw head over the end of the bed frame assembly.
3. Carefully lower the saw head on the bed frame, sliding the saw head rollers onto the bed rail while maneuvering the saw head square to the bed to avoid jamming the track rollers.
4. Remount the mast safety assemblies (right and left) from the transport position to the operating position. See Figure 3-14.



**NOTE:** There should be no more than an 1/8" clearance between the mast safety assembly and the bed rail.

5. Ensure the white rail wipers make firm contact with the rails: the wiper mounting plate should not set on the rail.

See Figure 3-14.

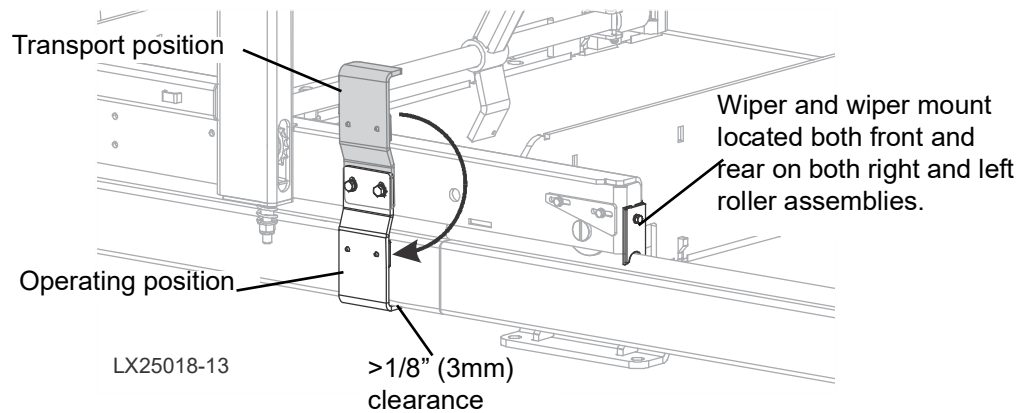

FIG. 3-14

### 3.7 Feed Drive Assembly

1. Unpack the Power Feed drive assemblies from the boxes, and retrieve the mount assembly set aside in section 3.3, step 1.
2. Thread the Power Feed chain through the sprockets.

# 3 Sawmill Assembly

## Feed Drive Assembly

See Figure 3-15.

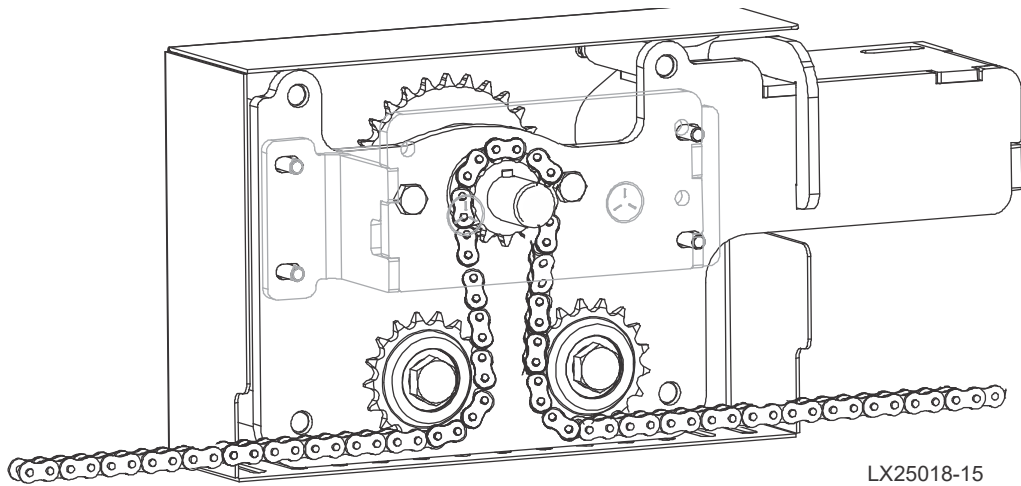

FIG. 3-15

3. Assemble the Power Feed mount (without cover) as shown in Fig 3-16.

See Figure 3-16.

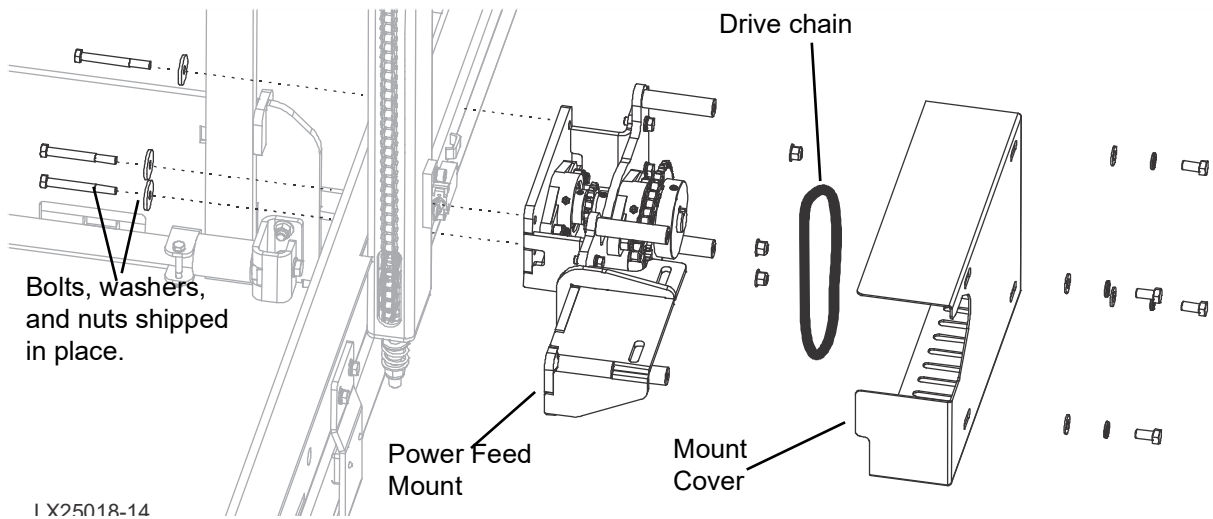

FIG. 3-16

4. Attach the drive chain by simply hanging it on the drive sprocket.

5. Mount the Power Feed drive assembly.

**NOTE:** Catch the drive sprocket in the drive chain while mounting. It will be difficult to attach after the motor is in place.

See Figure 3-17.

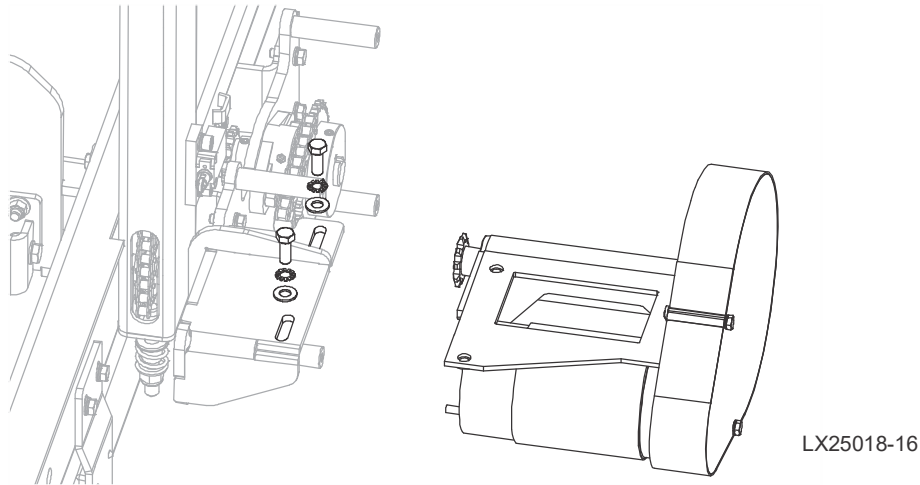

**FIG. 3-17**

6. Slide the drive assembly in the mounting slots until the all loose slack in the drive chain has been taken up. **DO NOT OVER TIGHTEN THE DRIVE CHAIN.**
7. Power Feed chain should measure 7-8 inches at the apex from the top of the chain to the top of the bed rail.

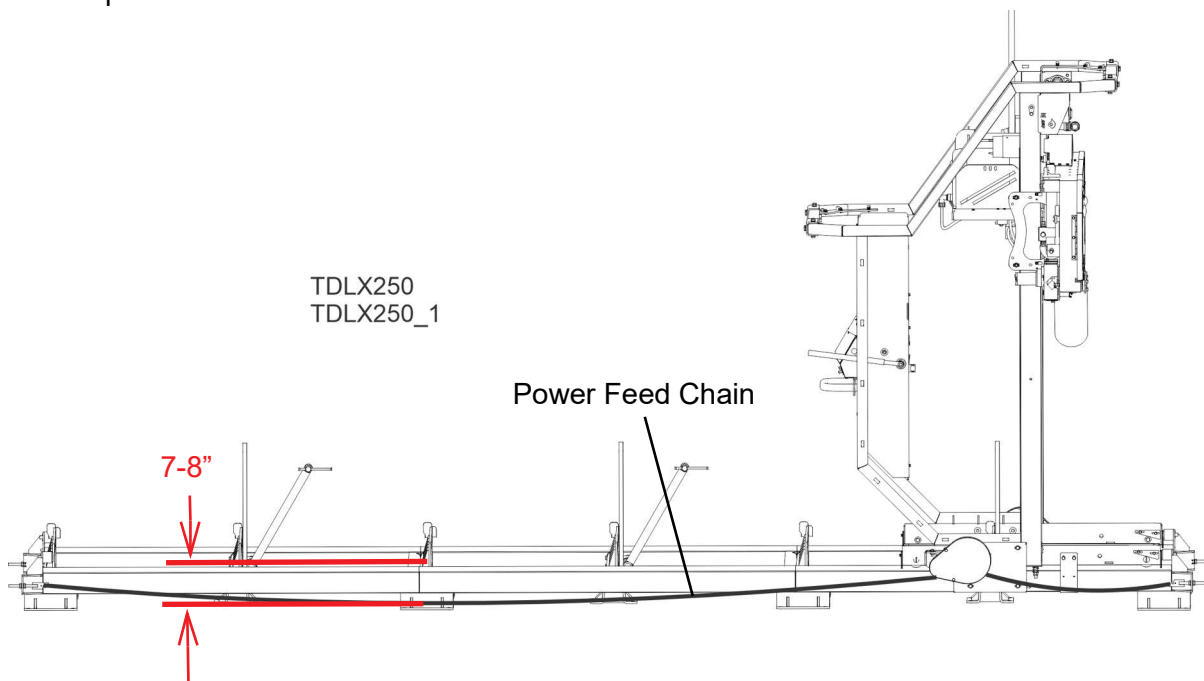

8. Tighten the mounting screws.

NOTE: The following steps may be difficult due to the location of the motor terminals.

9. Attach the wiring harness to the motor.

**NOTICE:** The DC Power Feed motors will be wired differently for the left and right motors because the motors are mounted in a mirrored position.

- a. Remove the blue and green wires (with caps) from the transport position near the Power Feed motors.
- b. Slide the protective caps up the wires to expose the ring terminals.
- c. Unscrew the nut-with-star-washer (Keps™ nut) from the positive terminal on the motor.
- d. Place the wire ring terminals over the motor studs as shown in Fig. 3-18.

See Figure 3-18.

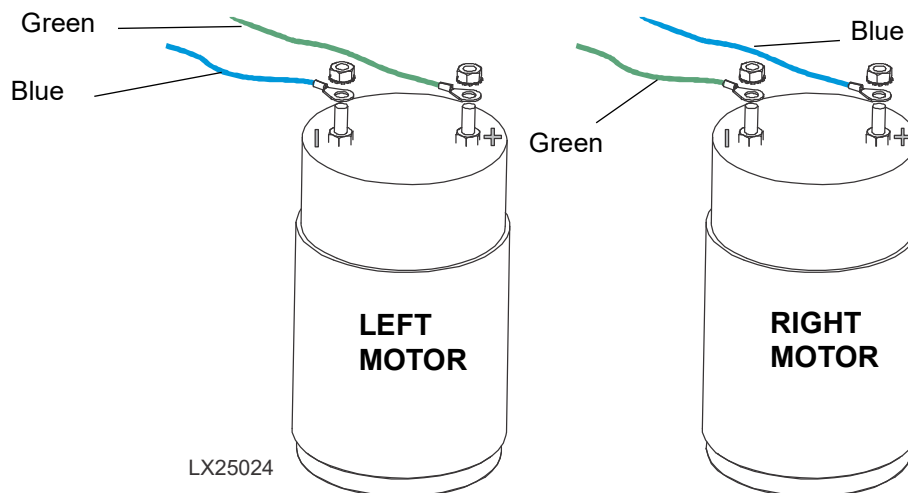

FIG. 3-18

- e. Tighten the nuts.
  - f. Slide the protective caps over the terminals.
10. Install the Mount Cover. (See Fig. 3-16.)

**11.** Repeat steps 2 through 10 for the other side.

## SECTION 4 SAWMILL SETUP

The following setup procedure should be performed whenever the sawmill is moved or reassembled. If sawing problems occur and misalignment is suspected, [See Section SECTION 7](#) for complete alignment instructions.

[See Section SECTION 8](#) for sawmill assembly instructions.



**DANGER!** Do not use a gas engine indoors. Failure to follow this will result in serious injury

**NOTICE:** Set up conditions include:

- Set up the sawmill on firm, level ground and level the sawmill.
- Use a sawdust collection system when operating under roof or indoors (electric only).
- When operating the sawmill outdoors, set up the sawmill placing the operator downwind to separate the operator from sawdust and/or engine exhaust gases.

### 4.1 Installing the Blade



**WARNING!** Wear gloves and eye protection when handling bandsaw blades.

**WARNING!** Keep all other persons away from area when coiling, carrying, or changing a blade. Changing blades is safest when done by one person.

1. Open the blade housing cover.

Turn the blade tension bar with the ratchet until the blade wheel is moved in. See FIG. 4-1

2. Place the new blade around the blade wheels.

**NOTE:** When installing a blade, make sure the teeth are pointing the correct direction. The teeth should be pointing toward the operator side of the mill when you are looking at the blade below the blade guides.

3. Position 1 1/4" wide blades (standard) on the wheels so the gullet is 1/8" (3.0 mm) out from the edge of the wheel.

## 4.2 Tensioning The Blade

Use the supplied handle to turn the tensioner handle clockwise until the tension gauge indicates 1500-1700 PSI tension.

4. Check the blade tension when adjusting the cant control or making other adjustments.

**NOTE:** Check the blade tension after prolong use. The blade and belts heat up and stretch, the blade tension will change.

5. Check the blade tension when there are changes in the ambient temperature.

## 4.3 Tracking The Blade

 **WARNING!** Do not spin the blade wheels by hand.

1. Ensure the blade housing cover is closed and all persons are clear of the open side of the saw head.

 **DANGER!** Always be sure the blade is disengaged and all persons are out of the path of the blade before starting the engine or motor. Failure to follow this will result in serious injury

 **WARNING!** Make sure all guards and covers are in place and secured before operating the sawmill.

2. Start the engine.

**NOTICE:** See the appropriate manual supplied with your specific engine/motor configuration for starting and operating instructions.

3. Engage the blade momentarily, rotating the blade until the blade positions itself on the wheels.
4. Disengage the blade.
5. Turn off the engine, remove the key, and check the position of the blade on the blade wheels.
6. Use the cant control to adjust where the blade travels on the blade wheels.

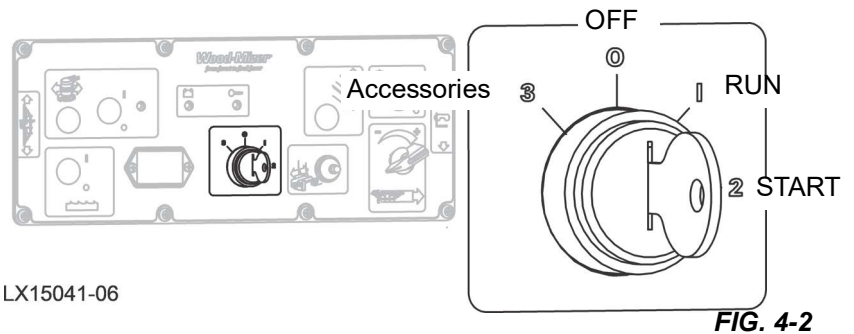
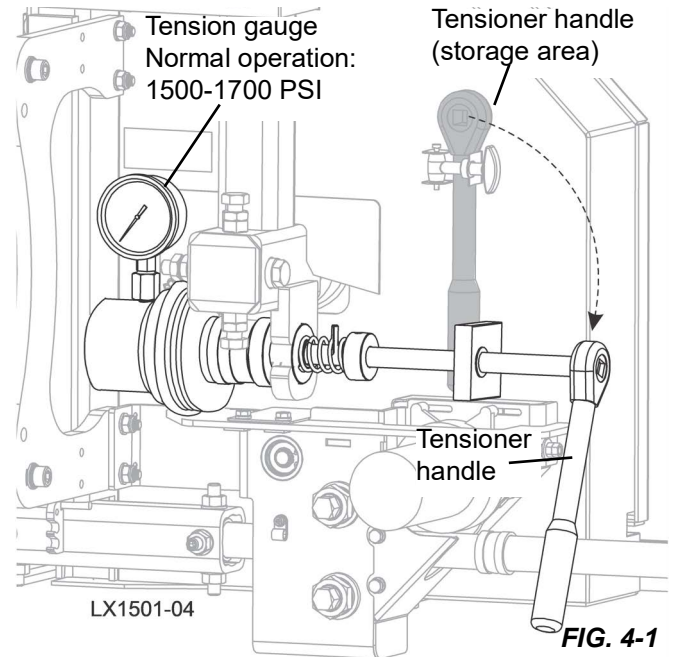

**NOTE:** If the blade is too far out, back the blade onto the wheel by turning the cant control counterclockwise. If the blade is too far in, turn the cant control clockwise until the gullet of the blade is the correct distance from the front edge of the wheel.

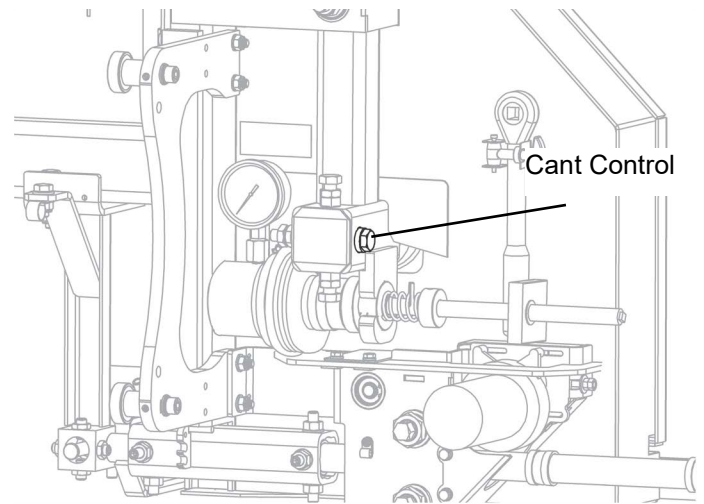

FIG. 4-3

Position 1 1/4" wide blades so the gullet is 1/8" (3.0 mm) out from the edge of the blade wheel ( $\pm 1/32$  [.75 mm]).

7. Adjust the blade tension if necessary to compensate for any changes that may have occurred while adjusting the cant control.
8. Close the blade housing covers and ensure blade housing and pulley covers are in place and secure



**WARNING!** Make sure all guards and covers are in place and secured before operating the sawmill.

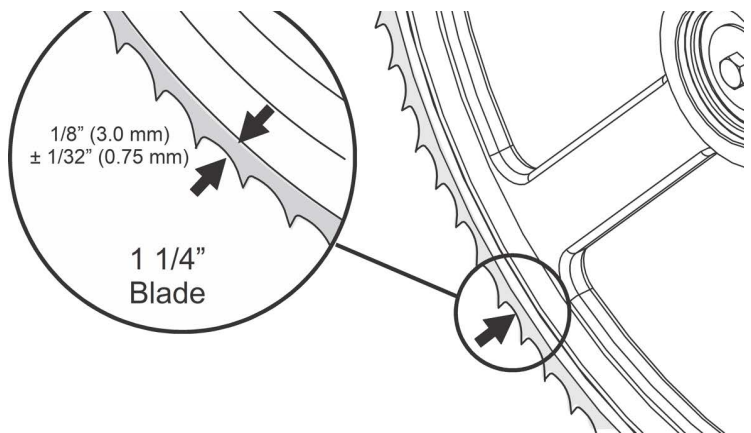

FIG. 4-4

**NOTICE:** After aligning the blade on the wheels, always double-check the blade guide spacing and location.

## 4.4 Sawhead Tilt

The sawhead is aligned so the blade is parallel to the bed rails at the factory. Before continuing, check the alignment and adjust if necessary. [See \*Saw Head Tilt\*](#) Section 9: Sawmill Alignment.

## 4.5 Sawblade

### Blade Guide Vertical Tilt Alignment

The blade guides should be adjusted properly in the vertical plane. If the blade guides are tilted vertically, the blade will try to travel in the tilted direction.

A Blade Guide Alignment Tool (BGAT) is provided to help you measure the vertical tilt of the blade.

### OUTER BLADE GUIDE

1. Open the adjustable blade guide arm 1/2" (13 mm) from fully open.
2. Clip the alignment tool on the blade.
3. Position the tool close to the outer blade guide assembly.

**NOTE:** Be sure the tool does not rest on a tooth or burr, and is lying flat against the bottom of the blade.

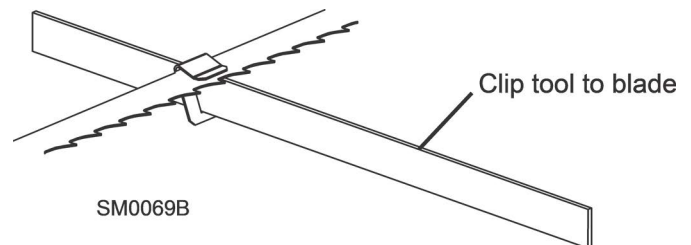

FIG. 4-5



4. Move the carriage so that the **front** end of the tool is positioned above the bed rail.
5. Measure the distance from the bed rail to the bottom edge of the tool.
6. Move the carriage so that the **back** end of the tool is positioned above the bed rail.
7. Measure the distance from the bed rail to the bottom edge of the tool.

If the measurement from the tool to the bed rail is not equal within 1/32" (.75 mm), adjust the vertical tilt of the outer blade guide roller.

8. Loosen one set screw at the side of the blade guide assembly.
9. Loosen the jam nuts on the top and bottom vertical tilt adjustment screws.
  - a. To tilt the roller up, loosen the bottom screw and tighten top screw.
  - b. To tilt the roller down, loosen the top screw and tighten the bottom screw.

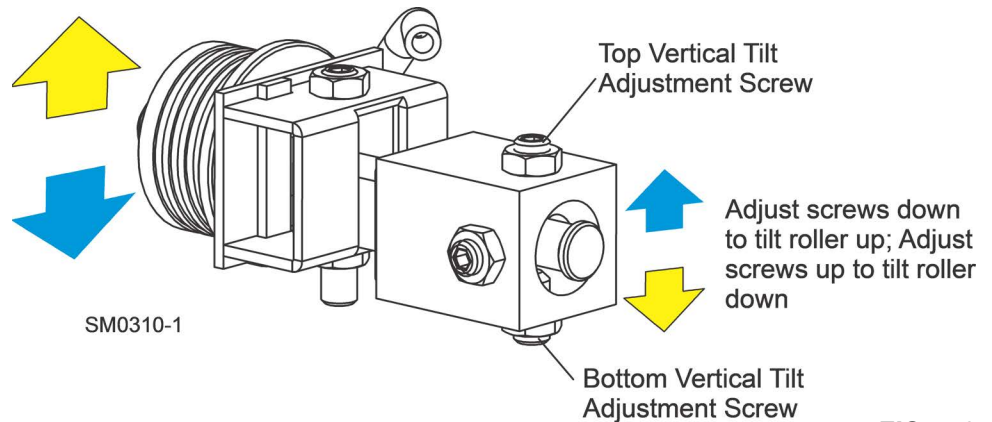

FIG. 4-6

10. Tighten the jam nuts and recheck the tilt of the blade.

## INNER BLADE GUIDE

11. Move the blade guide alignment tool close to the inner blade guide roller assembly and repeat the above steps.
12. Adjust the vertical tilt of the inner blade guide, if necessary.

## Blade Guide Flange Spacing

Each blade guide must be adjusted so the roller flange is the correct distance from the back edge of the blade. If the flange is too close to or too far from the blade, the sawmill will not cut accurately.

The blade guide rollers should also be slightly cocked. If the moving blade makes contact with the leading flange edge of the roller, momentum may cause the blade to slip over the flange. Contact with the trailing edge would force the blade upward onto the roller.

**NOTICE:** When adjusting blade guide spacing, **loosen the top set screw and one side set screw only.** This will ensure horizontal and vertical tilt adjustments are maintained when the adjustment screws are retightened.

## OUTER BLADE GUIDE

1. Ensure that the distance between the flange on the **outer blade guide roller** to the back edge of the blade measures to 1/8" (3.0 mm).

Adjust the roller back or forward if necessary.

2. Loosen the top screw and one side screw.

3. Gently tap the blade guide forward or backward until properly positioned.

4. Retighten the screws and jam nuts.

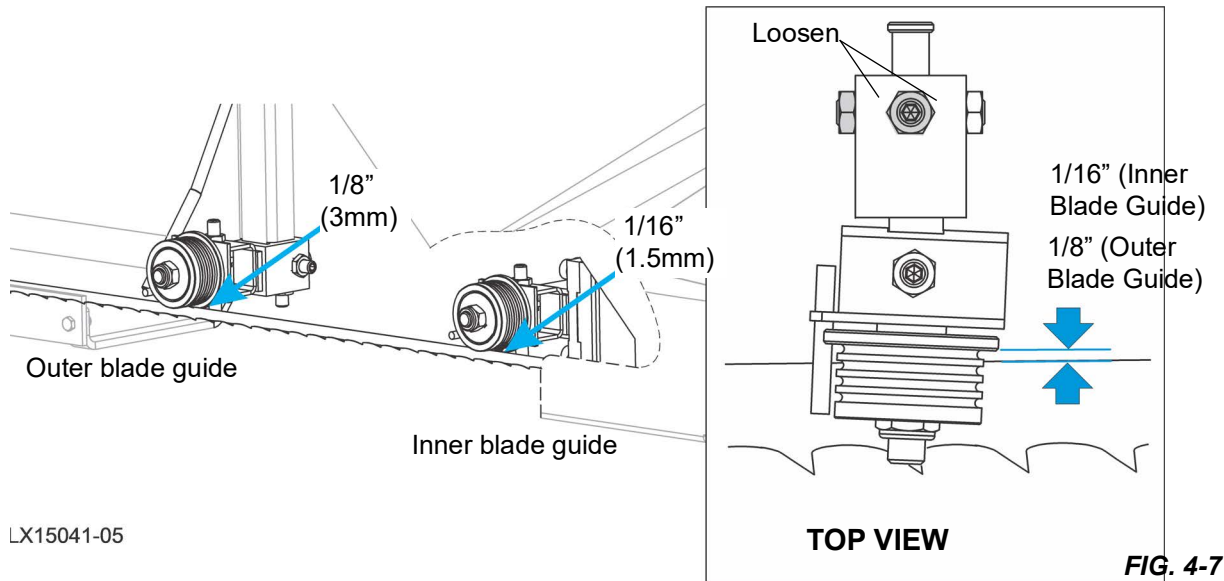

## INNER BLADE GUIDE

LX15041-05

5. Ensure that the distance between the flange on the **inner blade guide roller** to the back edge of the blade measures to 1/16" (1.5 mm). See Figure 4-7.
6. Adjust the roller back or forward, as described above.

## 4.6 Starting The Engine



**DANGER!** Always be sure the blade is disengaged and all persons are out of the path of the blade before starting the engine or motor. Failure to follow this will result in serious injury



**WARNING!** Make sure all guards and covers are in place and secured before operating the sawmill.

Electrical systems will run with the key in the Accessories (3) position; however, you risk running your battery down.

See the manual supplied with your specific engine/motor configuration for starting and operating instructions.

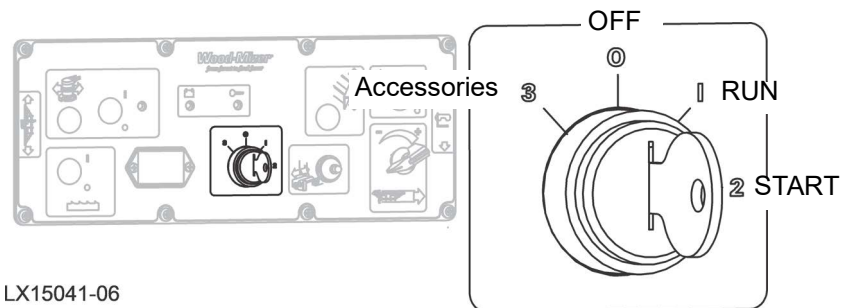

## SECTION 5 SAWMILL OPERATION

### 5.1 Manual Power Feed

The power feed system moves the mast forward and backward by using the two switches on the control panel illustrated below.

See Figure 5-1.

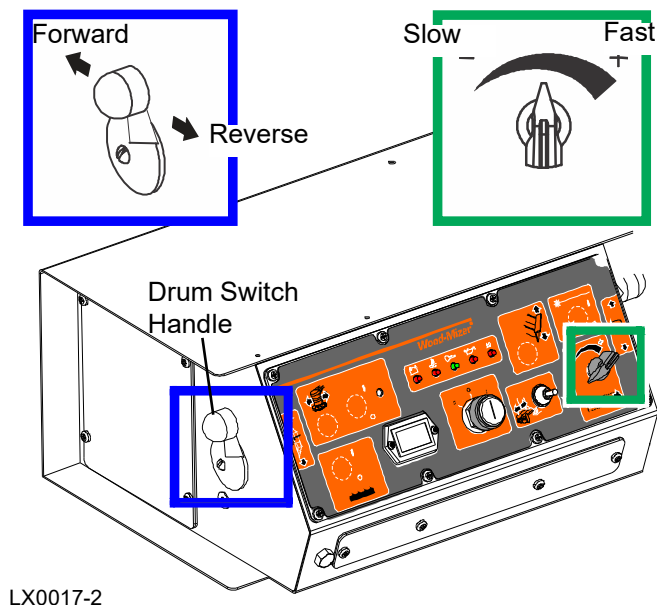

FIG. 5-1

#### MAST FORWARD AND REVERSE

The mast forward/reverse drum switch controls the direction in which the mast travels.

The middle position (as shown) is the neutral position. The power feed switch is designed to return to the neutral or "off" position when released from operating in the reverse position. If the switch remains engaged, manually move the switch to the neutral or "off" position and [See Section 1.6](#).



**WARNING!** Ensure the power feed switch is in the neutral position before turning the key switch to the on (1) or accessory (3) position to prevent accidental mast movement. Failure to follow this will result in death or serious injury.

**MAST FEED RATE**

The mast feed rate switch controls the speed at which the mast travels forward. Turn the switch clockwise to increase speed. Turn it counterclockwise to reduce speed.

**USING THE POWER FEED**

1. Use the forward/reverse drum switch and the feed rate switch to position the sawhead for the cut.
2. Engage the clutch to start the blade.
3. Set the feed rate relative to the size and material you are cutting. If not known, set at the slowest rate.

**HINT:** To get a straight cut in the first part of the board, feed the blade into the log at a slow speed. Turn the mast feed rate switch to a slow speed until the whole width of the blade has entered the cut. This stops the blade from flexing and dipping up or down. Then use the mast feed rate switch to increase the feed rate as desired. Maximum feed rate varies with width and hardness of the wood. Over-feeding results in engine and blade wear, and also produces a wavy cut.

4. Press and lock power feed handle forward to move forward.
5. Stop the mast at the end of the cut by raising (unlocking) the feed handle, or by turning the mast feed rate switch counterclockwise until the mast stops moving.
6. Disengage the blade by setting the clutch handle up. The engine will drop to idle.
7. Remove the board from the top of the log.



**CAUTION!** Be sure to stop the blade when returning the mast. This will not only prevent the blade from being pulled off and ruined by a wood sliver, but also will increase the life of the blade.

8. Raise the mast slightly to ensure the blade clears the log when returned.
9. Return the mast to the front of the mill by pushing the forward/reverse drum switch back.

**NOTICE:** The power feed motor will bypass the mast feed rate switch and the mast will automatically return at the fastest speed available.



**DANGER!** Stay clear of the area between the trailer axle and saw mast. Failure to follow this will result in death or serious injury.

## 5.2 Manual Up/Down Operation

 **CAUTION!** Ensure the blade is properly installed and tensioned before moving the sawhead.

1. Use the up/down drum switch located on the right side of the control panel to raise or lower the cutting head.
2. Hold the switch in position until the cutting head reaches the desired height, then release.

See Figure 5-2.

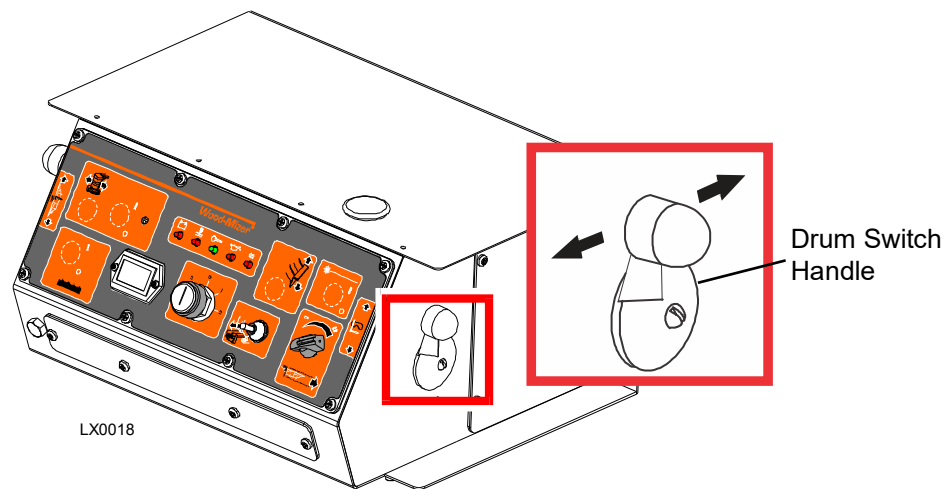



FIG. 5-2

 **CAUTION!** Ensure the up/down drum switch moves to the neutral (off) position when released to ensure that the saw head stops moving. If the switch remains engaged, manually move the switch to the neutral or "off" position, then troubleshoot the switch.

 **CAUTION!** DO NOT try to force the mast above the 35" (88 cm) mark or below the 1" (2.54 cm) mark. Damage to the up/down system may result.

## 5.3 Up/Down (Simple Set Operation)

As the Simple Set control powers up, the software revision is displayed. This information can be helpful should you require service. Simple Set opens in Manual mode.

See Figure 5-3.



FIG. 5-3

### Changing the Default Setup

Simple Set is factory set. To change the default settings, hold down the Manual button and use the Scroll Up button to enter the Setup Menu. Use the Auto button to move between setup criteria.

See Figure 5-4.



FIG. 5-4

The Setup Menu consist of:

- Saw Head Up/Down Speed: 1-5, with 5 (default) being the fastest

**NOTE:** Lowering the set speed will assist in achieving the desired blade height setting in situations where the up/down chains or mast pads are worn or loose

- Units of Measure: Standard (default) or Metric (millimeters).
- Language: English only

- Exit Setup by using the **Manual** button.

### Operation

#### MANUAL OPERATION

1. Select the **Manual** button, if not already in manual mode by default.
2. Refer to Manual Up/Down operation (previous section) for operation.

**NOTE:** The display will show a 'D' when the drum switch is pushed down and a 'U' when pushed up.

#### AUTO OPERATION

1. Select the **Auto** button.

In Auto Operation, the saw head will **move down at the set speed** increment when the saw head down drum switch is activated. The saw head will move **up at speed 5 (default)**.

- Two sets of values can be stored in the control. Press the **Auto** button to toggle between Set1 and Set2.
- To set the Set1 or Set2 value, use the **Scroll** buttons to adjust the value in 1/16" (or 1mm) increments. Values are automatically saved and will stay in memory until changed.



**IMPORTANT!** You must add the kerf value to the increments. Typical blade kerfs are between 1/16 - 1/8" (1.6 - 3.2 mm).

- Bump the up/down drum switch down to move the blade to the next increment.

**NOTE:** Holding the drum switch up or down will bypass Simple Set and move the saw head until the drum switch is released.

- If the saw head is raised, bumping the up/down drum switch down will return the saw head to **the original position plus the increment value**.
- Press the **Manual** button to exit auto mode.

Turn the sawmill control key switch to the OFF (0) position to power off Simple Set.

## 5.4 Loading, Turning, & Clamping Logs

### LOADING LOGS

1. Move the saw mast to the front end of the frame.



**CAUTION!** Be sure the log clamps are adjusted out of the path of the log before loading a log onto the bed. Failure to follow this may result in machine damage.

**NOTICE:** The saw mast may be moved without the engine started, but repeated operation in this manner may drain your battery.

2. Lower the log clamps.
3. Raise the side supports on the sawmill bed to prevent the log from falling off the side of the bed.

**NOTICE:** Logs must be loaded onto the mill with a forklift or other equipment specifically designed for that purpose.

4. Position the log against the side supports.

**NOTE:** Position the log on the bed sections to maximize support of the log by the bed. If the log overhangs the bed, it may tend to sag, resulting in inaccurately sawn lumber.

### CLAMPING LOGS



**CAUTION!** Make sure the side supports and clamp are positioned low enough for the blade to pass over them. If they are not, back the clamp off slightly and push the side supports down until they are positioned below the level of your first few cuts. Failure to follow this will result in machine damage.

1. Slide the clamp against the log and turn the locking handle to lock the clamp against the log.
2. Tighten the clamp against the log with the locking handle.



See Figure 5-5.

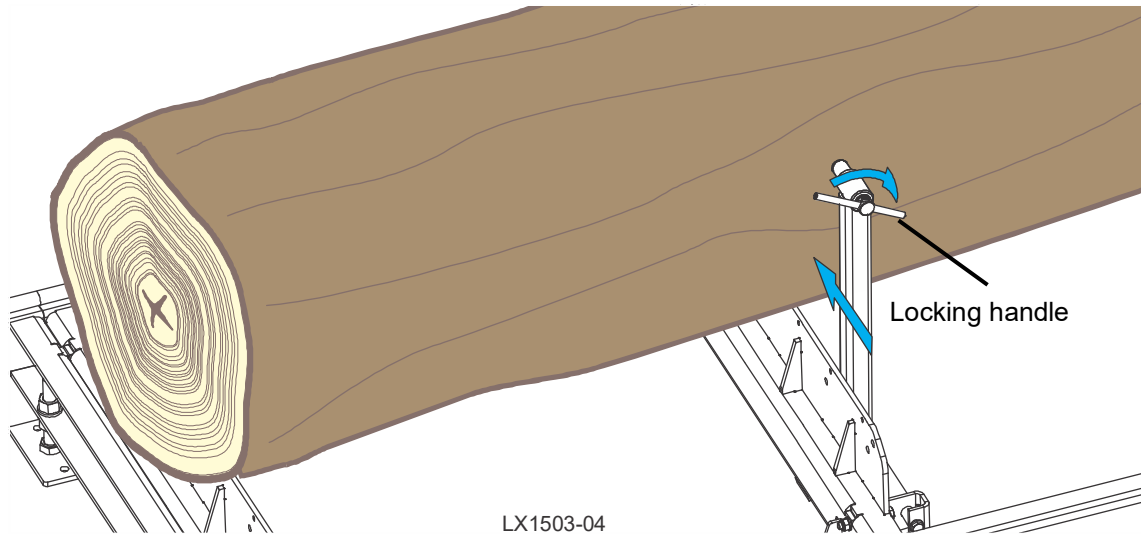
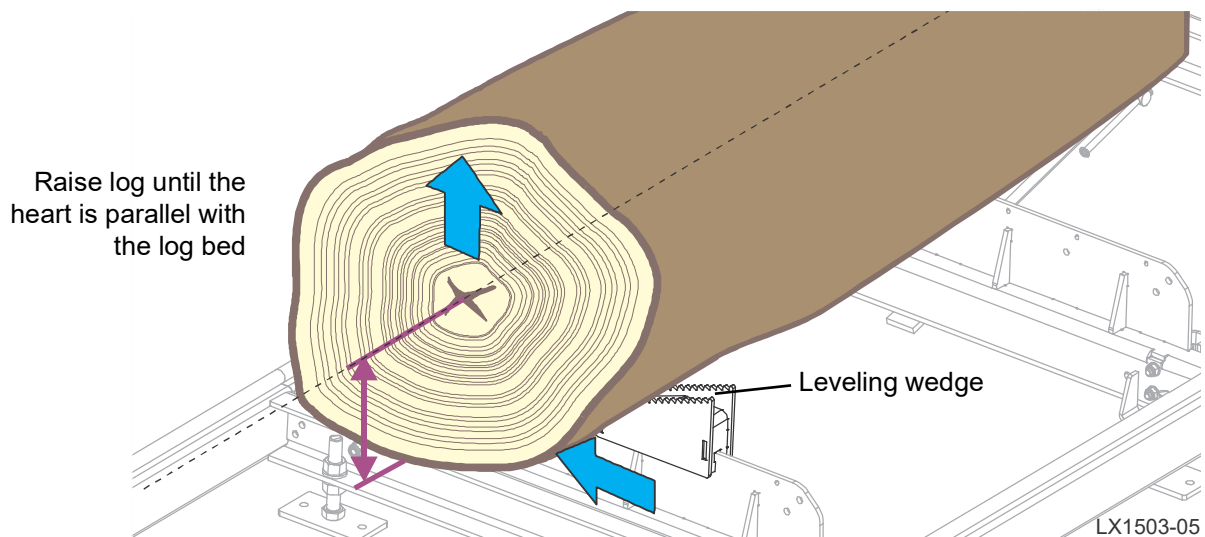

FIG. 5-5

### LEVELING A TAPERED LOG

Use shims or the wedge to raise either end of a tapered log until the heart of the log measures the same distance from the bed rails at each end of the log.

See Figure 5-6.



Raise log until the heart is parallel with the log bed

Leveling wedge

LX1503-05

FIG. 5-6

## 5 Sawmill Operation

### Blade Guide Arm Operation

#### TURNING THE LOG



**CAUTION!** Do not turn the log while on the log bed. Damage to the log bed may result.

Use a forklift to lift the log off of log bed. Once off of the log bed, it can be turned and replaced in the new orientation.

### 5.5 Blade Guide Arm Operation

1. Set the outer blade guide to clear the widest section of the log by less than 1" (25.4 mm).
2. Use the blade guide toggle switch on the control panel to adjust the outer blade guide as necessary.
3. Push the switch to the left to move the arm in; push the switch to the right to move the arm out.

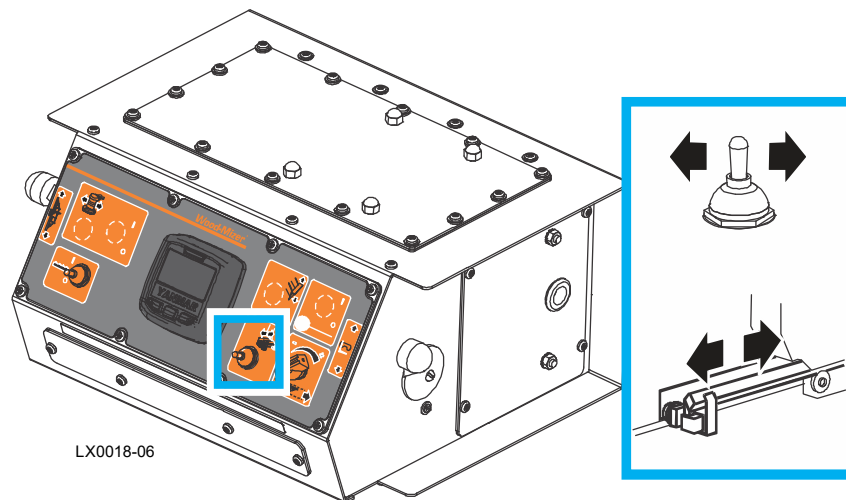

FIG. 5-6

4. Use the blade guide toggle switch to readjust the outer blade guide as you are cutting in order to keep the guide within 1" (2.5 cm) of the log.
5. Adjust the arm out before returning the carriage.

### 5.6 Cutting The Log

1. Once the log is placed where you want it and clamped firmly, move the saw head to position the blade close to the end of the log.
2. Use the blade height scale to determine where to make your first cut ([See Section 5.8](#)).

- 1). Set the blade to the desired height with the up/down crank.
  - 2). Ensure that the blade will clear all side supports and the clamps.
  - 3). Adjust the outer blade guide to clear the widest section of the log by moving the blade guide arm knob.
3. Engage the clutch to start the blade spinning.
  4. Start the water lube if necessary to prevent sap buildup on the blade. [See Section 5.9.](#)
  5. Feed the blade into the log slowly ([See Section 5.6](#)).

Once the blade completely enters the log, increase the feed rate as desired. Always try to cut at the fastest speed you can while keeping an accurate cut. Cutting too slowly will waste blade life and lower production! As you get to the end of the log, slow down the feed rate.

6. When the teeth exit the end of the log, disengage the clutch and remove the cut slab.
7. Return the mast to the front of the mill.
8. Repeat until the first side of the log is cut as desired.
9. Set aside the usable flitches (boards with bark on one or both sides) to edge them later.
10. Remove the wedge if it was used.
11. Remove the clamps and turn the log 90 or 180 degrees.
12. Ensure the flat on the log is placed flat against side supports if turned 90 degrees or it is placed on bed rails if turned 180 degrees.

**NOTICE:** If the log was turned 90 degrees and you are using the wedge to compensate for taper in the log, use the wedge again on the second side of the log until the heart is parallel with the bed.

13. Repeat the steps used to cut the first side of the log until the log is square. Cut boards from the remaining cant by adjusting the blade height for the thickness of boards that you want.

**NOTICE:** Remember that the blade cuts a 1/16 - 1/8" (1.6-3.2 mm) wide kerf. If you want 1" (25.4 mm) thick boards, lower the mast 1 1/16 - 1 1/8" (27-28.6 mm) for each board.

### 5.7 Edging

1. Raise the side supports to 1/2 the height of the flitches, or the boards that need to be edged.
2. Stack the flitches on edge against the side supports.
3. Clamp the flitches against the side supports halfway up the flitch height.

Wider flitches should be placed to the clamp side. When they are edged, flip them over to edge the second side without disturbing the other flitches or without having to pull them from the middle of the stack.

4. Adjust the blade height to edge a few of the widest boards.
5. Loosen the clamps and turn the edged boards over to edge the other side.
6. Repeat steps 2-4.
7. Loosen the clamps and remove the boards that have good clean edges on both sides. Clamp the remaining flitches and repeat steps 2-5.

### 5.8 Blade Height Scale

See Figure 5-7.

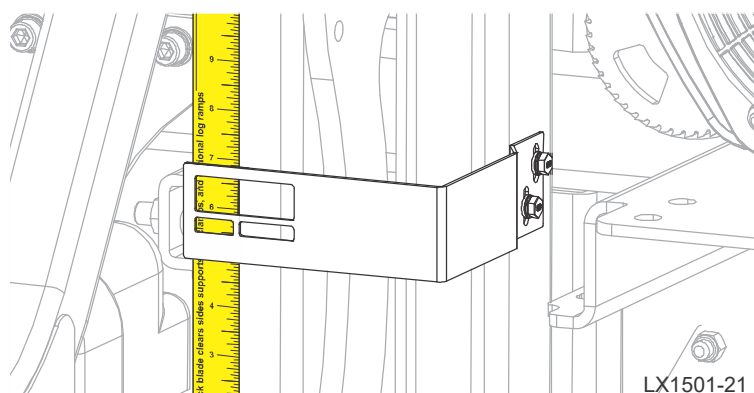

FIG. 5-7

#### THE INCH SCALE

The horizontal line on the blade height indicator shows how many inches the bottom of the blade is above the bed of the mill. If you know the height of your blade at each cut, you can determine the thickness of lumber you are sawing.

**Example:** You want to cut 1" (25 mm) random width boards from a log. Position the blade for the first cut. Move the mast to an even measurement on the inch scale. Make a trim cut. Return the mast for the second cut and lower it 1 1/8" (29 mm) below the original measurement. (The extra 1/8" (3 mm) allows for saw kerf and shrinkage of the lumber.)

**NOTICE:** The yellow area on the scale identifies where the blade could encounter a side support or log clamp. Check that these items are below the blade level before sawing.

### THE QUARTER SCALE

The magnetic quarter scale has four sets of marks. Each set represents a specific lumber thickness. Saw kerf and shrinkage allowance are included, but actual board thickness will vary slightly depending on blade thickness and tooth set.

See Table 5-1.

Standard Quarter Scale	
Scale	Actual Board Thickness
4/4	1" (25 mm)
5/4	1 1/4" (32 mm)
6/4	1 1/2" (38 mm)
8/4	2" (51 mm)

TABLE 5-1

To use the quarter scale, look at the blade height indicator.

Position the magnetic quarter scale over the inch scale. Align one of the quarter scale marks with the horizontal line on the indicator.

Make a trim cut. When you return the mast for a second cut, lower the mast to the next mark on the scale. This mark shows where the blade should be positioned to cut a certain thickness of lumber, without having to measure on the inch scale.

**Example:** You want to cut 1" (25 mm) (4/4) random width boards from a log. Position the blade for the first cut. Position the magnetic quarter scale so a 4/4 mark is aligned with the line on the indicator. Make a trim cut. Return the mast for the second cut. Now, instead of having to measure down 1 1/8" (29 mm) on the inch scale, you can simply lower the blade so the indicator is aligned with the next 4/4 mark on the quarter scale. Turn the log 90 degrees and repeat.

## 5.9 Water Lube Operation

The Water Lube System keeps the blade clean. Water flows from a 5-gallon (18.9 liter) bottle through a hose to the blade guide where the blade enters the log. A valve in the bottle cap controls the amount of water flow. Normal flow is 1-2 gallons (3.8-7.6 liters) per hour.

See Figure 5-8.

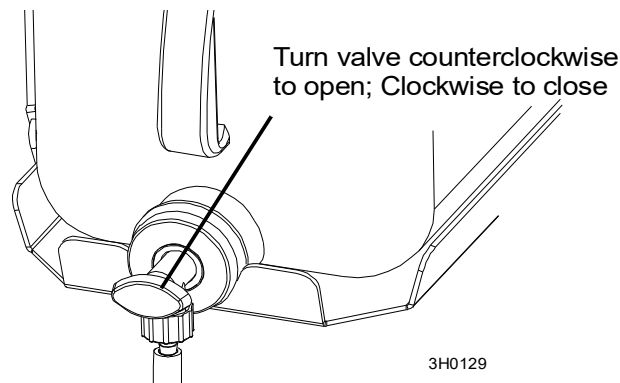

**FIG. 5-8**

Not all types of wood require the use of the Water Lube System. When it is needed, use just enough water to keep the blade clean. This saves water, and lowers the risk of staining the boards with water.

When changing blades, let the blade spin with water running on it for about 15 seconds before removing it. This will clean the blade of sap buildup. Dry blade with a rag before storing or sharpening.

For lubrication benefits, add one 12oz. (0.35L) bottle of Wood-Mizer Lube Additive to 5 gallons (18.9 liters) of water. Wood-Mizer Lube Additive enables some previously impossible timbers to be cut by significantly reducing resin buildup on the blade. It helps to reduce heat buildup, wavy cuts, and blade noise. This biodegradable and environmentally friendly pre-mix includes a water softener additive, so it works with hard water.

 **WARNING!** Do not use flammable fuels or liquids such as diesel fuel. Failure to follow this can damage the equipment and may result in serious injury or death.

Use **ONLY** water and Wood-Mizer Lube Additive with the water lube accessory. If these types of liquids are necessary to clean the blade, remove it and clean with a rag.

If you are sawing in freezing temperatures, remove the water lube bottle from the sawmill when done sawing and store it in a warm place. Blow any remaining water from the water lube hose.

## 5.10 Transporting the Sawmill



**WARNING!** Do not move the sawmill while fully assembled. Failure to follow this can damage the equipment and may result in serious injury or death.

If it is necessary to move the sawmill, it should be dismantled in a reverse order as described in the assembly procedures. Transportation should be done in the same configuration as originally shipped to the customer.

## SECTION 6 MAINTENANCE



**WARNING!** Turn the key switch to the OFF (0) position and remove the key before performing service near moving parts such as blades, pulleys, motors, belts, and chains. If the key is turned on and moving parts activated, serious injury or death may result.

Keep a log of machine maintenance by recording in the machine hours and the date you perform each procedure.

Refer to option and engine manuals for other maintenance procedures.

### 6.1 Wear Life

Due to the many variables which exist during sawmill operation, actual part life may vary significantly. This information is provided so that you may plan ahead in ordering replacement parts.

Part Description	Estimated Life
B57 Blade Wheel Belts	400 hours
Blade Guide Rollers	1000 hours
Drive Belt	1250 hours

### 6.2 Blade Guides



**WARNING!** Turn the key switch to the OFF (0) position and remove the key before performing service near moving parts such as blades, pulleys, motors, belts, and chains. If the key is turned on and moving parts activated, serious injury or death may result.

1. Check the rollers for performance and wear every blade change.
2. Replace any rollers which are not clean, not spinning freely, or have worn smooth or misshaped.



### 6.3 Changing The Blade

 **WARNING!** Turn the key switch to the OFF (0) position and remove the key before performing service near moving parts such as blades, pulleys, motors, belts, and chains. If the key is turned on and moving parts activated, serious injury or death may result.

Wear gloves and eye protection when handling bandsaw blades.

Keep all other persons away from area when coiling, carrying, or changing a blade. Changing blades is safest when done by one person.

1. Open the blade housing cover.
2. Turn the blade tension bar with the ratchet until the blade wheel is moved in.
3. Place the new blade around the blade wheels.

When installing a blade, make sure the teeth are pointing toward the operator side of the mill when you are looking at the blade below the blade guides.

4. Position 1 1/4" wide blades (standard) on the wheels so the gullet is 1/8" (3.0 mm) out from the edge of the wheel.
5. Close the blade housing cover.

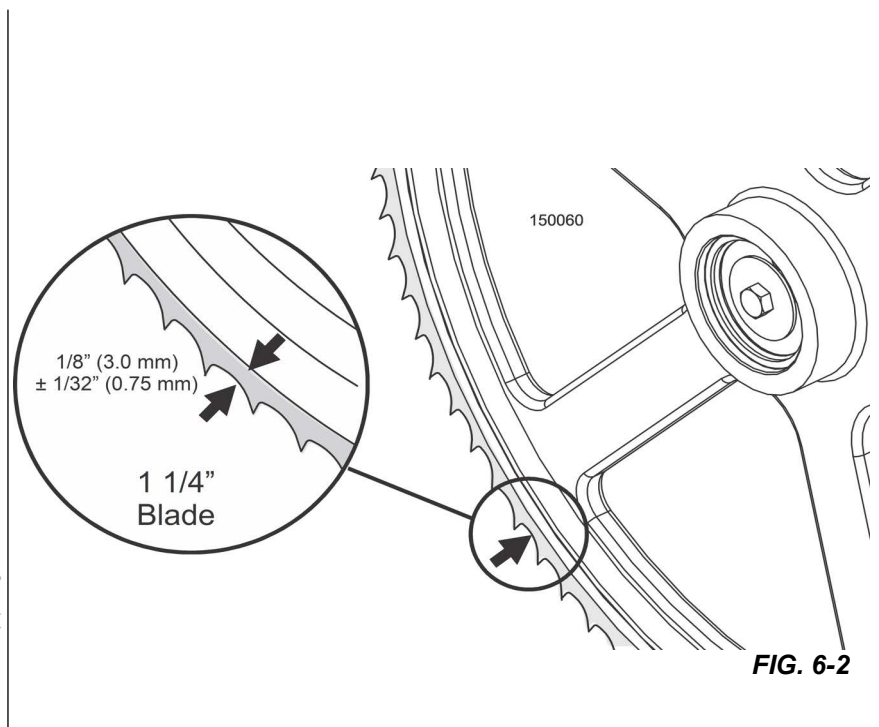
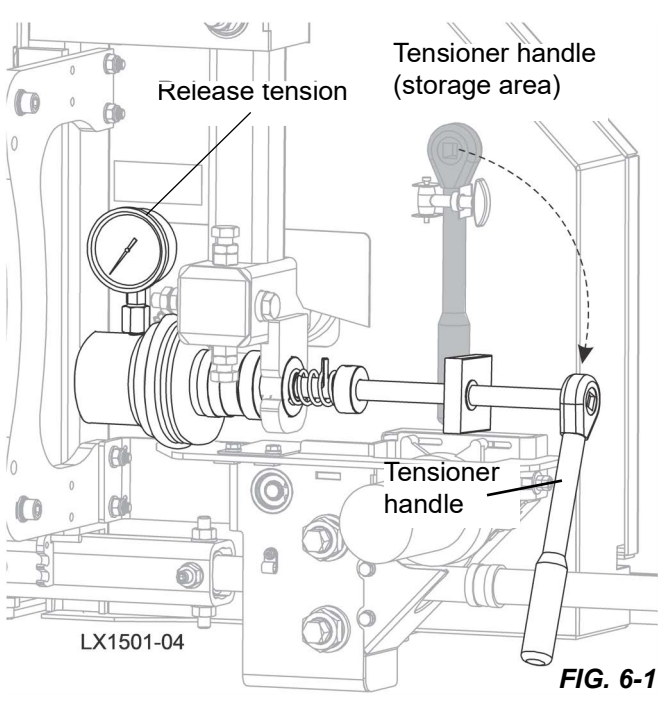

## 6.4 Add Oil to Tensioner Cylinder

As proper blade tension can no longer be maintained, the tensioner cylinder may need oil added.

1. Loosen the blade tensioner completely.
2. Unscrew the oil pressure gauge.

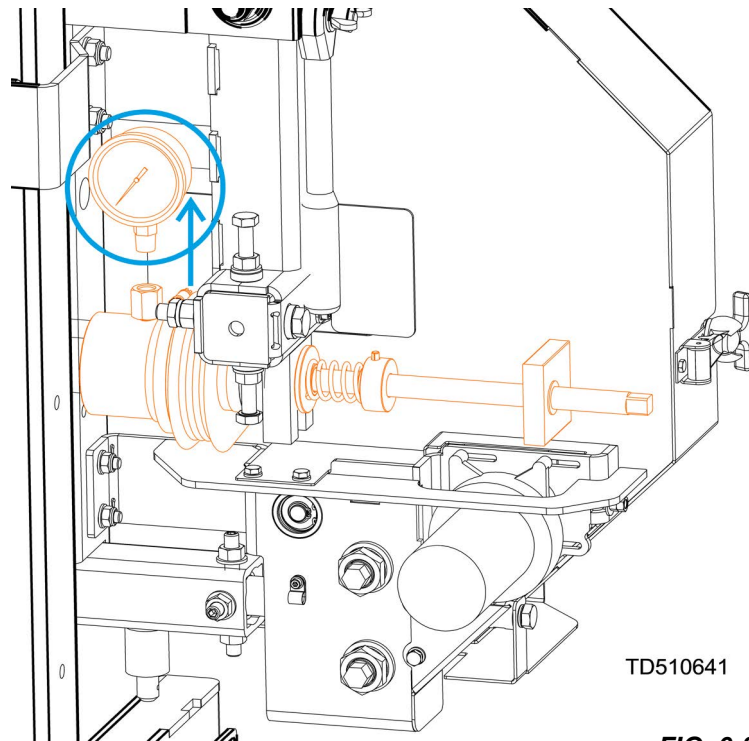

**FIG. 6-3**

3. Using an oiler equipped with a tube / hose, top up the oil level until the oil flows out of the cylinder.

**NOTICE** The cylinder needs to be filled with MOBIL DTE 10 Excel 32 Hydraulic Oil (#WM part number: P12825).

When topping up the oil level, make sure that the end of the oiler tube / hose is at the bottom of the cylinder.

4. Wait 5 minutes. If the oil level does not lower, move on to the next step. If the oil level lowers, top up the oil level until the oil flows out of the cylinder.

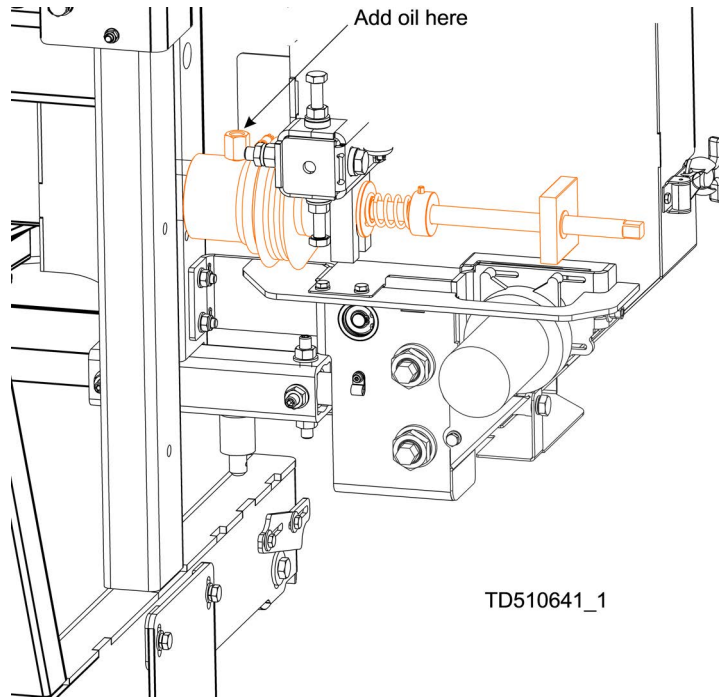

FIG. 6-4

5. Seal the oil pressure gauge with Teflon tape and screw it back.

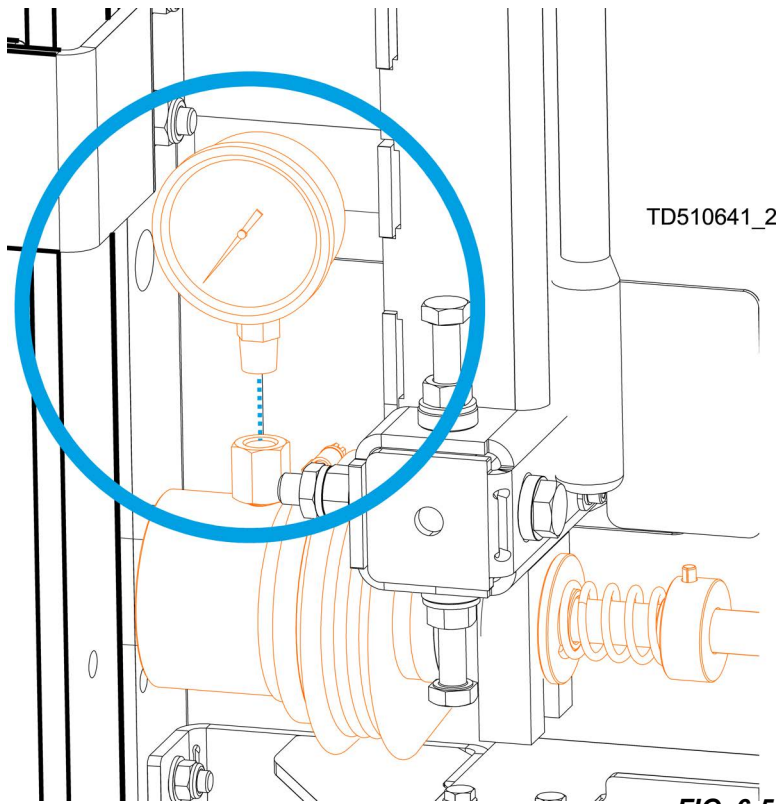

FIG. 6-5

## 6.5 Sawdust Removal



**WARNING!** Turn the key switch to the OFF (0) position and remove the key before performing service near moving parts such as blades, pulleys, motors, belts, and chains. If the key is turned on and moving parts activated, serious injury or death may result.

Remove the excess sawdust from the blade wheel housings and sawdust chute every blade change.



**WARNING!** Keep hands, feet and any other objects away from the sawdust chute when operating sawmill.

Ensure the steel fingers inside the sawdust chute are in place before operating the sawmill.

The steel fingers have been designed to help prevent a broken blade or some other object from becoming a projectile and exiting the sawdust chute.

Remove sawdust buildup from rope feed pulleys and up/down chain sprockets as necessary.

## 6.6 Mast Track, Wipers, & Scrapers



**WARNING!** Turn the key switch to the OFF (0) position and remove the key before performing service near moving parts such as blades, pulleys, motors, belts, and chains. If the key is turned on and moving parts activated, serious injury or death may result.

Properly maintaining the sawmill mast track is critical in preventing corrosion that can cause pitting and scaling on the rail surfaces. Pitted and scaled surfaces can, in turn, cause rough cuts or jerky feed movement.

1. Clean track rails to remove any sawdust and sap buildup every eight hours of operation.

Use a light-grade sandpaper or emery cloth to sand off any rust or other adhering particles from the rails.



**CAUTION!** Keep track rails free of rust. Formation of rust on the track rail in the areas where the cam bearings roll can cause rapid deterioration of the track rail's surface.

2. Lubricate the rails by wiping them with Dexron III ATF transmission fluid.

Lubrication will help protect the rails from corrosive elements such as acid rain and/or moisture from nearby bodies of saltwater (if applicable). This lubrication is essential to maintain the integrity of the track rails and track rollers and to achieve long service life.

3. Remove sawdust from the track roller housings and brush any sawdust buildup from the housings every twenty-five hours of operation.

4. Check the track scrapers (2 per track roller housing) for a firm fit against the rail.

If a track scraper needs to be adjusted, loosen the screw, push the scraper downward until it fits firmly against the rail, and retighten the screw.

## 6.7 Vertical Mast Rails



**WARNING!** Turn the key switch to the OFF (0) position and remove the key before performing service near moving parts such as blades, pulleys, motors, belts, and chains. If the key is turned on and moving parts activated, serious injury or death may result.

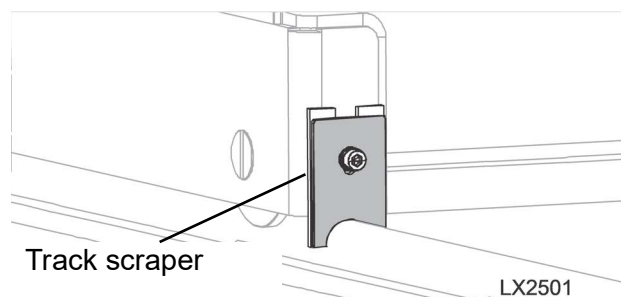

**FIG. 6-6**

Wipe the vertical mast rails with Dexron III ATF transmission fluid every 50 hours of operation.



**CAUTION!** Never use grease on the mast rails as it will collect sawdust.

## 6.8 Miscellaneous



**WARNING!** Turn the key switch to the OFF (0) position and remove the key before performing service near moving parts such as blades, pulleys, motors, belts, and chains. If the key is turned on and moving parts activated, serious injury or death may result.

1. Oil all chains with Dexron III ATF every fifty hours of operation.



**CAUTION!** Do not use chain lube. It causes sawdust buildup in chain links.

2. Grease the clamps and side support pivots with a NLGI No. 2 grade lithium grease every fifty hours of operation.
3. Check the mill alignment after every setup ([See Section SECTION 7](#)).
4. Make sure all safety warning decals are readable.

Remove sawdust and dirt covering warning decals. Replace any damaged or unreadable decals immediately. Order decals from your Customer Service Representative.

5. Replace the idle blade wheel belt as necessary. (Use only belts supplied by Wood-Mizer.)

## 6.9 Drive Belt Adjustment



**WARNING!** Turn the key switch to the OFF (0) position and remove the key before performing service near moving parts such as blades, pulleys, motors, belts, and chains. If the key is turned on and moving parts activated, serious injury or death may result.

For battery-powered equipment, disconnect the negative battery terminal cable. Failure to follow this may result in injury or death.

For electrical motors, disconnect and lockout power before performing any service to the electrical system. Failure to follow this may result in injury or death.

Do not adjust the engine drive belts or belt support bracket with the engine running. Doing so may result in serious injury or death.

See the table below for drive belt tension specifications. Measure the belt tension with a gauge, as shown in Fig 6-7.

New Belt Installation		
Check After	Deflection	Force
20 hrs	7/16" (11mm)	8 lbs. (3.63 kg)

Subsequent Adjustment		
Check Every	Deflection	Force
50 hrs	7/16" (11mm)	8 lbs. (3.63 kg)

### ADJUST THE DRIVE BELT TENSION

1. Use a belt tension gauge to measure the drive belt tension.
2. Zero out the pounds indicator by sliding the small o-ring against the yellow flange.
3. Open the access hole in the belt cover and place the tension gauge firmly against the belt.
4. Set the large o-ring even with the belt cover.
5. Add 1/2" (12.5mm) to that measurement and reset the large o-ring to the belt cover + 1/2" (12.5mm) setting.

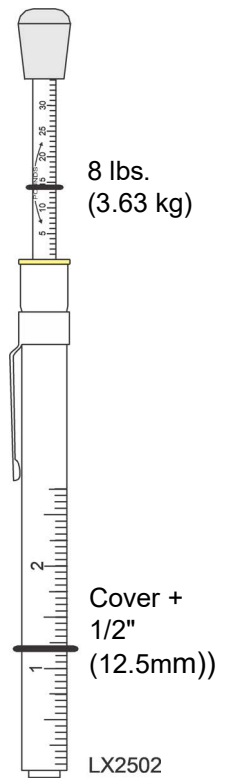

6. Press down on the rubber boot; stop pressing when the large o-ring meets the edge of the belt cover.
7. Read the pounds indicated by the small O-ring; it should read 8 lbs (3.63 kg).

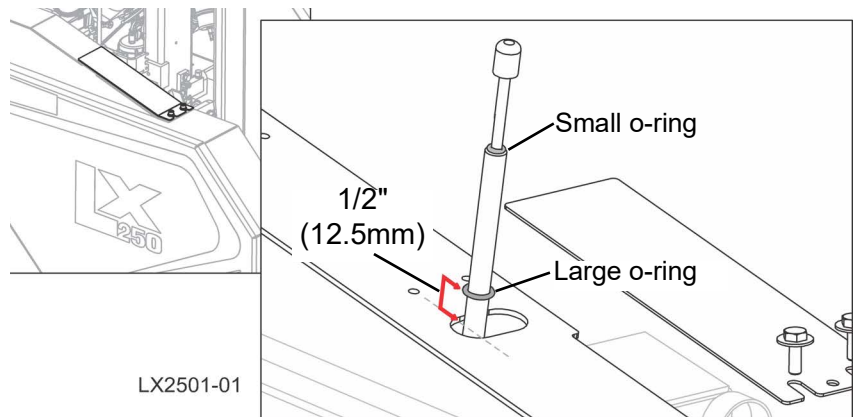

FIG. 6-7

8. If the reading is too high or low, use the clutch cable adjustment nuts to correct the tension.

### 6.10 Up/Down System



**WARNING!** Turn the key switch to the OFF (0) position and remove the key before performing service near moving parts such as blades, pulleys, motors, belts, and chains. If the key is turned on and moving parts activated, serious injury or death may result.

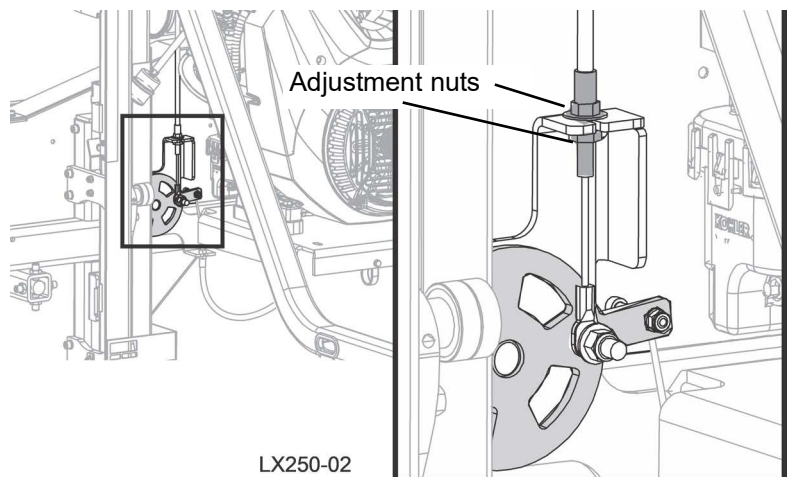
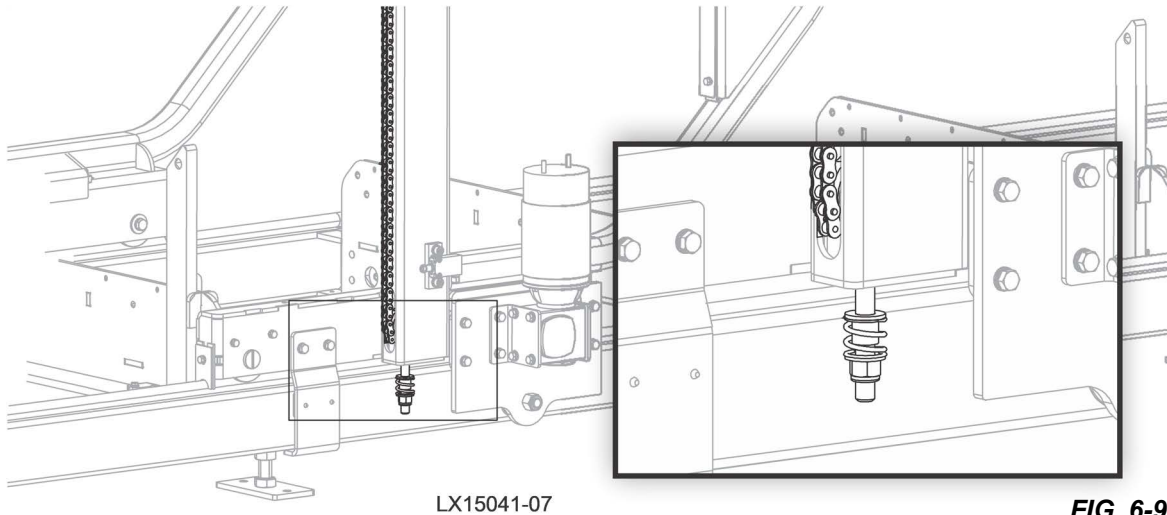

FIG. 6-8

### ADJUST THE UP/DOWN CHAIN AS NEEDED.

The up/down chain is adjusted to level the sawhead.

1. Locate the chain adjusting bolt at the bottom of the mast.
2. Loosen the adjustment nut provided on the bottom of the sprocket assembly and move the sprocket up/down until the saw-head is level.
3. Repeat on the other side as necessary.



## 6.11 Charging The Battery



**WARNING!** Turn the key switch to the OFF (0) position and remove the key before performing service near moving parts such as blades, pulleys, motors, belts, and chains. If the key is turned on and moving parts activated, serious injury or death may result.

Batteries expel explosive gases; keep sparks, flames, burning cigarettes, or other ignition sources away at all times.

Always wear safety goggles and a face shield when working near batteries.

Wash hands after handling batteries to remove possible lead, acid, or other contaminants.

Charge the battery in a well ventilated area.

Do not attempt to charge a frozen battery.

**NOTICE:** When working with batteries, use extreme care to avoid spilling or splashing electrolyte (dilute sulfuric acid) as it can destroy clothing and burn the skin.

**EMERGENCY TREATMENT FOR CONTACT WITH BATTERY COMPONENTS (LEAD/SULFURIC ACID) per SDS (Safety Data Sheet):**

<b>EYE CONTACT</b>	<b>Sulfuric Acid and Lead:</b> Flush eyes immediately with large amounts of water for at least 15 minutes while lifting lids. Seek immediate medical attention if eyes have been exposed directly to acid.
<b>SKIN CONTACT</b>	<b>Sulfuric Acid:</b> Flush affected area(s) with large amounts of water using deluge emergency shower, if available, shower for at least 15 minutes. Remove contaminated clothing, including shoes. If symptoms persist, seek medical attention. Wash contaminated clothing before reuse. Discard contaminated shoes. <b>Lead:</b> Wash immediately with soap and water.
<b>INGESTION</b>	<b>Sulfuric Acid:</b> Administer large amounts of water. Do NOT induce vomiting or aspiration into the lungs may occur and can cause permanent injury or death; consult physician.
<b>INHALATION</b>	<b>Sulfuric Acid:</b> Remove to fresh air immediately. If not breathing, give artificial respiration. If breathing is difficult, give oxygen. Consult a physician. <b>Lead:</b> Remove from exposure, gargle, wash nose and lips; consult physician.



**CAUTION!** Do not overcharge the battery. Overcharging may reduce the overall service life of the battery.

Be sure the battery is fully charged before transporting the sawmill. If the battery is not fully charged, excessive vibration could reduce the overall service life of the battery.

1. Turn the key to the OFF (0) position and remove the key.
2. Remove the battery box lid.
3. Clean the battery terminals, if necessary.
4. Connect the positive charger/jumper cable directly to the positive battery terminal.
5. Connect the negative charger/jumper cable to a grounded metal surface.
6. Follow the instructions supplied with your specific battery charger.

**NOTICE** Be careful not to overcharge the battery, especially when using a high-rate or “boost” charger (40 amps or higher). These are intended to quickly charge a good battery that is discharged. They are not intended for unattended or long-term charging.

7. After the battery is completely recharged, remove the negative charger/jumper cable from ground.
8. Remove the positive charger/jumper cable from the battery.
9. Replace the battery box lid.



## SECTION 7 TROUBLESHOOTING GUIDE

### 7.1 Sawing Problems



**WARNING!** Turn the key switch to the OFF (0) position and remove the key before performing service near moving parts such as blades, pulleys, motors, belts, and chains. If the key is turned on and moving parts activated, serious injury or death may result.

PROBLEM	CAUSE	SOLUTION
<b>Blades Dull Quickly</b>	Dirty logs	Clean or debark logs, especially on entry side of the cut
	When grinding teeth, heating too much and causing teeth to soften	Grind just enough metal to restore sharpness to the teeth. Use water/coolant while sharpening blade
	Poor sharpening techniques	Make sure the tip is being sharpened completely: Read the instructions with your blade sharpening equipment carefully
<b>Blades break prematurely</b>	Poor sharpening techniques	Read the instructions with your blade sharpening equipment carefully
	Rubber belts on idle blade wheel worn to a point that blade contacts metal pulley - look for shiny spots on edge of wheels	Change idle blade wheel belts
	Tension too tight	Tension blade to recommended specifications
<b>Blade does not track right on drive wheel</b>	Cant adjustment is incorrect	Readjust
<b>Blade guides do not spin while cutting</b>	Frozen bearings	Replace bearings
<b>Drive belts wear prematurely or jump</b>	Engine/motor and drive pulleys out of alignment	Align pulleys
<b>Boards thick or thin on ends or middle of board.</b>	Stress in log which causes log to not lay flat on the bed.	After log has been squared, take equal cuts off opposing sides. Take a board off the top. Turn the log 180 degrees. Take a board off. Repeat, keeping the heart in the middle of the cant, and making it your last cut.
	Set in teeth.	Resharpen and reset blade.
	Bed rails misaligned.	Realign sawmill bed.
<b>Height adjustment jumps or stutters when moving up or down.</b>	Up/down chain improperly adjusted.	Adjust up/down chain.
	Vertical wear pads are too tight.	Adjust pads.
<b>Lumber is not square</b>	Vertical side supports not square to bed	Adjust side supports.
	Blade not parallel to bed rails	Adjust bed rails parallel to blade.
	Sawdust or bark between cant and bed rails	Remove particles
	Tooth set problems	Resharpen and reset blade
<b>Sawdust builds up on track</b>	Excessive oiling	Do not oil track
	Track wipers worn	Adjust wipers to firmly contact track
	Track is sticky	Clean track with solvent and apply silicone spray
<b>Wavy cuts</b>	Excessive feed	Slow feed rate

PROBLEM	CAUSE	SOLUTION
	Improperly sharpened blade (This will be the problem 99% of the time!)	Resharpener blade, following the sharpener's instructions carefully
	Blade guides improperly adjusted	Adjust blade guides.
	Sap buildup on blade	Use Water Lube.
	Tooth set problem	Resharpener and reset blade

## 8.2 Simple Set Troubleshooting

### Error Messages

See **Table 8-1**. Simple Set error messages.

Error	Description
E02 Sensor	This message is displayed if Simple Set cannot detect the encoder sensor magnet when entering auto mode. Check that the gear box extension is aligned with the sensor. Push any button on the Simple Set control to exit to manual mode.
E03 Sensor	This message is displayed if Simple Set cannot detect a signal from the encoder sensor when entering auto mode. Check the encoder sensor cable connections. push any button on the Simple Set control to exit to manual mode.

TABLE 8-0

### Diagnostic Lights

LED indicator lights are provided on the encoder sensor housing, the display circuit board, and H-bridge module inside the Simple Set control box. Observe the LED lights during operation to identify problems with the sensor, drum switches, or Simple Set control.

See **Figure 8-1**.

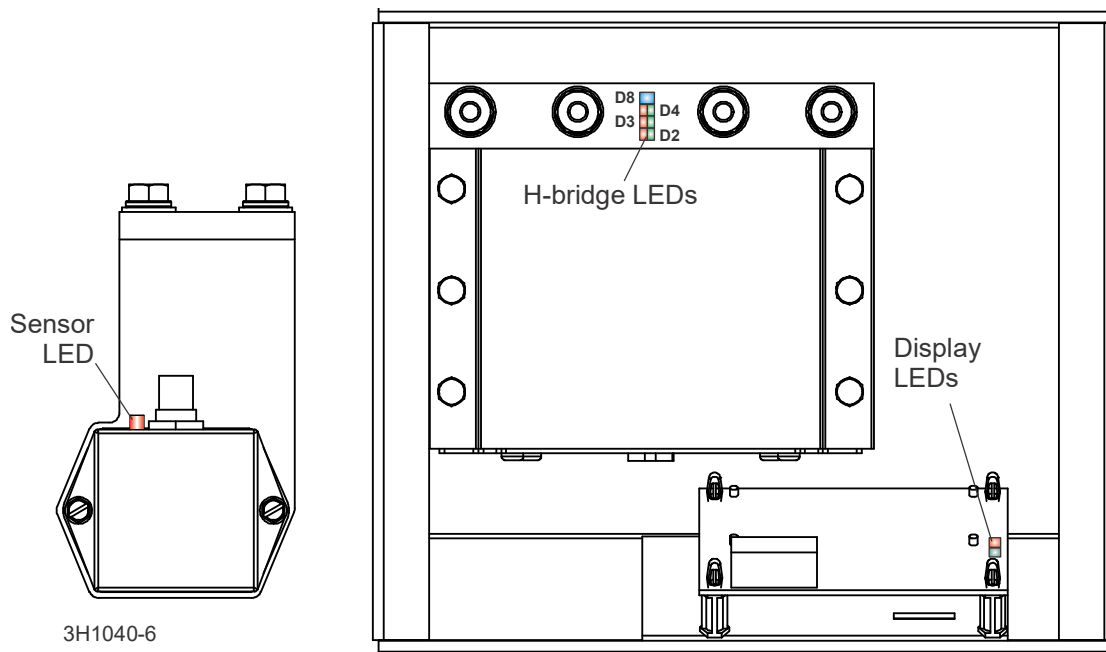

FIG. 8-1

**NORMAL OPERATION:**

- As the up/down gearbox shaft spins to move the saw head up or down, the sensor LED will illuminate and brighten. After each complete revolution of the shaft, the LED will turn off, then illuminate and brighten.





**MANUAL MODE**

- In manual mode, the control board LED and the H-bridge D2, D3, D4 LEDs will illuminate (red) when the drum switch is activated in the down direction and (green) when the up/down drum switch is activated in the up direction. The LEDs will turn off when the drum switch is released. The H-bridge D8 LED will illuminate blue to indicate the 5 Volt DC output to the control board.

**AUTO MODE**

- In auto mode, the control box LED and the H-bridge D2, D3, D4 LEDs will illuminate (green) in the up direction as in manual mode. When the drum switch is bumped in the down direction, the control box LED and the H-bridge D2, D3, D4 LED's will illuminate (red) in the down direction but the control board LED will immediately turn off. When the blade reaches the increment value set by the Simple Set control, the D2, D3, D4 LEDs on the H-bridge will turn off. If the drum switch is held down or the saw head coasts past the increment, the H-bridge D2, D3, D4 LEDs will illuminate (green) indicating the blade will move up to return to the increment value. When the blade reaches the increment value, the H-bridge D2, D3, D4 LEDs will turn off.

**Simple Set Up/Down Gear Settings Adjustment**

1. Make sure the power to the control box is on.
2. Press and hold the Manual  button and then press and hold the UP  button
3. Release the Manual  button, then release the UP  button

The Simple Set control panel will display the Speed setting.

See Figure 8-2.

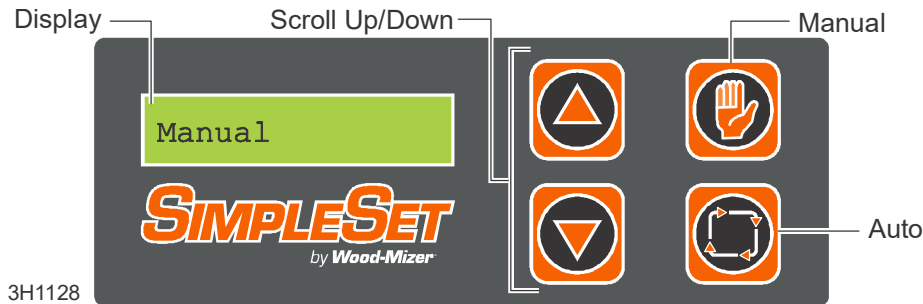









FIG. 8-2



4. Press the Auto  button several times until "Gear: 0.xxxx" appears.
5. Use the Up  /Down  buttons to set the value of the Gear Setting as shown in the table below.



Models	Revision	Gear Setting	InvGear Setting
LT40 (Default)	All	0.0938 (Default)	No (Default)
LT35/LT35HD	A5.00+ (or any revision upgraded with Up/Down Kit 074316)	0.1170	No
LX150	A1.00+	0.1350	Yes

TABLE 8-0

6. Press the Auto  button to display "InvGear: xx".
7. Use the Up  /Down  buttons to set the InvGear setting to the required value as shown in the table above.
8. Press the Manual  button to return to the main menu.

### Simple Set PID Settings

1. Make sure the power to the control box is on.
2. Press and hold the Manual  button and then press and hold the UP  button.

3. Release the Manual  button, then release the UP  button.

The Simple Set control panel will display the Speed setting.

See Figure 8-3.

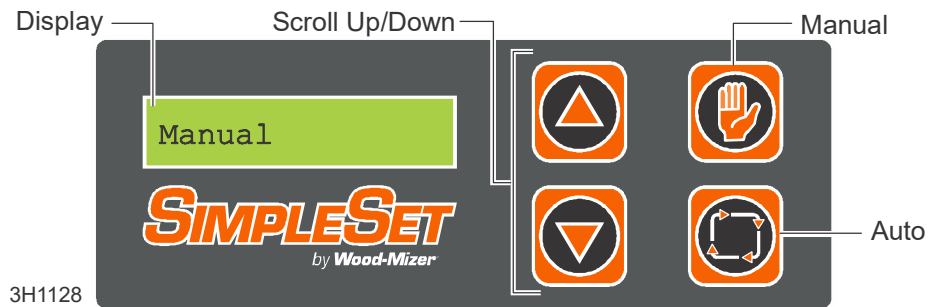





FIG. 8-3

4. Press the Auto  button several times until PGain, DGain and IGain settings appear.
5. Use the Up  /Down  buttons to set the settings to the required values.



**IMPORTANT!** The PID settings are factory-set and they should not be changed. If necessary, set the PID settings to the following values: PGain 1.0, DGain 0.0 and IGain 0.0.

6. Press the Manual  button to return to the main menu.

## SECTION 9 SAWMILL ALIGNMENT

Two alignment procedures are available to realign the sawmill if necessary. The Routine Alignment instructions should be performed as necessary to solve sawing problems not related to blade performance. The Complete Alignment procedure should be performed approximately every 1500 hours of operation.

**THE PROCURES LISTED HERE MUST BE PERFORMED IN THE ORDER THEY APPEAR.**

### 9.1 Routine Alignment Procedure

Prepare the sawmill for alignment.

Adjust the blade parallel to the bed rails.

Adjust the blade guide arm parallel to the saw head main tube.

Align blade guide arm parallel to the blade.

Adjust side supports square to the bed.

Final adjustments.

#### ***Prepare the sawmill for alignment.***

Before performing the setup procedures from Section 3: setup the mill on firm, level ground, level the bed, and adjust the legs so the entire frame is level.

#### **BLADE REPLACEMENT**

1. Remove the blade and check the blade wheel belts.
2. Remove any sawdust buildup from the surface of the belts.
3. Replace worn belts if they do not keep the blade from contacting the blade wheel.
4. Perform subsections [4.1 Tensioning the Blade](#), and [4.3 Tracking the Blade](#).

#### ***Saw Head Tilt***

If slabs are not square and have a taper along the length of one side, adjust the saw head tilt.

1. Move the saw carriage so the blade is positioned over a bed rail. Adjust the blade guide arm to 1/2" (15 mm) from full open.
2. Raise the saw head so the bottom of the blade measures 14 3/4" (375 mm) from the top surface of the bed rail near the inner blade guide assembly.
3. Measure from the blade to the bed rail near the outer blade guide assembly. This measurement must be equal to the inner measurement of 14 3/4" (375 mm).

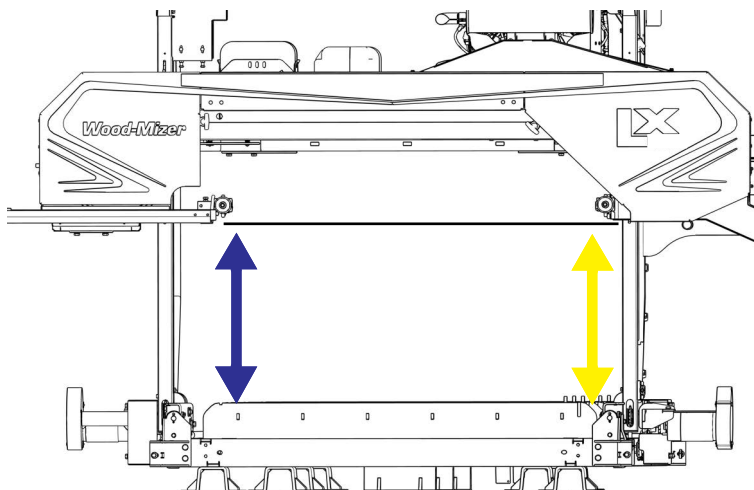

TDLX250G38

**FIG. 9-1**

If the measurements are not equal, adjust the saw head tilt.

4. Loosen (2) pillow block bolts on the inside of engine-side upright.
5. Turn the vertical tilt adjustment bolt to tilt saw head as needed.
6. Repeat two measurements from blade to bed.
7. Once the measurements are equal, tighten pillow block bolts.

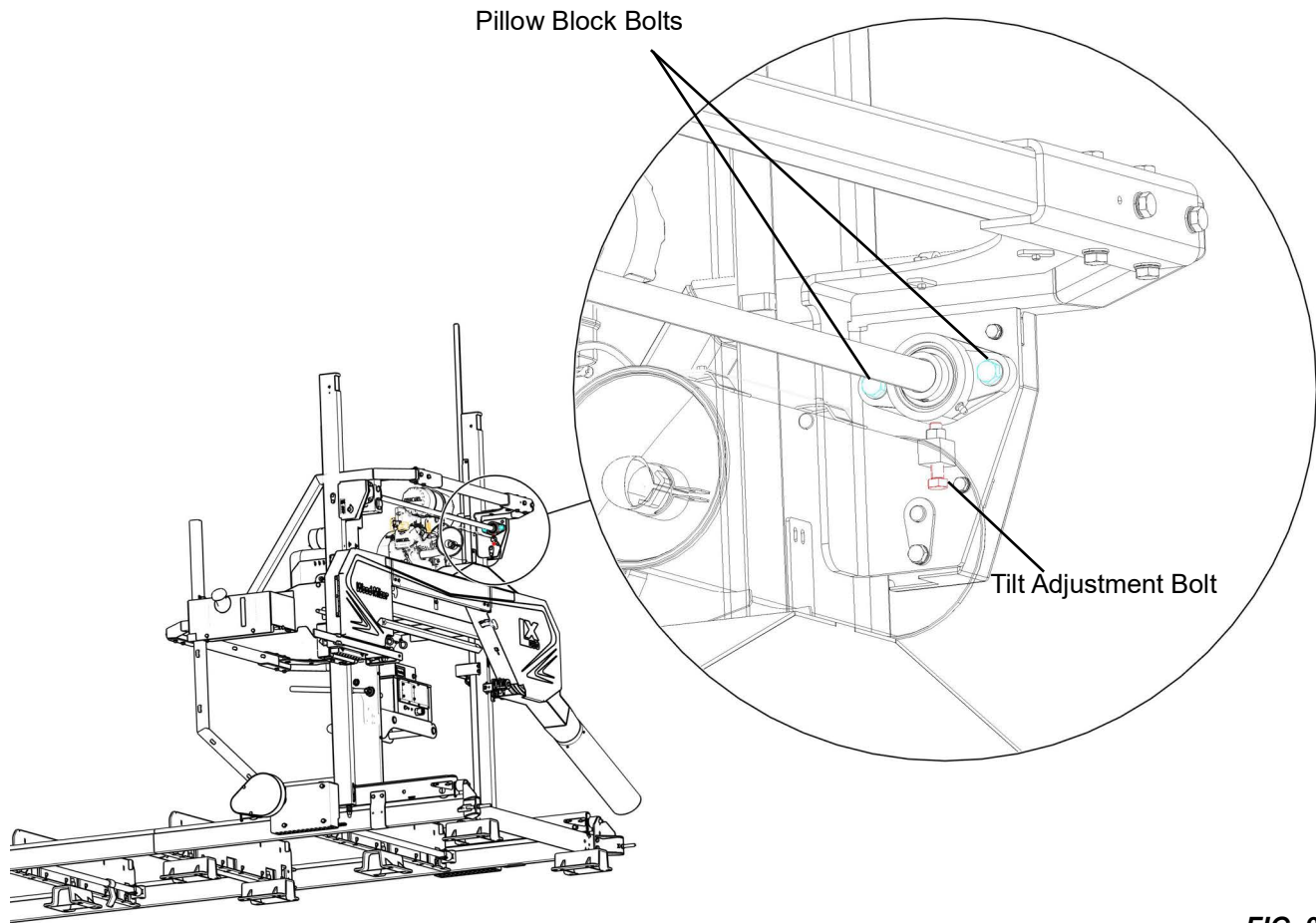

TDLX250G38\_1

**FIG. 9-2**

### **Blade Guide Arm Alignment**

The blade guide arm moves the outer blade guide in and out. If the arm becomes loose, the blade guide will not deflect the blade properly, causing inaccurate cuts. A loose blade guide arm can also cause blade vibration.

1. Remove the front cover from the blade guide arm assembly (4 bolt on front).
2. Remove the bottom cover (2 nuts and 2 flat washers).
3. Open the sawhead door to gain access to the rear nuts of the 4 blade arm roller assemblies.



### BLADE GUIDE ARM VERTICALLY (PARALLEL TO THE SAW HEAD MAIN TUBE)

4. Adjust the blade guide arm to within 1/2" (13 mm) of fully retracted (blue/right position in Figure 9-3).
5. Measure the distance between the sawhead main tube and the blade guide arm. See Fig. 9-3.
6. Fully extend the blade guide arm.
7. Measure the distance between the sawhead main tube and the blade guide arm. See Fig. 9-3.
8. Adjust the blade guide arm until the two measurements are the same.

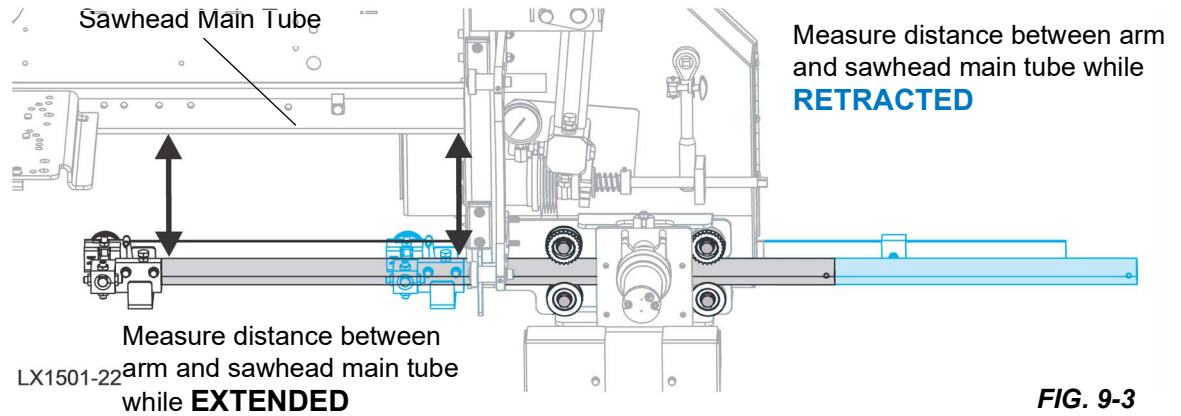

**NOTE:** Start with the upper/lower roller assemblies on one side and move to the other if necessary.

The eccentric nut provides fine adjustments. Multiple trials may be needed to obtain the proper alignment.

- a. Loosen (do not remove) the nut inside the sawhead frame.
- b. Loosen the nut between the sawhead frame and the grooved rollers.
- c. Turn the eccentric nut until the roller has move the appropriate distance.
- d. Tighten the nut inside the sawhead frame.
- e. Tighten the nut between the sawhead frame and the grooved rollers.

**Sawhead frame members remove for illustration purposes only.**

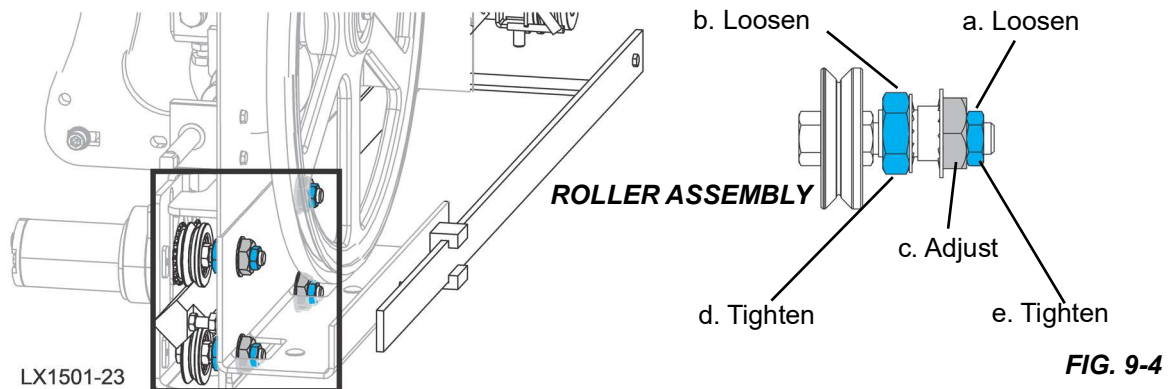

### BLADE GUIDE ARM HORIZONTALLY (PARALLEL TO THE BLADE)

9. Fully extend the blade guide arm. See Fig.9-3.
10. Measure the distance between the blade and the blade guide arm near the blade guide.
11. Measure the distance between the blade and the blade guide arm near the sawhead frame.

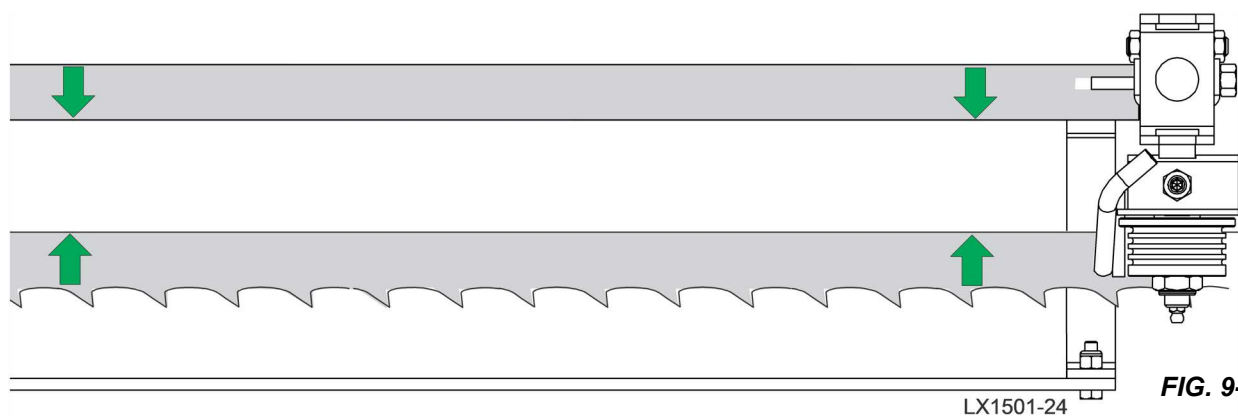

12. Adjust the blade guide arm until the two measurements are the same.

**NOTE:** Start with the upper/lower roller assemblies on one side and move to the other if necessary.

Multiple trials may be needed to obtain the proper alignment.

- a. Loosen (do not remove) the nut inside the sawhead frame.
- b. Adjust the roller assembly bolt (loosen/tighten as necessary) on the end of the roller assembly.
- c. Move the rollers the appropriate distance in or out until the measurements are the same.
- d. Tighten the nut inside the sawhead.

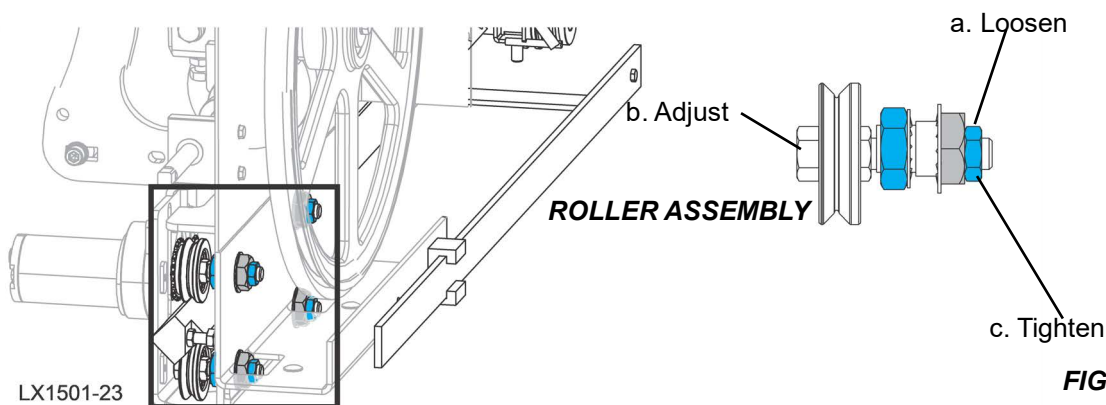

**NOTICE:** Check the alignment of the blade guide arm drive motor sprocket with the roller sprockets. If your adjustments of the rollers misaligns the drive sprockets, loosen the motor mount bolts (located on the bottom of the mounting bracket) and move in or out as needed. Tighten the bolts.

13. Reassemble all blade guide arm covers removed in steps 1 and 2 of this section.

### **Blade Guide Vertical Tilt Alignment**

The blade guides should be adjusted properly in the vertical plane. If the blade guides are tilted vertically, the blade will try to travel in the tilted direction.

A Blade Guide Alignment Tool (BGAT) is provided to help you measure the vertical tilt of the blade.

14. Open the blade guide arm to within 1/2" (13 mm) of fully open.

15. Clip the alignment tool on the blade.

**NOTICE:** Position the tool close to the outer blade guide assembly. Be sure the tool does not rest on a tooth or burr, and is lying flat against the bottom of the blade.

16. Move the mast so that the front end of the tool is positioned above the bed rail.
17. Measure the distance from the bed rail to the bottom edge of the tool.
18. Move the mast so that the back end of the tool is positioned above the bed rail.
19. Measure the distance from the bed rail to the bottom edge of the tool.

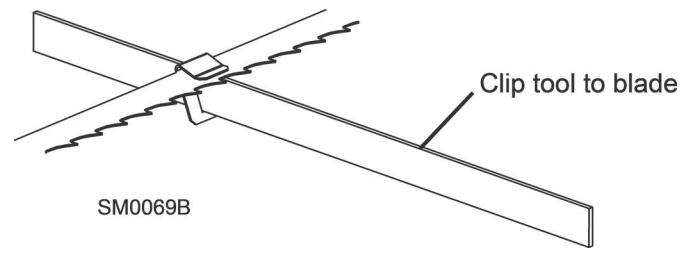

FIG. 9-7

20. If the measurement from the tool to the bed rail is not equal within 1/32" (.75 mm), adjust the vertical tilt of the outer blade guide roller.

21. Loosen one set screw at the side of the blade guide assembly.
22. Loosen the jam nuts on the top and bottom vertical tilt adjustment screws.

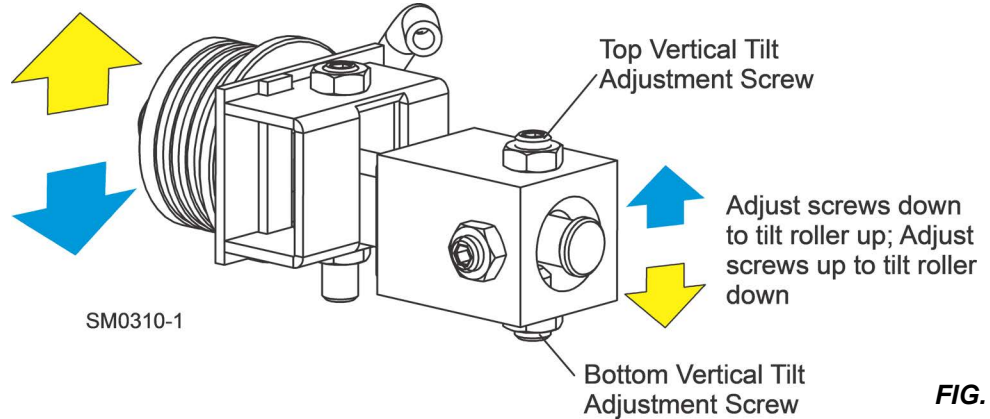

FIG. 9-8

To tilt the roller up, loosen the bottom screw and tighten top screw. To tilt the roller down, loosen the top screw and tighten the bottom screw.

23. Tighten the jam nuts and recheck the tilt of the blade.

24. Move the blade guide alignment tool close to the inner blade guide roller assembly and repeat the above steps.

25. Adjust the vertical tilt of the inner blade guide, if necessary.

### Blade Guide Horizontal Tilt Adjustment

If the blade guides are tilted in the wrong direction horizontally, the back of the blade may contact the flange as the roller is spinning down, causing it to push the blade away from the guide roller.

1. Remove the blade guide alignment tool from the blade and adjust the blade guide arm halfway in.

2. Measure between the back edge of the blade and the blade guide roller at the left side of the blade guide ("A").

3. Measure between the back edge of the blade and the blade guide roller at the right side of the blade guide ("B").

The roller should be tilted slightly to the left ('A' 1/8" [3 mm] less than 'B' ±1/8" [3 mm]).

4. Loosen the jam nuts on the horizontal tilt adjustment screws.

To tilt the roller left, loosen the right screw and tighten left screw. To tilt the roller right, loosen the left screw and tighten the right screw.

5. Tighten the jam nuts and recheck the tilt of the blade

6. Repeat the above steps for the other blade guide roller assembly.

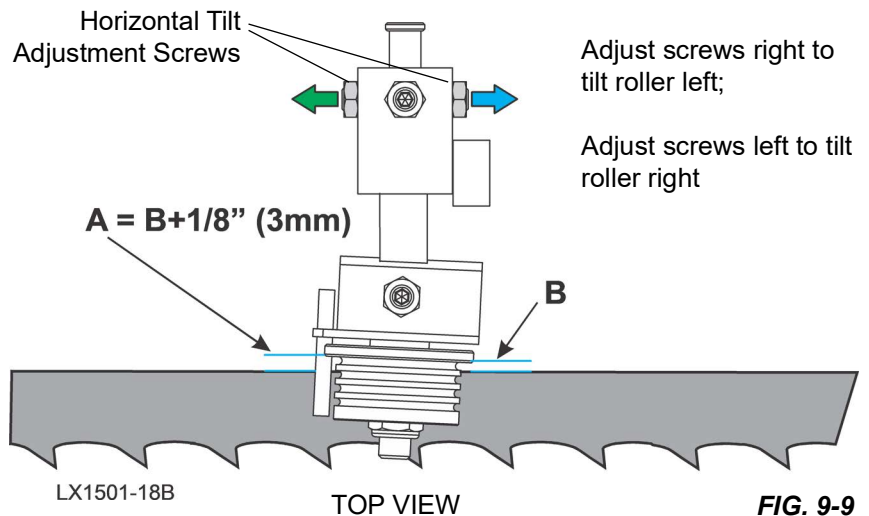

FIG. 9-9

### Blade Guide Flange Spacing

Each blade guide must be adjusted so the roller flange is the correct distance from the back edge of the blade. If the flange is too close to or too far from the blade, the sawmill will not cut accurately.

**NOTICE:** When adjusting blade guide spacing, loosen the top set screw and one side set screw only. This will ensure horizontal and vertical tilt adjustments are maintained when the adjustment screws are retightened.

### OUTER BLADE GUIDE

1. Ensure that the distance between the flange on the outer blade guide roller to the back edge of the blade measures to 1/8" (3.0 mm).
2. Adjust the roller back or forward if necessary.

3. Loosen the top screw and one side screw.

4. Gently tap the blade guide forward or backward until properly positioned.

5. Retighten the screws and jam nuts.

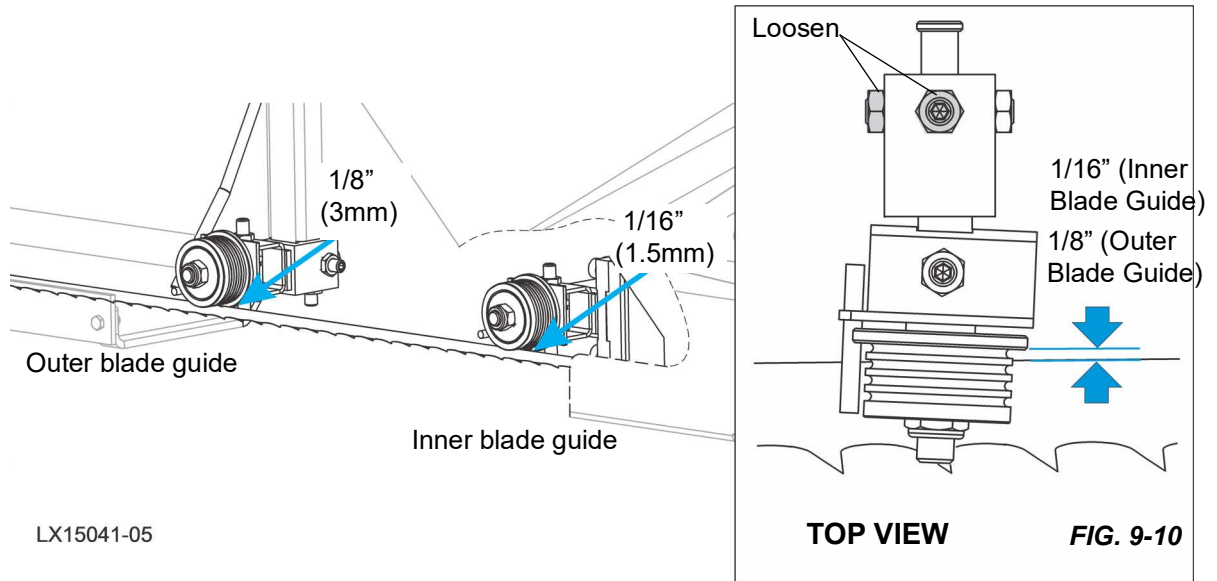

### INNER BLADE GUIDE

6. Ensure that the distance between the flange on the outer blade guide roller to the back edge of the blade measures to 1/16" (1.5 mm).

LX15041-05

7. Adjust the roller back or forward, as described above.

**NOTE:** Once the blade guides have been adjusted, any cutting variances are most likely caused by the blade. [See Blade Handbook, Form #600.](#)

### Blade Height Scale Adjustment

After the entire sawmill has been aligned and all adjustments made, check that the blade height scale indicates the true distance from the blade to the bed rails.

1. Move the saw mast so the blade is positioned directly above one of the bed rails.
2. Measure from the bottom edge on a down-set tooth of the blade to the top of the bed rail, near the inner blade guide assembly.

If the scale does not indicate the actual distance from the blade to the bed rail when viewed level at the indicator, adjust the indicator.

3. Loosen the indicator bracket mounting screws.
4. Adjust the bracket up or down until the indicator is aligned with the correct mark on the scale (+0 -1/32 [0.8 mm]).
5. Retighten the indicator mounting screws.

For example, if the measurement from the down-set tooth of the blade to the bed rail was 14 3/4" (375 mm), make sure the indicator reads 14 3/4" (375 mm) on the scale.

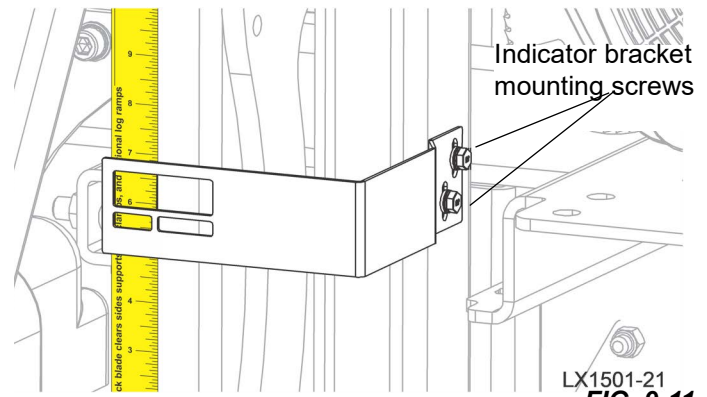

## 9.2 Complete Alignment Procedure

The Complete Alignment procedure should be performed approximately every 1500 hours of operation (sooner if you regularly transport the sawmill over rough terrain).

**NOTICE:** The alignment procedures should be done in the order listed here, as each procedure builds on the previous procedure.

### Frame Setup

Before performing the following alignment procedures, setup the mill on firm, level ground.

Level the frame and adjust the saw head.

### Complete Blade Replacement

1. Open the sawhead and remove the saw blade.
2. Replace the blade wheel belts.

**NOTE:** New blade wheel belts are required to perform the complete alignment procedure.

3. Blow sawdust off of the blade guide assemblies and blade housings.
4. Remove the blade guide assemblies.

**NOTE:** To remove the blade guide assemblies and maintain the tilt adjustments, only loosen one side screw and the top screw. Leaving the other side screw and bottom screw in position will insure you will return the rollers to their original tilt adjustment.

5. Adjust the outer blade guide arm until the outer blade guide is approximately 24" from the inner blade guide.
6. Install a new blade and apply the appropriate tension.
7. Close the blade housing covers and make sure all persons are clear of the saw head.
8. Start the engine.
9. Engage the blade momentarily, rotating the blade until the blade positions itself on the wheels.



**WARNING!** Do not spin the blade wheels by hand. Spinning the blade wheels by hand may result in serious injury.

10. Disengage the blade.
11. Turn the engine off.

### Blade Wheel Alignment

The blade wheels should be adjusted so they are level in the vertical and horizontal planes. If the blade wheels are tilted up or down, the blade will want to cut in the tilted direction. If the blade wheels are tilted horizontally, the blade will not track properly on the wheels.

## DRIVE-SIDE BLADE WHEEL

1. Attach the Blade Guide Alignment Tool (p/n LTBGAT) to the blade as close to the wheel as possible without anything interfering with the tool.

**NOTICE:** Be sure the tool does not rest on a tooth or burr, and is lying flat against the bottom of the blade.

2. Move the saw mast so the front end of the tool is positioned over the first bed rail.
3. Measure from the bottom of the tool to the top surface of the bed rail.
4. Move the saw mast so the rear of the tool is positioned over the bed rail.
5. Measure from the bottom of the tool to the top surface of the bed rail.
6. If the two measurements differ by more than 1/16" (1.5 mm), adjust the vertical tilt of the drive-side blade wheel.

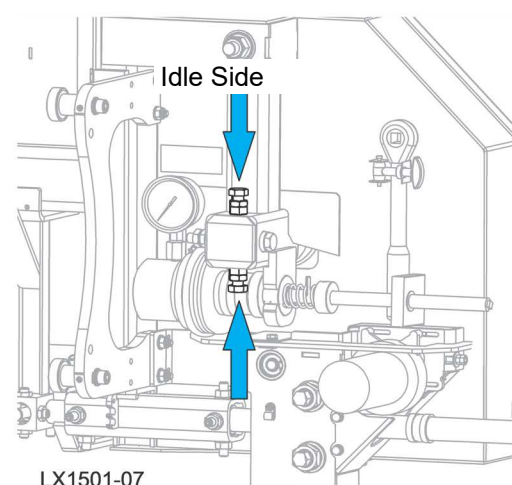
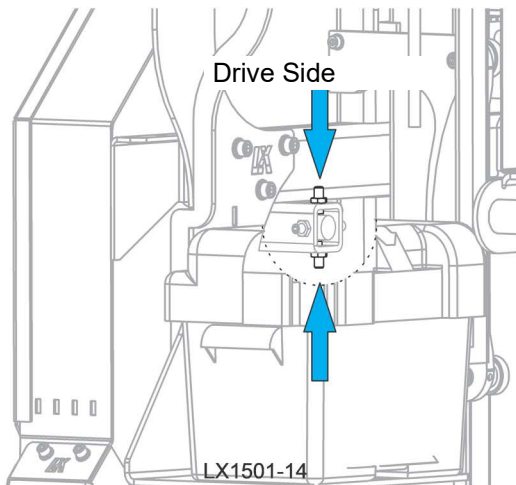
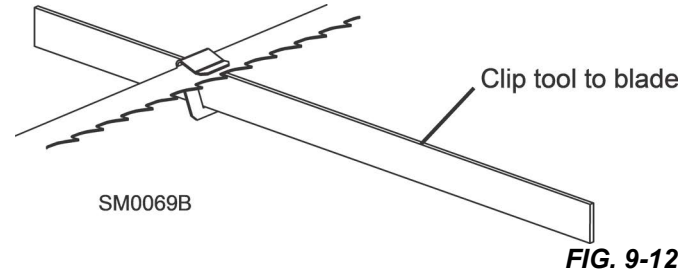

**FIG. 9-13**

7. Use the vertical adjustment screws to adjust the drive-side blade wheel.
  - 1). To tilt the wheel down, loosen the top adjustment screw one quarter turn.
  - 2). Loosen the jam nut on the bottom adjustment screw and tighten the screw.
  - 3). Tighten the top and bottom jam nuts.
  - 4). To tilt the wheel up, loosen the bottom adjustment screw one quarter turn.
  - 5). Loosen the jam nut on the top adjustment screw and tighten the screw.
  - 6). Tighten the top and bottom jam nuts
8. Recheck the vertical tilt of the drive-side blade wheel with the blade guide alignment tool.
9. Readjust the blade wheel as necessary until the front and rear of the tool are the same distance from the bed rail (within 1/16" [1.5 mm]).

## IDLE-SIDE BLADE WHEEL

1. Move the blade guild arm fully to the right.
2. Remove the tool from the blade and reattach it as close to the idle-side wheel as possible without anything interfering with the tool.

3. Measure from the tool to the bed rail at both ends of the tool.
4. If the measurements at the front and rear ends of the tool differ by more than 1/16" (1.5 mm), adjust the vertical tilt of the idle-side blade wheel in the same manner as in Step 7.
5. Recheck the vertical tilt of the idle-side blade wheel with the blade guide alignment tool. Readjust the blade wheel as necessary until the front and rear of the tool are the same distance from the bed rail (within 1/16" [1.5 mm]).

### BLADE TRACKING

6. Check the position of the blade on the idle-side blade wheel.

The horizontal tilt of the blade wheel should be adjusted so that the blade tracks with the gullet of an 1-1/4" blade at 1/8" (3 mm) (3 mm) out from the front edge of the wheel ( $\pm 1/32$  [0.75 mm]).

7. Use the cant control adjustment to adjust the idle-side blade wheel.

If the blade is too far forward on the wheel, turn the cant control counterclockwise. If it is too far back on the wheel, turn the cant control clockwise.

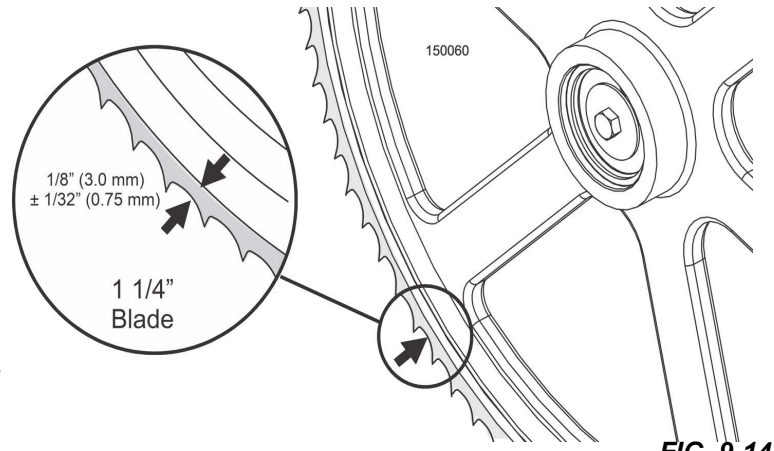

FIG. 9-14

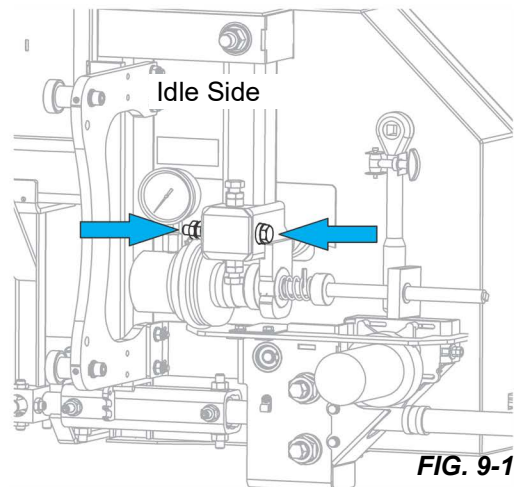
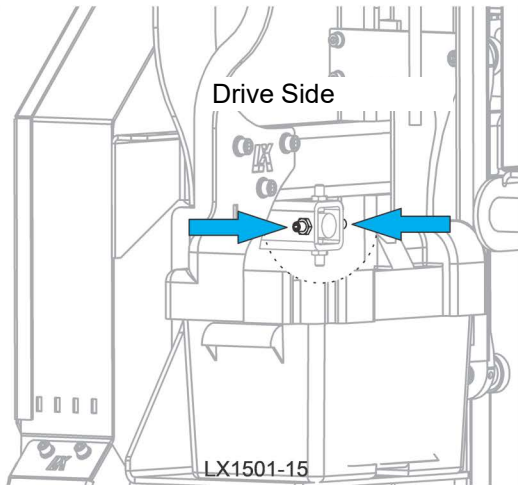

FIG. 9-15

8. If necessary, adjust the drive-side blade wheel to position the blade as shown in Figure 9-14.

**NOTE:** To move the blade back onto the blade drive wheel, loosen the right adjustment screw one quarter turn. Loosen the jam nut on the left adjustment screw and tighten the screw. Tighten the left and right jam nuts.

To move the blade out on the wheel, loosen the left adjustment screw one quarter turn. Loosen the jam nut on the right adjustment screw and tighten the screw. Tighten the left and right jam nuts.

### Blade Guide Re-installation

**NOTE:** Before re-installing the blade guide assemblies, remove the blade guide adjusting screws and apply a lubricating oil such as 10W30 or Dexron III to each screw. This will prevent the screws and threaded holes from corroding and make screw adjustments easier.

## 9 Sawmill Alignment

### Saw Head Tilt

1. Position outer blade guide assembly (with waterlube tube) to the mounting block on the blade guide arm so the that roller flange is **1/8" (3.0 MM)** from the blade.
2. Position the inner blade guide assembly to the mounting block on the saw head so that the roller flange is **1/16" (1.5 MM)** from the blade.
3. Tighten the two previously-loosened tilt adjustment screws to secure the blade guide assembly.
4. Loosen the top vertical adjustment jam nut and tighten the bottom vertical adjustment jam nut to adjust the blade guide roller up so it **DOES NOT TOUCH THE BLADE**.

### Saw Head Tilt

[See Section "Saw Head Tilt.](#)

### Blade Guide Arm Alignment

[See Section "Blade Guide Arm Alignment.](#)

### Blade Guide Deflection

Perform the following steps to achieve proper blade deflection with the blade guides.

1. Raise the saw head until the blade is 15" (375 mm) above a bed rail. Measure the actual distance with a tape from the top of the rail to the bottom of the blade.
2. Make sure the two vertical adjustment set screws are threaded into the blade guide shaft until they touch each other.

Loosen the bottom jam nut and tighten the top jam nut until the blade guide deflects the blade down until the bottom of the blade measures 14 3/4" (370 mm) from the bed rail.

3. Repeat for the other blade guide.

**NOTE:** Be sure that the blade guide deflector rod clears the blade on both guide assemblies. The rod on the outer guide assembly should be checked with the arm all the way in and all the way out.

### Blade Guide Vertical Tilt Alignment

[See Section "Blade Guide Vertical Tilt Alignment.](#)

### Blade Guide Horizontal Tilt Alignment

[See Section "Blade Guide Horizontal Tilt Adjustment.](#)

### Blade Guide Flange Spacing

[See Section "Blade Guide Flange Spacing.](#)

### Blade Height Scale Adjustment

[See Section "Blade Height Scale Adjustment.](#)

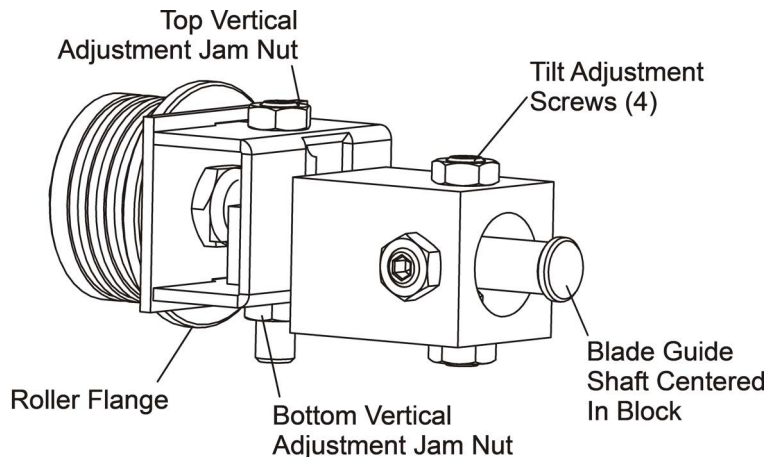

3H0802-15

**FIG. 9-16**

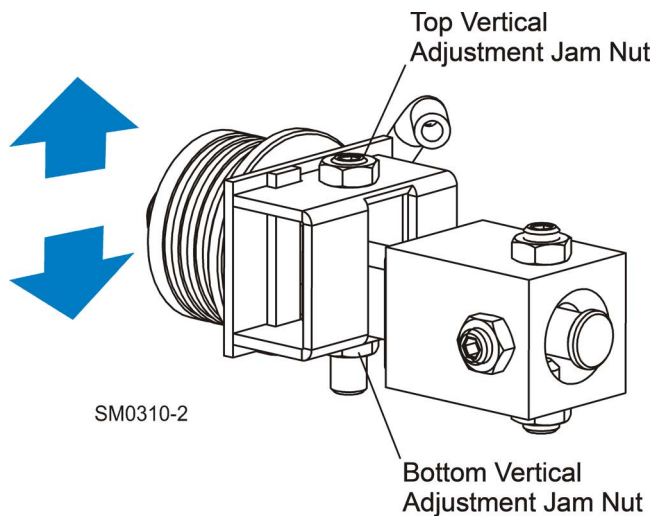

**FIG. 9-17**



# INDEX

---

## A

assembly  
bed sections 3-1

---

## B

blade  
breakage, troubleshooting 7-1

blade guide arm  
operation 5-8

---

## C

chain  
maintenance 6-6  
up/down tension 6-7

clutch/brake lever  
operation 5-3

---

## L

leveling logs 5-7

loading logs 5-6

---

## M

maintenance  
blade guide 6-1  
blade wheel belts 6-6  
carriage track/wipers 6-5  
drive belt 6-6  
mast rails 6-5  
miscellaneous 6-6  
part wear life 6-1  
sawdust removal 6-5  
up/down 6-7

---

---

## O

operation  
edging 5-10  
operation 8-1  
sawing 5-8  
troubleshooting 8-1  
diagnostic lights 8-1, 8-2  
error messages 8-1

---

## P

power feed  
operation 5-2  
speed adjustment 5-1, 5-2

---

## S

safety  
lockout procedure 2-3

Safety Instructions 2-1

Safety Symbols 1-1

scale  
blade height operation 5-10  
inch height 5-10  
quarter inch 5-11

simple set  
operation 5-3

---

## T

troubleshooting 7-1  
sawing problems 7-1

---

## U

up/down  
operation 5-8

---

---

**W**

water lube  
operation 5-12