

Models Effected:

PD200A10-CUW72
PD200A10-CUW84

PD200B10-CU
PD200B10-CU-HS
PD200B10-CUW72
PD200B10-CUW84

PD200C10-CU
PD200C10-CU-HS
PD200C10-CUW72
PD200C10-CUW72-HS
PD200C10-CUW84

**Pallet Dismantler
Safety, Operation,
Maintenance & Parts Manual**

Electric Center Drop Table Models rev.A2.01

Safety is our #1 concern!

Form #2316



WARNING! Read and understand this manual before using this machine.

California

Proposition 65 Warning



WARNING: Drilling, sawing, sanding or machining wood products can expose you to wood dust, a substance known to the State of California to cause cancer. Avoid inhaling wood dust or use a dust mask or other safeguards for personal protection.

For more information go to **www.P65Warnings.ca.gov/wood**.

Active Patents assigned to Wood-Mizer, LLC

Wood-Mizer, LLC has received patents that protect our inventions which are a result of a dedication to research, innovation, development, and design. Learn more at: woodmizer.com/patents

©2021 Wood-Mizer LLC

Printed in the United States of America, all rights reserved. No part of this manual may be reproduced in any form by any photographic, electronic, mechanical or other means or used in any information storage and retrieval system without written permission from

Wood-Mizer, LLC

8180 West 10th Street

Indianapolis, Indiana 46214

PD200 Pallet Dismantler

SECTION 1 INTRODUCTION

1.1	About this manual	1-1
1.2	Getting service	1-1
1.3	Specifications	1-4
1.4	Warranty.....	1-5

SECTION 2 GENERAL SAFETY

	<i>Owner's Responsibility</i>	<i>2-1</i>
2.1	Safety symbols	2-1
2.2	For models with engines	2-4
2.3	Electrical Lockout Procedures	2-6

SECTION 3 SETUP AND OPERATION

3.1	Site Preparation	3-1
3.2	Onsite setup.....	3-1
3.3	Operation.....	3-2
	<i>One-person operation</i>	<i>3-2</i>
	<i>Two-person operation</i>	<i>3-5</i>

SECTION 4 ELECTRICAL (1 PHASE)

4.1	Schematic	4-1
4.2	Device Tag/Parts List.....	4-3
4.3	Terminal line-up diagram.....	4-3
4.4	Cable Overview.....	4-4

SECTION 5 ELECTRICAL (3 PHASE)

5.1	Schematic	5-1
5.2	Device Tag/Parts List.....	5-3
5.3	Terminal line-up diagram	5-3
5.4	Cable Overview	5-4

SECTION 6 MAINTENANCE

6.1	General maintenance after each use.....	6-1
6.2	Tracking the blade.....	6-1
6.3	Changing the blade.....	6-2
6.4	Remove the drive hub	6-4

SECTION 7 PARTS

7.1 How To Use The Parts List7-1
 To Order Parts 7-1

7.2 Sample Assembly7-2

7.3 Pallet Dismantler Assembly7-3

7.4 Pallet Dismantler Parts (Drive Side)7-4

7.5 Motors.....7-6

7.6 Pallet Dismantler Parts (Idle Side)7-7

7.7 Pallet Dismantler Table Parts7-9

7.8 Table Control Assembly7-11

7.9 Motor Control Assembly7-12

7.10 Blade Guide Assembly7-14

7.11 Decals7-15

SECTION 1 Introduction

1.1 About this manual

Congratulations on your purchase of a Wood-Mizer Pallet Dismantler Conveyor!

When properly maintained and operated, your pallet dismantler conveyor should give you many years of dependable service.



CAUTION! Read this entire manual before operating the equipment. Take notice of all safety warnings throughout this manual and those posted on the equipment. Keep this manual with this equipment at all times, regardless of ownership.



Read all additional manufacturer's manuals and observe any applicable safety instructions including dangers, warnings, and cautions.

Only persons who have read and understood the entire operator's manual should operate the Wood-Mizer Pallet Dismantler Conveyor. The pallet dismantler conveyor is not intended for use by or around children.

1.2 Getting service

Wood-Mizer is committed to providing you with the latest technology, highest quality equipment, and strongest customer service available on the market today. We continually evaluate our customers' needs to ensure we're meeting current wood-processing demands. Your comments and suggestions are welcome.

GENERAL CONTACT INFORMATION

Toll free phone numbers are listed below for the *continental* U.S. and Canada. See the next page for contact information for more Wood-Mizer locations.

	United States	Canada
Sales	1-800-553-0182	1-877-866-0667
Service	1-800-525-8100	1-877-866-0667
Website	www.woodmizer.com	www.woodmizer.ca

E-mail	woodmizer@woodmizer.com	oninfo@woodmizer.com
---------------	-------------------------	----------------------

Office Hours: All times are Eastern Standard Time.

Monday - Friday	Saturday (Indianapolis Office Only)	Sunday
8 a.m. to 5 p.m.	8 a.m. to 12 p.m.	Closed

Please have your vehicle identification number and your customer number ready when you call.

Wood-Mizer will accept these methods of payment:

- Visa, Mastercard, or Discover
- COD
- Prepayment
- Net 15 (with approved credit)

Be aware that shipping and handling charges may apply. Handling charges are based on size and quantity of order. In most cases, items will ship on the day they are ordered. Second Day and Next Day shipping are available at additional cost.

If your pallet dismantler conveyor was purchased outside of the United States or Canada, contact the distributor for service.

WOOD-MIZER LOCATIONS

USA World Headquarters	Canadian Headquarters
<p><i>Serving North & South America, Oceania, East Asia</i></p> <p style="text-align: right;">Wood-Mizer LLC 8180 West 10th Street Indianapolis, IN 46214</p> <p>Phone: 317.271.1542 or 800.553.0182 Customer Service: 800.525.8100 Fax: 317.273.1011 Email: infocenter@woodmizer.com</p>	<p><i>Serving Canada</i></p> <p style="text-align: right;">Wood-Mizer Canada 396 County Road 36, Unit B Lindsay, ON K9V 4R3</p> <p>Phone: 705.878.5255 or 877.357.3373 Fax: 705.878.5355 Email: ContactCanada@woodmizer.com</p>

Brazilian Headquarters	European Headquarters
<p data-bbox="204 348 386 380">Serving Brazil</p> <p data-bbox="315 411 789 495">Wood-Mizer do Brasil Rua Dom Pedro 1, No: 205 Bairro: Sao Jose Ivoti/RS CEP:93.900-000</p> <p data-bbox="250 527 789 583">Tel: +55 51 9894-6461/ +55 21 8030-3338/ +55 51 3563-4784</p> <p data-bbox="285 585 651 617">Email: info@woodmizer.com.br</p>	<p data-bbox="850 348 1279 380">Serving Europe, Africa, West Asia</p> <p data-bbox="1078 411 1424 495">Wood-Mizer Industries Sp z o.o. Nagorna 114 62-600 Kolo, Poland</p> <p data-bbox="1149 527 1424 583">Phone: +48.63.26.26.000 Fax: +48.63.27.22.327</p>
Branches & Authorized Sales Centers	
For a complete list of dealers, visit www.woodmizer.com	

1.3 Specifications

Machine Dimensions:

Length: 10.5 ft (3.2 m), 11 ft, (3.35 m) 11.5 ft (3.50 m)
Width: 5 ft (1.5 m),
Height: 4 ft (1.2 m)
Weight: 1,800 lbs (820 k)

Material Handling:

Standard (S) 60" (1.52 m)
Wide (SW) 66" (1.68m)
72 (S72) 72" (1.83m)

Power:

19 HP gasoline engine
PD200A10 230v 1ph 10hp
PD200B10 230v 3ph 10hp
PD200C10 460v 3ph 10hp

Blade:

Top speed 2,200 fpm (670 m/min)
Material Bi-metal
Size: 1-1/4" x 0.042 thick
Life expectancy: 1,200 pallet or 3 days production
Teeth: 5-8 variable teeth per inch

Air Pressure:

Min: 80 psi (5.6 Kg/cm)
Max: 120 psi (8.4 Kg/cm)

Drive Wheels:

Hub size: 15"- 6 lugs x 5.5 bolt circle inch
Tire size: ST205/75D-15 bias ply only

1.4 Warranty

Wood-Mizer® LLC
Limited Product Warranty

Wood-Mizer®

Wood-Mizer LLC (“Warrantor”), an Indiana corporation with its principal place of business at 8180 West Tenth Street, Indianapolis, IN 46214-2400 USA, warrants to the purchaser (“Purchaser”) that for the time periods specifically stated herein and subject to the terms, conditions and limitations stated herein, the equipment manufactured by the Warrantor will be free from defects in material and workmanship attributable to Warrantor so long as, during the warranty periods stated herein, the equipment is installed, operated and maintained in accordance with the instructions provided by Warrantor.

PRODUCT	MODEL CLASS	LENGTH OF WARRANTY		EFFECTIVE DATE
		USA & CANADA	NON USA & CANADA	
Portable s, Resaws, Edgers	LT, HR, EG, LX	Two years	One year	Date of purchase
Portable s with Chassis	LT28, LT35, LT40, LT50, LT70, LX450	Two years, excluding the chassis; chassis shall have a five year warranty	One year	
Industrial s, Resaws, Edgers	WM, HR, EG, TVS, SVS, FS	One year	One year	Date of purchase or date of installation / training (if applicable), whichever occurs first, not to exceed 6 months from date of purchase
Material Handling	TWC, IC, TD, LD, GC, CR, CB, CC	One year	One year	
Pallet Dismantler	PD	One year	One year	Date of purchase
Blade Maintenance Equipment	BMS, BMT, BMST	One year	One year	
Options and Accessories	Various	One year*	One year ¹	
Moulders, Kilns	MP, SD	One year	One year	
Replacement Parts	Various	90 days	90 days	

¹ Warranty on Options will match the warranty on the primary equipment when purchased on same invoice.

EXCLUSIONS FROM 90 DAY, LIMITED ONE YEAR AND TWO YEAR WARRANTY

Warrantor shall have **no** responsibility under this warranty for any wear components, including, but not limited to: belts, blade guides, blades, electric motor brushes, drum switches, filters, fuses, hoses, bearings (excluding cylindrical drive bearings), bushings, cable carriers, and spark plugs. All wear components are furnished “**as is**”, without any warranty from Warrantor. This limited warranty does not cover any defects caused by

misuse, negligence, alterations, damage due to overload, abnormal conditions, excessive operation, accident, or lack of performance of normal maintenance services.

Several components which are used in the manufacture of the equipment but not manufactured by Warrantor, such as cant hooks, power plants, laser sights, batteries, tires, and trailer axles have warranties provided by the original equipment manufacturer (written copies available upon request). Warrantor does not separately warrant such items. Components or equipment manufactured by third parties are not covered by this warranty. Warrantor, however, will provide reasonable assistance to the Purchaser to make claims against any warranties applicable to such component parts as provided by such original equipment manufacturers. Components or equipment manufactured by third parties are not covered by this Warranty.

FIVE YEAR LIMITED CHASSIS WARRANTY

The limited five year chassis warranty, described above, DOES NOT extend to (a) any damage stemming from accident, improper towing, overload, abuse, misuse, abnormal conditions, negligence, excessive operation, or lack of maintenance, (b) rust caused by exposure to corrosive atmospheric conditions, or (c) the head, carriage, axle, brakes, or any hydraulic or electrical components attached to the chassis.

WARRANTOR'S OBLIGATIONS AS TO DEFECTS

In the event that the equipment fails to perform due to defective materials or workmanship attributable to Warrantor under normal use and service within the established warranty period, Purchaser's sole and exclusive remedy and Warrantor's sole liability shall be to replace or repair, in Warrantor's sole and subjective discretion, any defective part at Warrantor's principal place of business without cost to the Purchaser if such defect exists. The determination of whether a product is defective shall be made by Warrantor in Warrantor's sole and subjective discretion. The Purchaser must notify Warrantor prior to shipping any defective part. Warrantor, at its sole discretion, may cover expenses incurred in shipping the defective part to Warrantor for evaluation; provided, however, that Warrantor will not be responsible for labor, travel time, mileage, removal, installation, and/or incidental or consequential damages. However, any part in excess of 140 pounds must be returned by the Purchaser to the Warrantor's nearest authorized facility at the Purchaser's expense, if return is requested by Warrantor. Warrantor shall have a reasonable time within which to repair or replace the defective part. If Warrantor determines that the product is not defective under the terms of this warranty in Warrantor's sole and subjective discretion, then Purchaser shall be responsible for any expenses incurred by Warrantor in returning the equipment to the Purchaser.

LIMITATIONS AND DISCLAIMERS OF OTHER WARRANTIES

EXCEPT FOR THE EXPRESS WARRANTY PROVISIONS STATED ABOVE, WARRANTOR DISCLAIMS ALL WARRANTIES, EXPRESS AND/OR IMPLIED, INCLUDING AND WITHOUT LIMITATION, THE IMPLIED WARRANTIES OF MERCHANTABILITY, AND FITNESS FOR A PARTICULAR PURPOSE, NONINFRINGEMENT AND TITLE. No rep-

resentation or other affirmation of fact by representatives of Warrantor, whether verbal or in writing, including photographs, brochures, samples, models, or other sales aids, shall constitute a warranty, or any other basis, for any legal action against Warrantor. There are no other representations, promises, agreements, covenants, warranties, guarantees, stipulations or conditions, expressed or implied, by Warrantor, except as expressly set forth herein. THE ORIGINAL PURCHASER AND ANY INTENDED USER OR BENEFICIARY OF THIS EQUIPMENT, SHALL NOT BE ENTITLED TO RECOVER ANY INDIRECT, SPECIAL, PUNITIVE, EXEMPLARY, CONSEQUENTIAL, SPECIAL, OR INCIDENTAL DAMAGES OR LOSSES, INCLUDING BUT NOT LIMITED TO, DAMAGES OF LOST PRODUCTION, LOST REVENUE, LOST PRODUCT, LOST PROFITS, LOST BUSINESS, LOSS OF USE, LOSS OF GOODWILL, OR BUSINESS INTERRUPTION, FROM WARRANTOR FOR ANY REASON WHATSOEVER INCLUDING, WITHOUT LIMITATION, WARRANTY OR DEFECT IN THE PRODUCT REGARDLESS OF THE SOLE, JOINT, AND/OR CONCURRENT NEGLIGENCE, BREACH OF CONTRACT, BREACH OF WARRANTY, STRICT LIABILITY IN TORT OR STATUTORY CLAIMS, OR OTHER LEGAL FAULT, OR RESPONSIBILITY OF EITHER WARRANTOR OR PURCHASER OR ITS EMPLOYEES OR AGENTS. Warrantor does not warrant that its equipment meets or complies with the requirements of any particular safety code or governmental requirements.

Defective items, replaced under the terms of this warranty, become the property of Warrantor.

DESIGN CHANGES

Warrantor reserves the right to change the design of its products from time to time without notice and without obligation to make corresponding changes in or to its products previously manufactured.

RIGHTS OF PURCHASERS

The validity and effect of this limited warranty, as well as its interpretation, operation and effect, shall be determined exclusively by the principles of law and equity of the State of Indiana, USA. This limited warranty gives Purchaser specific legal rights. Purchaser may also have other rights, which may vary from state to state. Some states may not allow limitations as to the duration of implied warranties or to the exclusion or limitation of incidental or consequential damages, therefore some of the limitations and exclusions detailed set forth above may not apply. In the event that any one or more of the provisions of this warranty shall be or become invalid, illegal or unenforceable in any respect, the validity, legality and enforceability of the remaining provisions of this warranty shall not be affected thereby.

INTERPRETATIONS

This Warranty constitutes the entire warranty agreement between Warrantor and Purchaser and supersedes any prior understandings or agreements pertaining to the same subject matter. This

1 *Warranty*

warranty cannot be amended, except in writing, which refers to this warranty that is signed by both Warrantor and Purchaser.

Effective: January 1, 2018

© 2013 Wood-Mizer LLC – 8180 West 10th Street, Indianapolis, IN 46214

SECTION 2 General Safety

Owner's Responsibility



IMPORTANT! It is always the **owner's responsibility** to comply with all applicable safety instructions, as well as federal, state and local laws, rules and regulations regarding the ownership and operation equipment. All owners should be thoroughly familiar with all applicable safety instructions and laws and comply with them fully while using or transporting the equipment.



WARNING! Clean sawdust from all guards, vents, control boxes, or any area where sawdust may gather **after every shift**. Failure to do so may result in fire.



NOTE: ONLY safety instructions regarding **personal injury** are listed in this section. Safety instructions regarding only equipment damage appear where applicable throughout the manual.

2.1 Safety symbols

The following symbols and signal words call your attention to instructions concerning your personal safety. Be sure to observe and follow these instructions.



DANGER! indicates an imminently hazardous situation which, if not avoided, will result in death or serious injury.



WARNING! suggests a potentially hazardous situation which, if not avoided, could result in death or serious injury.



CAUTION! refers to potentially hazardous situations which, if not avoided, may result in minor or moderate injury or damage to equipment.



IMPORTANT! indicates vital information.

NOTE: gives helpful information.

OBSERVE SAFETY INSTRUCTIONS**IMPORTANT!**

- Keep children away from the area.
- Read the entire operator's manual before operating the equipment.
- Take notice of all safety warnings throughout this manual and those posted on the machine.
- Keep this manual with this machine at all times, regardless of ownership.
- Read all additional manufacturer's manuals.
- Obey all applicable safety instructions including dangers, warnings, and cautions.
- Only persons who have read and understood the entire operator's manual should operate the equipment.

**WEAR SAFETY CLOTHING**

WARNING! Secure all loose clothing and jewelry before operating the equipment. Failure to do so may result in death or serious injury.



WARNING! Always wear hand, eye, ear, and foot protection when operating or servicing the equipment. Failure to do so may result in death or serious injury.

**EQUIPMENT SETUP**

DANGER! Do not operate the equipment without all covers and guards in place. Failure to do so may result in death or serious injury.





WARNING! Set up the equipment on solid, level ground. Failure to do so may result in death or serious injury.



WARNING! Check that the tire pressures are between 50-55 psi. Failure to do so may result in death or serious injury.

KEEP HANDS AWAY

 **DANGER!** Keep hands 12" away from the blade. Failure to do so will result in death or serious injury.

 **DANGER!** Remove power before clearing debris or any other maintenance activity. Failure to do so will result in death or serious injury.

 **WARNING!** Avoid contact with any hot parts (engines or motors). Failure to do so may result in death or serious injury.

Allow the system to cool sufficiently before beginning any service function, including debris removal.

 **WARNING!** Avoid contact with sharp edges of the cutting blade. Failure to do so may result in death or serious injury.



KEEP EQUIPMENT AND AREA AROUND EQUIPMENT CLEAN

 **DANGER!** Maintain a clean and clear path for all necessary movement around the equipment and stacking areas. Failure to do so will result in death or serious injury.

 **WARNING!** Do not allow children in the area of the equipment. Failure to do so may result in death or serious injury.

DISPOSE OF WOOD BY-PRODUCTS PROPERLY

 **IMPORTANT!** Properly dispose of all wood by-products, including sawdust, chips, and other debris, including operation waste such as coolant, oil, fuel, oil filters, fuel filters, etc.





KEEP SAFETY LABELS IN GOOD CONDITION

 **IMPORTANT!** Ensure that all safety decals are clean and readable. Replace all damaged safety decals to prevent personal injury or damage to the equipment. Contact your local distributor, or call your Customer Service Representative to order more decals.

 **IMPORTANT!** If replacing a component that has a safety decal affixed to it, ensure the new component also has the safety decal affixed.



2.2 For models with engines

HANDLE FUEL/LUBRICANTS SAFELY



-  **DANGER!** Keep all fuel and lubricants away from children. Failure to do so will result in death or serious injury.
-  **DANGER!** Never smoke, weld, grind or allow sparks near your engine or storage tanks. Failure to do so will result in death or serious injury.
-  **DANGER!** Never spill fuel on a hot engine. Failure to do so will result in death or serious injury.
-  **WARNING!** Store gasoline away from flammable materials. Failure to do so may result in death or serious injury.
-  **WARNING!** Never use flammable fuels or liquids to clean the wedge. Failure to do so can damage the equipment and may result in death or serious injury.









CAUTIONS FOR GAS ENGINE OPERATION

-  **DANGER!** Operate your engine/machine only in well ventilated areas. Failure to do so will result in death or serious injury.
-  **DANGER!** Never operate your engine/machine indoors or within a confined space. Failure to do so will result in death or serious injury.
-  **DANGER!** Never operate an engine with a fuel or oil leak, which can result in fire. Failure to do so will result in death or serious injury.

USE CAUTION WHEN WORKING WITH BATTERIES

-  **DANGER!** Keep sparks, flames, burning cigarettes, or other ignition sources away from batteries at all times. Failure to do so will cause death or serious injury.
-  **DANGER!** Always wear safety goggles and a face shield when working near batteries. Failure to do so will cause serious injury.

- 
WARNING! Battery posts, terminals, and related accessories contain lead and lead compounds. Wash hands after handling. Failure to do so may cause death or serious injury.
- 
WARNING! Charge the battery in a well ventilated area. Failure to do so may result death or serious injury.
- 
WARNING! Disconnect the negative battery terminal cable before performing any service to the 12-Volt electrical system. Failure to do so may result in injury and/or electrical system damage.
- 
WARNING! Do not attempt to charge a frozen battery. Failure to do so may result death or serious injury.
- 
CAUTION! Do not overcharge the battery. Overcharging may reduce the overall service life of the battery.
- 
CAUTION! Be sure the battery is fully charged before transporting the pallet dismantler. If the battery is not fully charged, excessive vibration could reduce the overall service life of the battery.

EMERGENCY TREATMENT FOR CONTACT WITH BATTERY COMPONENTS (LEAD/SULFURIC ACID) per SDS (Safety Data Sheet):

EYE CONTACT	Sulfuric Acid and Lead: Flush eyes immediately with large amounts of water for at least 15 minutes while lifting lids. Seek immediate medical attention if eyes have been exposed directly to acid.
SKIN CONTACT	Sulfuric Acid: Flush affected area(s) with large amounts of water using deluge emergency shower, if available, shower for at least 15 minutes. Remove contaminated clothing, including shoes. If symptoms persist, seek medical attention. Wash contaminated clothing before reuse. Discard contaminated shoes. Lead: Wash immediately with soap and water.
INGESTION	Sulfuric Acid: Administer large amounts of water. Do NOT induce vomiting or aspiration into the lungs may occur and can cause permanent injury or death; consult physician.
INHALATION	Sulfuric Acid: Remove to fresh air immediately. If not breathing, give artificial respiration. If breathing is difficult, give oxygen. Consult a physician. Lead: Remove from exposure, gargle, wash nose and lips; consult physician.

2.3 Electrical Lockout Procedures

RULES FOR USING LOCKOUT PROCEDURE

The equipment shall be locked out to protect against accidental or inadvertent operation when such operation could cause injury to personnel. Do not attempt to operate any switch or valve bearing a lock. Lockout procedures must be used during:

Table 1:

Changing or adjusting blades	Electrical maintenance
Unjamming operations	Retrieval of tools/parts from work area
Cleaning	Activities where guards or electrical panel guard is open or removed
Mechanical repair	

Maintenance hazards include:

Table 2:

Blade contact	Missiles (thrown blades/wood chips)
Pinch points	Electrical
Kickbacks	

Failure to lockout may result in:

Table 3:

Cut	Serious injury and death
Crush	Amputation
Blindness	Burn
Puncture	Shock
Electrocution	

To control maintenance dangers:

- Lockout procedures must be followed (see OSHA regulation 1910.147).
- Never rely on machine stop control for maintenance safety (emergency stops, on/off buttons, interlocks).

- Do not reach into moving blades or feed systems. Allow all coasting parts to come to a complete stop.
- Electrical power supply and air supply must both be locked out.
- Where established lockout procedures cannot be used (electrical troubleshooting or mechanical dynamic troubleshooting), alternative effective protective techniques shall be employed which may require special skills and planning.
- Always follow safe operations practices in the workplace.

S LOCKOUT PROCEDURE

Lockout procedures per OSHA regulation 1910.147, appendix A:

GENERAL

The following simple lockout procedure is provided to assist owner/operators in developing their procedures so they meet the requirements of OSHA regulation 1910.147. When the energy isolating devices are not lockable, tagout may be used, provided the owner/operator complies with the provisions of the standard which require additional training and more rigorous periodic inspections. When tagout is used and the energy isolating devices are lockable, the owner/operator must provide full operator protection (see OSHA regulation 1910.147, paragraph (c)(3)) and additional training and more rigorous periodic inspections are required. For more complex systems, more comprehensive procedures may need to be developed, documented, and utilized.

PURPOSE

This procedure establishes the minimum requirements for the lockout of energy isolating devices whenever maintenance or servicing is done on machines or equipment. It shall be used to ensure that the machine or equipment is stopped, isolated from all potentially hazardous energy sources and locked out before personnel perform any servicing or maintenance where the unexpected energization or start-up of the machine or equipment or release of stored energy could cause injury.

COMPLIANCE WITH THIS PROGRAM

All personnel are required to comply with the restrictions and limitations imposed upon them during the use of lockout. The authorized personnel are required to perform the lockout in accordance with this procedure. All operators, upon observing a machine or piece of equipment which is locked out to perform servicing or maintenance shall not attempt to start, energize, or use that machine or equipment.

SEQUENCE OF LOCKOUT

1. Notify all affected personnel that servicing or maintenance is required on a machine or equipment and that the machine or equipment must be shut down and locked out to perform the servicing or maintenance.
2. The authorized employee shall refer to the company procedure to identify the type and magnitude of the energy that the machine or equipment utilizes, shall understand the hazards of the energy, and shall know the methods to control the energy.
3. If the machine or equipment is operating, shut it down by the normal stopping procedure (depress the stop button, open switch, close valve, etc.).
4. De-activate the energy isolating device(s) so that the machine or equipment is isolated from the energy source(s).
5. Lock out the energy isolating device(s) with assigned individual lock(s).
6. Stored or residual energy (such as that in capacitors, springs, elevated machine members, rotating flywheels, hydraulic systems, and air, gas, steam, or water pressure, etc.) must be dissipated or restrained by methods such as grounding, repositioning, blocking, bleeding down, etc.
7. Ensure that the equipment is disconnected from the energy source(s) by first checking that no personnel are exposed, then verify the isolation of the equipment by operating the push button or other normal operating control(s) or by testing to make certain the equipment will not operate.



CAUTION! Return operating control(s) to neutral or "off" position after verifying the isolation of the equipment.

8. The machine or equipment is now locked out.

RESTORING EQUIPMENT TO SERVICE

When the servicing or maintenance is completed and the machine or equipment is ready to return to normal operating condition, the following steps shall be taken.

1. Check the machine or equipment and the immediate area around the machine to ensure that nonessential items have been removed and that the machine or equipment components are operationally intact.
2. Check the work area to ensure that all personnel have been safely positioned or removed from the area.
3. Verify that the controls are in neutral.

4. Remove the lockout devices and reenergize the machine or equipment.

NOTE: The removal of some forms of blocking may require re-energization of the machine before safe removal.

5. Notify affected personnel that the servicing or maintenance is completed and the machine or equipment is ready for use.

PROCEDURE INVOLVING MORE THAN ONE PERSON

In the preceding steps, if more than one individual is required to lock out the equipment, **each shall place his own personal lock on the energy isolating devices.**

SECTION 3 SETUP AND OPERATION

3.1 Site Preparation

An outside source of compressed air adjustable from 80-120 psi (5.6-8.4 Kg/cm) is required.



WARNING! Have a certified electrician install the power to your machine. Failure to do so may result in death or serious injury.



WARNING! Be sure the power supply cables are not a trip hazard. Failure to do so may result in death or serious injury.



CAUTION! Improper voltage will cause damage to the motor and electronic components. Have a qualified electrician install the power supply to begin using your pallet dismantler.



IMPORTANT! The power supply must meet the motor specifications concerning wire size, fused disconnect, and voltage, which are provided in the motor's manual. The electrical installation must also meet local codes.



IMPORTANT! Ensure the blade spins in the proper direction. If not, have the electrician change the engine rotation.

3.2 Onsite setup



DANGER! Maintain a clean and clear path for all necessary movement around the pallet dismantler and stacking areas. Failure to do so will result in death or serious injury.



WARNING! Do not allow children in the area of the pallet dismantler. Failure to do so may result in death or serious injury.



WARNING! Do not set up the pallet dismantler on ground with more than a 10 degree incline. Failure to do so may result in death or serious injury.

FOR GAS ENGINES





DANGER! Do not operate this unit indoors or in an enclosed area; carbon monoxide poisoning will occur. Failure to do so will result in death or serious injury.

3.3 Operation

 **DANGER!** Keep hands 12" away from the blade. Failure to do so will result in death or serious injury.

 **WARNING!** Do not load pallets greater than 60" (1.5 m). Failure to do so may result in death or serious injury.

 **WARNING!** Avoid contact with sharp edges of the cutting wedges. Failure to do so may result in death or serious injury.

 **WARNING!** Check that the tire pressures are between 50-55 psi. Failure to do so may result in death or serious injury.



FOR GAS ENGINES

 **DANGER!** Do not operate this unit indoors or in an enclosed area; carbon monoxide poisoning will occur. Failure to do so will result in death or serious injury.

One-person operation

 **IMPORTANT!** Before starting, ensure the blade is tensioned properly. Failure to do so may result in drive wheel tire damage.

6. Tighten the tension by ratcheting the device handle until the pivot arm is touching the stop bolt.

NOTE: If a new blade is required see Section [6.3 Changing the blade](#).

See Figure 3-1.

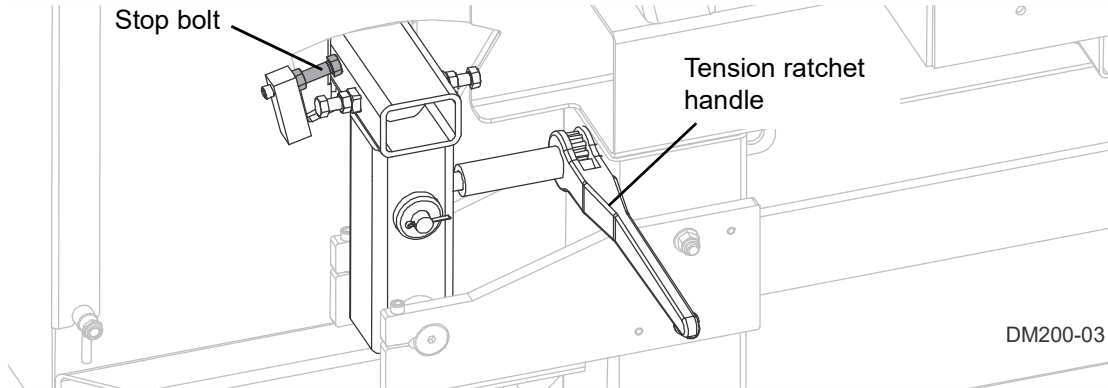

FIG. 3-1

7. Remove the pass back bars from the table top by unpinning them and slide them out.
8. Momentarily (approximately 15 seconds) run the blade on the drive wheels.
9. Turn off disconnect.
10. Open the wheel covers to inspect the blade tracking.

NOTE: If the blade is not tracking in the center of the tire, refer to [Section 6.2 Tracking the blade.](#)

11. When the blade is tracking properly, close the wheel covers and turn on the disconnect.
12. Start the blade.

See Figure 3-2.

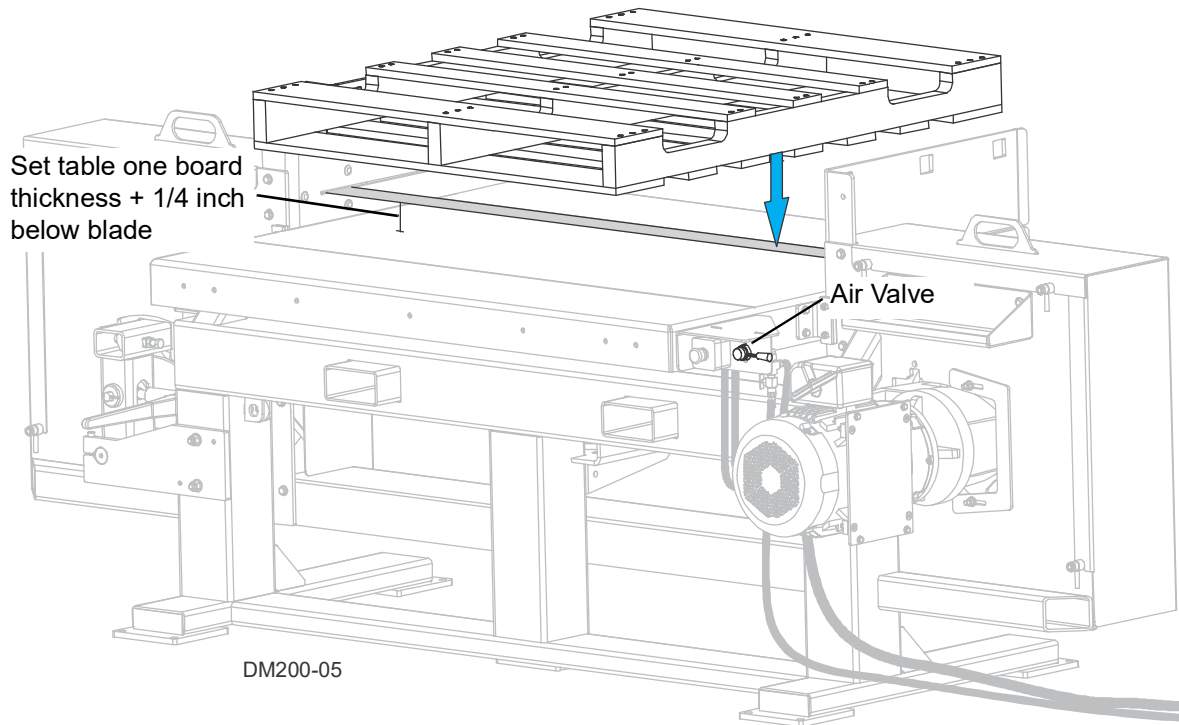

FIG. 3-2

13. Use the air valve to adjust the table approximately one board thickness plus 1/4 inch (6 mm) below the blade.

Air valve controls: Neutral is the 3 o'clock position. Raise the handle up to raise the table; lower handle to lower table. Always return the handle to the neutral position.

14. Place half the pallet over the blade and lower the pallet so the blade is positioned between two deck boards. (See figure 3-2.)

15. Pull the pallet away from the blade.

NOTE: Move the pallet from side-to-side as you pull to ease the cut.

16. Lift and rotate the pallet to remove the other half of the boards.

17. Turn the pallet over and repeat Step 14. through Step 16.

18. Remove the last board by pulling the stringers from left to right.

Two-person operation



IMPORTANT! Before starting, ensure the blade is tensioned properly. Failure to do so may result in drive wheel tire damage.

1. Tighten the tension by ratcheting the device handle until the pivot arm is touching the stop bolt.

See Figure 3-3.

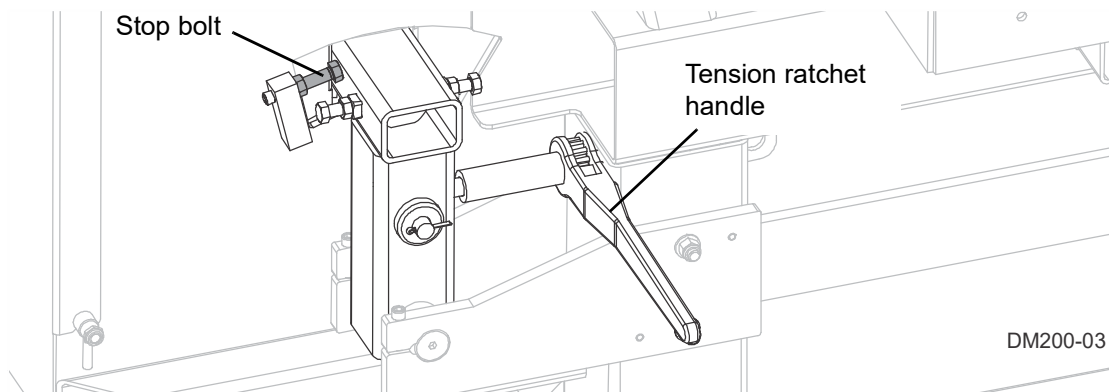

FIG. 3-3

NOTE: If a new blade is required see Section [6.3 Changing the blade](#).

2. Momentarily (approximately 15 seconds) start the blade.
3. Turn off power.
4. Open the wheel covers to inspect the blade tracking.

NOTE: If the blade is not tracking in the center of the tire, refer to [Section 6.2 Tracking the blade](#).

5. When the blade is tracking properly, close the wheel covers and turn on the power.

See Figure 3-4.

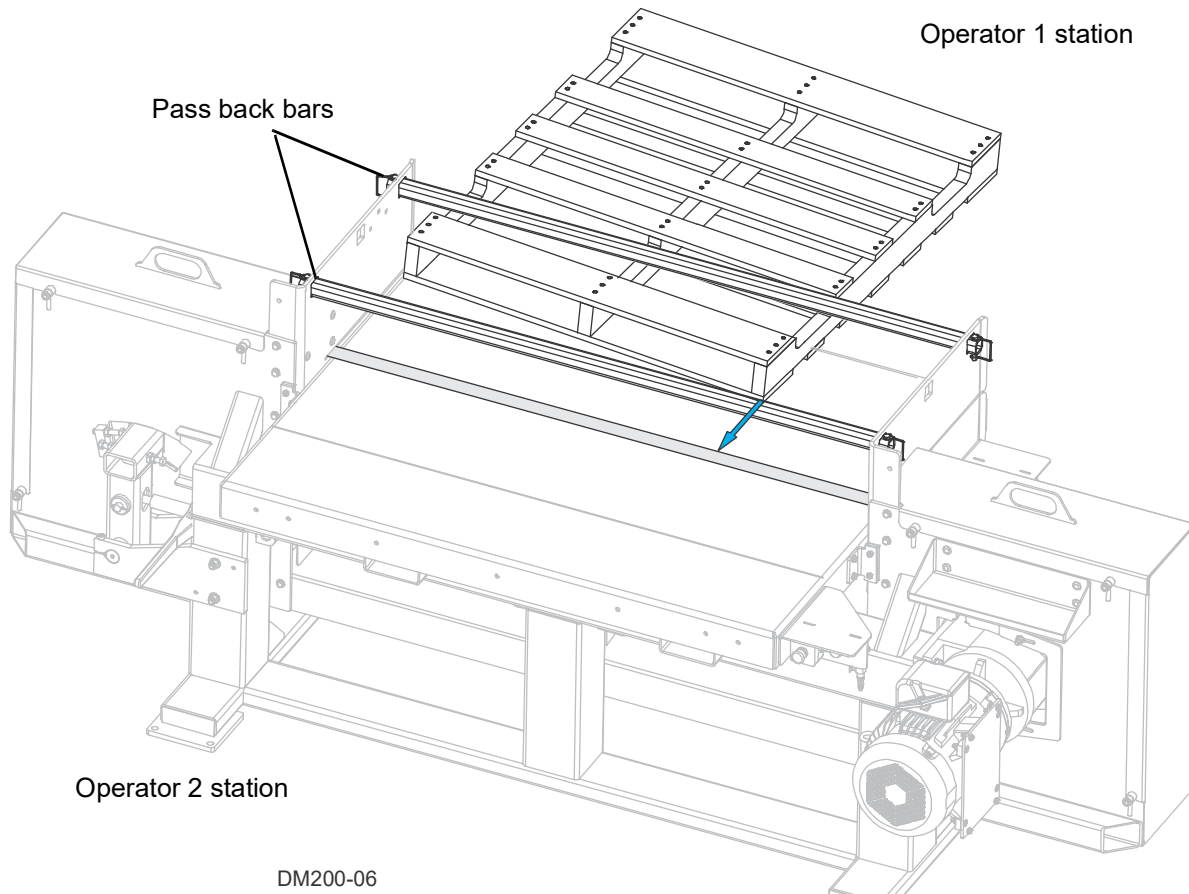

FIG. 3-4

6. Use the air valve to adjust the table approximately one board thickness plus 1/4 inch (6 mm) below the blade.

Air valve controls: Neutral is the 3 o'clock position. Raise the handle up to raise the table; lower handle to lower table. Always return the handle to the neutral position.

7. **Operator 1:** Place the pallet on the table with the deck side down and against the fence.
8. **Operator 1:** Start the blade.



IMPORTANT! Only one person should have contact with the pallet while cutting.

9. **Operator 1:** With the pallet at a slight angle to the blade, push the pallet half way through the blade.(See Figure 3-4.)



DANGER! Keep hands 12” away from the blade. Failure to do so will result in death or serious injury.

NOTE: Move the pallet from side-to-side as you push or pull to ease the cut.

10. **Operator 2:** Pull the pallet completely through the blade.
11. **Operator 2:** Turn the pallet over and place it on the pass back bars.
12. **Operator 1:** Place the pallet on the table and against the fence.
13. **Operator 1:** With the pallet at a slight angle to the blade, push the pallet half way through the blade.
14. **Operator 2:** Pull the pallet completely through the blade.
15. **Either operator:** Turn off blade.



DANGER! Remove power before clearing debris or any other maintenance activity. Failure to do so will result in death or serious injury.

16. **Operator 2:** Clear lumber and debris from the table to make it ready for the next pallet.
17. Repeat Step 7. through Step 16.

4.2 Device Tag/Parts List

Device tag	Function	Wood-Mizer Part Number	Wood-Mizer Description	Qty.	X-Ref (Schematic)
K1	Contactora	061344	Contactora, 43A 3P 120VAC Coil IEC	1	118
M1	Blade Motor	079949	Motor, 10hp Dismantler, 1ph	1	102
OL1	Overload Protection	061345	Overload, 9-45A Class 10-15-20-30 NO/NC	1	102
S1	Start	073791	Pushbutton, Black Momentary 30mm Flush	1	118
S2	Stop	073792	Switch, E-Stop Maintd Push/Pull 30mm Red	1	118
S3	Front E-Stop	052999	E-Stop Box, 40mm Oper-10A NC	1	118
S4	Back E-Stop	052999	E-Stop Box, 40mm Oper-10A NC	1	118
T1	Control Transformer	073797	TFMR, 50VA 208/240/277/480/575V ->120V	1	112

4.3 Terminal line-up diagram

Terminal strip +L1-X1								
Terminal				Jumper		End Plate	Remark	Terminal X-Ref (Schematic)
Ref. Des.	Level	P/N	Description	Diagram	P/N	P/N		
TB1		073790	Terminal Block, 2Pos Cage Clamp					110
TB2		073790	Terminal Block, 2Pos Cage Clamp					110
TB3		073790	Terminal Block, 2Pos Cage Clamp					109
TB4		073790	Terminal Block, 2Pos Cage Clamp					109
TB5		073790	Terminal Block, 2Pos Cage Clamp					105
TB6		073790	Terminal Block, 2Pos Cage Clamp					105
TB7		073790	Terminal Block, 2Pos Cage Clamp					114
TB8		073790	Terminal Block, 2Pos Cage Clamp					118

Terminal				Jumper		End Plate	Remark	Terminal X-Ref (Schematic)
Ref. Des.	Level	P/N	Description	Diagram	P/N	P/N		
X4		052293-2	Junction Block, 2-Position Wire Clamp					118

4.4 Cable Overview

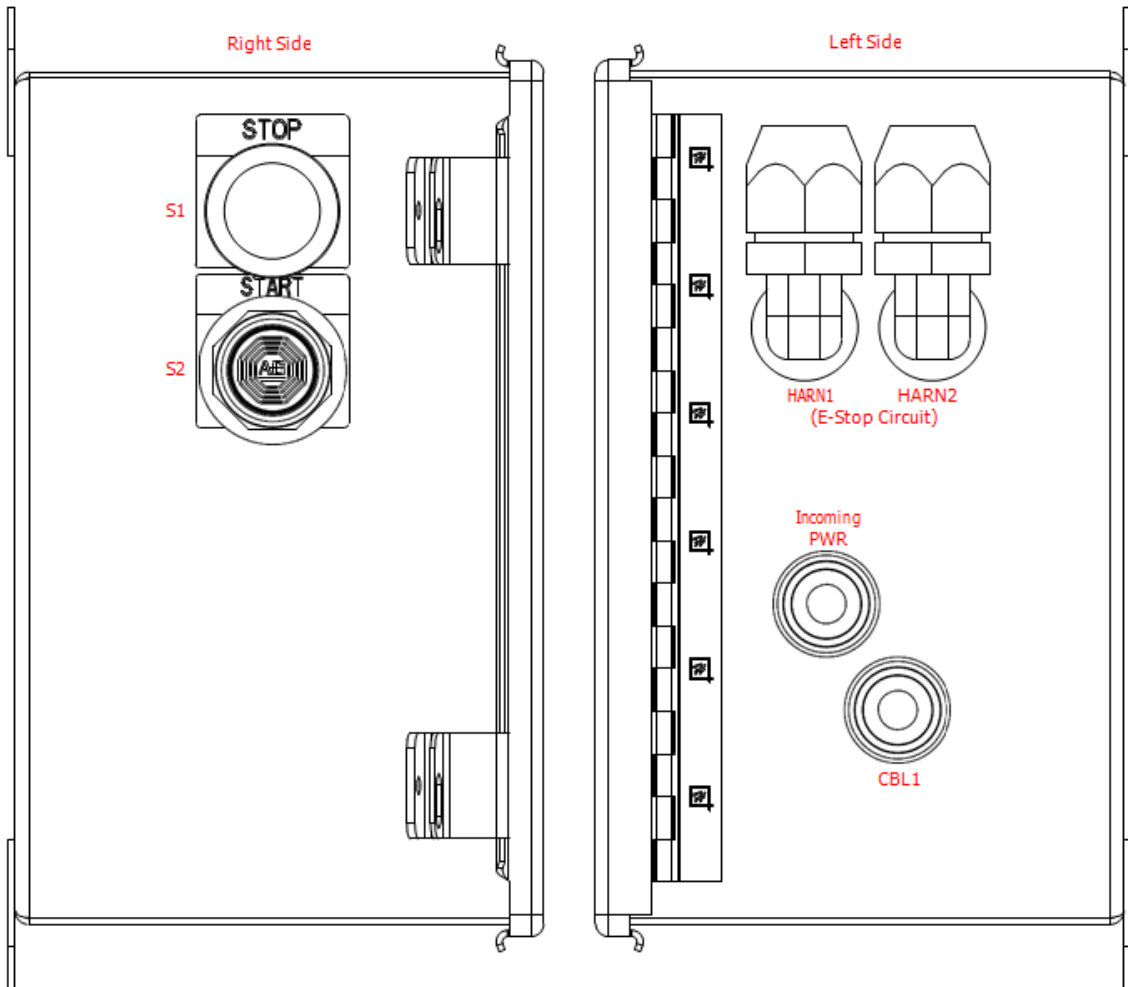

Cable Designation	Cable Part Number	Cable Description	Cable X-Ref (Schematic)
CBL1	073800	Cable Assy, 230V 1Ph Pallet Hawg Motor	102
HARN1	073803	Harness Assy, Pallet Hawg Back E-Stop	118
HARN2	073805	Harness Assy, Pallet Hawg Front E-Stop	118

SECTION 5 ELECTRICAL (3 PHASE)

5.1 Schematic

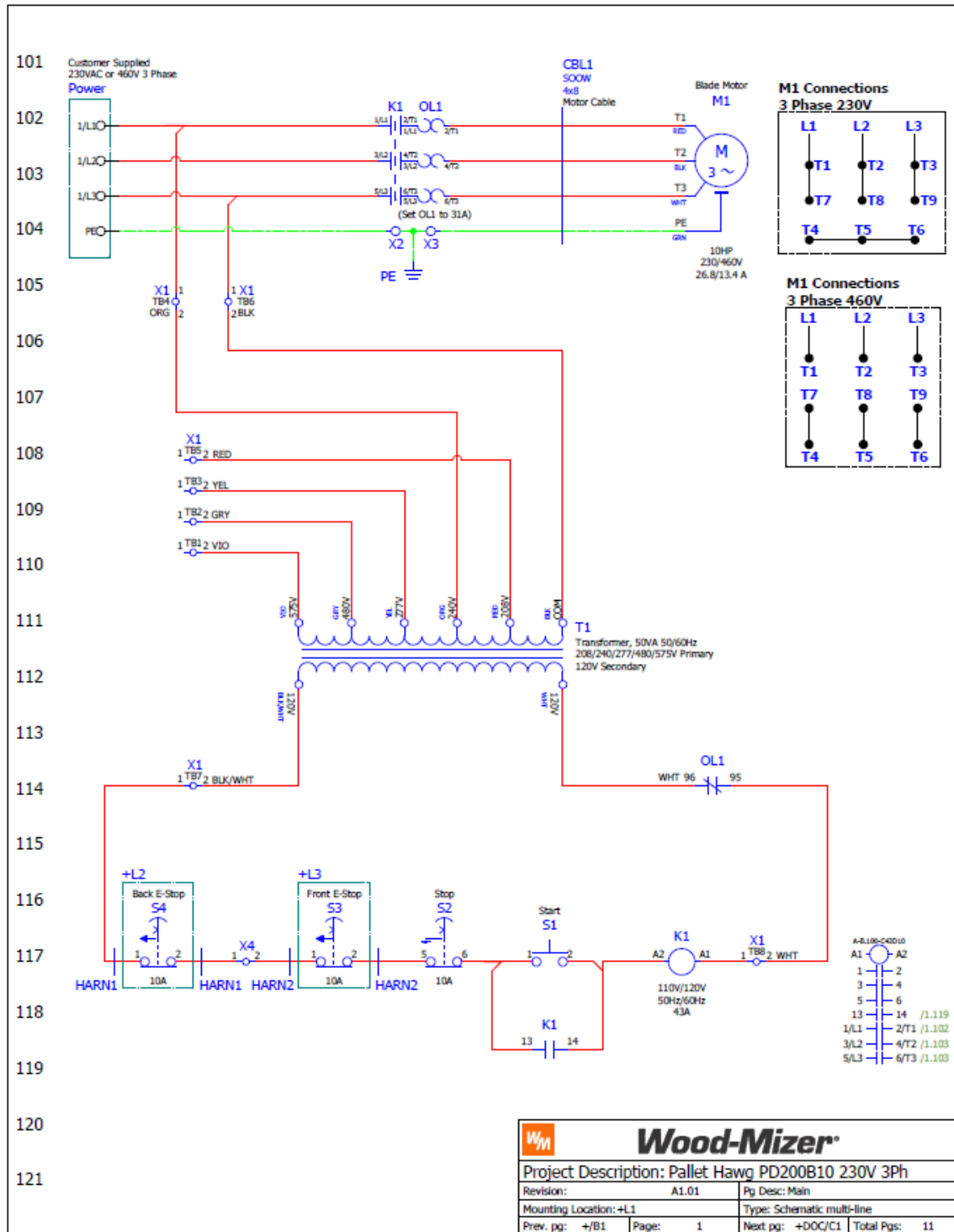

See Figure 5-1.

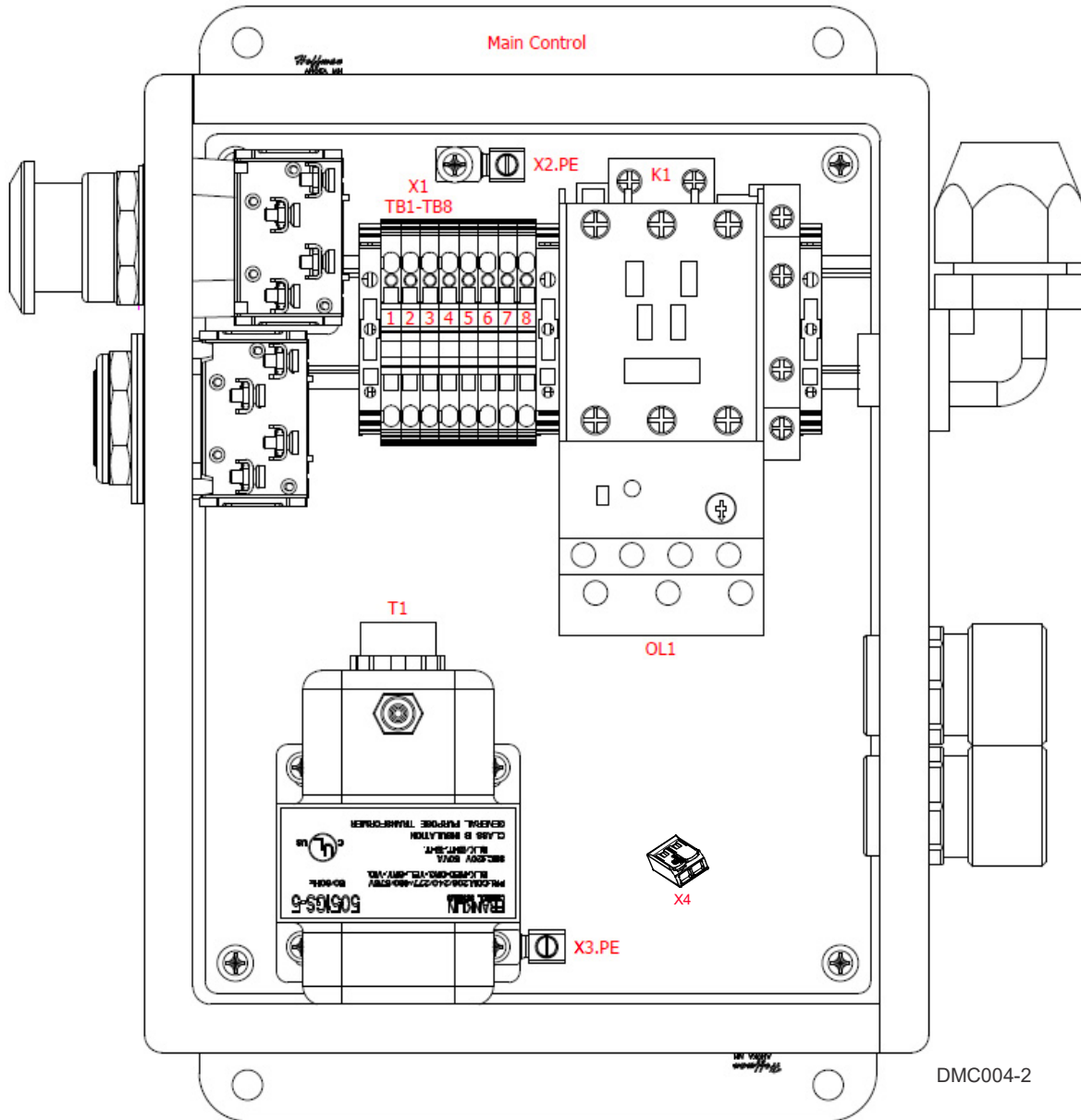

5.2 Device Tag/Parts List

Device tag	Function	Wood-Mizer	Wood-Mizer Description	Qty.	X-Ref
K1	Contactor	073786	Contactor, 43A 3P 120VAC Coil IEC	1	118
M1	Blade Motor	079937	Motor, 10hp Dismantler, 3ph	1	102
OL1	Overload Protection	073789	Overload, 9-45A Class 10-15-20-30 NO/NC	1	102
S1	Start	073791	Pushbutton, Black Momentary 30mm Flush	1	118
S2	Stop	073792	Switch, E-Stop Maintd Push/Pull 30mm Red	1	118
S3	Front E-Stop	052999	E-Stop Box, 40mm Oper-10A NC	1	118
S4	Back E-Stop	052999	E-Stop Box, 40mm Oper-10A NC	1	118
T1	Control Transformer	073797	TFMR, 50VA 208/240/277/480/575V ->120V	1	112

5.3 Terminal line-up diagram

Terminal strip +L1-X1							
Terminal			Jumper		End Plate	Remark	Terminal X-Ref (Schematic)
Ref. Des.	Level	P/N	Description	Dia-	P/N		
TB1		073790	Terminal Block, 2Pos Cage Clamp				110
TB2		073790	Terminal Block, 2Pos Cage Clamp				110
TB3		073790	Terminal Block, 2Pos Cage Clamp				109
TB4		073790	Terminal Block, 2Pos Cage Clamp				109
TB5		073790	Terminal Block, 2Pos Cage Clamp				105
TB6		073790	Terminal Block, 2Pos Cage Clamp				105
TB7		073790	Terminal Block, 2Pos Cage Clamp				114
TB8		073790	Terminal Block, 2Pos Cage Clamp				118

Terminal strip							
Terminal			Jumper		End Plate	Remark	Terminal X-Ref (Schematic)
Ref. Des.	Level	P/N	Description	Diagram	P/N		
X2		073798	Ground Lug, Single Position				104

Terminal strip							
Terminal			Jumper		End Plate	Remark	Terminal X-Ref (Schematic)
Ref. Des.	Level	P/N	Description	Diagram	P/N		
X3		073798	Ground Lug, Single Position				104

Terminal strip							
Terminal			Jumper		End Plate	Remark	Terminal X-Ref (Schematic)
Ref. Des.	Level	P/N	Description	Diagram	P/N		
X4		052293-2	Junction Block, 2-Position Wire				118

5.4 Cable Overview

Cable Designation	Cable Part Number	Cable Description	Cable X-Ref (Schematic)
CBL1	073800	Cable Assy, 230V 1Ph Pallet Hawg Motor	102
HARN1	073803	Harness Assy, Pallet Hawg Back E-Stop	118
HARN2	073805	Harness Assy, Pallet Hawg Front E-Stop	118

See Figure 5-2.

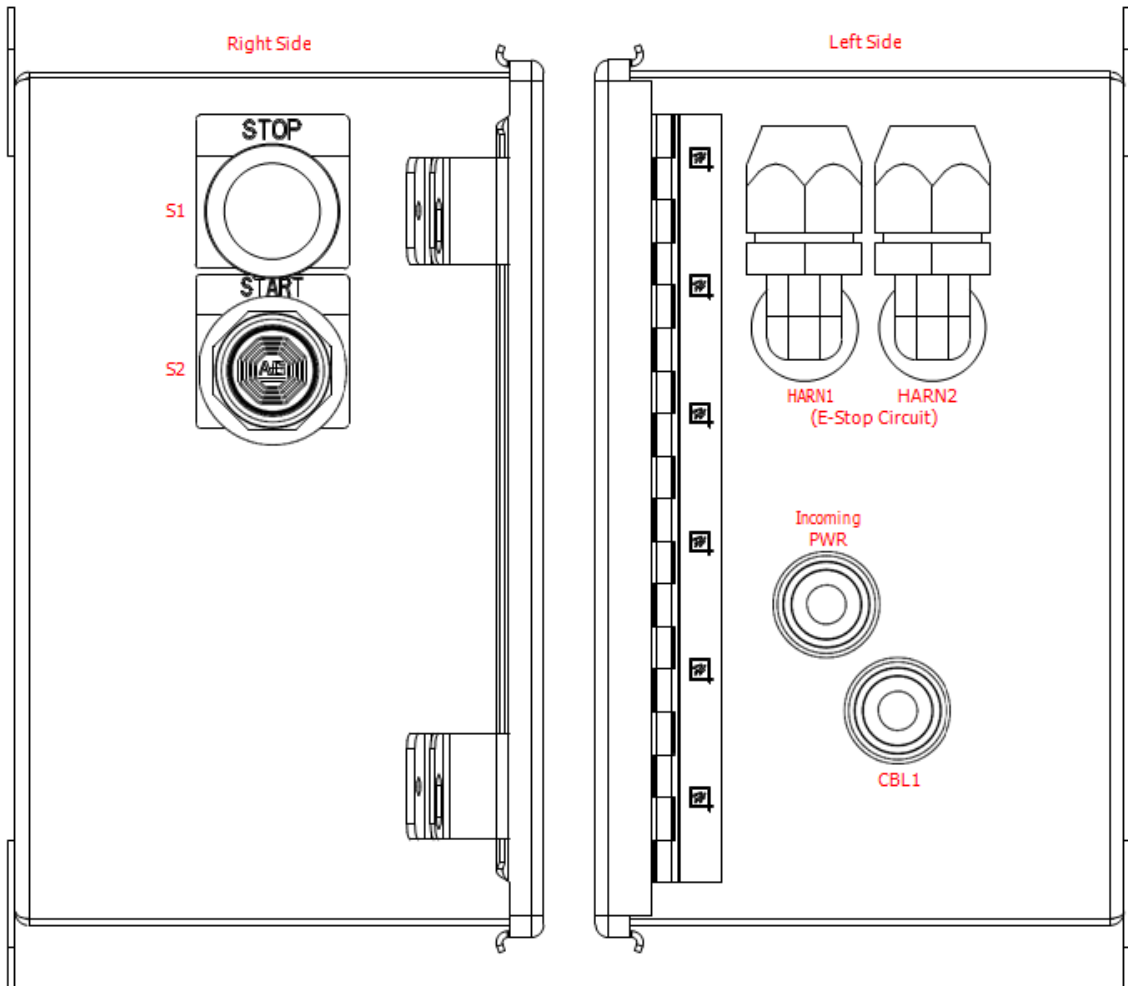

SECTION 6 MAINTENANCE



WARNING! Before performing service, lock out the electrical service as described in section 2.4. Failure to do so could result in death or serious injury.

Refer to Online Manuals for electrical schematics.

6.1 General maintenance after each use

1. Check for debris impeding any moving parts.
2. Clean debris off of the motor or engine and fuel tank.
3. Check engine oil per motor/engine manufacturer's manual specifications.
4. Check that the tire pressure are between 50-55 psi.
5. Check gearbox oil level per gearbox manufacturer's manual specifications.



IMPORTANT! DO NOT OVERFILL THE GEARBOX. The gearbox is mounted in the B7 wall mounting position. In this mounting position the unit requires **6.1 PINTS** of oil.

Recommend lubricants are:

Mobile (Mobilgear 630)
Castrol (Alpha SP220)
Texaco (Meropa 220)

Citgo (EP Compound 220)
Shell (Omala 220)
Chevron (Gear Compound EP ISO2200)

6.2 Tracking the blade



WARNING! Before performing service, lock out the electrical service as described in section 2.4. Failure to do so could result in death or serious injury.

1. Open the wheel covers to observe the blade on the drive wheels.
2. Loosen the lock nuts on the tensioner.

See Figure 6-1.

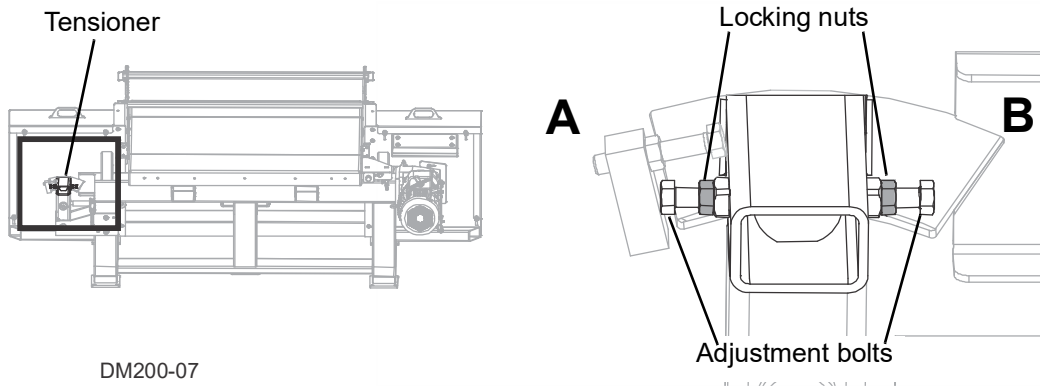

FIG. 6-1

3. Loosen the inner (**B**) while tightening the outer (**A**) bolt to move the blade **TOWARD THE BLADE GUIDE BEARING**.
4. Loosen the outer (**A**) while tightening the inner (**B**) bolt to move the blade **AWAY FROM THE BLADE GUIDE BEARING**.



IMPORTANT! Do not move the adjustment bolts more than 1/4 turn per adjustment. This adjustment is sensitive.

5. Close the wheel covers.
6. Momentarily (approximately 15 seconds) start the blade.
7. Ensure power is off before performing the next steps.
8. Open the wheel covers to observe the blade on the drive wheels.
9. Repeat Step 3. through Step 8. as necessary for the blade to track properly.
10. Tighten the lock nuts when finished.

6.3 Changing the blade



WARNING! Before performing service, lock out the electrical service as described in section 2.4. Failure to do so could result in death or serious injury.

1. Open the wheel covers to observe the blade on the drive wheels.

2. Release the tension by ratcheting the device until the pivot arm is fully released.

See Figure 6-2.

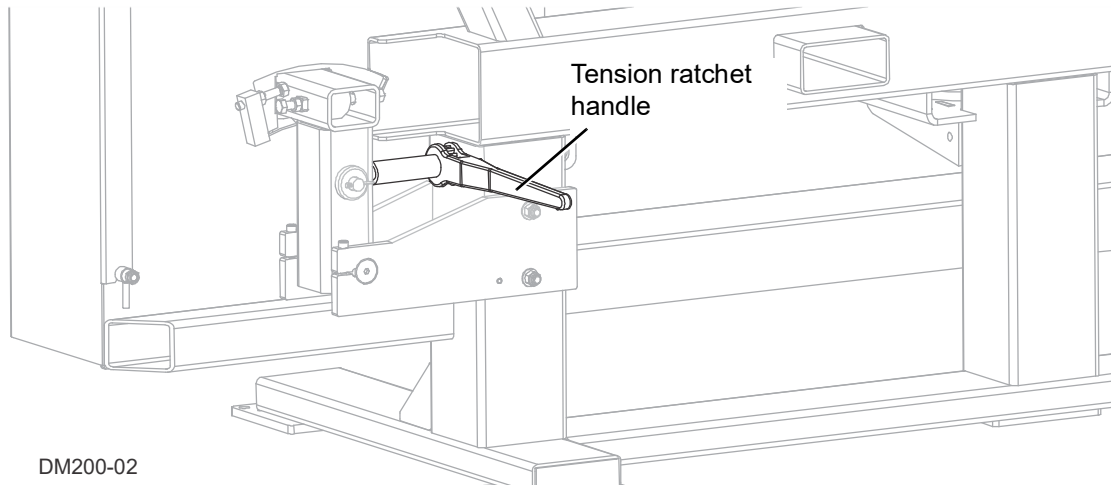

FIG. 6-2

3. Removed the used blade.
4. Install the new blade on the center of the drive wheel tires.



IMPORTANT! Ensure the blade is positioned as shown below in Figure 6-3.

See Figure 6-3.

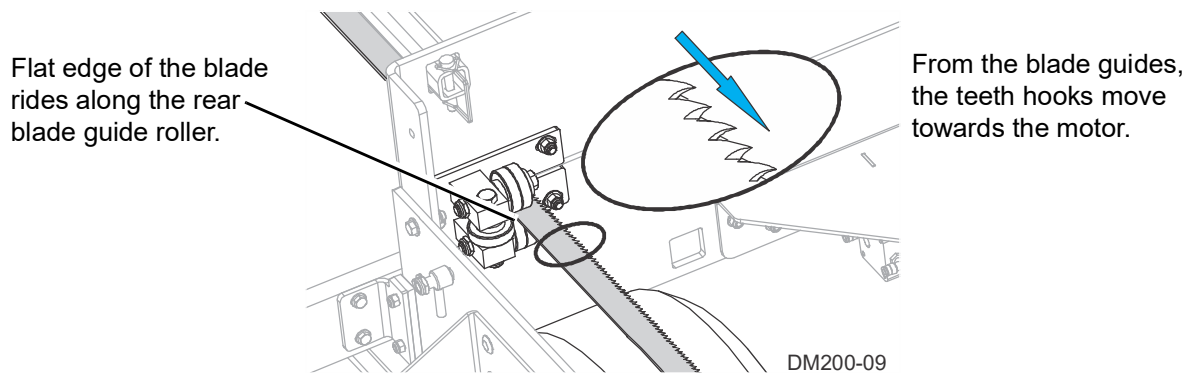

FIG. 6-3

5. Tighten the tension by ratcheting the device handle until the pivot arm is touching the stop bolt.

See Figure 6-4.

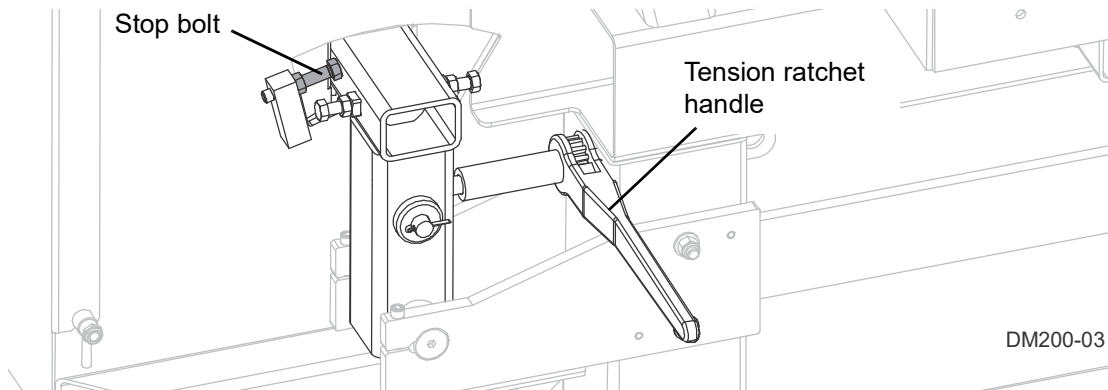

FIG. 6-4

6. Close the wheel covers.
7. Momentarily (approximately 15 seconds) start the blade.
8. Ensure power is off before performing the next steps.
9. Open the wheel covers to observe the blade on the drive wheels.

NOTE: If the blade is not tracking in the center of the tire, refer to [Section 6.2 Tracking the blade](#).

10. When the blade is tracking properly, close the wheel covers and continue operations.

6.4 Remove the drive hub

Occasionally bearings will need to be changed on the gearbox.

1. Remove the blade drive wheel cover.
2. Loosen and remove the blade. Refer to [Section 6.3 Changing the blade](#).
3. Remove the drive wheel by loosening and removing the six lug nuts.

See Figure 6-5.

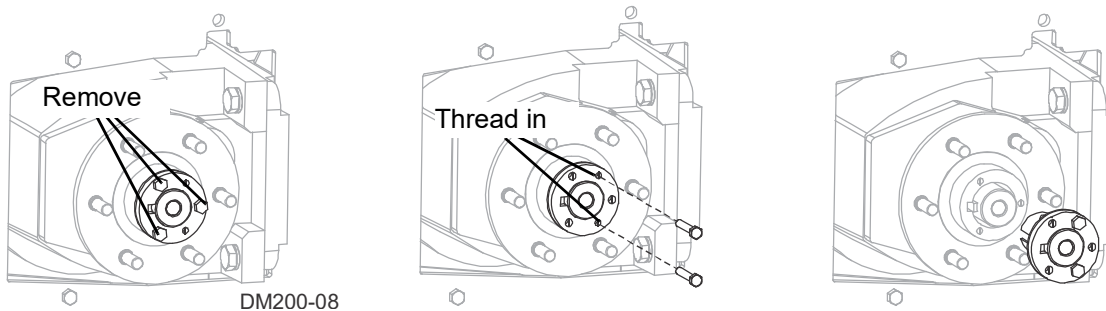

FIG. 6-5

4. Remove the three bolts in the tapered bushing on the drive shaft.
5. Replace two of the bolts into the treaded holes.
6. Alternate tighten the two bolts until the bushing releases from the wheel flange.

The gearbox is now accessible for maintenance.

SECTION 7 PARTS

7.1 How To Use The Parts List

- Use the table of contents to locate the assembly that contains the part you need.
- Go to the appropriate section and locate the part in the illustration.
- Use the number pointing to the part to locate the correct part number and description in the table.
- Parts shown indented under another part are included with that part.

To Order Parts

- From the continental US, call **1-800-525-8100** to order parts. Have your customer number, vehicle identification number, and part numbers ready when you call.
- From other international locations, contact the Wood-Mizer distributor in your area for parts.

7.2 Sample Assembly

REF	DESCRIPTION (♦ Indicates Parts Available in Assemblies Only)	PART #	QTY.
	SAMPLE ASSEMBLY, COMPLETE (INCLUDES ALL INDENTED PARTS BELOW)	012345	1
1	Sample Part	F02222-22	1
2	Sample Part	F03333-33	2
	Sample Subassembly (Includes All Indented Parts Below)	098765	1
3	Subassembly Sample Part	S04444-44	1
4	Subassembly Sample Part	K55555	1
	Sample Sub-Subassembly (Includes All Indented Parts Below)	054321	2
5	Sub-Subassembly Sample Part	022222	1
6	Sub-Subassembly Sample Part	F10234-56	1

The Sample Assembly, Complete, part number 02345 (top level assembly) includes two parts (F0222-22 and F0333-33) and the 098765 subassembly.

Subassembly 098765 contains two parts(S04444-44 and K55555) and two copies of sub-subassembly 054321.

Each sub-subassembly 054321 contains two parts (022222 and F10234-56).

7.3 Pallet Dismantler Assembly

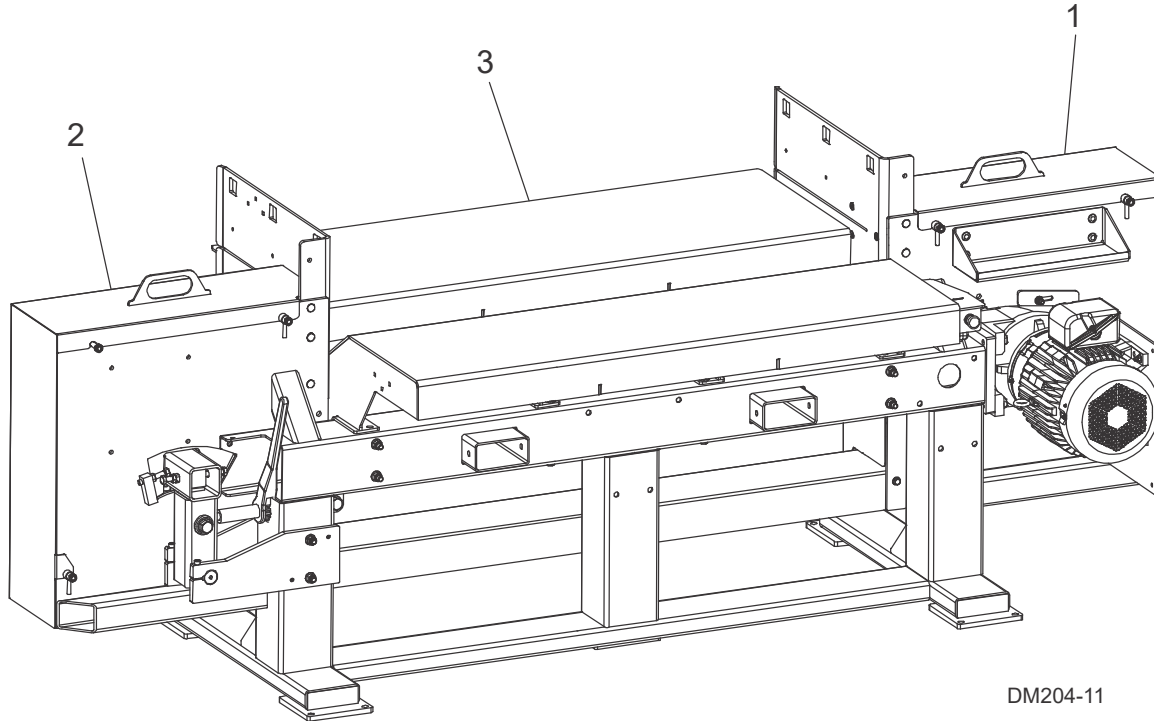

DM204-11

REF	DESCRIPTION (♦ Indicates Parts Available in Assemblies Only)	PART #	QTY.
	Dismantler ASSEMBLY, Pallet	PD200	1
1	Pallet Dismantler Parts (Drive Side) (See Section 7.4)		
2	Pallet Dismantler Parts (Idle Side) (See Section 7.6)		
3	Pallet Dismantler Table Parts (See Section 7.7)		

7 Parts

Pallet Dismantler Parts (Drive Side)

7.4 Pallet Dismantler Parts (Drive Side)

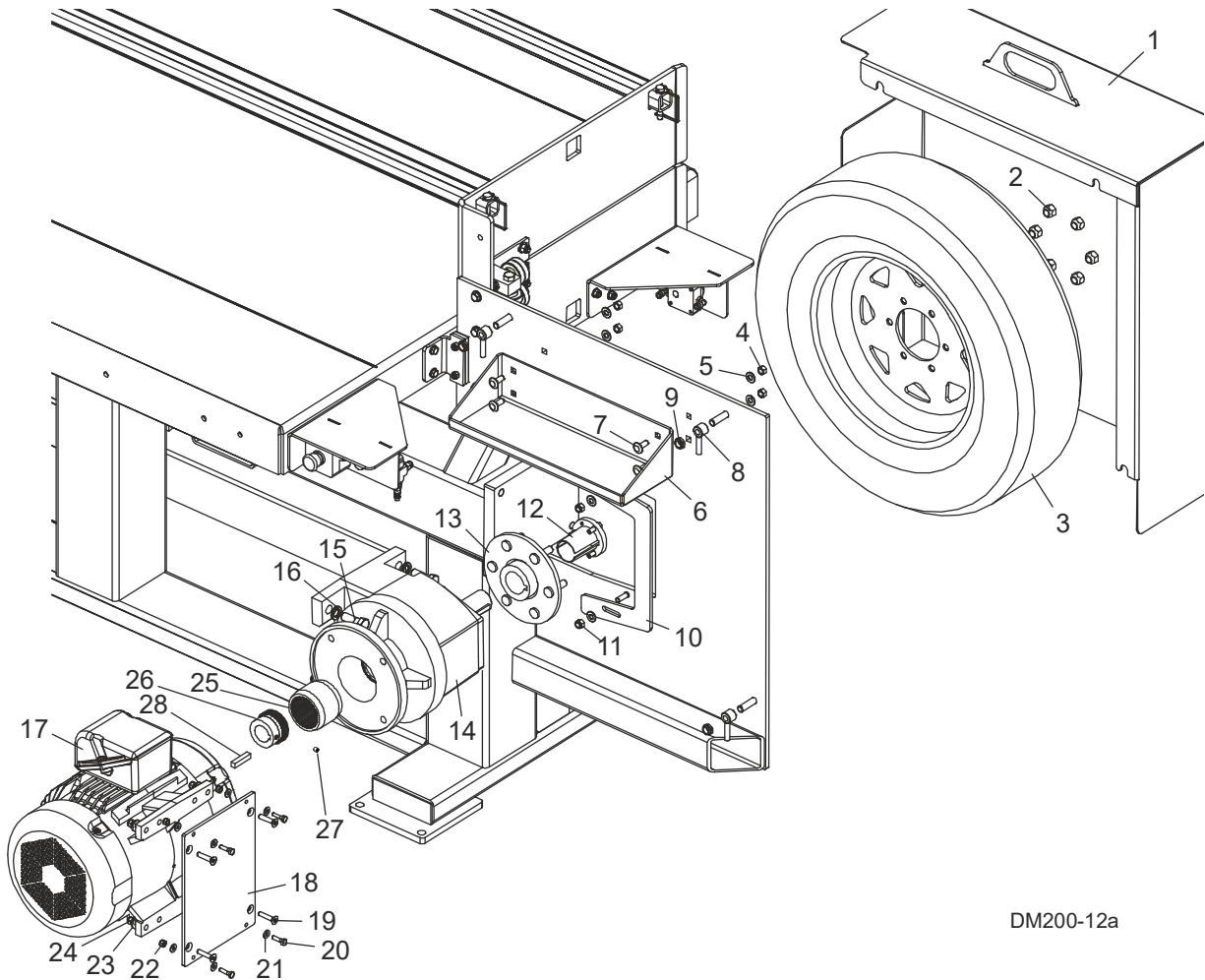

DM200-12a

REF	DESCRIPTION (♦ Indicates Parts Available in Assemblies Only)	PART #	QTY.
1	Cover Weldment, Dismantler, Drive	079980	1
2	Nut, 1/2-20 Lug	P04646	6
3	Tire/Wheel Assembly, ST205/75D15	079939	1
4	Nut, 3/8-16 Swaged Lock	F05010-25	4
5	Washer, 3/8 Flat SAE	F05011-3	6
6	Tray, Dismantler Tool	079982	1
7	Bolt, 3/8-16x1 Carriage, Zinc Grade 5	F05007-165	4
8	Nut Weldment, Cover	021145	3
9	Nut, 1/2-13 Half Nyloc	F05010-127	3
10	Plate, Adapter	079981	2
11	Nut, 3/8-16 Hex Nyloc	F05010-10	2
12	Bushing, P2x1 5/8	079945	1
13	Hub Assembly, Dismantler Dr	079984	1

REF	DESCRIPTION (♦ Indicates Parts Available in Assemblies Only)	PART #	QTY.
14	Reducer, 6:1 Inline	079936 ¹	1
15	Bolt, 5/8-11x1 3/4 Hex Head	F05009-33	4
16	Washer, 5/8 Split Lock	F05011-27	4
17	Motor (See 7.5 Motors)		
18	Mount, PD200E Control	114116	1
19	Bolt, 5/16-18x1 1/2 FH FT BO	F05008-86	4
20	Bolt, 1/4-20x1 Hex Head Grade 5	F05005-101	4
21	Washer, 1/4 SAE Flat	F05011-11	8
22	Nut, 1/4-20 Nylock	F05010-69	4
23	Washer, 5/16 Standard Flat	F05011-16	4
24	Nut, 5/16-18 Nylok Hex	F05010-58	4
	Coupler Assy, M38x1 3/8 BoWex	130150	1
25	Sleeve, Bowex Coupler	130185	1
	Hub, Bowex Coupler, 1 3/8	130184	1
26	Part, New	130183_1	1
27	Screw, M8-1.25x8mm SH Set BO	F05004-234	1
28	Key, 3/8x3/8x1 7/8	014693	4

¹ Parts to rebuild this reducer are available through Motion Industries. The model number is 772.1. The recommended gear oil is Mobile 630. Fill qty is 2.6 quarts. Oil is available in quart size through Grainger.

7.5 Motors

Motor Part Number	Used with models	
079949 Motor, 10hp 1 PH Dismantler	PD200A10-SU	PALLET DISM,230V1PH10HP,STD TBL.,UL
	PD200A10-SUW	PALLET DISM,230V1PH10HP,STD TBL.,UL, 66"
	PD200A10-SUW72	PALLET DISM. 220V 1 PH. 10HP,STD.TBL. UL
	PD200A10-SUW84	PALLET DISM,220V1PH10HP,STD TBL.,UL, 84"
008737 Motor, 10HP 3525RPM, Lincoln	PD200B10-CU-HS	PALLET DISM, 230V 3PH10HP, CTR TBL, UL,
	PD200B10-RU-HS	PALLET DISM, 230V3PH10HP,REAR DRP, UL
	PD200C10-CUW72-HS	PALLET DISM, 460V3PH10HP,CTR TBL.,UL, HS
	PD200C10-RU-HS	PALLET DISM, 460V3PH10HP,REAR DRP, UL
	PD200B10-SU-HS	PALLET DISM,230V3PH10HP,STD TBL.,UL, HS
	PD200C10-CU-HS	PALLET DISM,460V3PH10HP,CTR TBL.,UL
	PD200C10-SU-HS	PALLET DISM,460V3PH10HP,STD TBL.,UL
	PD200C10-SUW-HS	PALLET DISM,460V3PH10HP,STD UL, 66", HS
079937 Motor, 10hp Dismantler 3ph	PD200B10-RUW72	PALLET DISM, 230V 3 PH 10 HP, REAR DRP
	PD200B10-CU	PALLET DISM, 230V 3PH10HP, CTR TBL, UL
	PD200B10-CUW72	PALLET DISM, 230V 3PH10HP, CTR TBL, UL
	PD200B10-RU	PALLET DISM, 230V3PH10HP,REAR DRP, UL
	PD200C10-RUW72	PALLET DISM, 460V 3 PH 10 HP, REAR DRP
	PD200C10-RU	PALLET DISM, 460V3PH10HP,REAR DRP, UL
	PD200B10-BU	PALLET DISM,230V3PH10HP,CTR TBL.,UL*OBS*
	PD200B10-SU	PALLET DISM,230V3PH10HP,STD TBL.,UL
	PD200B10-SUW	PALLET DISM,230V3PH10HP,STD TBL.,UL, 66"
	PD200B10-SUW72	PALLET DISM,230V3PH10HP,STD TBL.,UL, 72"
	PD200B10-SUW84	PALLET DISM,230V3PH10HP,STD TBL.,UL, 84"
	PD200B10-SUW96	PALLET DISM,230V3PH10HP,STD TBL.,UL, 96"
	PD200H10-SS	PALLET DISM,400V3PH50HZ,10HP,STD TBL
	PD200C10-CU	PALLET DISM,460V3PH10HP,CTR TBL.,UL
	PD200C10-SU	PALLET DISM,460V3PH10HP,STD TBL.,UL
	PD200C10-SUW	PALLET DISM,460V3PH10HP,STD TBL.,UL, 66"
	PD200C10-SUW72	PALLET DISM,460V3PH10HP,STD TBL.,UL, 72"
	PD200C10-SUW84	PALLET DISM,460V3PH10HP,STD TBL.,UL, 84"
	110401 Motor, 10hp 575v, 1750rpm	PD200K10-CU
PD200K10-RU		PALLET DISM, 575V3PH10HP,REAR DRP, UL
PD200K10-SU		PALLET DISM, 575V3PH10HP,STD TBL.,UL
PD200K10-SUW72		PALLET DISM,575V3PH10HP,STD TBL.,UL, 72"

7.6 Pallet Dismantler Parts (Idle Side)

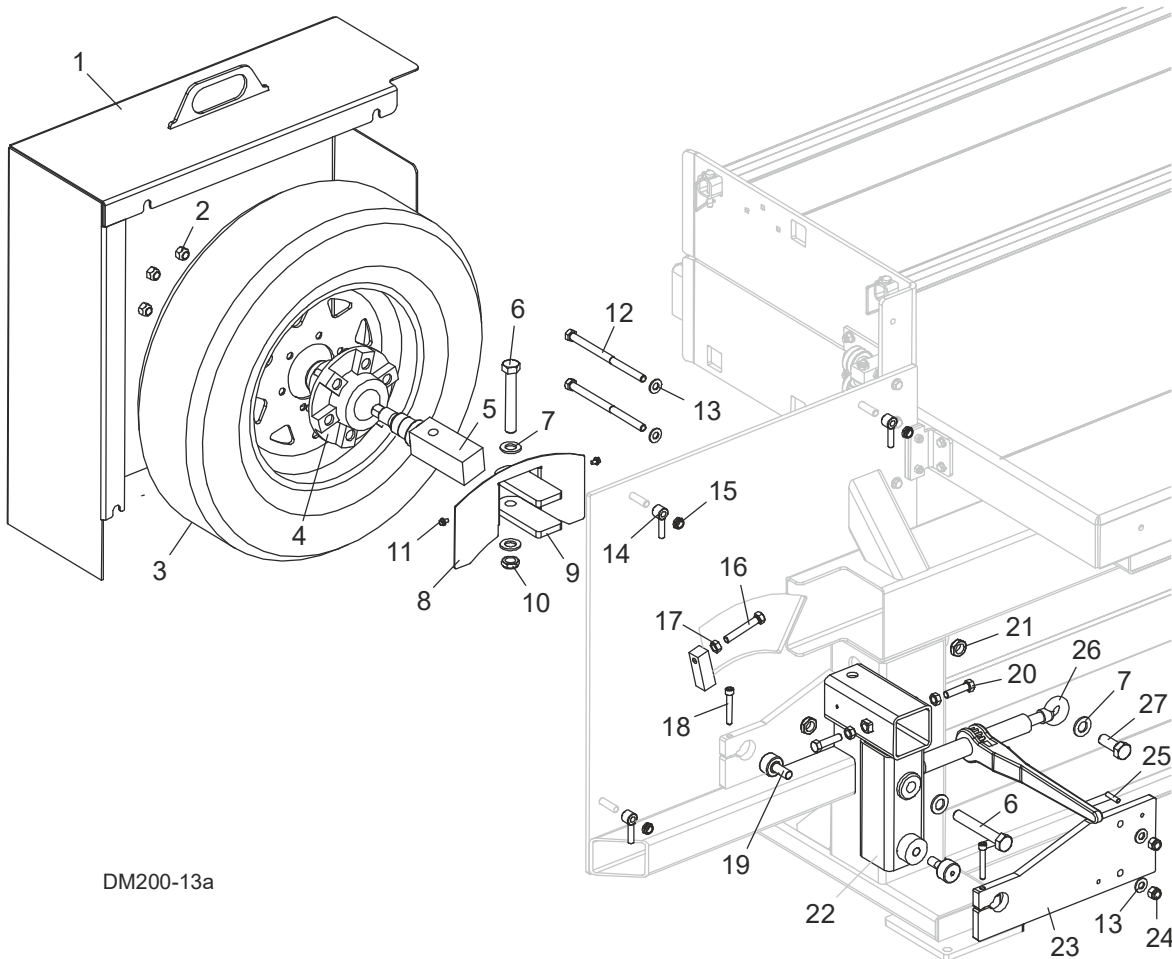

DM200-13a

REF	DESCRIPTION (♦ Indicates Parts Available in Assemblies Only)	PART #	QTY.
1	Cover Weldment, Dismantler Idle	079979	1
2	Nut, 1/2-20 Lug	P04646	6
3	Tire/Wheel Assembly, ST205/75D15	079939	1
	Shaft Assembly, Dismantler	079921	1
4	Hub, 6 lug Dismantler	079941	1
5	Shaft, Dismantler Idle Machined	079992	1
6	Bolt, 3/4-10x5 Hex Head Grade 5	F05009-88	2
7	Washer, 3/4 SAE Flat	F05011-62	4
8	Guard, Dismantler Idler	079983	1
9	Spacer, Dismantler Idler Side	079988	2
10	Nut, 3/4-10 Half Nyloc	F05010-122	1
11	Screw, 1/4-20x3/8 Hex Flanged Whiz Lock	F05005-78	2
12	Bolt, 1/2-13x8 Hex Head Grade 5	F05008-69	2

7

Parts*Pallet Dismantler Parts (Idle Side)*

REF	DESCRIPTION (♦ Indicates Parts Available in Assemblies Only)	PART #	QTY.
13	Washer, 1/2 SAE Flat	F05011-2	4
14	Nut Weldment, Cover	021145	3
15	Nut, 1/2-13 Half Nyloc	F05010-127	3
16	Bolt, 1/2-13x3 Full Thread Hex Head Tap	F05008-7	1
17	Nut, 1/2-13 Hex	F05010-35	3
18	Screw, 3/8-16x2 1/2 SHC	F05007-24	2
19	Bearing, Cam Follower 1 1/2	012797	2
20	Bolt, 1/2-13x2 Full Thread Grade 5	F05008-116	2
21	Nut, 3/4-10 Half Nyloc	F05010-122	2
22	Tensioner Weldment, Dismantler	079960	1
23	Plate, Tensioner Mount	079963	1
24	Nut, 1/2-13 Nyl Hex Lock	F05010-8	2
25	Pin, 5/16x1 1/4 Roll	F05012-127	2
26	Tensioner Ratchet, Dismantler	079975	1
27	Bolt, 3/4-10x2 Hex Head Grade 5	F05013-71	1

7.7 Pallet Dismantler Table Parts

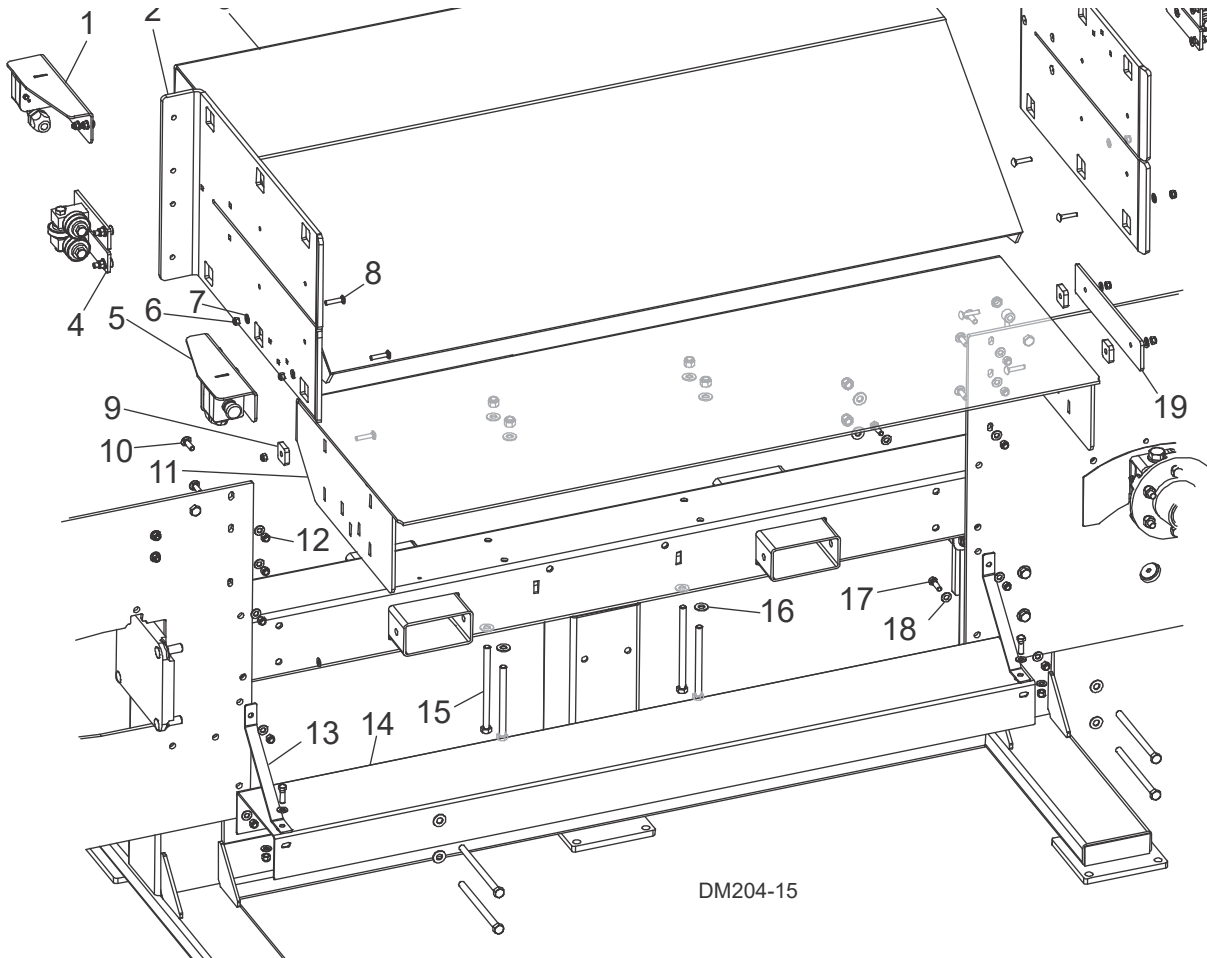

REF	DESCRIPTION (♦ Indicates Parts Available in Assemblies Only)	PART #	QTY.
1	Control Assy, Dismantler Rear, CD (See Section 7.8 Table Control Assembly)	079685	1
2	Plate, Dismantler Fence	079953	2
3	Table Wldmnt, Center Drop, Front	079652	1
	Table Wldmnt, Center Drop, Front, 72	079652-72	1
4	Blade Guide Assy, Dismantler (See Section 7.10 Blade Guide Assembly)	079957	2
5	Control Assy, Dismantler Front, CD (See Section 7.8 Table Control Assembly)	079681	1
6	Nut, 5/16-18 Nylok Hex	F05010-58	10
7	Washer, 5/16 SAE Flat	F05011-17	10
8	Bolt, 5/16-18x1-1/2 Carriage Gr5	F05006-153	10
9	Spacer, Dismantler Table	079659	4
10	Bolt, 3/8-16x1 1/4 Carriage Gr5	F05007-127	6
11	Table Wldmnt, Center Drop, Rear	079654	1
	Table Wldmnt, Center Drop, Rear 72	079654-72	1

7 Parts

Pallet Dismantler Table Parts

REF	DESCRIPTION (♦ Indicates Parts Available in Assemblies Only)	PART #	QTY.
12	Nut, 3/8-16 Hex Nyloc	F05010-10	20
13	Gusset, 7 3/4 x 7 3/4	079964	2
14	Frame Weldment, 60" Dismantler, CU	079998	1
	Frame Weldment, 72" Dismantler, CU	079998-72	1
15	Bolt, 1/2-13x7 1/2 HH FT	F05008-87	8
16	Washer, 1/2 SAE Flat	F05011-2	20
17	Bolt, 3/8-16x1 1/4 Full Thread Hex Head Grade 5	F05007-123	6
18	Washer, 3/8 Flat SAE	F05011-3	30
19	Plate, Table Mount	079660	1
Not Shown	Blades, Pallet Dismantler 268" Pack (3) (For Standard (60") units)	130824	1
	Blades, Pallet Dismantler 292" Pack (3) (For 72" units)	130826	1

7.8 Table Control Assembly

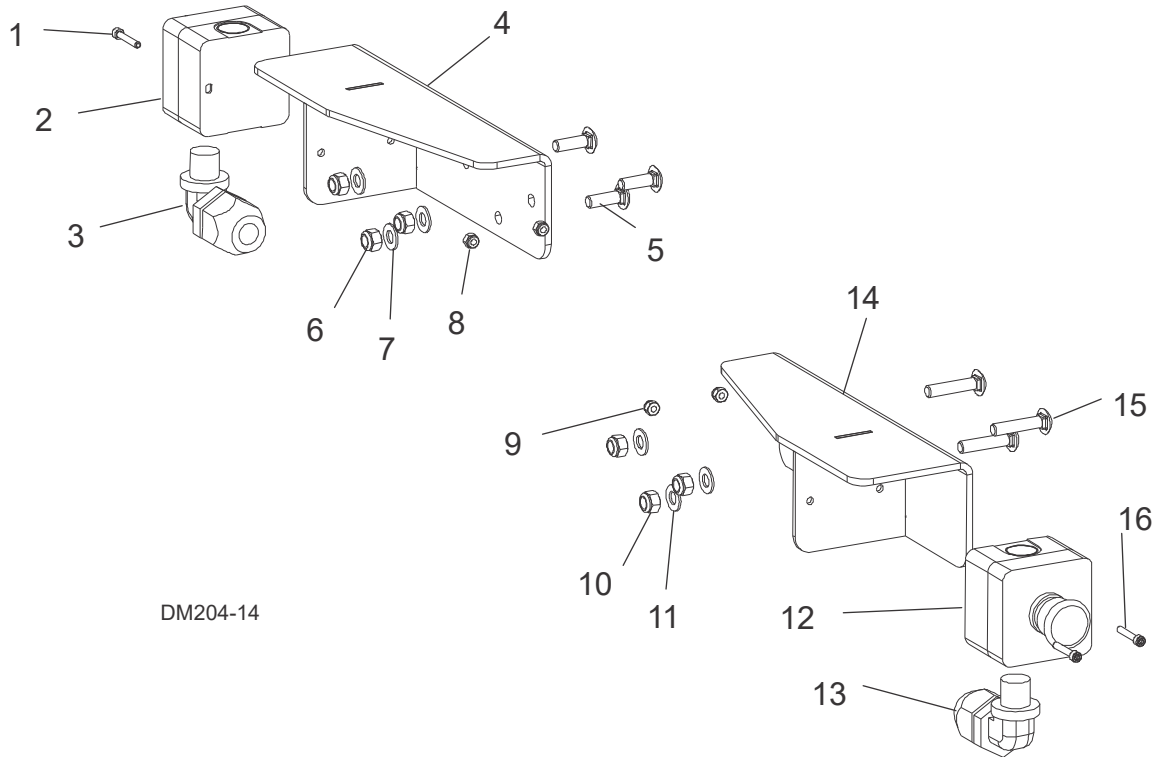

DM204-14

REF	DESCRIPTION (♦ Indicates Parts Available in Assemblies Only)	PART #	QTY.
	CONTROL ASSY, DISMANTLER REAR, CD	079685	
1	Screw, 8-32x1 SHC Brass	F05004-295	2
2	E-Stop Box, 40mm Oper-10A NC	052999	1
3	Connector, 1/2In 90 Deg Liquid Tight	E22722	1
4	Brkt Weldment, Rear Control, CD	079686	1
5	Bolt, 5/16-18x1 Carriage Gr5	f05006-90	3
6	Nut, 5/16-18 Nylok Hex	F05010-58	3
7	Washer, 5/16 SAE Flat	F05011-17	3
8	Nut, #8-32 Hex Nylock	F05010-169	2
	CONTROL ASSY, DISMANTLER FRONT, CD	079681	
9	Nut, #8-32 Hex Nylock	F05010-169	1
10	Nut, 5/16-18 Nylok Hex	F05010-58	1
11	Washer, 5/16 SAE Flat	F05011-17	1
12	E-Stop Box, 40mm Oper-10A NC	052999	2
13	Connector, 1/2In 90 Deg Liquid Tight	E22722	3
14	Brkt Weldment, Front Control, CD	079682	2
15	Bolt, 5/16-18x1-1/2 Carriage Gr5	F05006-153	3
16	Screw, 8-32x1 SHC Brass	F05004-295	3

7.9 Motor Control Assembly

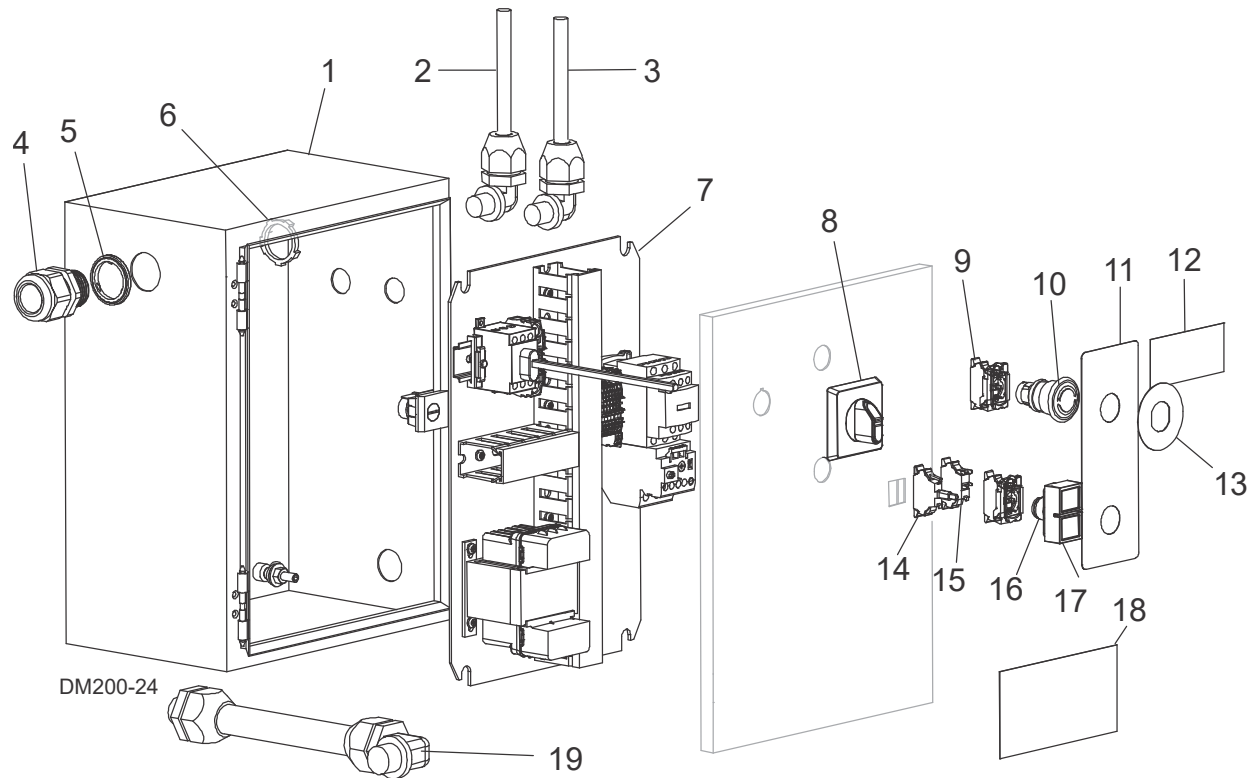

REF	DESCRIPTION (♦ Indicates Parts Available in Assemblies Only)	PART #	QTY.
	CONTROL ASSY, PD200A10 240VAC 1PH	114100	
	CONTROL ASSY, PD200B/C10 240/480VAC 3PH	114104	
	CONTROL ASSY, PD200K10 575VAC 3PH	114113	
1	Enclosure, Elec. Control PD200E	114115	1
2	Harness Assy, Rear E-Stop PD200E	114111	1
3	Harness Assy, Front E-Stop PD200E	114110	1
4	Connector, 1" NPT 0.59-1.00	069861	1
5	Ring, 1" Sealing	053734	1
6	Nut, 1" NPT Connector Lock Sealing	053735	1
7	Insert, Panel Assy PD200A10 240VAC 1PH (See Section) Insert, Panel Assy. PD200B/C10 240/480V 3PH (See Section) Insert, Panel Assy. PD200K10 575VAC 3PH (See Section)	114102 114105 114114	1
8	Handle, Disconnect RED/YEL 6mm Shaft	050883-1	1
9	Collar, Mount 1NC ZB5	068950	2
10	Push-Button, Mshrm Mntnd Red TrnRI ZB5	068940	1
11	Decal, PD200E Control	114112	1
12	Label, PD200A10 Elec Nameplate Label, PD200B/C10 Elec. Name Label, PD200K10 Elec. Name	114100-NPLBL 114104-NPLBL 114104-NPLBL	1

REF	DESCRIPTION (♦ Indicates Parts Available in Assemblies Only)	PART #	QTY.	
13	Legend, E-Stop, Round Yellow	050992	1	
14	Light Module, Green ZB5	068910	1	
15	Contact Block, NO ZB5	068920	1	
16	Push-Button, Grn/Red Flush Illuminated	068909	1	
17	Boot, Clear Sealing ZB Sw	052501	1	
18	Decal, Electrical Hazard Danger	S20061	1	
19	Harness Assy, PD200 240VAC 1PH Harness Assy, PD200 240/480 VAC 3PH Harness Assy, PD200 575VAC 3PH	114108 114109 114117	1	

7.10 Blade Guide Assembly

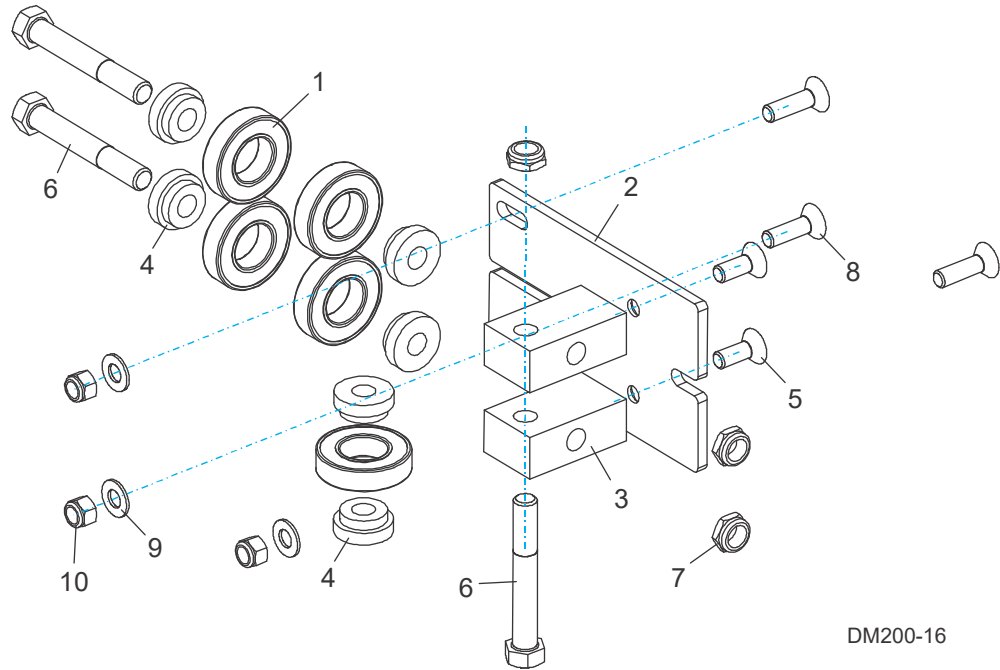

DM200-16

REF	DESCRIPTION (↗ Indicates Parts Available in Assemblies Only)	PART #	QTY.
	Blade Guide Assembly, Dismantler	079957	2
1	Bearing, R16 Sealed	042360	5
2	Mount, B/G Bearing	079954	1
3	Block, Dismantler Blade Guide	079955	2
4	Spacer, Dismantler Blade Guide	079956	6
5	Screw, 3/8-16x1 Zinc & Bake FSHC	F05007-64	2
6	Bolt, 1/2-13x3 1/2 HH Gr5	F05008-61	3
7	Nut, 1/2-13 Half Nyloc	F05010-127	3
8	Screw, 3/8-16 x 1-1/2 FHS SS	F05007-247	3
9	Washer, 3/8 Flat SAE	F05011-3	3
10	Nut, 3/8-16 Hex Nyloc	F05010-10	3

7.11 Decals

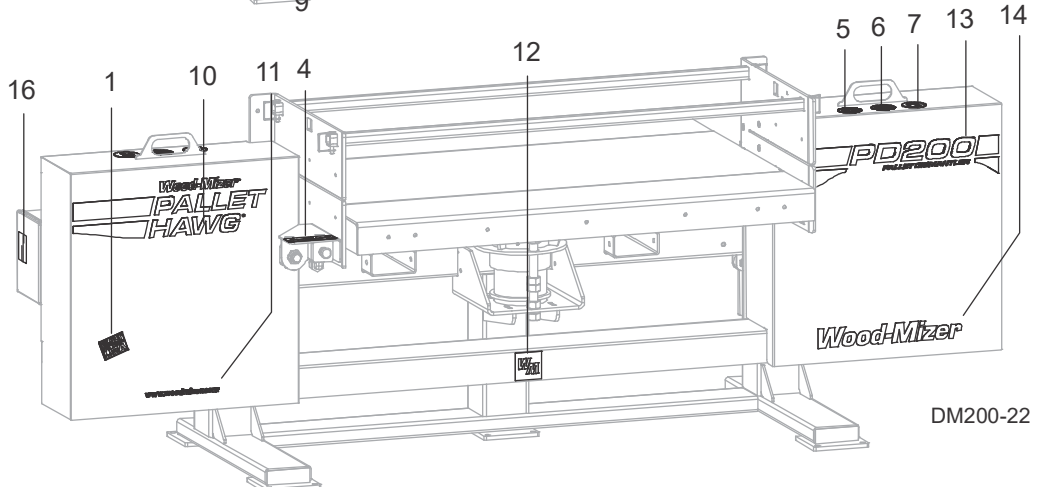
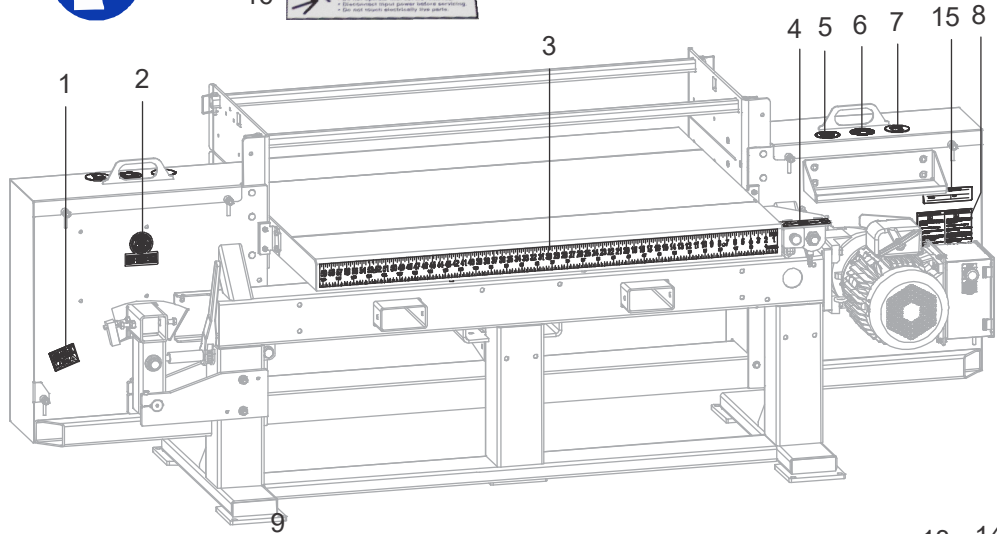
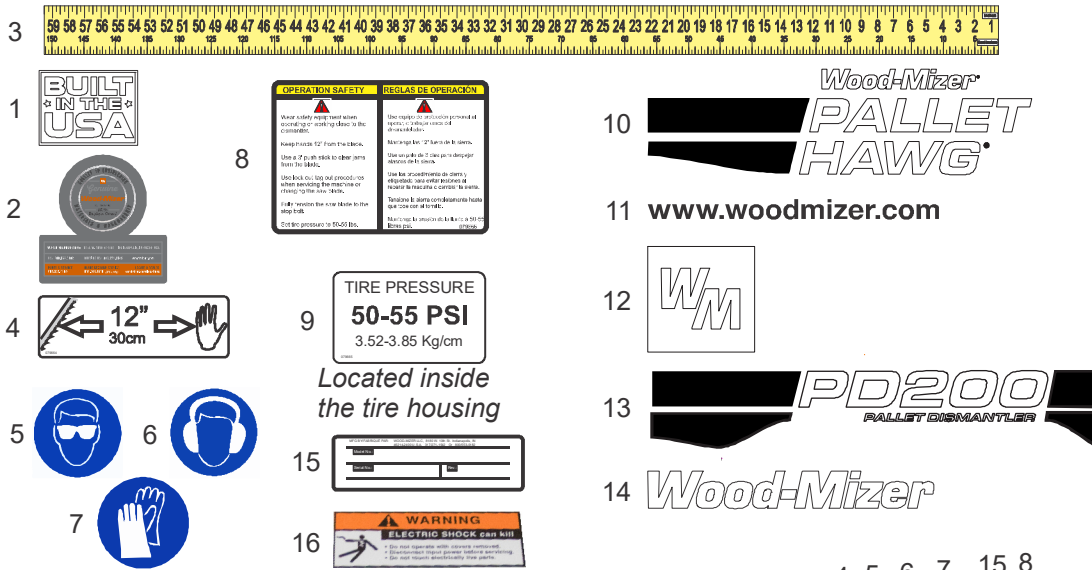

DM200-22

7 Parts

Decals

REF	DESCRIPTION (♦ Indicates Parts Available in Assemblies Only)	PART #	QTY.
	Decal Kit, Dismantler	079680	2
1	Decal, Built In The USA	074008	2
2	Decal, Wood-Mizer Quality & Information	079278	1
3	Decal, Pallet Scale	079667	1
4	Decal, Keep 12" Away	079664	2
5	Decal, Eye Warning	S12004G	2
6	Decal, Ear Warning	S12005G	2
7	Decal, Hand Protection	512107	2
8	Decal, Pallet Hawg Operation	079666	1
9	Decal, Pallet Hawg Tire Pressure	079665	2
10	Decal, Pallet Hawg	079661	1
11	Decal, Wood-Mizer Website	003235	1
12	Decal, WM Badge	079663	2
13	Decal, PD200	079662	1
14	Decal, Wood-Mizer Logo Wht LT40,50	065025	1
15	Decal, ID Serial No.	015820	1
16	Decal, Danger High Voltage	110781 ¹	1

¹ The original safety decal on the control box came from the vendor. If needing a replacement, order the 110781.